CLA-VAL

AUTOMATIC CONTROL VALVES

850-20

Place this manual with personnel responsible
for maintenance of this valve



Installation

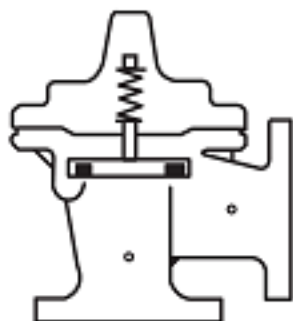

Operation

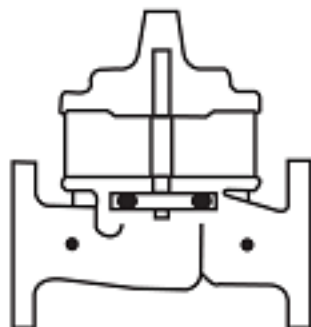

Maintenance



CLA-VAL CO. NEWPORT BEACH, CALIFORNIA

CATALOG NO.
850-20

DRAWING NO.
203182

REV.
B

TYPE OF VALVE AND MAIN FEATURES
**PRESSURE RELIEF VALVE
FOR FIRE PUMP SERVICE
(SEA WATER SERVICE)**

DESIGN		
DRAWN	AK	07-08-02
CHK'D	VL	7-10-02
APVD	CH	7-11-02

3-13-2003
09-05-13
PMC
RP
WAS X44. (ECO 19311)
B
ADDED CRL60 TO COMPONENT LIST (ECO 23596)

CAD REVISION RECORD - DO NOT REVISE MANUALLY
DESCRIPTION
BY DATE
A.K. 07-08-02
- RELEASED FOR PRODUCTION (NED 47184)
A DEL 81-01 CHECK VALVE: ADDED ITEM H: ITEM 3

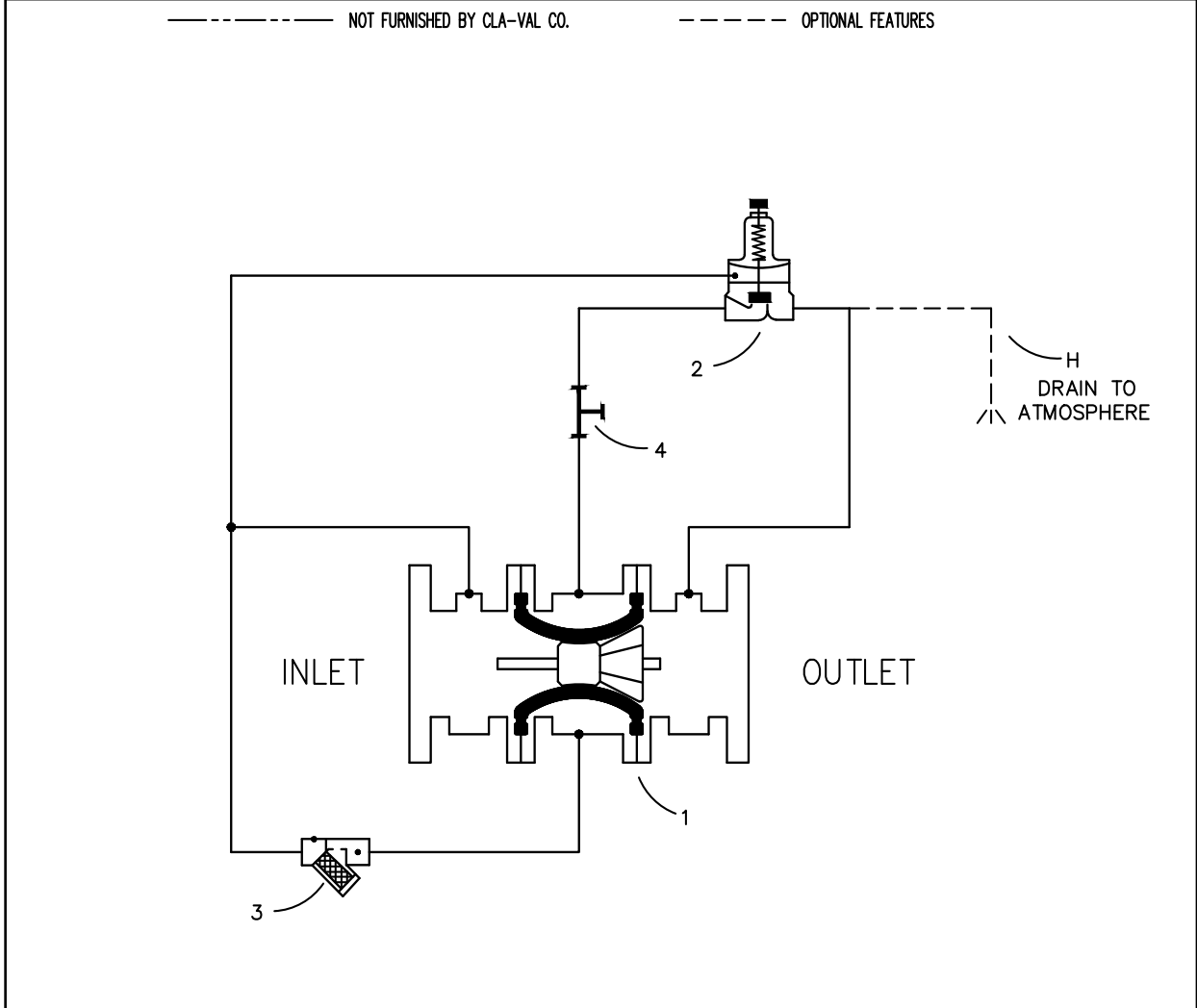

ITEM NO.	BASIC COMPONENTS	QTY
1	100-43 TDV MAIN VALVE	1
2	CRL/CRL60 PRESSURE RELIEF CONTROL	1
3	X44A STRAINER AND ORIFICE ASSEMBLY	1
4	GAGE CONNECTION	1

OPTIONAL FEATURE SUFFIX		ADDED TO CATALOG NUMBER	
H	DRAIN TO ATMOSPHERE		

THIS DRAWING IS THE PROPERTY OF CLA-VAL CO. AND SAME AND COPIES MADE THEREOF, IF ANY, SHALL BE RETURNED TO IT UPON DEMAND. DELIVERY AND DISCLOSURE HEREOF ARE SOLELY UPON CONDITION THAT THE SAME SHALL NOT BE USED, COPIED OR REPRODUCED, NOR SHALL THE SUBJECT HEREOF BE DISCLOSED IN ANY MANNER TO ANYONE FOR ANY PURPOSE, EXCEPT AS HEREIN AUTHORIZED, WITHOUT PRIOR WRITTEN APPROVAL OF CLA-VAL CO. THIS DRAWING IS SUBMITTED CONFIDENTIALLY AND MAY NOT BE USED IN THE MANUFACTURE OF ANY MATERIAL OR PRODUCT OTHER THAN SUCH MATERIALS AND PRODUCTS FURNISHED TO CLA-VAL CO. WHETHER OR NOT THE EQUIPMENT OR INFORMATION SHOWN HEREON IS PATENTED OR OTHERWISE PROTECTED, FULL TITLE AND COPYRIGHTS, IF ANY, IN AND TO THIS DRAWING AND/OR INFORMATION DELIVERED OR SUBMITTED ARE FULLY RESERVED BY CLA-VAL CO.

 CLA-VAL CO. NEWPORT BEACH, CALIFORNIA	CATALOG NO. 850-20	DRAWING NO. 203182	REV. B
	TYPE OF VALVE AND MAIN FEATURES PRESSURE RELIEF VALVE FOR FIRE PUMP SERVICE (SEA WATER SERVICE)		DESIGN DRAWN AK 07-08-02 CHK'D VL 7-10-02 APVD CH 7-11-02

OPERATING DATA

I. PRESSURE RELIEF FEATURE:

PRESSURE RELIEF CONTROL (2) IS A NORMALLY CLOSED CONTROL THAT RESPONDS TO MAIN VALVE INLET PRESSURE CHANGES. AN INCREASE IN INLET PRESSURE TENDS TO OPEN CONTROL (2) AND A DECREASE IN INLET PRESSURE TENDS TO CLOSE CONTROL (2), THIS CAUSES LOADING CHAMBER PRESSURE TO VARY AND THE MAIN VALVE MODULATES (OPENS AND CLOSES) MAINTAINING A RELATIVELY CONSTANT PRESSURE AT THE MAIN VALVE INLET. WHEN INLET PRESSURE IS LOWER THAN THE SET POINT OF CONTROL (2), CONTROL (2) CLOSES. THIS PRESSURIZES THE LOADING CHAMBER AND THE MAIN VALVE CLOSES. PRESSURE RELIEF CONTROL (2) ADJUSTMENT: TURN THE ADJUSTING SCREW CLOCKWISE TO INCREASE THE SETTING.

II. OPTIONAL FEATURE OPERATING DATA:

SUFFIX H (ATMOSPHERIC DRAIN)

PILOT SYSTEM DRAIN LINE IS DISCHARGED TO ATMOSPHERE. [PILOT SYSTEM DRAIN LINE IS CONNECTED TO THE MAIN VALVE OUTLET BOSS IF SUFFIX (H) IS NOT SPECIFIED]

III. CHECK LIST FOR PROPER OPERATION:

- () SYSTEM VALVES OPEN UPSTREAM AND DOWNSTREAM.
- () AIR REMOVED FROM MAIN VALVE LOADING CHAMBER AND PILOT SYSTEM AT ALL HIGH POINTS.
- () PERIODIC CLEANING OF STRAINER (3) IS RECOMMENDED.

CAD REVISION RECORD - DO NOT REVISE MANUALLY DESCRIPTION SEE SHEET 1	BY	DATE
LTR		



MODEL — **100-43**

800 Series

Tubular Diaphragm Valve



- Low Head Loss
- Cast Steel Construction
- Fusion Coated Epoxy Inside and Out
- Anti-Cavitation Design
- Nickel Aluminum Bronze Construction Option (Alloy C95800)
- Duplex Stainless Steel Construction Option (Alloy 2205)
- Low Maintenance
- Simple and Reliable Operation
- 1-Year Warranty

The Cla-Val Model 100-43 Tubular Diaphragm Valve is a pressure-operated, in-line axial valve. A tube diaphragm actuates the valve, which is comprised of three major components: 1) Tube 2) Barrier and 3) Body. There is only one moving part in the valve — the tube diaphragm. There are no shafts, packing, stem guides or springs.

The tube diaphragm is a one piece, homogeneous nitrile rubber part which is extremely durable. The ends of the tube are thick solid rubber, designed to fit between mating flanges. This design eliminates the possibility of cutting the tube diaphragm due to over tightening or piping misalignment during installation.

The tube forms a drip tight seal around the barrier when the pressure is equalized between the valve inlet and the control chamber. When pressure is removed from the control chamber, the valve is open. The minimum recommended operating pressure is 40 P.S.I. of inlet pressure.

Principle of Operation

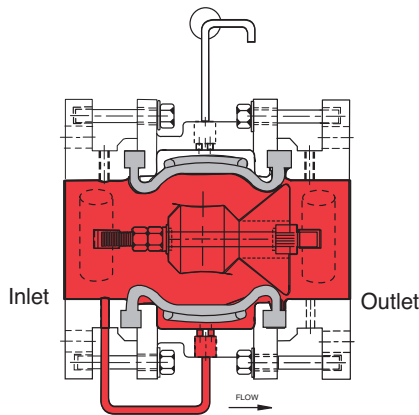

Full Open Operation

The valve opens when pilot set pressure is reached and pressure in the control chamber is relieved.

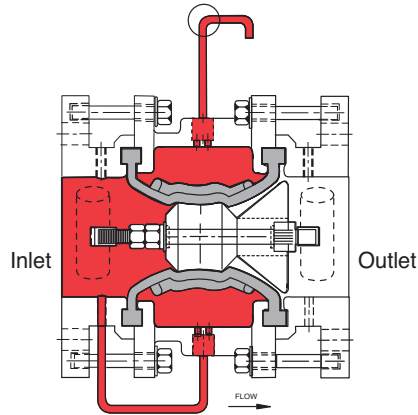

Tight Closing Operation

Water pressure (equal to inlet pressure) from valve inlet or from upstream of valve is applied to the control chamber. Valve closes bubble tight.

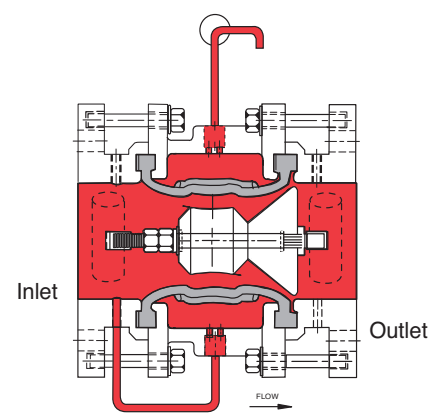

Modulating Action

The valve tube diaphragm holds any intermediate position when a quantity of water is exhausted from the control chamber via the pilot. The quantity of water in the control chamber is established by the "set pressure" of the pilot.

The control chamber is filled or exhausted to atmosphere, maintaining "set pressure."

MAIN VALVE

Ends: Flanged ANSI B16.5 (150lb Class)
 Body: Cast Steel (ASTM A216 WCB)
 Tube Diaphragm: Nitrile Rubber
 Barrier: Urethane
 Bolts: 316 SS
 Pressure: 250 psig (17.24 BAR)
 Temp. Range: 32° F to 180° F
 (0° C to 82.2° C)

Model 100-43



MAIN VALVE OPTIONS

Body: Nickel Aluminum Bronze
 (Alloy C95800) or
 Duplex SS (Alloy 2205)

Note: For valve pilot assembly, only use the X43 "Y" Strainer,
 NOT the X46A Flow Clean Strainer

Dimensions

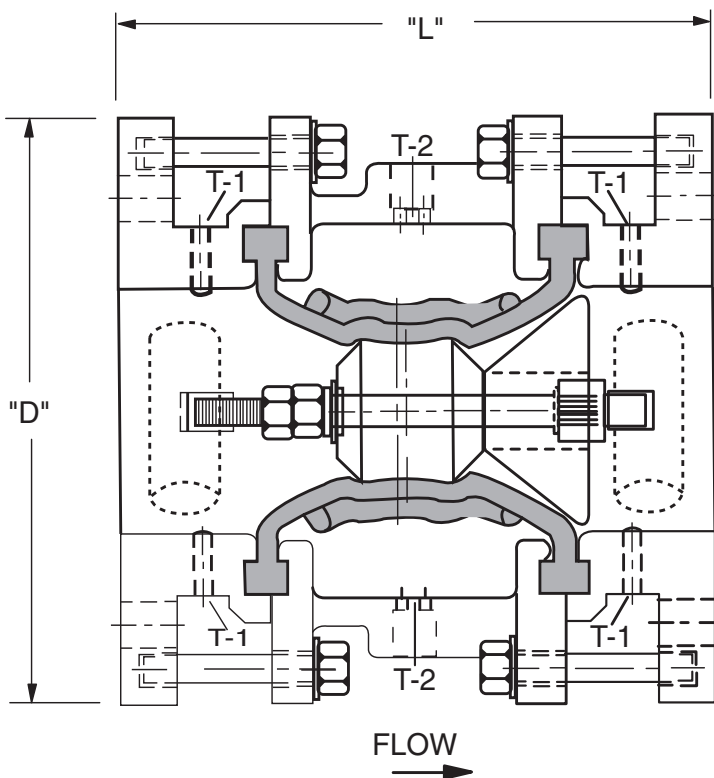

Valve Size (Inches)	3	4	6	8	10
L	8.75	9.75	10.75	11.75	14.00
D	7.5	9.50	11.75	14.00	16.44
T-1 (NPT)	0.25	0.25	0.25	0.38	0.50
T-2 (NPT)	0.25	0.50	0.50	0.50	0.50
Approx. Wt. (Lbs.)	67	99	135	185	270

Valve Size (mm)	80	100	150	200	250
L	222	248	273	299	299
D	191	241	299	356	356
T-1 (NPT)	0.25	0.25	0.25	0.38	0.50
T-2 (NPT)	0.25	0.50	0.50	0.50	0.50
Approx. Wt. (Kgs.)	30	45	61	84	123

4", 6", 8" / 100, 150 and 200 mm
 Factory Mutual Approved
 (with approved Pilot Components)

Flow Factors		
Size (inches/mm)	Cv (gpm)	KV
3"/80 mm	160	36.4
4"/100 mm	340	77.3
6"/150 mm	885	201
8"/200 mm	1667	379
*10"/250 mm	2424	550

* Calculated

When Ordering Please Specify:

1. Catalog No. 100-43
2. Valve Size
3. Fluid Being Handled
4. Fluid Temperature Range
5. Inlet Pressure Range
6. Outlet Pressure Range
7. Maximum Differential Pressure
8. Minimum Differential Pressure
9. Maximum Flow Rate



E-100-43 (R-12/2017)

CLA-VAL

1701 Placentia Avenue • Costa Mesa CA 92627
 800-942-6326 • Fax: 949-548-5441 • Web Site: cla-val.com • E-mail: info@cla-val.com

CLA-VAL CANADA

4687 Christie Drive
 Beamsville, Ontario
 Canada L0R 1B4
 Phone: 905-563-4963
 Fax: 905-563-4040
 E-mail sales@cla-val.ca

CLA-VAL EUROPE

Chemin des Mésanges 1
 CH-1032 Romanef/
 Lausanne, Switzerland
 Phone: 41-21-643-15-55
 Fax: 41-21-643-15-50
 E-mail: cla-val@cla-val.ch

CLA-VAL UK

Dainton House, Goods Station Road
 Tunbridge Wells
 Kent TN1 2 DH England
 Phone: 44-1892-514-400
 Fax: 44-1892-543-423
 E-mail: info@cla-val.co.uk

CLA-VAL FRANCE

Porte du Grand Lyon 1
 ZAC du Champ du Périer
 France - 01700 Neyron
 Phone: 33-4-72-25-92-93
 Fax: 33-4-72-25-04-17
 E-mail: cla-val@cla-val.fr

CLA-VAL PACIFIC

45 Kennaway Road
 Woolston, Christchurch, 8023
 New Zealand
 Phone: 64-39644860
 www.cla-valpacific.com
 E-mail: info@cla-valpacific.com



Pressure Relief Control

DESCRIPTION

The CRL Pressure Relief Control is a direct acting, spring loaded, diaphragm type relief valve. It may be used as a self-contained valve or as a pilot control for a Cla-Val Main valve. It opens and closes within very close pressure limits.

INSTALLATION

The CRL Pressure Relief Control may be installed in any position. The control body (7) has one inlet and one outlet port with a side pipe plug (24) at each port. These plugs are used for control connections or gauge applications. The inlet in the power unit body (6) is the sensing line port. A flow arrow is marked on the body casting.

OPERATION

The CRL Pressure Relief Control is normally held closed by the force of the compression spring above the diaphragm; control pressure is applied under the diaphragm.

When the controlling pressure exceeds the spring setting, the disc is lifted off its seat, permitting flow through the control.

When controlling pressure drops below spring setting, the spring returns the control to its normally closed position.

ADJUSTMENT PROCEDURE

The CRL Pressure Relief Control can be adjusted to provide a relief setting at any point within the range found on the nameplate.

Pressure adjustment is made by turning the adjustment screw (9) to vary the spring pressure on the diaphragm. Turning the adjustment screw clockwise increases the pressure required to open the valve. Counterclockwise decreases the pressure required to open the valve.

When pressure adjustments are complete the jam nut (10) should be tightened and the protective cap (1) replaced. If there is a problem of tampering, lock wire holes have been provided in cap and cover. Wire the cap to cover and secure with lead seal.

DISASSEMBLY

The CRL Pressure Relief Control does not need to be removed from the line for disassembly. Make sure that pressure shut down is accompanied prior to disassembly. If the CRL is removed from the line for disassembly be sure to use a soft jawed vise to hold body during work.

Refer to Parts List Drawing for Item Numbers.

1. Remove cap (1), loosen jam nut (10) and turn adjusting screw counterclockwise until spring tension is relieved.
2. Remove the eight screws (4) holding the cover (3) and powerunit body (6). Hold the cover and powerunit together and place on a suitable work surface.
See NOTE under REASSEMBLY.
3. Remove the cover (3) from powerunit body (6). The spring (12) and two spring guides (11).
4. Remove nut (13) from stem (19) and slide off the belleville washer (14), the upper diaphragm washer (15) and the diaphragm (16).
5. Pull the stem (19) with the disc retainer assembly (21) through the bottom of powerunit. The lower diaphragm washer (17) will slide off of stem top.
6. Remove jam nut (23) and disc retainer assembly (21) from stem. Use soft jawed pliers or vise to hold stem. The polished surface of stem must not be scored or scratched.
7. The seat (22) need not be removed unless it is damaged. If removal is necessary use proper size socket wrench and turn counterclockwise.

Note: Some models have an integral seat in the body (7).

INSPECTION

Inspect all parts for damage, or evidence of cross threading. Check diaphragm and disc retainer assembly for tears, abrasions or other damage. Check all metal parts for damage, corrosion or excessive wear.

REPAIR AND REPLACEMENT

Minor nicks and scratches may be polished out using 400 grit wet or dry sandpaper fine emery or crocus cloth. Replace all O-rings and any damaged parts.

When ordering replacement parts, be sure to specify parts list item number and all nameplate data.

REASSEMBLY

In general, reassembly is the reverse of disassembly. However, the following steps should be observed:

1. Lubricate the O-Ring (18) with a small amount of a good grade of waterproof grease, (Dow Corning 44 medium grade or equal). Use grease sparingly and install O-ring in powerunit body (6).
2. Install stem (19) in powerunit body (6). Use a rotating motion with minimum pressure to let stem pass through O-ring.
Do Not Cut O-Ring.
3. Install O-ring (5) at top of stem (19). Place lower diaphragm washer (17) on the stem with the serrated side up. Position diaphragm (16), upper diaphragm washer (15), with serration down, and belleville washer (14) with concave side down.
4. Position powerunit body (6) as shown on parts list drawing (top view).
5. Continue reassembly as outlined in disassembly steps 1 through 3.

Note: Item (4) Screw will have a quantity of 8 for the 0-75 and 20-200psi design and a quantity of 4 for the 100-300psi design. Item (25) Screw is used on the 100-300psi design only. Install item (25), before item (4) for preload of item (12) spring.

SYMPTOM	PROBABLE CAUSE	REMEDY
Fails to open.	Controlling pressure too low.	Back off adjusting screw until valve opens.
Fails to open with spring compression removed.	Mechanical obstruction, corrosion, scale build-up on stem.	Disassemble, locate, and remove obstruction, scale.
Leakage from cover vent hole when controlling pressure is applied.	Diaphragm Damage	Disassembly replace damaged diaphragm.
	Loose diaphragm assembly.	Tighten upper diaphragm washer.
Fails to close.	No spring compression.	Re-set pressure adjustment.
Fails to close with spring compressed.	Mechanical obstruction.	Disassemble, locate and remove obstruction.



1/2" & 3/4" PRESSURE RELIEF CONTROL

(Bronze Body with 303SS Trim)

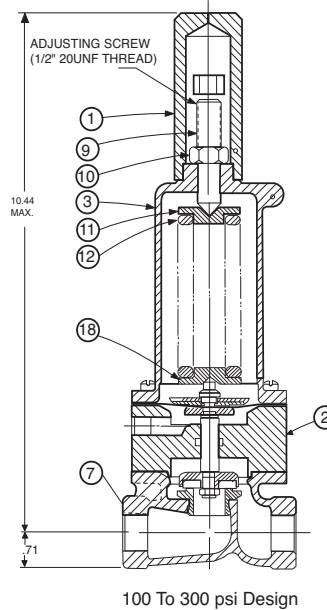
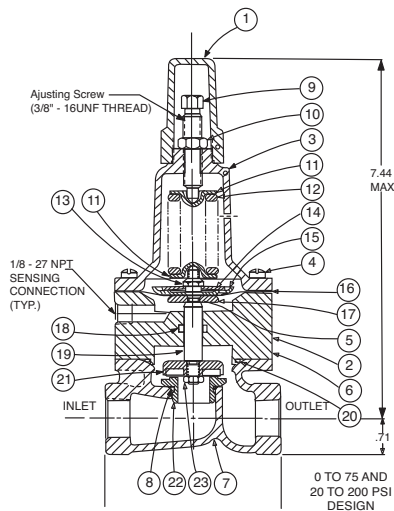
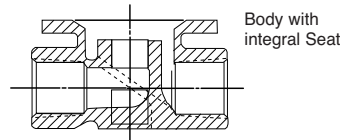
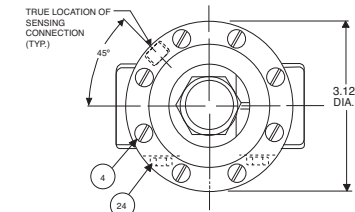

SIZE	SPRING	PART NUMBER
1/2"	0-75 PSI	7922201E
1/2"	20-105 PSI	7922205F
1/2"	20-200 PSI	7922202C
1/2"	100-300 PSI	8280901D
3/4"	0-75 PSI	7922901K
3/4"	20-105 PSI	7922903F
3/4"	20-200 PSI	7922902H
3/4"	100-300 PSI	8600501E

For 250-600 PSI Contact Factory

CRL Range PSI	APPROX. INCREASE FOR EACH CLOCKWISE TURN OF ADJUSTING SCREW
0 to 75	8.5 PSI
20 to 105	12.5 PSI
20 to 200	28.0 PSI
100 to 300	18.0 PSI

When ordering parts please specify:

1. All Nameplate Data
2. Item Part Number
3. Item Description

Item	Description	Material	Part Number			
			0-75	20-105	20-200	100-300
1	Cap	Plastic	67628J	67628J	67628J	1257601D
2	Nameplate	Brass	--	--	--	--
3	Cover	Bronze	C2544K	C2544K	C2544K	44587E
4*	Screw Fil. Hd. 10-32 x 1.88 (Qty 8)	303 SS	6757867E	6757867E	6757867E	6757867E
5*	O-Ring	Rubber	00902H	00902H	00902H	00902H
6	Body, Powerunit	Bronze	7920504D	7920504D	7920504D	7920504D
7	1/2" Body	Bronze	C7928K	C7928K	C7928K	C7928K
	3/4" Body	Bronze	C9083B	C9083B	C9083B	C9083B
8*	O-Ring, Seat	Rubber	00718H	00718H	00718H	00718H
9	Screw, Adjusting	Brass	7188201D	7188201D	7188201D	82811B
10	Nut Hex (Locking)	303 SS	6780106J	6780106J	6780106J	6780606H
11	Guide, Spring	303 SS	71881H	71881H	71881H	1630301J
12	Spring	CHR/VAN	71884B	20632101E	71885J	1630201A
13	Nut, Stem Upper	Bronze	73034B	73034B	73034B	73034B
14	Washer, Belleville	Steel	7055007E	7055007E	7055007E	7055007E
15	Washer, Diaphragm (upper)	303 SS	71891G	71891G	71891G	71891G
16*	Diaphragm	Rubber	C1505B	C1505B	C1505B	C1505B
17	Washer, Diaphragm (lower)	303 SS	45871B	45871B	45871B	45871B
18*	O-Ring, Stem	Rubber	00746J	00746J	00746J	00746J
19	Stem	303 SS	8982401F	8982401F	8982401F	8982401F
20*	O-Ring, Body	Rubber	00767E	00767E	00767E	00767E
21*	Retainer Assembly, Disc	303 SS	C9158B	C9158B	C9158B	C9158B
22	Seat	303Rub	62187A	62187A	62187A	62187A
23	Nut, Hex, Stem, Lower	Bronze	6779806G	6779806G	6779806G	6779806G
24	Pipe Plug	Bronze	6784701C	6784701C	6784701C	6784701C
	FACTORY SET POINT		50 PSI	60 PSI	60 PSI	100 PSI
	REPAIR KIT*		9170007A	9170007A	9170007A	9170007A



X44A

Strainer and Orifice Assembly

BRONZE BODY — DELRIN ORIFICE

3/8" x 3/8"

X44A STOCK NO.	ORIFICE DIA.	ORIFICE PLUG PART # (ITEM 5)
71310-01F	.031	94132-01
-02	.046	-02E
-03B	.062	-03C
-04K	.078	-04A
-05G	.093	-05H
-06	.109	-06
*-07C	.125	-07D
-08	.140	-08
-09	.156	-09
-10	.187	-10H
-11	.172	-11F

*Standard

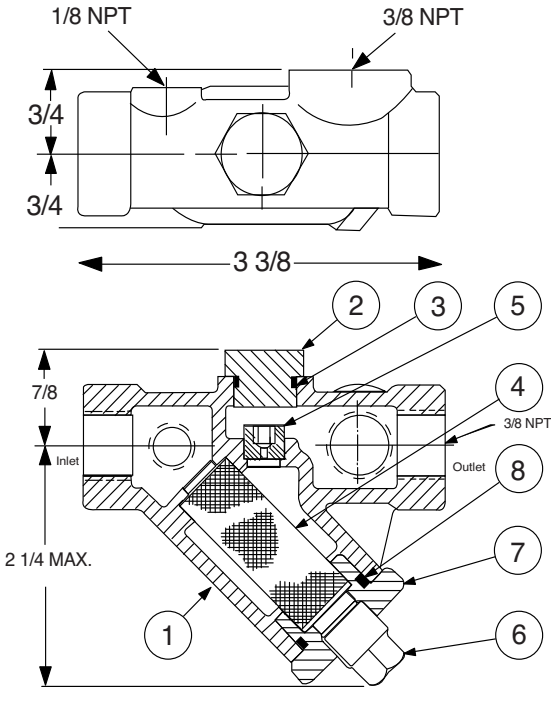

When ordering parts, please specify:

- All Nameplate Data
- Item Number
- Description
- Recommended Spare Parts

ITEM	DESCRIPTION	MATERIAL	QTY.
1	Body	Red Brs.	1
2	Plug, Top	Brass	1
3	"O" Ring, Plug Top	Syn. Rub.	1
4	Screen	Monel	1
5	Orifice Plug	Delrin	1
6	Plug, Pipe	Brass	1
7	Strainer Plug	S.S.	1
8	"O" Ring, Strainer Plug	Syn. Rub.	1

Proper Identification

For ordering repair kits, replacement parts, or for inquiries concerning valve operation, it is important to properly identify Cla-Val products already in service by including all nameplate data with your inquiry. Pertinent product data includes valve function, size, material, pressure rating, end details, type of pilot controls used and control adjustment ranges.

Identification Plates

For product identification, cast-in body markings are supplemented by identification plates as illustrated on this page. The plates, depending on type and size of product, are mounted in the most practical position. **It is extremely important that these identification plates are not painted over, removed, or in any other way rendered illegible.**

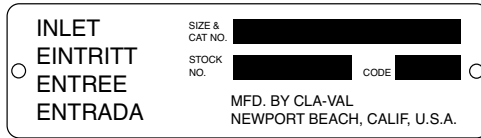

This brass plate appears on valves sized 2 1/2" and is located on the top of the inlet flange.

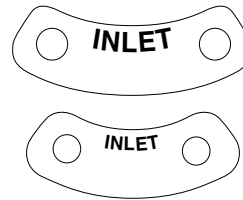

These two brass plates appear on 3/8", 1/2", and 3/4" size valves and are located on the valve cover.



This brass plate appears on altitude valves only and is found on top of the outlet flange.

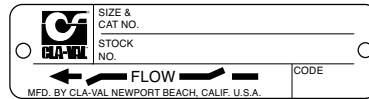

These two brass plates appear on threaded valves 1" through 3" size or flanged valves 1" through 2". It is located on only one side of the valve body.

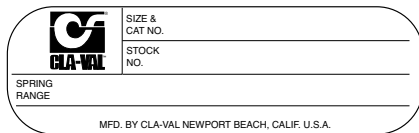

This tag is affixed to the cover of the pilot control valve. The adjustment range appears in the spring range section.

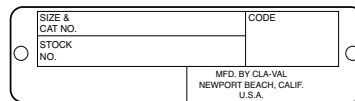

This brass plate is used to identify pilot control valves. The adjustment range is stamped into the plate.

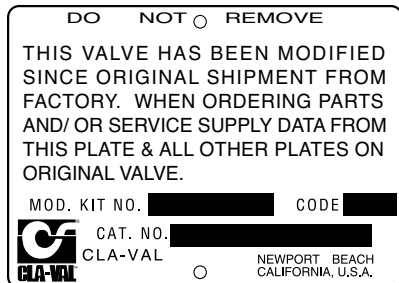

This aluminum plate is included in pilot system modification kits and is to be wired to the new pilot control system after installation.

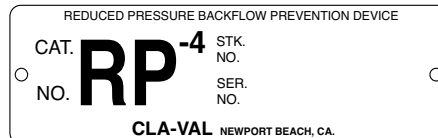

This brass plate is used on our backflow prevention assemblies. It is located on the side of the Number Two check (2" through 10"). The serial number of the assembly is also stamped on the top of the inlet flange of the Number One check.

HOW TO ORDER

Because of the vast number of possible configurations and combinations available, many valves and controls are not shown in published product and price lists. For ordering information, price and availability on product that are not listed, please contact your local Cla-Val office or our factory office located at:

P. O. Box 1325
Newport Beach, California 92659-0325
(949) 722-4800
FAX (949) 548-5441

SPECIFY WHEN ORDERING

- Model Number
- Globe or Angle Pattern
- Adjustment Range (As Applicable)
- Valve Size
- Threaded or Flanged
- Body and Trim Materials
- Optional Features
- Pressure Class

UNLESS OTHERWISE SPECIFIED

- Globe or angle pattern are the same price
- Ductile iron body and bronze trim are standard
- X46 Flow Clean Strainer or X43 "Y" Strainer are included
- CK2 Isolation Valves are included in price on 4" and larger valve sizes (6" and larger on 600 Series)

LIMITED WARRANTY

Automatic valves and controls as manufactured by Cla-Val are warranted for three years from date of shipment against manufacturing defects in material and workmanship that develop in the service for which they are designed, provided the products are installed and used in accordance with all applicable instructions and limitations issued by Cla-Val. Electronic components manufactured by Cla-Val are warranted for one year from the date of shipment.

We will repair or replace defective material, free of charge, that is returned to our factory, transportation charges prepaid, if upon inspection, the material is found to have been defective at time of original shipment. This warranty is expressly conditioned on the purchaser's providing written notification to Cla-Val immediate upon discovery of the defect.

Components used by Cla-Val but manufactured by others, are warranted only to the extent of that manufacturer's guarantee.

This warranty shall not apply if the product has been altered or repaired by others, Cla-Val shall make no allowance or credit for such repairs or alterations unless authorized in writing by Cla-Val.

DISCLAIMER OF WARRANTIES AND LIMITATIONS OF LIABILITY

The foregoing warranty is exclusive and in lieu of all other warranties and representations, whether expressed, implied, oral or written, including but not limited to any implied warranties or merchantability or fitness for a particular purpose. All such other warranties and representations are hereby cancelled.

Cla-Val shall not be liable for any incidental or consequential loss, damage or expense arising directly or indirectly from the use of the product. Cla-Val shall not be liable for any damages or charges for labor or expense in making repairs or adjustments to the product. Cla-Val shall not be liable for any damages or charges sustained in the adaptation or use of its engineering data and services. No representative of Cla-Val may change any of the foregoing or assume any additional liability or responsibility in connection with the product. The liability of Cla-Val is limited to material replacements F.O.B. Newport Beach, California.

TERMS OF SALE

ACCEPTANCE OF ORDERS

All orders are subject to acceptance by our main office at Newport Beach, California.

CREDIT TERMS

Credit terms are net thirty (30) days from date of invoice.

PURCHASE ORDER FORMS

Orders submitted on customer's own purchase order forms will be accepted only with the express understanding that no statements, clauses, or conditions contained in said order form will be binding on the Seller if they in any way modify the Seller's own terms and conditions of sales.

PRODUCT CHANGES

The right is reserved to make changes in pattern, design or materials when deemed necessary, without prior notice.

PRICES

All prices are F.O.B. Newport Beach, California unless expressly stated otherwise on our acknowledgement of the order. Prices are subject to change without notice. The prices at which any order is accepted are subject to adjustment to the Seller's price in effect at the time of shipment. Prices do not include sales, excise, municipal, state or any other Government taxes. Minimum order charge \$100.00.

RESPONSIBILITY

We will not be responsible for delays resulting from strikes, accidents, negligence of carriers, or other causes beyond our control. Also, we will not be liable for any unauthorized product alterations or charges accruing there from.

RISK

All goods are shipped at the risk of the purchaser after they have been delivered by to the carrier. Claims for error, shortages, etc., must be made upon receipt of goods.

EXPORT SHIPMENTS

Export shipments are subject to an additional charge for export packing.

RETURNED GOODS

1. Customers must obtain written approval from Cla-Val prior to returning any material.
2. Cla-Val reserves the right to refuse the return of any products.
3. Products more than six (6) months old cannot be returned for credit.
4. Specially produced, non-standard models cannot be returned for credit.
5. Rubber goods such as diaphragms, discs, o-rings, etc., cannot be returned for credit, unless as part of an unopened vacuum sealed repair kit which is less than six months old.
6. Goods authorized for return are subject to a 35% (\$100 minimum) restocking charge and a service charge for inspection, reconditioning, replacement of rubber parts, retesting, repainting and repackaging as required.
7. Authorized returned goods must be packaged and shipped prepaid to Cla-Val, 1701 Placentia Avenue, Costa Mesa, California 92627.



E-Product I.D. (R-3/2011)

CLA-VAL

PO Box 1325 Newport Beach CA 92659-0325
Phone: 949-722-4800 • Fax: 949-548-5441

CLA-VAL CANADA

4687 Christie Drive
Beamsville, Ontario
Canada L0R 1B4
Phone: 905-563-4963
Fax: 905-563-4040

CLA-VAL EUROPE

Chemin des Mesanges 1
CH-1032 Romanel/
Lausanne, Switzerland
Phone: 41-21-643-15-55
Fax: 41-21-643-15-50

©COPYRIGHT CLA-VAL 2011 Printed in USA
Specifications subject to change without notice.

www.cla-val.com

Represented By:



—MODEL— **REPAIR KITS**

Model 100-01 Hytrol Main Valve

BUNA-N MATERIAL				
	RUBBER KIT	REPAIR KIT	REBUILD KIT	STUD & NUT KIT
	STOCK NO.	STOCK NO.	STOCK NO.	STOCK NO.
3/8"	9169801K		21176614B	21176633J
1/2"	9169802H	21176602F	21176615A	21176634H
3/4"	9169802H	21176602F	21176615A	21176634H
1" Non-Guided	9169803F	21176601G	21176616K	21176636F
1"	9169804D	21176603E	21176617J	21176636F
1 1/4"	9169804D	21176603E	21176617J	21176636F
1 1/2"	9169804D	21176603E	21176617J	21176636F
2"	9169805A	21176608K	21176618H	21176637E
2 1/2"	9169811J	21176609J	21176619G	21176638D
3"	9169812G	21176604D	21176620D	21176639C
4"	9169813E	21176605C	21176621C	21176640K
6"	9169815K	21176606B	21176622B	21176641J
8"	9817901D	21176607A	21176623A	21176642H
10"	9817902B	21176610F	21176624K	21176643G
12"	9817903K	21176611E	21176625J	21176644F
14"	9817904H	21176612D	21176626H	21176645E
16"	9817905E	21176613C	21176627G	21176645E

Model 100-20 Hytrol Main Valve

BUNA-N MATERIAL				
	RUBBER KIT	REPAIR KIT	REBUILD KIT	STUD & NUT KIT
	STOCK NO.	STOCK NO.	STOCK NO.	STOCK NO.
3"	9169805A	21176608K	21176618H	21176637E
4"	9169812G	21176604D	21176620D	21176639C
6"	9169813E	21176605C	21176621C	21176640K
8"	9169815K	21176606B	21176622B	21176641J
10"	9817901D	21176607A	21176623A	21176642H
12"	9817902B	21176610F	21176624K	21176643G
14"	9817903K	21176611E	21176625J	21176644F
16"	9817903K	21176611E	21176625J	21176644F

Consult factory for larger sizes

Rubber Kit Includes: Diaphragm, Disc, Spacer Washers

Repair Kit Includes: Diaphragm, Disc, Spacer Washers, Epoxy Coated Disc Retainer, Epoxy Coated Diaphragm Washer, Protective Washer

Rebuild Kit Includes: Diaphragm, Disc, Spacer Washers, Epoxy Coated Disc Retainer, Epoxy Coated Diaphragm Washer, Protective Washer, Stainless Steel Bolts & Washers (6" & Below), Stainless Steel Studs, Nuts, & Washers (8" & Above), Stem, Stem Nut, Disc Guide

Stud & Nut Kit Includes: Stainless Steel Bolts & Washers (6" & Below), Stainless Steel Studs, Nuts, & Washers (8" & Above)

Repair Kits for 100-02/100-21 Powertrol and 100-03/100-22 Powercheck Main Valves

For: Powertrol and Powercheck Main Valves—150 Pressure Class Only

Includes: Diaphragm, Disc (or Disc Assembly) and O-rings and full set of spare Spacer Washers.

Valve Size	Kit Stock Number 100-02	Valve Size	Kit Stock Number	
			100-02 & 100-03	100-21 & 100-22
3/8"	9169901H	2 1/2"	9169910J	N/A
1/2" & 3/4"	9169902F	3"	9169911G	9169905J
1"	9169903D	4"	9169912E	9169911G
1 1/4" & 1 1/2"	9169904B	6"	9169913C	9169912E
2"	9169905J	8"	99116G	9169913C
		10"	9169939H	99116G
		12"	9169937B	9169939H

Larger Sizes: Consult Factory.

Repair Kits for 100-04/100-23 Hy-Check Main Valves

For: Hy-Check Main Valves—150 Pressure Class Only

Includes: Diaphragm, Disc and O-Rings and full set of spare Spacer Washers.

Valve Size	Kit Stock Number		Valve Size	Kit Stock Number	
	100-04	100-23		100-04	100-23
4"	20210901B	N/A	12"	20210905H	20210904J
6"	20210902A	20210901B	14"	20210906G	N/A
8"	20210903K	20210902A	16"	20210907F	20210905H
10"	20210904J	20210903K	20"	N/A	20210907F
			24"	N/A	20210907F

Larger Sizes: Consult Factory.

Repair Kits for Pilot Control Valves (In Standard Materials Only)

Includes: Diaphragm, Disc (or Disc Assembly), O-Rings, Gaskets or spare Screws as appropriate.

BUNA-N® (Standard Material)				VITON (For KB Controls)	
Pilot Control	Kit Stock Number	Pilot Control	Kit Stock Number	Pilot Control	Kit Stock Number
CDB	9170006C	CFM-9	12223E	CDB-KB	9170012A
CDB-30	9170023H	CRA (w/bucking spring)	9170001D	CRA-KB	N/A
CDB-31	9170024F	CRD (w/bucking spring)	9170002B	CRD-KB (w/bucking spring)	9170008J
CDB-7	9170017K	CRD (no bucking spring)	9170003K	CRL-KB	9170013J
CDH-2	18225D	CRD-18	20275401K	CDHS-2BKB	9170010E
CDHS-2	44607A	CRD-22	98923G	CDHS-2FKB	9170011C
CDHS-2B	9170004H	CRL (55F, 55L)	9170007A	CDHS-18KB (no bucking spring)	9170009G
CDHS-2F	9170005E	CRL60/55L-60	9170033G	102C-KB	1726202D
CDHS-3C-A2	24657K	CRL60/55L60 1"	9170042H		
CDHS-8A	2666901A	CRL-4A	43413E		
CDHS-18	9170003K	CRL-5 (55B)	65755B		
CDS-4	9170014G	CRL-5A (55G)	20666E		
CDS-5	14200A	CRL-18	20309801C		
CDS-6	20119301A	Universal CRL	9170041K		
CDS-6A	20349401C	CV	9170019F		
CFCM-M1	1222301C	X105L (O-ring)	00951E	Buna-N®	
CFM-2	12223E	102B-1	1502201F		
CFM-7	1263901K	102C-2	1726201F	CRD Disc Ret. (Solid)	C5256H
CFM-7A	1263901K	102C-3	1726201F	CRD Disc Ret. (Spring)	C5255K

Repair Assemblies (In Standard Materials Only)

Control	Description	Stock Number
CF1-C1	Pilot Assembly Only	89541H
CF1-CI	Complete Float Control less Ball and Rod	89016A
CFC2-C1	Disc, Distributor and Seals	2674701E
CSM 11-A2-2	Mechanical Parts Assembly	97544B
CSM 11-A2-2	Pilot Assembly Only	18053K
33A 1"	Complete Internal Assembly and Seal	2036030B
33A 2"	Complete Internal Assembly and Seal	2040830J

When ordering, please give complete nameplate data of the valve and/or control being repaired. MINIMUM ORDER CHARGE APPLIES

CLA-VAL

1701 Placentia Ave • Costa Mesa CA 92627 Phone: 949-722-4800 • Fax: 949-548-5441 • E-mail: info@cla-val.com • www.cla-val.com

© Copyright Cla-Val 2018 Printed in USA Specifications subject to change without notice.

N-RK (R-08/2018)