

CLA-VAL

AUTOMATIC CONTROL VALVES

250-01/605-01

Place this manual with personal responsible
for maintenance of this valve

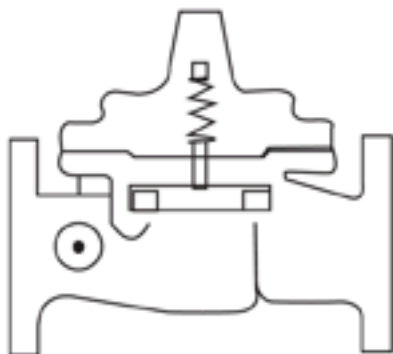

INSTALLATION

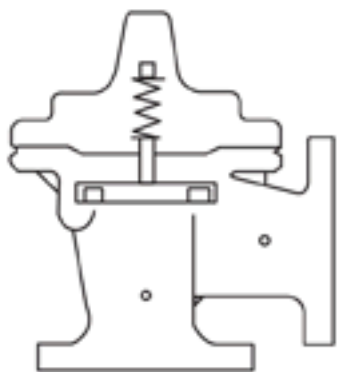

OPERATION

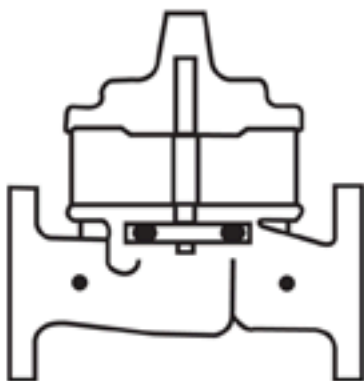

MAINTENANCE



CLA-VAL • P.O. BOX 1325 • NEWPORT, CA 92659-0325 • (949) 722-4800 • FAX: (949) 548-5441
CLA-VAL CANADA LTD. • 4687 Christie Drive • Beamsville, Ontario, LOR 1B4 Canada • (905) 563-4963



NEWPORT BEACH, CALIFORNIA

CATALOG NO. 250-01/605-01

DRAWING NO. 89993

REV. D

TYPE OF VALVE AND MAIN FEATURES

DIFFERENTIAL PRESSURE RELIEF VALVE

DESIGN		
DRAW	CH	5-9-75
CHK'D	MF	5-12-75
APVD	JAS	5-17-75

7-29-94
 CN
 ADDED 605-01 TO CAT. NO. & 100-20 HYTROL TO ITEM NO. 1
 (ECO 14846)
 D

CAD REVISION RECORD - DO NOT REVISE MANUALLY
 DESCRIPTION
 BY DATE
 A-B SEE REVISION FILE
 C ADDED D OPTIONAL FEATURE & REDRAWN ON CAD (ECO 12050) TLC 6-27-91

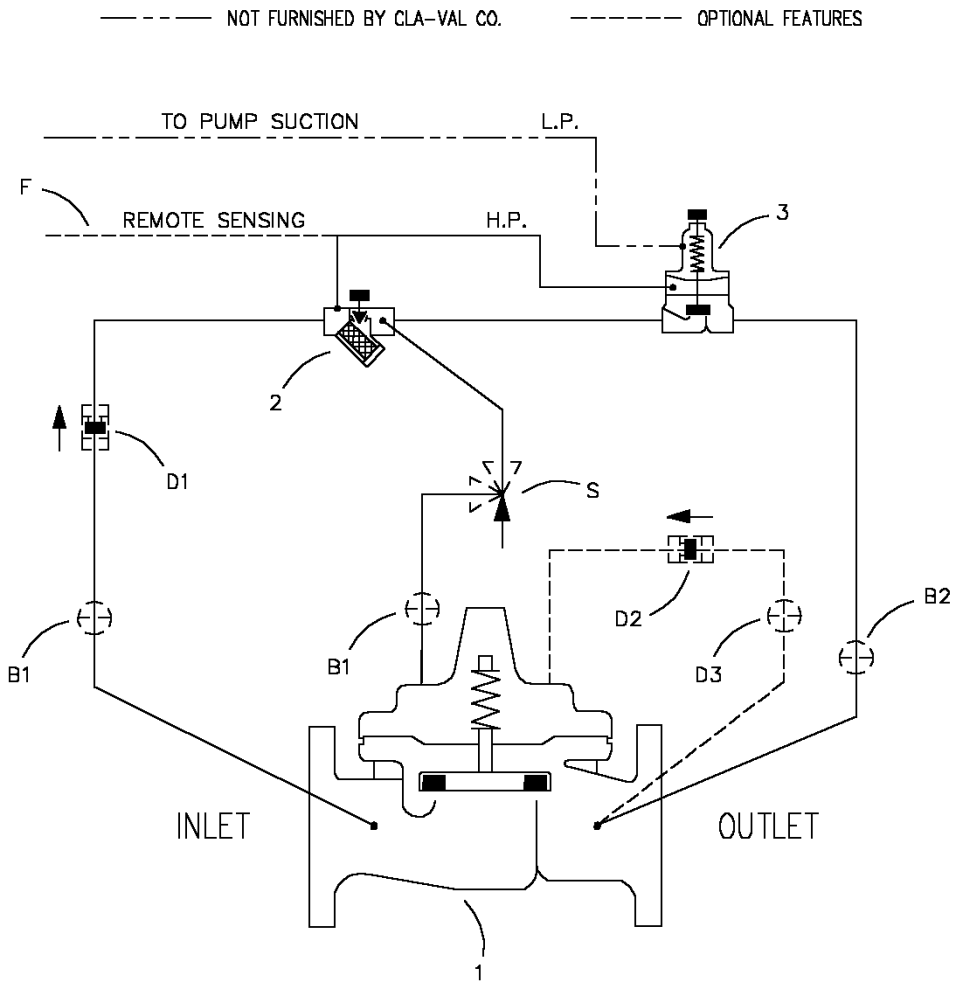

ITEM NO.	BASIC COMPONENTS	QTY
1	100-01 HYTROL (250-01) MAIN VALVE	1
	100-20 HYTROL (605-01) MAIN VALVE	
2	X42N-2 STRAINER & NEEDLE VALVE	1
3	CDB-7 DIFFERENTIAL CONTROL	1

OPTIONAL FEATURE SUFFIX		ADDED TO CATALOG NUMBER	
B	CK2 COCK (ISOLATION VALVES)	3	
D	CHECK VALVES WITH COCK	1	
F	REMOTE PILOT SENSING		
S	CV FLOW CONTROL (OPENING)	1	

THIS DRAWING IS THE PROPERTY OF CLA-VAL CO. AND SAME AND COPIES MADE THEREOF, IF ANY, SHALL BE RETURNED TO IT UPON DEMAND. DELIVERY AND DISCLOSURE HEREOF ARE SOLELY UPON CONDITION THAT THE SAME SHALL NOT BE USED, COPIED OR REPRODUCED, NOR SHALL THE SUBJECT HEREOF BE DISCLOSED IN ANY MANNER TO ANYONE FOR ANY PURPOSE, EXCEPT AS HEREIN AUTHORIZED, WITHOUT PRIOR WRITTEN APPROVAL OF CLA-VAL CO. THIS DRAWING IS SUBMITTED CONFIDENTIALLY AND MAY NOT BE USED IN THE MANUFACTURE OF ANY MATERIAL OR PRODUCT OTHER THAN SUCH MATERIALS AND PRODUCTS FURNISHED TO CLA-VAL CO. WHETHER OR NOT THE EQUIPMENT OR INFORMATION SHOWN HEREON IS PATENTED OR OTHERWISE PROTECTED, FULL TITLE AND COPYRIGHTS, IF ANY, IN AND TO THIS DRAWING AND/OR INFORMATION DELIVERED OR SUBMITTED ARE FULLY RESERVED CLA-VAL CO.



CLA-VAL CO.

NEWPORT BEACH, CALIFORNIA

CATALOG NO.
250-01/605-01

DRAWING NO.
89993

REV.
D

TYPE OF VALVE AND MAIN FEATURES

DIFFERENTIAL PRESSURE RELIEF VALVE

DESIGN		
DRAW	CH	5-9-75
CHK'D	MF	5-12-75
APVD	JAS	5-17-75

OPERATING DATA

I. DIFFERENTIAL RELIEF FEATURE:

DIFFERENTIAL RELIEF CONTROL (3) IS NORMALLY CLOSED AND RESPONDS TO DIFFERENTIAL PRESSURE CHANGES ACROSS THE DIAPHRAGM OF CONTROL (3). AN INCREASE IN DIFFERENTIAL PRESSURE TENDS TO OPEN CONTROL (3) AND A DECREASE IN DIFFERENTIAL PRESSURE TENDS TO CLOSE CONTROL (3). THIS CAUSES MAIN VALVE COVER PRESSURE TO VARY AND THE MAIN VALVE MODULATES (OPENS AND CLOSES) MAINTAINING A RELATIVELY CONSTANT DIFFERENTIAL PRESSURE BETWEEN PUMP SUCTION AND THE MAIN VALVE INLET (PUMP DISCHARGE). WHEN DIFFERENTIAL PRESSURE IS LOWER THAN THE SET POINT OF CONTROL (3), CONTROL (3) CLOSSES. THIS PRESSURIZES THE COVER OF THE MAIN VALVE AND THE MAIN VALVE CLOSSES. DIFFERENTIAL CONTROL ADJUSTMENT: TURN THE ADJUSTING SCREW CLOCKWISE TO INCREASE THE SETTING.

II. CLOSING SPEED CONTROL:

NEEDLE VALVE (2) CONTROLS THE CLOSING SPEED OF THE MAIN VALVE. TURN THE ADJUSTING STEM CLOCKWISE TO MAKE THE MAIN VALVE CLOSE SLOWER. DO NOT CLOSE VALVE (2) COMPLETELY OR THE MAIN VALVE WILL NOT CLOSE. (SUGGESTED INITIAL SETTING OF NEEDLE VALVE IS 1/4 TO 1/2 TURN OPEN.)

III. OPTIONAL FEATURE OPERATING DATA:

SUFFIX B (ISOLATION VALVES)

CK2 COCKS (B1) AND (B2) ARE USED TO ISOLATE THE PILOT SYSTEM FROM MAIN LINE PRESSURE. THESE VALVES MUST BE OPEN DURING NORMAL OPERATION.

SUFFIX D (CHECK VALVES WITH COCK):

WHEN OUTLET PRESSURE IS HIGHER THAN INLET PRESSURE, CHECK VALVE (D2) OPENS AND (D1) CLOSSES. THIS DIRECTS THE HIGHER OUTLET PRESSURE INTO THE MAIN VALVE COVER AND THE MAIN VALVE CLOSSES.

SUFFIX F (REMOTE PILOT SENSING)

REMOTE SENSING PRESSURE IS OBTAINED FROM A POINT UPSTREAM OF THE MAIN VALVE INLET. [SENSING PRESSURE IS OBTAINED FROM THE MAIN VALVE INLET IF SUFFIX (F) IS NOT SPECIFIED].

CAD REVISION RECORD - DO NOT REVISE MANUALLY

DATE

BY

DESCRIPTION

LTR

SEE SHEET 1

THIS DRAWING IS THE PROPERTY OF CLA-VAL CO. AND SAME AND COPIES MADE THEREOF, IF ANY, SHALL BE RETURNED TO IT UPON DEMAND. DELIVERY AND DISCLOSURE HEREOF ARE SOLELY UPON CONDITION THAT THE SAME SHALL NOT BE USED, COPIED OR REPRODUCED, NOR SHALL THE SUBJECT HEREOF BE DISCLOSED IN ANY MANNER TO ANYONE FOR ANY PURPOSE, EXCEPT AS HEREIN AUTHORIZED, WITHOUT PRIOR WRITTEN APPROVAL OF CLA-VAL CO. THIS DRAWING IS SUBMITTED CONFIDENTIALLY AND MAY NOT BE USED IN THE MANUFACTURE OF ANY MATERIAL OR PRODUCT OTHER THAN SUCH MATERIALS AND PRODUCTS FURNISHED TO CLA-VAL CO. WHETHER OR NOT THE EQUIPMENT OR INFORMATION SHOWN HEREON IS PATENTED OR OTHERWISE PROTECTED, FULL TITLE AND COPYRIGHTS, IF ANY, IN AND TO THIS DRAWING AND/OR INFORMATION DELIVERED OR SUBMITTED ARE FULLY RESERVED CLA-VAL CO.



CLA-VAL CO.

NEWPORT BEACH, CALIFORNIA

CATALOG NO.
250-01/605-01

DRAWING NO.	REV.
89993	D

TYPE OF VALVE AND MAIN FEATURES

DIFFERENTIAL PRESSURE RELIEF VALVE

DESIGN		
DRAW	CH	5-9-75
CHK'D	MF	5-12-75
APVD	JAS	5-17-75

OPERATING DATA - CONTINUED

SUFFIX S (OPENING SPEED CONTROL)

FLOW CONTROL (S) CONTROLS THE OPENING SPEED OF THE MAIN VALVE. TURN THE ADJUSTING STEM CLOCKWISE TO MAKE THE MAIN VALVE OPEN SLOWER.

IV. CHECK LIST FOR PROPER OPERATION:

- () SYSTEM VALVES OPEN UPSTREAM AND DOWNSTREAM.
- () AIR REMOVED FROM THE MAIN VALVE COVER AND PILOT SYSTEM AT ALL HIGH POINTS.
- () CK2 COCKS (B1) & (B2) OPEN (OPTIONAL FEATURE).
- () PERIODIC CLEANING OF STRAINER (2) IS RECOMMENDED.
- () VALVE (2) OPEN AT LEAST 1/4 TURN.
- () DIFFERENTIAL CONTROL (3) TURNED TO THE SET POSITION.

CAD REVISION RECORD - DO NOT REVISE MANUALLY

DATE

BY

DESCRIPTION

LTR

SEE SHEET 1

"THIS DRAWING IS THE PROPERTY OF CLA-VAL CO. AND SAME AND COPIES MADE THEREOF, IF ANY, SHALL BE RETURNED TO IT UPON DEMAND. DELIVERY AND DISCLOSURE HEREOF ARE SOLELY UPON CONDITION THAT THE SAME SHALL NOT BE USED, COPIED OR REPRODUCED, NOR SHALL THE SUBJECT HEREOF BE DISCLOSED IN ANY MANNER TO ANYONE FOR ANY PURPOSE, EXCEPT AS HEREIN AUTHORIZED, WITHOUT PRIOR WRITTEN APPROVAL OF CLA-VAL CO. THIS DRAWING IS SUBMITTED CONFIDENTIALLY AND MAY NOT BE USED IN THE MANUFACTURE OF ANY MATERIAL OR PRODUCT OTHER THAN SUCH MATERIALS AND PRODUCTS FURNISHED TO CLA-VAL CO. WHETHER OR NOT THE EQUIPMENT OR INFORMATION SHOWN HEREON IS PATENTED OR OTHERWISE PROTECTED, FULL TITLE AND COPYRIGHTS, IF ANY, IN AND TO THIS DRAWING AND/OR INFORMATION DELIVERED OR SUBMITTED ARE FULLY RESERVED CLA-VAL CO."



250-01
(Full Internal Port)
605-01
(Reduced Internal Port)

Differential Pressure Relief Valve

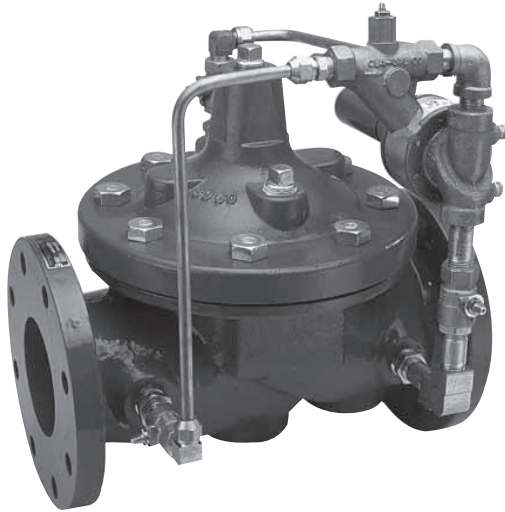

- Accurate Differential Pressure Control
- Controls Maximum Flow Through Pumps
- Circulating Loop Flow Control
- Completely Automatic Operation

The Cla-Val Model 250-01/605-01 Differential Pressure Relief Valve is a hydraulically operated, pilot-controlled, modulating valve. It is designed to maintain a constant pressure differential between any two pressure points in a system where the closing of the valve directly causes the differential pressure to increase. The valve tends to open on an increase in differential pressure and close on a decrease in differential pressure.

In operation, the valve is actuated by line pressure through a pilot control system sensing from two points across which a differential is to be maintained. Operation is completely automatic and pressure settings may be easily changed.

Schematic Diagram

Item	Description
1	Hytrol (Main Valve)
2	X42N-2 Strainer & Needle Valve
3	CDB-7 Differential Control

Optional Features

Item	Description
B	CK2 (Isolation Valve)
D	Check Valves with Isolation Valve
F	Remote Pilot Sensing (H.P.)
S	CV Speed Control (Opening)

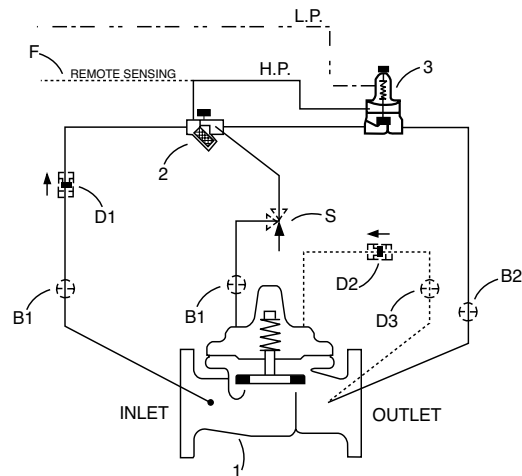

Typical Applications

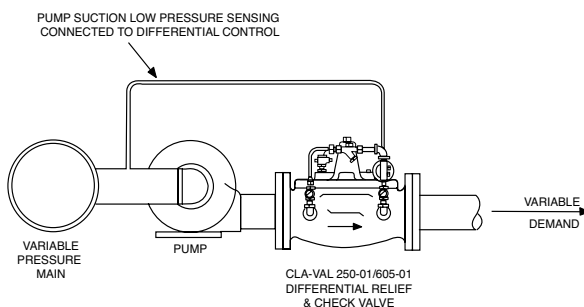

The Model 250-01/605-01 Differential Pressure Relief Valve maintains a constant differential across centrifugal pump regardless of variable upstream pressures or downstream demand. By maintaining a constant differential pressure across a centrifugal pump operating at a known capacity, the maximum flow rate is controlled.

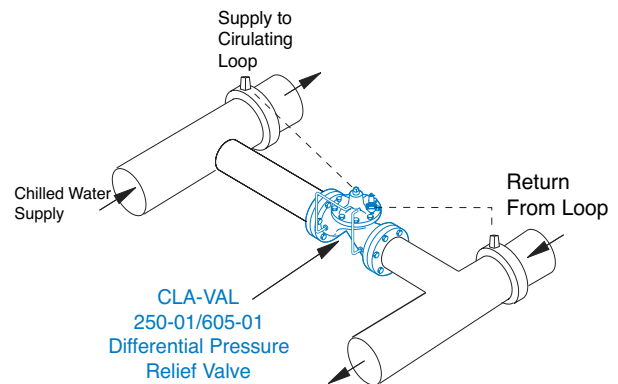

On a chilled water circulating loop system the 250-01/605-01 Differential Pressure Relief Valve is installed between loop supply and return lines to maintain a constant differential across the loop. The loop differential pressure remains constant regardless of the loop demand change thereby increasing cooling system efficiency.



Model 250-01 (Uses Basic Valve Model 100-01)

Pressure Ratings (Recommended Maximum Pressure - psi)

Valve Body & Cover		Pressure Class			
		Flanged			Threaded
Grade	Material	ANSI Standards*	150 lb.	300 lb.	End**
ASTM A536	Ductile Iron	B16.42	250	400	400
ASTM A216-WCB	Cast Steel	B16.5	285	400	400
ASTM B62	Bronze	B16.24	225	400	400

Note: * ANSI standards are for flange dimensions only.
 Flanged valves are available faced but not drilled.
 ** End Details machined to ANSI B2.1 specifications.

Materials

Component	Standard Material Combinations		
Body & Cover	Ductile Iron	Cast Steel	Bronze
Available Sizes	1½" - 36"	1½" - 16"	1½" - 16"
Disc Retainer & Diaphragm Washer	Cast Iron	Cast Steel	Bronze
Trim: Disc Guide, Seat & Cover Bearing	Bronze is Standard Stainless Steel is Optional		
Disc	Buna-N® Rubber		
Diaphragm	Nylon Reinforced Buna-N® Rubber		
Stem, Nut & Spring	Stainless Steel		

For material options not listed, consult factory.
 Cla-Val manufactures valves in more than 50 different alloys.

Dimensions
(In inches)

100-01 (Globe)

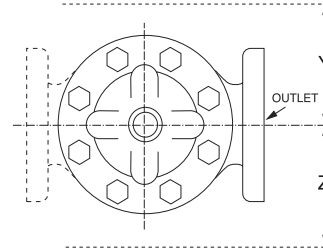
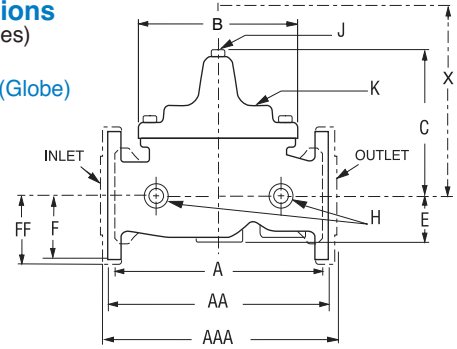

100-01 (Angle)

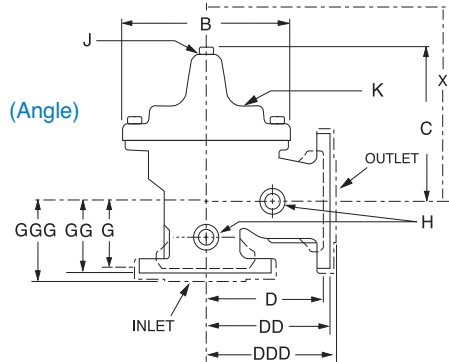

***Consult Factory

Model 250-01 Dimensions (In Inches)

Valve Size (Inches)	1½-1½	2	2 ½	3	4	6	8	10	12	14	16	24	30***	36***
A Threaded	7.25	9.38	11.00	12.50	—	—	—	—	—	—	—	—	—	—
AA 150 ANSI	8.50*	9.38	11.00	12.00	15.00	20.00	25.38	29.75	34.00	39.00	41.38	61.50	63.00	76.00
AAA 300 ANSI	9.00*	10.00	11.62	13.25	15.62	21.00	26.38	31.12	35.50	40.50	43.50	63.24	64.50	78.00
B Dia.	5.62	6.62	8.00	9.12	11.50	15.75	20.00	23.62	28.00	32.75	35.50	53.16	56.00	66.00
C Max.	5.50	6.50	7.56	8.19	10.62	13.38	16.00	17.12	20.88	24.19	25.00	43.93	54.60	61.50
D Threaded	3.25	4.75	5.50	6.25	—	—	—	—	—	—	—	—	—	—
DD 150 ANSI	4.00*	4.75	5.50	6.00	7.50	10.00	12.75	14.88	17.00	19.50	20.81	—	—	—
DDD 300 ANSI	4.25*	5.00	5.88	6.38	7.88	10.50	13.25	15.56	17.75	20.25	21.62	—	—	—
E	1.12	1.50	1.69	2.06	3.19	4.31	5.31	9.25	10.75	12.62	15.50	17.75	21.31	24.56
F 150 ANSI	2.50	3.00	3.50	3.75	4.50	5.50	6.75	8.00	9.50	10.50	11.75	19.25	22.50	25.60
FF 300 ANSI	3.06	3.25	3.75	4.13	5.00	6.25	7.50	8.75	10.25	11.50	12.75	19.25	24.00	25.60
G Threaded	1.88	3.25	4.00	4.50	—	—	—	—	—	—	—	—	—	—
GG 150 ANSI	4.00*	3.25	4.00	4.00	5.00	6.00	8.00	8.62	13.75	14.88	15.69	—	—	—
GGG 300 ANSI	4.25*	3.50	4.31	4.38	5.31	6.50	8.50	9.31	14.50	15.62	16.50	—	—	—
H NPT Body Tapping	¾	¾	½	½	¾	¾	1	1	1	1	1	1	2	2
J NPT Cover Center Plug	¼	½	½	½	¾	¾	1	1	1¼	1½	2	1½	2	2
K NPT Cover Tapping	¾	¾	½	½	¾	¾	1	1	1	1	1	1	2	2
Valve Stem Internal Thread UNF	10-32	10-32	10-32	¼-28	¼-28	¾-24	¾-24	¾-24	¾-24	¾-24	¾-24	½-20	¾-16	¾-16
Stem Travel	0.4	0.6	0.7	0.8	1.1	1.7	2.3	2.8	3.4	4.0	4.5	6.75	7.5	8.5
Approx. Ship Wt. Lbs.	15	35	50	70	140	285	500	780	1165	1600	2265	6200	7703	11720
X Pilot System	11.00	13.00	14.00	15.00	17.00	29.00	31.00	33.00	36.00	40.00	40.00	68.00	79.00	85.00
Y Pilot System	9.00	9.00	10.00	11.00	12.00	20.00	22.00	24.00	26.00	29.00	30.00	39.00	40.00	45.00
Z Pilot System	9.00	9.00	10.00	11.00	12.00	20.00	22.00	24.00	26.00	29.00	30.00	39.00	42.00	47.00

*1½" Size Only

Note: The top two flange holes on valve size 36 are threaded to 1 1/2"-6 UNC.

Model 605-01 (Uses Basic Valve Model 100-20)

Dimensions
(In inches)

Pressure Ratings (Recommended Maximum Pressure - psi)

Valve Body & Cover		Pressure Class		
		Flanged		
Grade	Material	ANSI Standards*	150 lb.	300 lb.
ASTM A536	Ductile Iron	B16.42	250	400
ASTM A216-WCB	Cast Steel	B16.5	285	400
ASTM B62	Bronze	B16.24	225	400

Note: *ANSI standards are for flange dimensions only.
Flanged valves are available faced but not drilled.

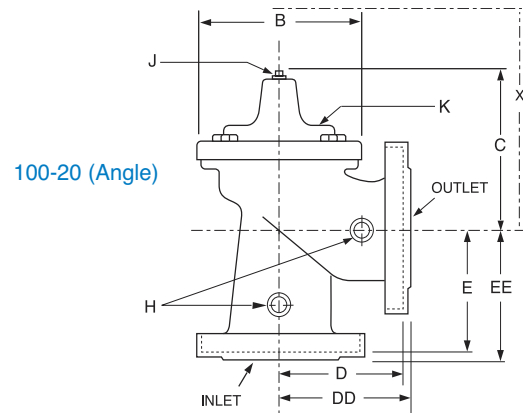
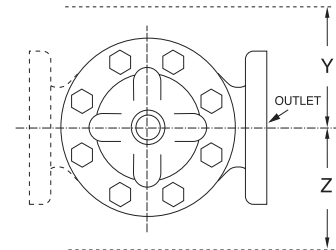
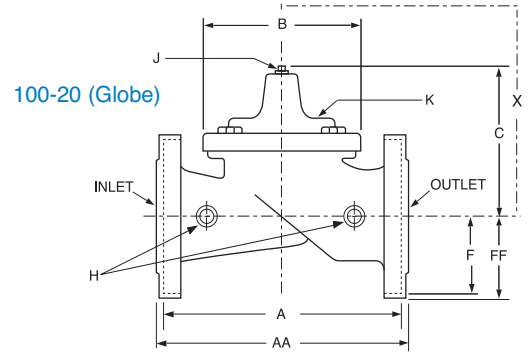

Materials

Component	Standard Material Combinations		
Body & Cover	Ductile Iron	Cast Steel	Bronze
Available Sizes	3" - 48"	3" - 16"	3" - 16"
Disc Retainer & Diaphragm Washer	Cast Iron	Cast Steel	Bronze
Trim: Disc Guide, Seat & Cover Bearing	Bronze is Standard Stainless Steel is Optional		
Disc	Buna-N® Rubber		
Diaphragm	Nylon Reinforced Buna-N® Rubber		
Stem, Nut & Spring	Stainless Steel		











































For material options not listed, consult factory.
Cla-Val manufactures valves in more than 50 different alloys.

Model 605-01 Dimensions (In Inches)

Valve Size (Inches)	3	4	6	8	10	12	14	16	18	20	24	30	36***	42***	48***
A 150 ANSI	10.25	13.88	17.75	21.38	26.00	30.00	34.25	35.00	42.12	48.00	48.00	63.25	65.00	76.00	94.50
AA 300 ANSI	11.00	14.50	18.62	22.38	27.38	31.50	—	36.62	43.63	49.62	49.75	63.75	67.00	76.00	94.50
B Dia.	6.62	9.12	11.50	15.75	20.00	23.62	27.47	28.00	35.44	35.44	35.44	53.19	56.00	66.00	66.00
C Max.	7.00	8.62	11.62	15.00	17.88	21.00	20.88	25.75	25.00	31.00	31.00	43.94	54.60	61.50	61.50
D 150 ANSI	—	6.94	8.88	10.69	—	—	—	—	—	—	—	—	—	—	—
DD 300 ANSI	—	7.25	9.38	11.19	—	—	—	—	—	—	—	—	—	—	—
E 150 ANSI	—	5.50	6.75	7.25	—	—	—	—	—	—	—	—	—	—	—
EE 300 ANSI	—	5.81	7.25	7.75	—	—	—	—	—	—	—	—	—	—	—
F 150 ANSI	3.75	4.50	5.50	6.75	8.00	9.50	11.00	11.75	15.88	14.56	17.00	19.88	25.50	28.00	31.50
FF 300 ANSI	4.12	5.00	6.25	7.50	8.75	10.25	—	12.75	15.88	16.06	19.00	22.00	27.50	28.00	31.50
H NPT Body Tapping	½	½	¾	¾	1	1	1	1	1	1	1	1	2	2	2
J NPT Cover Center Plug	½	½	¾	¾	1	1	1 ¼	1 ¼	2	2	2	2	2	2	2
K NPT Cover Tapping	¾	½	¾	¾	1	1	1	1	1	1	1	1	2	2	2
Valve Stem Internal Thread UNF	10-32	¼-28	¼-28	¾-24	¾-24	¾-24	¾-24	¾-24	½-20	½-20	½-20	¾-16	¾-16	M20	M20
Stem Travel	0.6	0.8	1.1	1.7	2.3	2.8	3.4	3.4	3.4	4.5	4.5	6.5	7.5	8.5	8.5
Approx. Ship Wt. Lbs.	45	85	195	330	625	900	1250	1380	1500	2551	2733	6500	8545	12450	13100
X Pilot System	13.00	15.00	27.00	30.00	33.00	36.00	36.00	41.00	40.00	46.00	55.00	68.00	79.00	85.00	86.00
Y Pilot System	10.00	11.00	18.00	20.00	22.00	24.00	26.00	26.00	30.00	30.00	30.00	39.00	40.00	45.00	47.00
Z Pilot System	10.00	11.00	18.00	20.00	22.00	24.00	26.00	26.00	30.00	30.00	30.00	39.00	42.00	47.00	49.00

Note: The top two flange holes on valve sizes 36 thru 48 are threaded to 1 1/2"-6 UNC.

***Consult Factory

Valve Selection		These Symbols  and  Indicate Available Sizes																						
		Inches	1 ¼	1 ½	2	2 ½	3	4	6	8	10	12	14	16	18	20	24	30	36	42	48			
		mm	32	40	50	65	80	100	150	200	250	300	350	400	450	500	600	750	900	1000	1200			
End Detail		Threaded	Threaded & Flanged						Flanged															
Model 250-01 Series	Basic Valve 100-01	Globe																						
		Angle																						
	Suggested Flow (gpm)	Max. Continuous	93	125	210	300	460	800	1800	3100	4900	7000	8400	11000			25000							
		Max. Surge	120	280	470	670	1000	1800	4000	7000	11000	16000	19000	25000			56500							
	Suggested Flow (Liters/Sec)	Max. Continuous	6	8	13	19	29	50	113	195	309	441	529	693			1575							
		Max. Surge	13	18	30	42	63	113	252	441	693	1008	1197	1575			3560							
	Consult Factory for Sizes Not Shown																							
	Model 605-01 Series	Basic Valve 100-20	Globe																					
Angle																								
Suggested Flow (gpm)		Max. Continuous					260	580	1025	2300	4100	6400	9230	9230	16500	16500	16500	31300						
		Max. Surge					440	990	1760	3970	7050	11000	15900	15900	28200	28200	28200	56500						
Suggested Flow (Liters/Sec)		Max. Continuous					16	37	65	145	258	403	581	581	1040	1040	1040	1972						
		Max. Surge					28	62	111	250	444	693	1002	1002	1777	1777	1777	3560						

**Flanged End Detail Only

605-01 is the reduced internal port size version of the 250-01.

For 100-01 basic valves, suggested, flow calculations were based on flow through Schedule 40 Pipe. Maximum continuous flow is approx. 20 ft/sec (6.1 meters/sec) & maximum surge is approx. 45 ft/sec (13.7 meters/sec). For 100-20 basic valves, suggested, flow calculations were based on flow through the valve seat. Approx. 26 ft/sec (7.9 meters/sec) is used for continuous flow & 45 ft/sec (13.7 meters/sec) is used for surge flow. Maximum continuous flow through the valve seat for the 30" 100-20 is approx. 22 ft/sec (6.7 meters/sec).

Pilot System Specifications

Adjustment Ranges (Differential Pressure)

0 to 7 psi 50 to 150 psi
 5 to 25 psi 65 to 180 psi
 20 to 80 psi

Temperature Range

Water: to 180°F

Materials

Standard Pilot System Materials
 Pilot Control: Bronze ASTM B62
 Trim: Stainless Steel Type 303
 Rubber: Buna-N® Synthetic Rubber
 Tubing & Fittings: Copper and Bronze

Optional Pilot System Materials
 Pilot Systems are available with optional Aluminum, Stainless Steel or Monel materials at additional cost.

When Ordering, Please Specify

1. Catalog No. 250-01 or No. 605-01
2. Valve Size
3. Pattern - Globe or Angle
4. Pressure Class
5. Threaded or Flanged
6. Trim Material
7. Adjustment Range
8. Desired Options
9. When Vertically Installed



CLA-VAL

PO Box 1325 Newport Beach CA 92659-0325
 Phone: 949-722-4800 • Fax: 949-548-5441

CLA-VAL CANADA

4687 Christie Drive
 Beamsville, Ontario
 Canada LOR 1B4
 Phone: 905-563-4963
 Fax: 905-563-4040

CLA-VAL EUROPE

Chemin des Mesanges 1
 CH-1032 Romanel/
 Lausanne, Switzerland
 Phone: 41-21-643-15-55
 Fax: 41-21-643-15-50

©COPYRIGHT CLA-VAL 2008 Printed in USA
 Specifications subject to change without notice.

www.cla-val.com

Represented By:



—MODEL— **100-01**
Hytrol Valve

Description

The Cla-Val Model 100-01 Hytrol Valve is a main valve for Cla-Val Automatic Control Valves. It is a hydraulically operated, diaphragm-actuated, globe or angle pattern valve.

This valve consists of three major components; body, diaphragm assembly, and cover. The diaphragm assembly is the only moving part. The diaphragm assembly uses a diaphragm of nylon fabric bonded with synthetic rubber. A synthetic rubber disc, contained on three and one half sides by a disc retainer and disc guide, forms a seal with the valve seat when pressure is applied above the diaphragm. The diaphragm assembly forms a sealed chamber in the upper portion of the valve, separating operating pressure from line pressure.

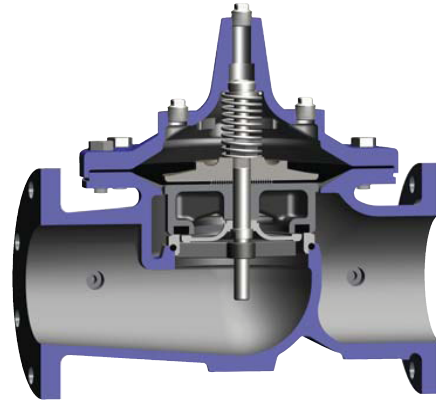

Installation

1. Before valve is installed, pipe lines should be flushed of all chips, scale and foreign matter.
2. It is recommended that either gate or block valves be installed on both ends of the 100-01 Hytrol Valve to facilitate isolating the valve for preventive maintenance and repairs.
3. Place the valve in the line with flow through the valve in the direction indicated on the inlet nameplate. (See "Flow Direction" Section)
4. Allow sufficient room around valve to make adjustments and for disassembly.
5. Cla-Val 100-01 Hytrol Valves operate with maximum efficiency when mounted in horizontal piping with the cover UP, however, other positions are acceptable. Due to size and weight of the cover and internal components of 8 inch and larger valves,

installation with the cover UP is advisable. This makes internal parts readily accessible for periodic inspection.

6. Caution must be taken in the installation of this valve to insure that galvanic and/or electrolytic action does not take place. The proper use of dielectric fittings and gaskets are required in all systems using dissimilar metals.
7. If a pilot control system is installed on the 100-01 Hytrol Valve, use care to prevent damage. If it is necessary to remove fittings or components, be sure they are kept clean and replaced exactly as they were.
8. After the valve is installed and the system is first pressurized, vent air from the cover chamber and pilot system tubing by loosening fittings at all high points.

Principles of Operation

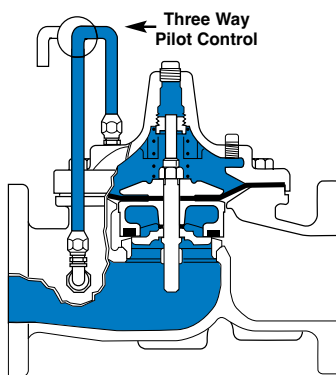

Tight Closing Operation

When pressure from the valve inlet (or an equivalent independent operating pressure) is applied to the diaphragm chamber the valve closes drip-tight.

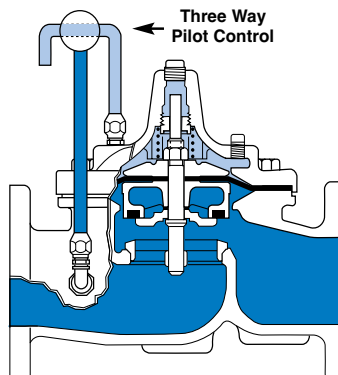

Full Open Operation

When pressure in diaphragm chamber is relieved to a zone of lower pressure (usually atmosphere) the line pressure (5 psi Min.) at the valve inlet opens the valve.

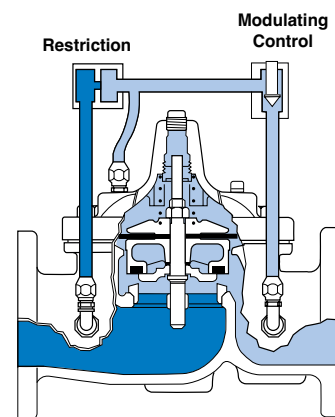

Modulating Action

Valve modulates when diaphragm pressure is held at an intermediate point between inlet and discharge pressure. With the use of a Cla-Val, "modulating control," which reacts to line pressure changes, the pressure above the diaphragm is varied, allowing the valve to throttle and compensate for the change.

Flow Direction

The flow through the 100-01 Hytrol Valve can be in one of two directions. When flow is “up-and-over the seat,” it is in “normal” flow and the valve will fail in the open position. When flow is “over-the seat-and down,” it is in “reverse” flow and the valve will fail in the closed position. There are no permanent flow arrow markings.

The valve must be installed according to nameplate data.

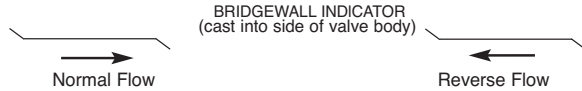

Recommended Tools

1. Three pressure gauges with ranges suitable to the installation to be put at Hytrol inlet, outlet and cover connections.
2. Cla-Val Model X101 Valve Position Indicator. This provides visual indication of valve position without disassembly of valve.
3. Other items are: suitable hand tools such as screwdrivers, wrenches, etc. soft jawed (brass or aluminum) vise, 400 grit wet or dry sandpaper and water for cleaning.

Troubleshooting

The following troubleshooting information deals strictly with the Model 100-01 Hytrol Valve. This assumes that all other components of the pilot control system have been checked out and are in proper working condition. (See appropriate sections in Technical Manual for complete valve).

All trouble shooting is possible without removing the valve from the line or removing the cover. It is highly recommended to permanently install a Model X101 Valve Position Indicator and three gauges in unused Hytrol inlet, outlet and cover connections.

SYMPTOM	PROBABLE CAUSE	REMEDY
Fails to Close	Closed isolation valves in control system, or in main line.	Open Isolation valves.
	Lack of cover chamber pressure.	Check upstream pressure, pilot system, strainer, tubing, valves, or needle valves for obstruction.
	Diaphragm damaged. (See Diaphragm Check.)	Replace diaphragm.
	Diaphragm assembly inoperative. Corrosion or excessive scale build up on valve stem. (See Freedom of Movement Check)	Clean and polish stem. Inspect and replace any damaged or badly eroded part.
	Mechanical obstruction. Object lodged in valve. (See Freedom of Movement Check)	Remove obstruction.
	Worn disc. (See Tight Sealing Check)	Replace disc.
	Badly scored seat. (See Tight Sealing Check)	Replace seat.
Fails to Open	Closed upstream and/or downstream isolation valves in main line.	Open isolation valves.
	Insufficient line pressure.	Check upstream pressure. (Minimum 5 psi flowing line pressure differential.)
	Diaphragm assembly inoperative. Corrosion or excessive buildup on valve stem. (See Freedom of Movement Check)	Clean and polish stem. Inspect and replace any damaged or badly eroded part.
	Diaphragm damaged. (For valves in "reverse flow" only)	Replace diaphragm.

After checking out probable causes and remedies, the following three checks can be used to diagnose the nature of the problem before maintenance is started. They must be done in the order shown.

Three Checks

The 100-01 Hytrol Valve has only one moving part (the diaphragm and disc assembly). So, there are only three major types of problems to be considered.

First: Valve is stuck - that is, the diaphragm assembly is not free to move through a full stroke either from open to close or vice versa.

Second: Valve is free to move and can't close because of a worn out diaphragm.

Third: Valve leaks even though it is free to move and the diaphragm isn't leaking.

CAUTION:

*Care should be taken when doing the troubleshooting checks on the 100-01 Hytrol Valve. These checks do require the valve to open fully. This will either allow a high flow rate through the valve, or the downstream pressure will quickly increase to the inlet pressure. In some cases, this can be very harmful. Where this is the case, and there are no block valves in the system to protect the downstream piping, it should be realized that **the valve cannot be serviced under pressure**. Steps should be taken to remedy this situation before proceeding any further.*

Diaphragm Check (#1)

1. Shut off pressure to the Hytrol Valve by slowly closing upstream and downstream isolation valves. **SEE CAUTION.**
2. Disconnect or close all pilot control lines to the valve cover and leave only one fitting in highest point of cover open to atmosphere.
3. With the cover vented to atmosphere, slowly open upstream isolation valve to allow some pressure into the Hytrol Valve body. Observe the open cover tapping for signs of continuous flow. It is not necessary to fully open isolating valve. Volume in cover chamber capacity chart will be displaced as valve moves to open position. Allow sufficient time for diaphragm assembly to shift positions. If there is no continuous flow, you can be quite certain the diaphragm is sound and the diaphragm assembly is tight. If the fluid appears to flow continuously this is a good reason to believe the diaphragm is either damaged or it is loose on the stem. In either case, this is sufficient cause to remove the valve cover and investigate the leakage. (See "Maintenance" Section for procedure.)

COVER CHAMBER CAPACITY

(Liquid Volume displaced when valve opens)

Valve size (inches)	Displacement	
	Gallons	Liters
1 1/4	.020	.07
1 1/2	.020	.07
2	.032	.12
2 1/2	.043	.16
3	.080	.30
4	.169	.64
6	.531	2.0
8	1.26	4.8
10	2.51	9.5
12	4.00	15.1
14	6.50	24.6
16	9.57	36.2
24	29.00	109.8
30	42.00	197.0
36	90.00	340.0

Freedom of Movement Check (#2)

4. Determining the Hytrol Valve's freedom of movement can be done by one of two methods.
5. For most valves it can be done after completing Diaphragm Check (Steps 1, 2, and 3). **SEE CAUTION.** At the end of step 3 the valve should be fully open.
6. If the valve has a Cla-Val X101 Position Indicator, observe the indicator to see that the valve opens wide. Mark the point of maximum opening.
7. Re-connect enough of the control system to permit the application of inlet pressure to the cover. Open pilot system cock so pressure flows from the inlet into the cover.
8. While pressure is building up in the cover, the valve should close smoothly. There is a hesitation in every Hytrol Valve closure, which can be mistaken for a mechanical bind. The stem will appear to stop moving very briefly before going to the closed position. This slight pause is caused by the diaphragm flexing at a particular point in the valve's travel and is not caused by a mechanical bind.
9. When closed, a mark should be made on the X101 Valve position indicator corresponding to the "closed" position. The distance between the two marks should be approximately the stem travel shown in chart.

STEM TRAVEL

(Fully Open to Fully Closed)

Valve Size (inches)		Travel (inches)	
Inches	MM	Inches	MM
1 1/4	32	0.4	10
1 1/2	40	0.4	10
2	50	0.6	15
2 1/2	65	0.7	18
3	80	0.8	20
4	100	1.1	28
6	150	1.7	43
8	200	2.3	58
10	250	2.8	71
12	300	3.4	86
14	350	4.0	100
16	400	4.5	114
24	600	6.5	165
30	800	7.5	190
36	900	8.5	216

10. If the stroke is different than that shown in stem travel chart this is a good reason to believe something is mechanically restricting the stroke of the valve at one end of its travel. If the flow does not stop through the valve when in the indicated "closed" position, the obstruction probably is between the disc and the seat. If the flow does stop, then the obstruction is more likely in the cover. In either case, the cover must be removed, and the obstruction located and removed. The stem should also be checked for scale build-up. (See "Maintenance, section for procedure.)

11. For valves 6" and smaller, the Hytrol Valve's freedom of movement check can also be done after all pressure is removed from the valve. **SEE CAUTION.** After closing inlet and outlet isolation valves and bleeding pressure from the valve, check that the cover chamber and the body are temporarily vented to atmosphere. Insert fabricated tool into threaded hole in top of valve stem, and lift the diaphragm assembly manually. Note any roughness. The diaphragm assembly should move smoothly throughout entire valve stroke. The tool is fabricated from rod that is threaded on one end to fit valve stem and has a "T" bar handle of some kind on the other end for easy gripping. (See chart in Step 4 of "Disassembly" Section.)

12. Place marks on this diaphragm assembly lifting tool when the valve is closed and when manually positioned open. The distance between the two marks should be approximately the stem travel shown in stem travel chart. If the stroke is different than that shown, there is a good reason to believe something is mechanically restricting the stroke of the valve. The cover must be removed, and the obstruction located and removed. The stem should also be checked for scale build-up. (See "Maintenance" Section for procedure.)

Tight Sealing Check (#3)

13. Test for seat leakage after completing checks #1 & #2 (Steps 1 to 12). **SEE CAUTION.** Close the isolation valve downstream of the Hytrol Valve. Apply inlet pressure to the cover of the valve, wait until it closes. Install a pressure gauge between the two closed valves using one of the two ports in the outlet side of the Hytrol. Watch the pressure gauge. If the pressure begins to climb, then either the downstream isolation valve is permitting pressure to creep back, or the Hytrol is allowing pressure to go through it. Usually the pressure at the Hytrol inlet will be higher than on the isolation valve discharge, so if the pressure goes up to the inlet pressure, you can be sure the Hytrol is leaking. Install another gauge downstream of isolating valve. If the pressure between the valves only goes up to the pressure on the isolation valve discharge, the Hytrol Valve is holding tight, and it was just the isolation valve leaking.

Maintenance

Preventative Maintenance

The Cla-Val Co. Model 100-01 Hytrol Valve requires no lubrication or packing and a minimum of maintenance. However, a periodic inspection schedule should be established to determine how the operating conditions of the system are affecting the valve. The effect of these actions must be determined by inspection.

Disassembly

Inspection or maintenance can be accomplished without removing the valve from the line. Repair kits with new diaphragm and disc are recommended to be on hand before work begins.

WARNING: Maintenance personnel can be injured and equipment damaged if disassembly is attempted with pressure in the valve. **SEE CAUTION.**

1. Close upstream and downstream isolation valves **and independent operating pressure when used** to shut off all pressure to the valve.
2. Loosen tube fittings in the pilot system to remove pressure from valve body and cover chamber. After pressure has been released from the valve, use care to remove the controls and tubing. Note and sketch position of tubing and controls for re-assembly. The schematic in front of the Technical Manual can be used as a guide when reassembling pilot system.
3. Remove cover nuts and remove cover. If the valve has been in service for any length of time, chances are the cover will have to be loosened by driving upward along the edge of the cover with a **dull cold chisel**.

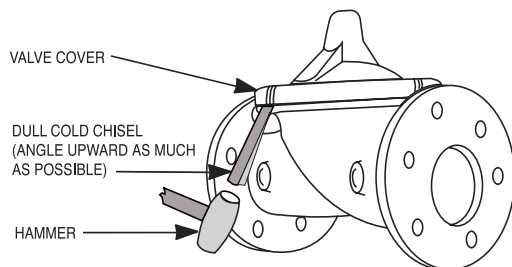

On 6" and smaller valves block and tackle or a power hoist can be used to lift valve cover by inserting proper size eye bolt in place of the center cover plug. On 8" and larger valves there are 4 holes (5/8" - 1 1/2" size) where jacking screws and/or eye bolts may be inserted for lifting purposes. **Pull cover straight up** to keep from damaging the integral seat bearing and stem.

COVER CENTER PLUG SIZE

Valve Size	Thread Size (NPT)
1 1/4" - 1 1/2"	1/4"
2" - 3"	1/2"
4" - 6"	3/4"
8" - 10"	1"
12"	1 1/4"
14"	1 1/2"
16"	2"
24"	2"
30" & 36"	2"

4. Remove the diaphragm and disc assembly from the valve body. With smaller valves this can be accomplished by hand by **pulling straight up on the stem so as not to damage the seat bearing**. On large valves, an eye bolt of proper size can be installed in the stem and the diaphragm assembly can be then lifted with a block and tackle or power hoist. Take care not to damage the stem or bearings. The valve won't work if these are damaged.

VALVE STEM THREAD SIZE

Valve Size	Thread Size (UNF Internal)
1 1/4" - 2 1/2"	10-32
3" - 4"	1/4-28
6" - 14"	3/8-24
16"	1/2-20
24"	3/4-16
30"	3/4-16
36"	3/4-16

5. The next item to remove is the stem nut. Examine the stem threads above the nut for signs of mineral deposits or corrosion. If the threads are not clean, use a wire brush to remove as much of the residue as possible. Attach a good fitting wrench to the nut and give it a sharp "rap" rather than a steady pull. Usually several blows are sufficient to loosen the nut for further removal. On the smaller valves, the entire diaphragm assembly can be held by the stem in a vise **equipped with soft brass jaws** before removing the stem nut.

The use of a pipe wrench or a vise without soft brass jaws scars the fine finish on the stem. No amount of careful dressing can restore the stem to its original condition. Damage to the finish of the stem can cause the stem to bind in the bearings and the valve will not open or close.

6. After the stem nut has been removed, the diaphragm assembly breaks down into its component parts. Removal of the disc from the disc retainer can be a problem if the valve has been in service for a long time. Using two screwdrivers inserted along the outside edge of the disc usually will accomplish its removal. Care should be taken to preserve the spacer washers in water, particularly if no new ones are available for re-assembly.

7. The only part left in the valve body is the seat which ordinarily does not require removal. Careful cleaning and polishing of inside and outside surfaces with 400 wet/dry sandpaper will usually restore the seat's sharp edge. If, however, it is badly worn and replacement is necessary, it can be easily removed.

Seats in valve sizes 1 1/4" through 6" are threaded into the valve body. They can be removed with accessory X109 Seat Removing Tool available from the factory. On 8" and larger valves, the seat is held in place by flat head machine screws. Use a tight-fitting, long shank screwdriver to prevent damage to seat screws. If upon removal of the screws the seat cannot be lifted out, it will be necessary to use a piece of angle or channel iron with a hole drilled in the center. Place it across the body so a long stud can be inserted through the center hole in the seat and the hole in the angle iron. By tightening the nut a uniform upward force is exerted on the seat for removal.

NOTE: Do not lift up on the end of the angle iron as this may force the integral bearing out of alignment, causing the stem to bind.

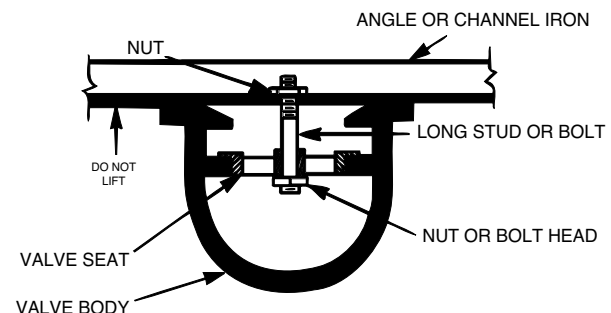

Lime Deposits

One of the easiest ways to remove lime deposits from the valve stem or other metal parts is to dip them in a 5-percent muriatic acid solution just long enough for the deposit to dissolve. This will remove most of the common types of deposits. **CAUTION: USE EXTREME CARE WHEN HANDLING ACID.** Rinse parts in water before handling. If the deposit is not removed by acid, then a fine grit (400) wet or dry sandpaper can be used with water.

Inspection of Parts

After the valve has been disassembled, each part should be examined carefully for signs of wear, corrosion, or any other abnormal condition. Usually, it is a good idea to replace the rubber parts (diaphragm and disc) unless they are free of signs of wear. These are available in a repair kit. Any other parts which appear doubtful should be replaced. **WHEN ORDERING PARTS, BE SURE TO GIVE COMPLETE NAMEPLATE DATA, ITEM NUMBER AND DESCRIPTION.**

NOTE: If a new disc isn't available, the existing disc can be turned over, exposing the unused surface for contact with the seat. The disc should be replaced as soon as practical.

Reassembly

1. Reassembly is the reverse of the disassembly procedure. If a new disc has been installed, it may require a different number of spacer washers to obtain the right amount of "grip" on the disc. When the diaphragm assembly has been tightened to a point where the diaphragm cannot be twisted, the disc should be compressed very slightly by the disc guide. Excessive compression should be avoided. Use just enough spacer washers to hold the disc firmly without noticeable compression.

2. **MAKE SURE THE STEM NUT IS VERY TIGHT.** Attach a good fitting wrench to the nut and give it a sharp "rap" rather than a steady pull. Usually several blows are sufficient to tighten the stem nut for final tightening. Failure to do so could allow the diaphragm to pull loose and tear when subjected to pressure.

3. Carefully install the diaphragm assembly by lowering the stem through the seat bearing. Take care not to damage the stem or bearing. Line up the diaphragm holes with the stud or bolt holes on the body. on larger valves with studs, it may be necessary to hold the diaphragm assembly up part way while putting the diaphragm over the studs.

4. Put spring in place and replace cover. Make sure diaphragm is lying smooth under the cover.

5. Tighten cover nuts firmly using a cross-over pattern until all nuts are tight.

6. Test Hytrol Valve before re-installing pilot valve system.

Test Procedure After Valve Assembly

There are a few simple tests which can be made in the field to make sure the Hytrol Valve has been assembled properly. Do these before installing pilot system and returning valve to service. These are similar to the three troubleshooting tests.

1. Check the diaphragm assembly for freedom of movement after all pressure is removed from the valve. **SEE CAUTION.** Insert fabricated tool into threaded hole in top of valve stem, and lift the diaphragm assembly manually. Note any roughness, sticking or grabbing. The diaphragm assembly should move smoothly throughout entire valve stroke. The tool is fabricated from rod that is threaded on one end to fit valve stem (See chart in Step 4 of "Disassembly" section.) and has a "T" Bar handle of some kind on the other end for easy gripping.

Place marks on this diaphragm assembly lifting tool when the valve is closed and when manually positioned open. The distance between the two marks should be approximately the stem travel shown in stem travel chart. (See "Freedom of Movement Check" section.) If the stroke is different than that shown, there is a good reason to believe something is mechanically restricting the stroke of the valve. The cover must be removed, the obstruction located and removed. (See "Maintenance" Section for procedure.)

Due to the weight of the diaphragm assembly this procedure is not possible on valves 8" and larger. on these valves, the same determination can be made by carefully introducing a low pressure-less than five psi) into the valve body with the cover vented. **SEE CAUTION.** Looking in cover center hole see the diaphragm assembly lift easily without hesitation, and then settle back easily when the pressure is removed.

2. To check the valve for drip-tight closure, a line should be connected from the inlet to the cover, and pressure applied at the inlet of the valve. If properly assembled, the valve should hold tight with as low as ten PSI at the inlet. See "Tight Sealing Check" section.)

3. With the line connected from the inlet to the cover, apply full working pressure to the inlet. Check all around the cover for any leaks. Re-tighten cover nuts if necessary to stop leaks past the diaphragm.

4. Remove pressure, then re-install the pilot system and tubing exactly as it was prior to removal. **Bleed air from all high points.**

5. Follow steps under "Start-Up and Adjustment" Section in Technical Manual for returning complete valve back to service.

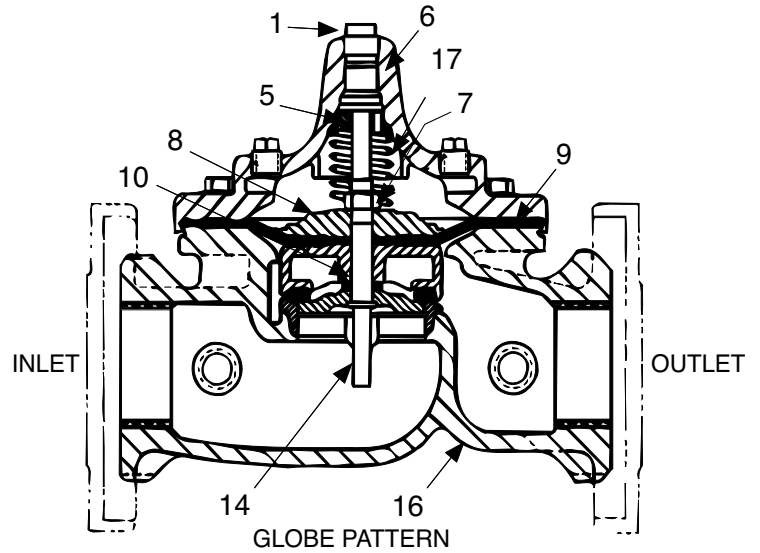
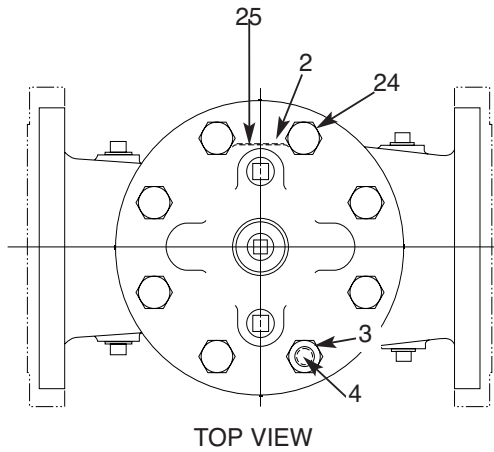

PARTS LIST

Item	Description
1.	Pipe Plug
2.	Drive Screws (for nameplate)
3.	Hex Nut (8" and larger)
4.	Stud (8" and larger)
5.	Cover Bearing
6.	Cover
7.	Stem Nut
8.	Diaphragm Washer
9.	Diaphragm
10.	Spacer Washers
11.	Disc Guide
12.	Disc Retainer
13.	Disc
14.	Stem
15.	Seat
16.	Body
17.	Spring
22.	Flat Head Screws (8" and larger)
23.	Seat O-Ring
24.	Hex head Bolt (1 1/4" thru 4")
25.	Nameplate
26.	Upper Spring Washer (Epoxy coated valves only)
27.	Lower Spring Washer (Epoxy coated valves only)
28.	Cover Bearing Housing (16" only)
29.	Cover O-Ring (16" only)
30.	Hex Bolt (16" only)
31.	Pipe Cap (16" only)

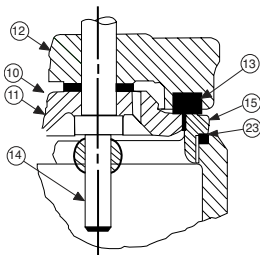
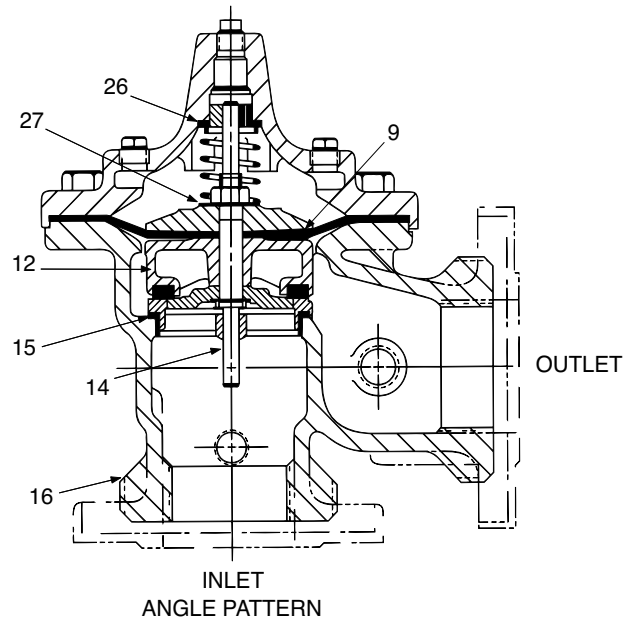

1 1/4" - 6" SEAT DETAIL

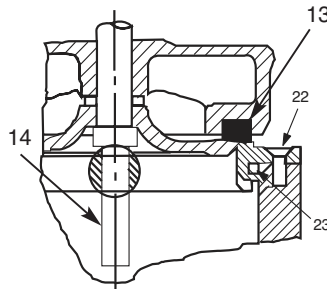

8" - 24" SEAT DETAIL

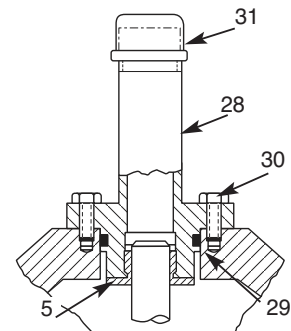

16" COVER DETAIL



— MODEL — **100-01**

Hytrol Valve Service Data

Description 100-01 Hytrol Valve

The Cla-Val Model 100-01 Hytrol Valve is a main valve for Cla-Val Automatic Control Valves. It is a hydraulically operated, diaphragm-actuated, globe or angle pattern valve.

This valve consists of three major components; body, diaphragm assembly, and cover. The diaphragm assembly is the only moving part. The diaphragm assembly uses a diaphragm of nylon fabric bonded with synthetic rubber. A synthetic rubber disc, contained on three and one half sides by a disc retainer and disc guide, forms a seal with the valve seat when pressure is applied above the diaphragm. The diaphragm assembly forms a sealed chamber in the upper portion of the valve, separating operating pressure from line pressure.

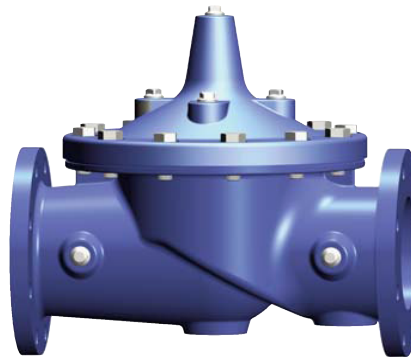

Description 100-20 600 Series Hytrol Valve

The Cla-Val Model 100-20 Hytrol Valve (600 Series main valve) have only one part -the body- that is different from standard 100 Series Cla-Val main valve parts. The remaining parts of the 600 series main valve are standard Cla-Val main valve parts.

All service and maintenance information for the standard 100 Series main valves also apply to the 600 series main valves. The most important thing to remember when ordering main valve repair kits and replacement parts, except for the body, all other parts are going to be for a smaller size main valve. Cla-Val identifies main valve parts with the flange size of the standard 100 Series main valve. Refer to the "Main Valve Sizes" chart below.

HYTROL Service Data

HYTROL SIZE				Stem Travel		Cover Capacity Displacement		Valve Stem Thread UNF-Internal	Cover Center Plug NPT	Cover Nut or Bolt			Cover Lifting Holes UNC	Cover Plug		Cover Torque		Stem Nut **		Stem Nut Torque (ft Lbs)	
100-01	100-20			inches	mm	Gallons	Liters			Thread (Bolt)	Socket	Qty		Thread	Socket	ft. Lbs.	in. Lbs.	Thread	Socket (Long)	Lubed	DRY
inches	mm	inches	mm	inches	mm																
1"	25			0.3	8				1/4"	1/4" - 20 (B)	7/16"	8			4	48	3/8" - 24		4	6	
1 1/4"	32			0.4	10	0.020	0.07	10-32	1/4"	5/16" - 18 (B)	1/2"	8			8	96	7/16" 20		6	10	
1 1/2"	40			0.4	10	0.020	0.07	10-32	1/4"	5/16" - 18 (B)	1/2"	8			8	96	7/16" 20		6	10	
2"	50			0.6	15	0.032	0.12	10-32	1/2"	3/8" - 16 (B)	9/16"	8	3/8"	7/16"	12		1/2" - 20	3/4"	10	15	
2 1/2"	65			0.7	18	0.043	0.16	10-32	1/2"	7/16" - 14 (B)	5/8"	8	1/2"	9/16"	20		5/8" - 18	15/16"	21	30	
3"	80	4"	100	0.8	20	0.080	0.30	1/4 - 28	1/2"	1/2" - 13 (B)	3/4"	8	1/2"	9/16"	30		5/8" - 18	15/16"	21	30	
4"	100	6"	150	1.1	23	0.169	0.64	1/4 - 28	3/4"	3/4" - 10 (B)	1 1/8"	8	3/4"	5/8"	110		3/4" - 16	1 1/16"	40	60	
6"	150	8"	200	1.7	43	0.531	2.00	3/8 - 24	3/4"	3/4" - 10 (B)	1 1/8"	12	3/4"	5/8"	110		7/8" - 14	1 5/16"	85	125	
8"	200	10"	250	2.3	58	1.26	4.80	3/8 - 24	1"	3/4" - 10	1 1/4"	16	5/8" - 11	1"	13/16"	110		1 1/8" - 12	1 13/16"	125	185
10"	250	12"	300	2.8	71	2.51	9.50	3/8 - 24	1"	7/8" - 9	1 7/16"	20	3/4" - 10	1"	13/16"	160		1 1/2" - 12	1 7/8"	250	375
12"	300	16"	400	3.4	86	4.0	15.10	3/8 - 24	1 1/4"	1-1/8" - 7	1 13/16"	20	3/4" - 10	1"	13/16"	390		1 1/2" - 12	2 1/2"	270	400
14"	350			3.9	99	6.5	24.60	3/8 - 24	1 1/2"	1-1/4" - 7	2"	20	1" - 8	1"	13/16"	545		1 1/2" - 12	2 1/2"	280	420
16"	400	20",24"	600	4.5	114	9.5	36.20	1/2 - 20	2"	1-1/4" - 7	2"	20	1" - 8	1"	13/16"	545		2" - 16	3"	500	750
24"	600			6.5	165	29.0	108.80	3/4 - 16 *	3/4"	1-1/2" - 12	2 3/8"	24	1-1/8" 7	1"	13/16"	800		3" - 12	Special	1350	N/R
									* Adapter p/n 2594101E inside 1/4" - 28			Grade 5 Bolts "Heavy" Grade Nuts Tighten cover nuts in a "star" cross-over pattern				**Must Use ONLY Cla-Val Supplied part					

100-01 Hytrol Main Valve Assembly

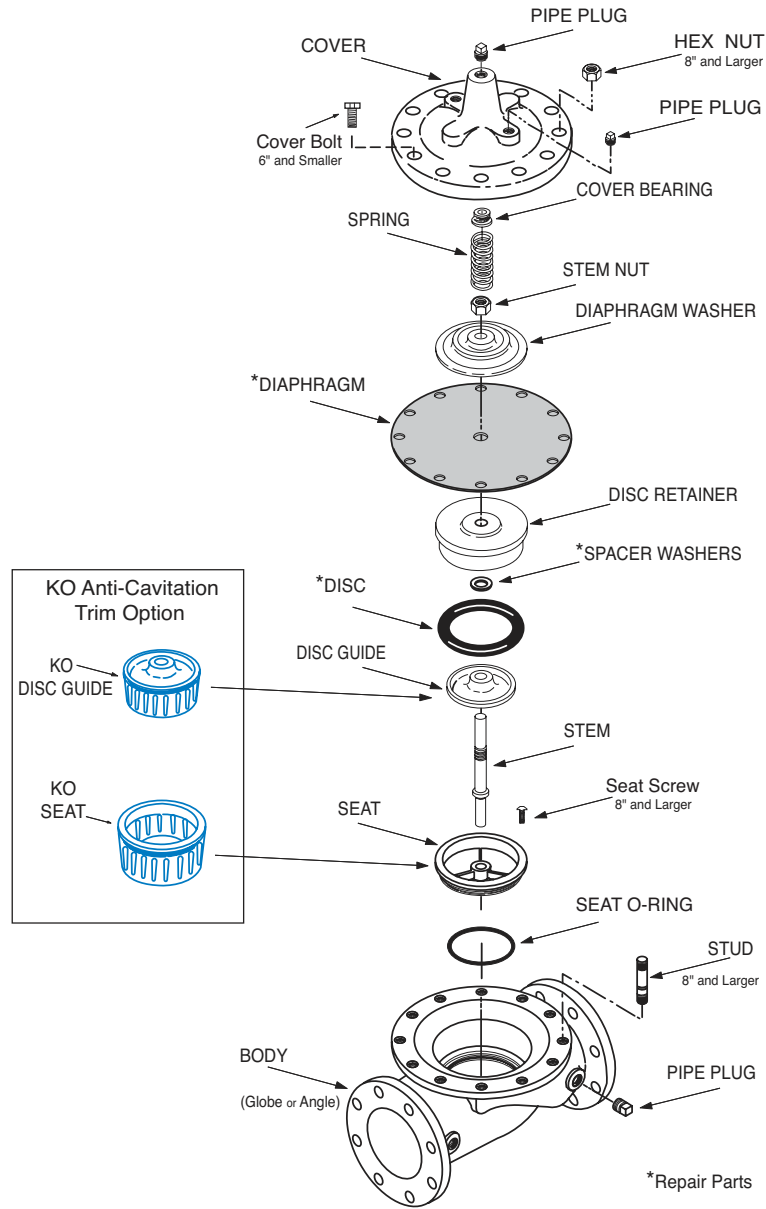

BOLT/NUT TORQUING PROCEDURES ON VALVE COVERS

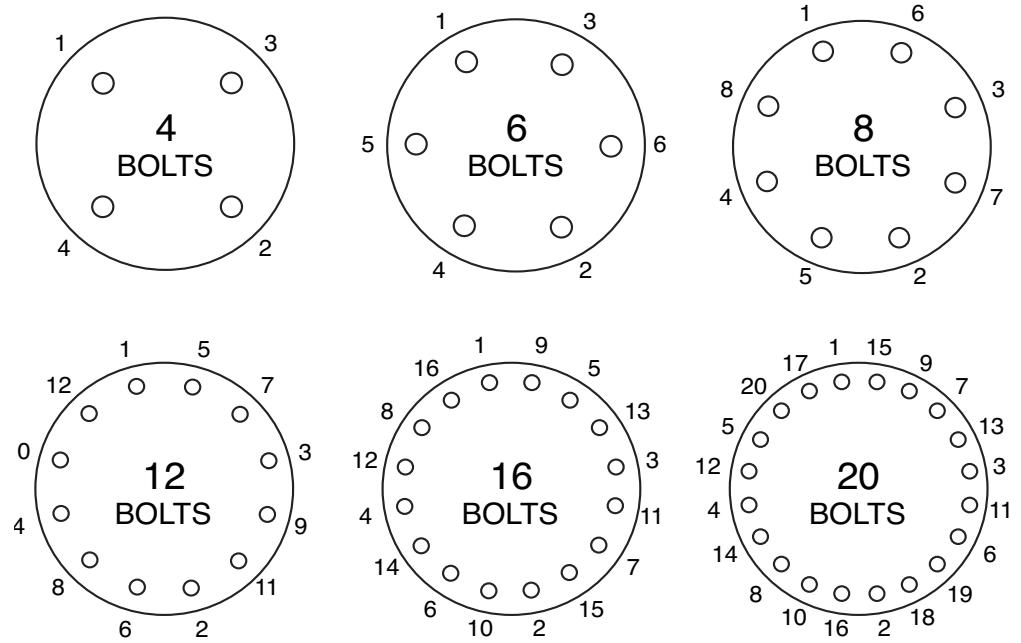

Follow this procedure when reassembling MAIN Valve:

1. Tightens bolts/nuts in a “Star” or “Cross-Over” Pattern following the numbers shown above to insure that cover seats evenly on the diaphragm material and body.
2. Torque the bolt/nuts in three stages:
 - A. To approximately 10% of final torque valve.
 - B. To approximately 75% of final torque valve.
 - C. To final required torque valve.
3. Valves that are to be tested to 375 PSI or higher should be retorqued after 24 hours.



— MODEL — **100-20**
(Reduced Internal Port)

600 Series Hytrol Valve

SERVICE AND MAINTENANCE OF 600 SERIES VALVES

The 600 series main valves have only one part -the body- that is different from standard 100 Series Cla-Val main valve parts. The remaining parts of the 600 series main valve are standard Cla-Val main valve parts. All service and maintenance information for the standard 100 Series main valves in this manual also apply to the 600 series main valves.

The most important thing to remember when ordering main valve repair kits and replacement parts, except for the body, all other parts are going to be for a smaller size main valve. Cla-Val identifies main valve parts with the flange size of the standard 100 Series main valve. Refer to the "Main Valve Sizes Comparison" chart. For example, if you are servicing a 6" 100-20 Hytrol and needed a repair kit, you would order a repair kit for a 4" 100-01 Hytrol. This kit is also suitable for a 6" 100-20 Hytrol. Complete Technical Manuals include a repair kit data sheet N-RK that shows this relationship.

When you order repair parts, it is a good idea to include valve nameplate data (size, catalog number, and part number) and description of the parts desired. Do this to be sure parts will fit the valve you are working on and not be too big for it. Pilot controls and repair kits maintenance information remain the same for 100 or 600 Series valves.

UNDERSTANDING THE 600 SERIES VALVES

In 1987, Cla-Val introduced the Model 100-20 Hytrol as the basic main valve for the 600 Series of automatic control valves. To identify all new valves using the 100-20 Hytrol, an existing catalog number is modified. Making a 600 Series catalog number is simply done by using a "6" in front of the two digit catalog numbers or replacing the "2" with a "6" in three digit catalog numbers. Current schematics reflect both catalog numbers together separated by a slash (i.e. - 90-01/690-01, 58-02/658-02, 210-01/610-01, etc). Since these two valves 'share' the same catalog number and schematic, they provide the same function in a system. The only difference between the two valves is the relative capacity of the two main valve series.

The 100-01 Hytrol is the basic main valve for Cla-Val automatic control valves. This valve is the current version of the Clayton Hytrol valve design originated in 1936. The 100-01 Hytrol is designed as a full flow area valve. This means that the inlet, seat and outlet openings are the same size. Thus, the pressure drop is kept to a minimum for this globe style design.

The 100-20 Hytrol valve has all of the basic features and advantages of the original 100-01 Hytrol. Only one part has been changed - the body. It is designed with different size inlet, seat and outlet openings. The 100-20 Hytrol has inlet and outlet flanges one valve size larger than the seat opening size. This results in what is sometimes called a "reduced port" main valve. For example, a 4" 100-20 valve has a 3" seat. Note: valve size is always determined by the flange size. The following chart compares the 100-01 and the 100-20 main valves.

Basic Main Valve Size Comparison		
Globe Pattern Valves		
Flange Size (inch)	Seat Size	
	100-01 (100 Series)	100-20 (600 Series)
3	3	2
4	4	3
6	6	4
8	8	6
10	10	8
12	12	10
14	14	----
16	16	12
20	----	16
24	24	16
30	30	24
36	36	30
42	----	36
48	----	36
Angle Pattern Valves		
Flange Size (inch)	Seat Size	
	100-01 (100 Series)	100-20 (600 Series)
4	4	3
6	6	4
8	8	6

The 100-20 Hytrol is available only in ductile iron, 150 and 300 pressure class, and Bronze trim standard. Available extra cost main valve options include stainless steel trim, epoxy coating, Dura-Kleen stem, Delrin sleeved stem, and high temperature rubber parts. All four basic main valves have a 600 Series version available with all of the same benefits and size relationships. The following chart shows the relationship of Cla-Val main valve catalog numbers.

Cla-Val Main Valves

Catalog Name	Catalog Number		
	Circa 1936	100-Series	600 Series
Hytrol	100 (Angle =2100)	100-01	100-20
Powertrol	100P & 100PA	100-02	100-21
Powercheck	100PC & 100PCA	100-03	100-22
Hycheck	181	100-04	100-23

100-20

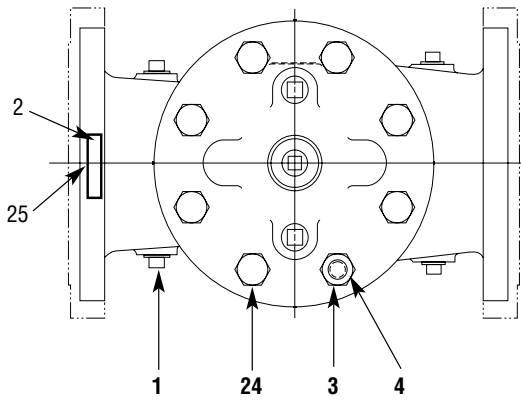

TOP VIEW

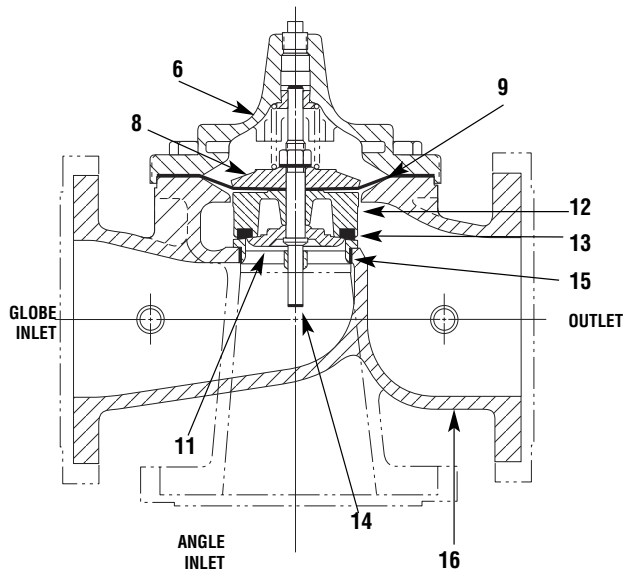

ANGLE INLET

OUTLET

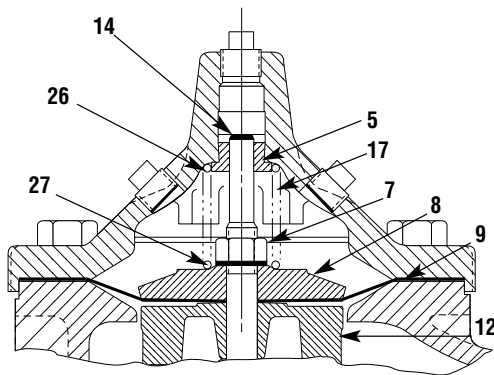

3" - 6" COVER DETAIL

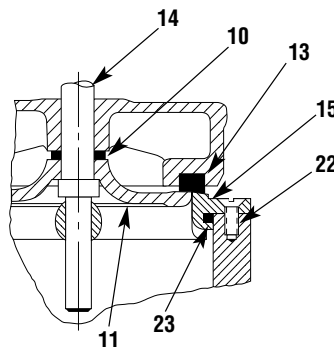

10" - 24" SEAT DETAIL

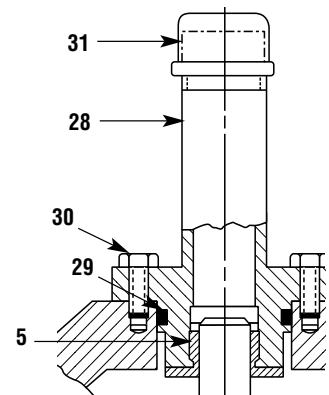

20" - 24" COVER DETAIL

PARTS LIST

NO. DESCRIPTION

- 1 Pipe Plug
- 2 Drive Screws (for nameplate)
- 3 Hex Nut (8" and larger)
- 4 Stud (8" and larger)
- 5 Cover Bearing
- 6 Cover
- 7 Stem Nut
- 8 Diaphragm Washer
- 9 Diaphragm
- 10 Spacer Washers
- 11 Disc Guide
- 12 Disc Retainer
- 13 Disc
- 14 Stem
- 15 Seat
- 16 Body
- 17 Spring
- 22 Flat Head Screws (10" and larger)
- 23 Seat O-Ring
- 24 Hex Bolt (3" Thru 6")
- 25 Nameplate (Mounted on inlet flange)
- 26 Upper Spring Washer (Epoxy coated valves only)
- 27 Lower Spring Washer (Epoxy coated valves only)
- 28 Cover Bearing Housing (20" & 24" & 30")
- 29 Cover Bearing Housing O-Ring (20" & 24" & 30")
- 30 Hex Bolt (20" & 24")
- 31 Pipe Cap (20" & 24" & 30")

WHEN ORDERING PARTS, BE SURE TO GIVE COMPLETE NAMEPLATE DATA, ITEM NUMBER AND DESCRIPTION.



X42N-2

Strainer and Needle Valve Assembly

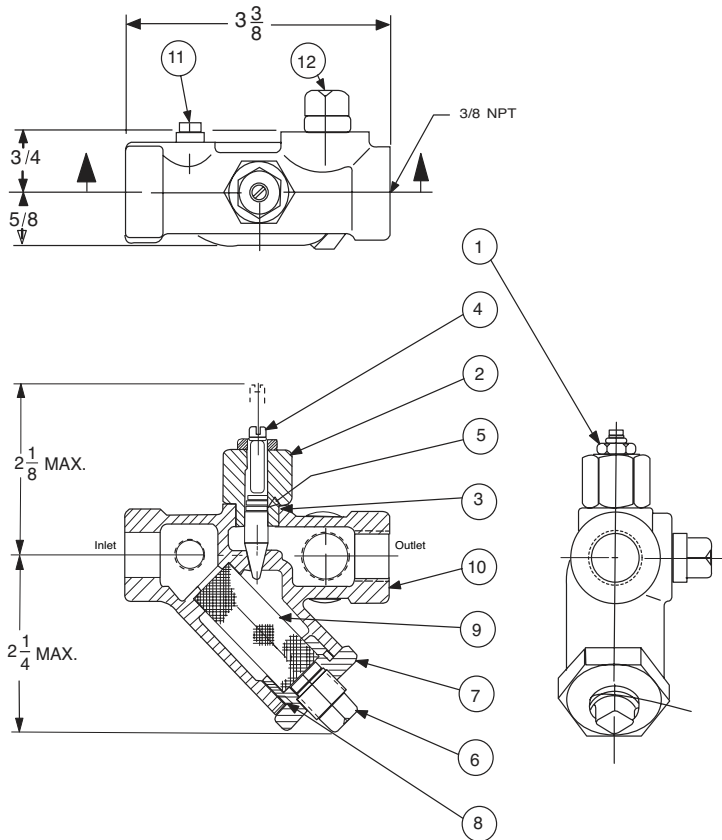

**When ordering parts,
please specify:**

- All nameplate data
- Item Number
- Description

Size	Stock Number
3/8" x 3/8"	68372C

ITEM	DESCRIPTION	MATERIAL	PART NO.
1	Jam Nut —Hex	Sil Brz	6779806G
2	Bonnet	S.S.	67910A
3	"O" Ring—Bonnet	Syn Rub	00713J
4	Stem	S.S.	67907G
5	"O" Ring—Stem	Syn Rub	00708J
6	Plug—Pipe 1/4	Bre.	6784702A
7	Strainer Plug	303	67911J
8	"O" Ring—Plug	NBR	00715J
9	Screen	Monel	68373A
10	Body	Rd Brs	67905A
11	Plug—Pipe 1/8	Brass	6784701C
12	Plug—Pipe 3/8	Brass	67660-03F

This drawing is the property of CIA-VAL CO. and parts and accessories thereof, if any, shall be returned to CIA-VAL CO. upon completion of the work. This drawing shall not be used, copied or reproduced, in whole or in part, for any purpose, without the written authority of CIA-VAL CO. The manufacturer of any equipment or component used in this drawing shall be held responsible for its proper use. CIA-VAL CO. makes no warranty, expressed or implied, for the use of this drawing or for the equipment or component used in this drawing, except as may be indicated by the manufacturer of such equipment or component. CIA-VAL CO.

TRUE LOCATION OF SENSING CONNECTION

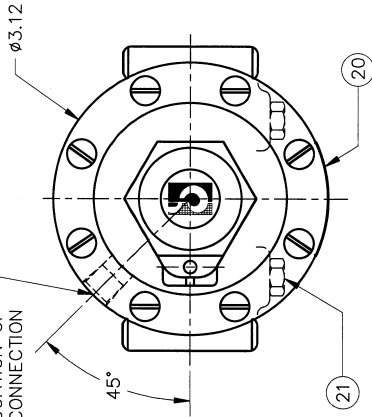

CDB-7 RANGE PSI	APPROXIMATE INCREASE FOR EACH CLOCKWISE TURN OF ADJUSTING SCREW, ITEM NO. 1
0-7	0.75 PSI
5-25	4.0 PSI
10-60	12.0 PSI
20-80	14.5 PSI
50-150	29.5 PSI
65-180	44.0 PSI

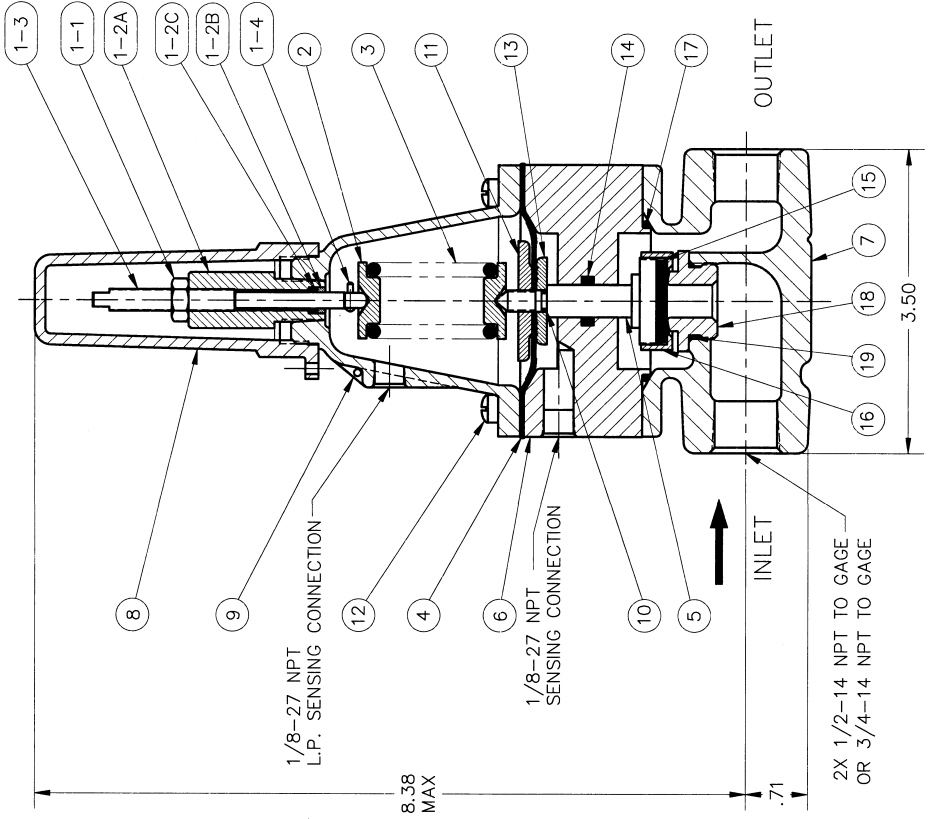

* = RECOMMENDED SPARE PARTS

ITEM NO.	DESCRIPTION	QTY
21	PLUG, PIPE EQ. HD.	2
20	NAMEPLATE	1
19	O-RING	1
18	SEAT	1
17	O-RING	1
16	RETAINER, DISC	1
15	DISC ASSEMBLY	1
14	O-RING	1
13	WASHER, DIAPHRAGM (LOWER)	1
12	SCREW, FIL. HD 10-32 X 1.88 LG	8
11	WASHER, DIAPHRAGM (UPPER)	1
10	O-RING	1
9	COVER	1
8	CAP	1
7	BODY	1
6	BODY, POWERUNIT	1
5	STEM	1
4	DIAPHRAGM	1
3	SPRING	1
2	GUIDE, SPRING	2
1-4	PIN, GROOVE	1
1-3	STEM, ADJUSTING	1
1-2C	O-RING	1
1-2B	INSERT, STUFFING BOX	1
1-2A	HOUSING, STUFFING BOX	1
1-2	BOX ASSEMBLY, STUFFING	1
1-1	NUT, HEX	1
1	X102A ADJUSTING STEM ASSEMBLY	1

UNLESS OTHERWISE SPECIFIED DIMENSIONS ARE IN INCHES FRACTIONS DECIMALS ANGULAR
 1/32 0.03125 0.0001
 1/16 0.0625 0.0002
 1/8 0.125 0.0004
 3/16 0.1875 0.0006
 1/4 0.25 0.0008
 5/16 0.3125 0.0010
 3/8 0.375 0.0012
 1/2 0.5 0.0015
 5/8 0.625 0.0018
 3/4 0.75 0.0020
 7/8 0.875 0.0025
 1 1.0 0.0030
 SURFACE FINISH: 125
 BREAK CORNERS: 0.015 MAX
 ---001 NOT SCALE DRAWING---

CONTRACT NO.	DATE	APPROVALS	DATE	APPROVED
	2-23-84	MGR	2-23-84	MGR
	4-6-84	KD	4-6-84	AK
	4-17-84	CH	4-17-84	AK
		ENGR		

ITEM NO.	DESCRIPTION	QTY
21	PLUG, PIPE EQ. HD.	2
20	NAMEPLATE	1
19	O-RING	1
18	SEAT	1
17	O-RING	1
16	RETAINER, DISC	1
15	DISC ASSEMBLY	1
14	O-RING	1
13	WASHER, DIAPHRAGM (LOWER)	1
12	SCREW, FIL. HD 10-32 X 1.88 LG	8
11	WASHER, DIAPHRAGM (UPPER)	1
10	O-RING	1
9	COVER	1
8	CAP	1
7	BODY	1
6	BODY, POWERUNIT	1
5	STEM	1
4	DIAPHRAGM	1
3	SPRING	1
2	GUIDE, SPRING	2
1-4	PIN, GROOVE	1
1-3	STEM, ADJUSTING	1
1-2C	O-RING	1
1-2B	INSERT, STUFFING BOX	1
1-2A	HOUSING, STUFFING BOX	1
1-2	BOX ASSEMBLY, STUFFING	1
1-1	NUT, HEX	1
1	X102A ADJUSTING STEM ASSEMBLY	1

CONTRACT NO.	DATE	APPROVALS	DATE	APPROVED
	2-23-84	MGR	2-23-84	MGR
	4-6-84	KD	4-6-84	AK
	4-17-84	CH	4-17-84	AK
		ENGR		

ITEM NO.	DESCRIPTION	QTY
21	PLUG, PIPE EQ. HD.	2
20	NAMEPLATE	1
19	O-RING	1
18	SEAT	1
17	O-RING	1
16	RETAINER, DISC	1
15	DISC ASSEMBLY	1
14	O-RING	1
13	WASHER, DIAPHRAGM (LOWER)	1
12	SCREW, FIL. HD 10-32 X 1.88 LG	8
11	WASHER, DIAPHRAGM (UPPER)	1
10	O-RING	1
9	COVER	1
8	CAP	1
7	BODY	1
6	BODY, POWERUNIT	1
5	STEM	1
4	DIAPHRAGM	1
3	SPRING	1
2	GUIDE, SPRING	2
1-4	PIN, GROOVE	1
1-3	STEM, ADJUSTING	1
1-2C	O-RING	1
1-2B	INSERT, STUFFING BOX	1
1-2A	HOUSING, STUFFING BOX	1
1-2	BOX ASSEMBLY, STUFFING	1
1-1	NUT, HEX	1
1	X102A ADJUSTING STEM ASSEMBLY	1

SCALE 1/1

SHEET 1 OF 1

VL 1-19-06

DIST. CODE 007A

CIA-VAL CO. NEWPORT BEACH, CALIFORNIA

1/2" & 3/4" CDB-7 DIFFERENTIAL CONTROL

DWG NO. 93089

REV B

DWG NO. 93089



Regulator Spring Color Coding Chart

Dwg#47117

*THESE FIGURES ARE ONLY APPROXIMATE. FINAL ADJUSTMENTS SHOULD BE MADE WITH A PRESSURE GAGE.

WIRE SIZE	SPRING NUMBER	COLOR	WIRE MATERIAL	CATALOG NUMBER	PSI RANGE	*PSI PER TURN
.080 DIA.	C0492D	BLUE	S.S.	CDB-7	0-7	.75
				CRL-5A	0-7	.75
.018 DIA.	82575C	--	S.S.	CRD	1.9-6.5	.61
				CRD-10A	1.9-6.5	.49
.116 DIA.	81594E	--	S.S.	CRD	2-30	3.0
				CRD-10A	2-30	2.4
.120 DIA.	V5654J	GREEN	CHR VAN	CRL-5A	5-25	4.0
				CRD	10-40	4.0
.162 DIA.	32447F	NATURAL	S.S.	CDB-7	10-60	12.0
				CRL-5A	10-60	12.0
				CRL-13	10-60	12.0
.162 DIA.	V5695B	YELLOW	MUSIC WIRE	CDB-7	20-80	14.5
				CRL-5A	20-80	14.5
				CRL-13	20-80	14.5
.207 DIA.	C1124B	CAD PLT	MUSIC WIRE	CDB-7	50-150	29.5
				CRL-13	50-150	29.5
				CRL-5A	50-150	29.5
.225 DIA.	V6515A	RED	MUSIC WIRE	CDB-7	65-180	44.0
				CRL-13	65-180	44.0
				CRL-5A	65-180	44.0
.115 X .218	71884B	RED	CHR VAN	CRL	0-75	8.5
				CRD	15-75	9.0
				CRD-10A	15-75	7.2
.118 X .225	71885J	GREEN	CHR VAN	CRL	20-200	28.0
				CRD	30-300	27.0
				CRD-10A	30-300	22.4
.225 X .295	1630201A	CAD PLT	CHR VAN	CRL	100-300	18.00
				CRL-5A	100-300	18.00
.440 X .219	48211H	CAD PLT	STEEL	CRA-18	200-450	17.0
				CRD-22	200-450	17.0
				CRL-4A	100-450	17.0
.187	20632101E	BLACK	316 SST	CRD	20-105	13.0
				CRL	20-105	13.0
WIRE SIZE	SPRING NUMBER	COLOR	WIRE MATERIAL	CATALOG NUMBER	PSI RANGE	*FEET PER TURN
.080 DIA.	C0492D	BLUE	S.S.	CRA	4.5-15	.82
				CRD-2	4.5-15	.82
.375 DIA.	87719B	EPOXY COATED	CHROME SILICON	CDS-5	5-40	1.0
	1 SPRING			30-80	2.0	
	2 SPRING			70-120	3.0	
	3 SPRING			110-120	4.0	
	4 SPRING			150-200	5.0	
.072 DIA.	V5097A	--	302SS	CVC	1-17	.7
.375 DIA.	2933502H	EPOXY COATED	CHROME SILICON	CDS-6A	5-40	.75
	1 SPRING			30-80	1.50	
	2 SPRING			70-120	2.20	
	3 SPRING			110-160	3.00	
	4 SPRING			150-200	3.70	

THE FOLLOWING CONTROL & SPRING P/N#S WERE REMOVED, 32656B, 31554K, 44591G, V65695B, & V5695B. ADDED CRL-13, CRL-5A, CRA, CRA-10A, CHANGED SPRING RANGES TO MATCH CURRENT CONTROLS.

*This drawing is the property of CLA-VAL and same and copies made thereof, if any, shall be returned to it upon demand. Delivery and disclosure hereof are made solely upon condition that the same shall not be used, copied or reproduced, nor shall the subject here of be disclosed in any manner to anyone for any purpose, except as herein authorized, without prior approval of CLA-VAL. Whether or not the equipment or information shown hereon is patented or otherwise protected, full title and copyrights if any, in and to this drawing and/or information delivered or submitted are fully reserved by CLA-VAL.

CLA-VAL CO. NEWPORT BEACH, CALIFORNIA	CATALOG NO.	DRAWING NO. 67783	REV BA
	TYPE OF VALVE AND MAIN FEATURES <h2 style="margin: 0;">CK2 COCK/BALL VALVE</h2>		DESIGN DRAWN MGR 4-02-80 CHK'D KD 4-03-80 APVD CH 4-07-80

SCALE: NONE

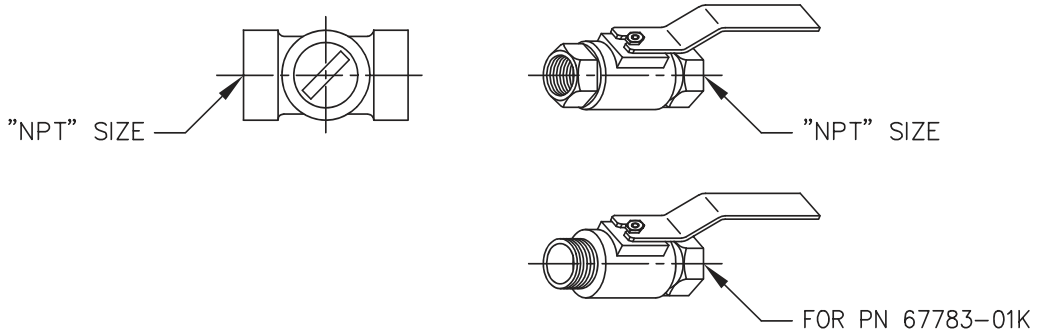

CLA-VAL PART NO. AND MATERIAL

BRONZE WITH HANDLE	STEEL WITH HANDLE	IRON WITH HANDLE	316 SST WITH HANDLE	316 SST W/ LOCKING HANDLE	BRONZE WITH HANDLE	MONEL WITH HANDLE	SIZE "NPT"
67783-01K*	-09C	-17F	-25J SUPSD BY-26G		-41F SUPSD BY-01K		1/8"
-02H	-10A	-18D	-26G	-51E SUPSD BY-26G -52C	-42D SUPSD BY-02H	-55F	1/4"
-03F* -59H***	-11J	-19B	-27E	-46E SUPSD BY-27E -53A	-45G -57B**	-48A SUPSD BY-49J	3/8"
-04D -60F***	-12G	-20K	-28C	-54J	-43B SUPSD BY-04D	-49J	1/2"
-05A -61D***	-13E	-21H	-29A		-44K SUPSD BY-05A	-56D	3/4"
-06J	-14C	-22F	-30J			-58K	1"
-07G	-15K	-23D	-31G				1 1/4"
-08E	-16H	-24B	-32E				1 1/2"
-50G			-47C				2"

- * SEE ENGINEERING APPROVED VENDORS TABLE (SHEET 2 OF 2).
- ** HAMMOND VALVE 8501 ONLY.
- *** WILKINS CK2 (SEE SHEET 2 OF 2)

CAD REVISION RECORD — DO NOT REVISE MANUALLY

LTR	BY	DATE	DESCRIPTION
BA	AK	03-14-06	A-AY SEE REVISION FILE BA ADDED P/N'S 67783-59H, 67783-60F & 67783-61D (ECO 20434)

"THIS DRAWING IS THE PROPERTY OF CLA-VAL CO. AND SAME AND COPIES MADE THEREOF, IF ANY, SHALL BE RETURNED TO IT UPON DEMAND. DELIVERY AND DISCLOSURE HEREOF ARE SOLELY UPON CONDITION THAT THE SAME SHALL NOT BE USED, COPIED OR REPRODUCED, NOR SHALL THE SUBJECT HEREOF BE DISCLOSED IN ANY MANNER TO ANYONE FOR ANY PURPOSE, EXCEPT AS HEREIN AUTHORIZED, WITHOUT PRIOR WRITTEN APPROVAL OF CLA-VAL CO. THIS DRAWING IS SUBMITTED CONFIDENTIALLY AND MAY NOT BE USED IN THE MANUFACTURE OF ANY MATERIAL OR PRODUCT OTHER THAN SUCH MATERIALS AND PRODUCTS FURNISHED TO CLA-VAL CO. WHETHER OR NOT THE EQUIPMENT OR INFORMATION SHOWN HEREON IS PATENTED OR OTHERWISE PROTECTED, FULL TITLE AND COPYRIGHTS, IF ANY, IN AND TO THIS DRAWING AND/OR INFORMATION DELIVERED OR SUBMITTED ARE FULLY RESERVED CLA-VAL CO."



CDC-1 Check Valve

ITEM	DESCRIPTION
1	Retainer, Seal
2	O-Ring
3	Retainer, Valve
4	Seal, Valve Ring
5	Plate Valve

SIZE (NTP)	STOCK NUMBER	A (inch)	B HEX (inch)
3/8	9834501A	2.06	1.06
1/2	9834502J	2.12	1.38

Material: Bronze

Available only in replacement assembly.

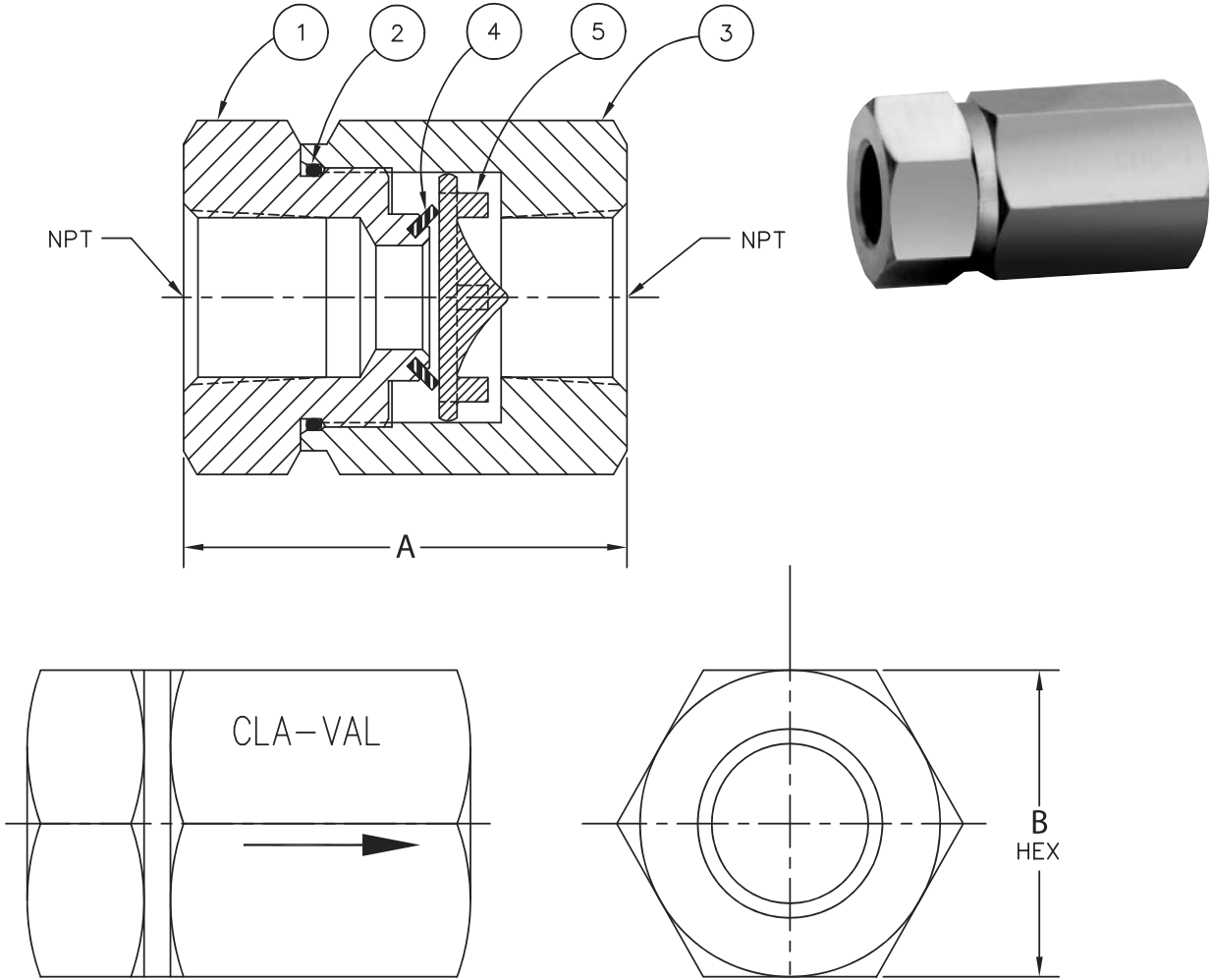



— MODEL — **CV**
Flow Control



DESCRIPTION

The Cla-Val Model CV Flow Control is a simply-designed, spring-loaded check valve. Rate of flow is full flow in one direction and restricted in other direction. Flow is adjustable in the restricted direction. It is intended for use in conjunction with a pilot control system on a Cla-Val Automatic Control Valve.

OPERATION

The CV Flow Control permits full flow from port A to B, and restricted flow in the reverse direction. Flow from port A to B lifts the disc from seat, permitting full flow. Flow in the reverse direction seats the disc, causing fluid to pass through the clearance between the stem and the disc. This clearance can be increased, thereby increasing the restricted flow, by screwing the stem out, or counter-clockwise. Turning the stem in, or clockwise reduces the clearance between the stem and the disc, thereby reducing the restricted flow.'

INSTALLATION

Install the CV Flow Control as shown in the valve schematic. All connections must be tight to prevent leakage.

DISASSEMBLY

Follow the sequence of the item numbers assigned to the parts in the cross sectional illustration for recommended order of disassembly.

Use a scribe, or similar sharp-pointed tool to remove O-ring from the stem.

INSPECTION

Inspect all threads for damage or evidence of cross-threading. Check mating surface of seat and valve disc for excessive scoring or embedded foreign particles. Check spring for visible distortion, cracks and breaks. Inspect all parts for damage, corrosion and cleanliness.

CLEANING

After disassembly and inspection, cleaning of the parts can begin. Water service usually will produce mineral or lime deposits on metal parts in contact with water. These deposits can be cleaned by dipping the parts in a 5-percent muriatic acid solution just long enough for deposits to dissolve. This will remove most of the common types of deposits. **Caution: use extreme care when handling acid.** If the deposit is not removed by acid, then a fine grit (400) wet or dry sandpaper can be used with water. Rinse parts in water before handling. An appropriate solvent can clean parts used in fueling service. Dry with compressed air or a clean, lint-free cloth. Protect from damage and dust until reassembled.

REPAIR AND REPLACEMENT

Minor nicks and scratches may be polished out using a fine grade of emery or crocus cloth; replace parts if scratches cannot be removed.

Replace O-ring packing and gasket each time CV Flow Control is overhauled.

Replace all parts which are defective. Replace any parts which create the slightest doubt that they will not afford completely satisfactory operation. Use Inspection steps as a guide.

REASSEMBLY

Reassembly is the reverse of disassembly; no special tools are required.

TEST PROCEDURE

No testing of the flow Control is required prior to reassembly to the pilot control system on Cla-Val Main Valve.



CV 3/8" Flow Control

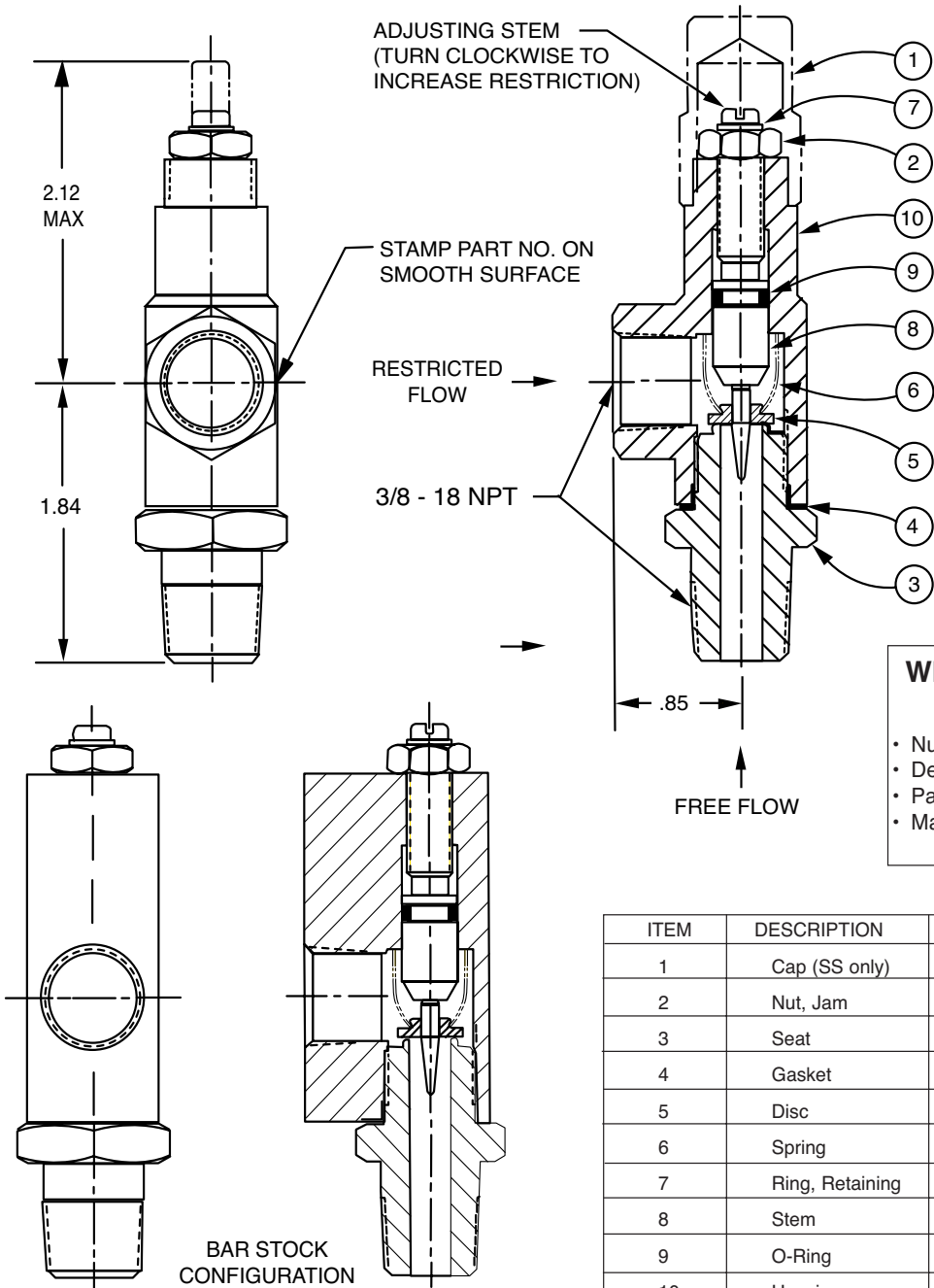

When ordering parts, please specify:

- Number Stamped on Side
- Description (CV Flow Control)
- Part Description
- Material

ITEM	DESCRIPTION	QTY
1	Cap (SS only)	1
2	Nut, Jam	1
3	Seat	1
4	Gasket	1
5	Disc	1
6	Spring	1
7	Ring, Retaining	1
8	Stem	1
9	O-Ring	1
10	Housing	1



Cla-Val Product Identification

How to Order

Proper Identification

For ordering repair kits, replacement parts, or for inquiries concerning valve operation, it is important to properly identify Cla-Val products already in service by including all nameplate data with your inquiry. Pertinent product data includes valve function, size, material, pressure rating, end details, type of pilot controls used and control adjustment ranges.

Identification Plates

For product identification, cast-in body markings are supplemented by identification plates as illustrated on this page. The plates, depending on type and size of product, are mounted in the most practical position. **It is extremely important that these identification plates are not painted over, removed, or in any other way rendered illegible.**

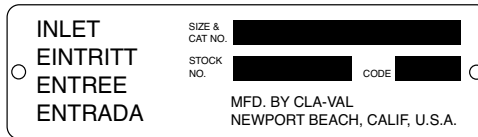

This brass plate appears on valves sized 2 1/2" and larger and is located on the top of the inlet flange.

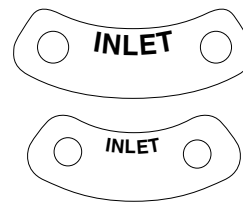

These two brass plates appear on 3/8", 1/2", and 3/4" size valves and are located on the valve cover.



This brass plate appears on altitude valves only and is found on top of the outlet flange.

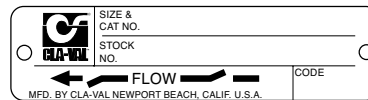

These two brass plates appear on threaded valves 1" through 3" size or flanged valves 1" through 2". It is located on only one side of the valve body.

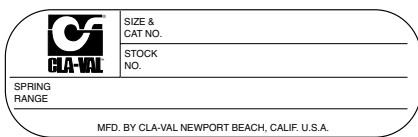

This tag is affixed to the cover of the pilot control valve. The adjustment range appears in the spring range section.

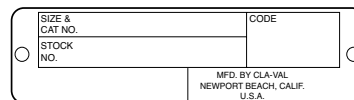

This brass plate is used to identify pilot control valves. The adjustment range is stamped into the plate.

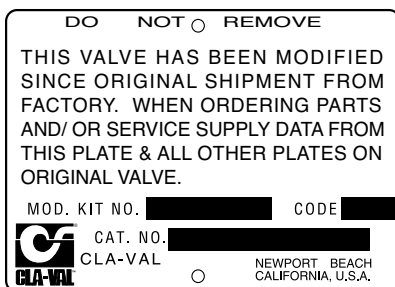

This aluminum plate is included in pilot system modification kits and is to be wired to the new pilot control system after installation.

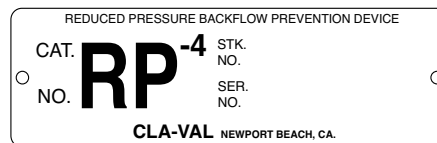

This brass plate is used on our backflow prevention assemblies. It is located on the side of the Number Two check (2" through 10"). The serial number of the assembly is also stamped on the top of the inlet flange of the Number One check.



HOW TO ORDER

Because of the vast number of possible configurations and combinations available, many valves and controls are not shown in published product and price lists. For ordering information, price and availability on product that are not listed, please contact your local Cla-Val office or our factory office located at:

P. O. Box 1325
Newport Beach, California 92659-0325
(949) 722-4800
FAX (949) 548-5441

SPECIFY WHEN ORDERING

- Model Number
- Globe or Angle Pattern
- Adjustment Range (As Applicable)
- Valve Size
- Threaded or Flanged
- Body and Trim Materials
- Optional Features
- Pressure Class

UNLESS OTHERWISE SPECIFIED

- Globe or angle pattern are the same price
- Ductile iron body and bronze trim are standard
- X46 Flow Clean Strainer or X43 "Y" Strainer are included
- CK2 Isolation Valves are included in price on 4" and larger valve sizes (6" and larger on 600 Series)

LIMITED WARRANTY

Automatic valves and controls as manufactured by Cla-Val are warranted for three years from date of shipment against manufacturing defects in material and workmanship that develop in the service for which they are designed, provided the products are installed and used in accordance with all applicable instructions and limitations issued by Cla-Val. Electronic components manufactured by Cla-Val are warranted for one year from the date of shipment.

We will repair or replace defective material, free of charge, that is returned to our factory, transportation charges prepaid, if upon inspection, the material is found to have been defective at time of original shipment. This warranty is expressly conditioned on the purchaser's providing written notification to Cla-Val immediate upon discovery of the defect.

Components used by Cla-Val but manufactured by others, are warranted only to the extent of that manufacturer's guarantee.

This warranty shall not apply if the product has been altered or repaired by others, Cla-Val shall make no allowance or credit for such repairs or alterations unless authorized in writing by Cla-Val.

DISCLAIMER OF WARRANTIES AND LIMITATIONS OF LIABILITY

The foregoing warranty is exclusive and in lieu of all other warranties and representations, whether expressed, implied, oral or written, including but not limited to any implied warranties or merchantability or fitness for a particular purpose. All such other warranties and representations are hereby cancelled.

Cla-Val shall not be liable for any incidental or consequential loss, damage or expense arising directly or indirectly from the use of the product. Cla-Val shall not be liable for any damages or charges for labor or expense in making repairs or adjustments to the product. Cla-Val shall not be liable for any damages or charges sustained in the adaptation or use of its engineering data and services. No representative of Cla-Val may change any of the foregoing or assume any additional liability or responsibility in connection with the product. The liability of Cla-Val is limited to material replacements F.O.B. Newport Beach, California.

TERMS OF SALE

ACCEPTANCE OF ORDERS

All orders are subject to acceptance by our main office at Newport Beach, California.

CREDIT TERMS

Credit terms are net thirty (30) days from date of invoice.

PURCHASE ORDER FORMS

Orders submitted on customer's own purchase order forms will be accepted only with the express understanding that no statements, clauses, or conditions contained in said order form will be binding on the Seller if they in any way modify the Seller's own terms and conditions of sales.

PRODUCT CHANGES

The right is reserved to make changes in pattern, design or materials when deemed necessary, without prior notice.

PRICES

All prices are F.O.B. Newport Beach, California unless expressly stated otherwise on our acknowledgement of the order. Prices are subject to change without notice. The prices at which any order is accepted are subject to adjustment to the Seller's price in effect at the time of shipment. Prices do not include sales, excise, municipal, state or any other Government taxes. Minimum order charge \$75.00.

RESPONSIBILITY

We will not be responsible for delays resulting from strikes, accidents, negligence of carriers, or other causes beyond our control. Also, we will not be liable for any unauthorized product alterations or charges accruing there from.

RISK

All goods are shipped at the risk of the purchaser after they have been delivered by us to the carrier. Claims for error, shortages, etc., must be made upon receipt of goods.

EXPORT SHIPMENTS

Export shipments are subject to an additional charge for export packing.

RETURNED GOODS

1. Customers must obtain written approval from Cla-Val prior to returning any material.
2. Cla-Val reserves the right to refuse the return of any products.
3. Products more than six (6) months old cannot be returned for credit.
4. Specially produced, non-standard models cannot be returned for credit.
5. Rubber goods such as diaphragms, discs, o-rings, etc., cannot be returned for credit, unless as part of an unopened vacuum sealed repair kit which is less than six months old.
6. Goods authorized for return are subject to a 35% (\$75 minimum) restocking charge and a service charge for inspection, reconditioning, replacement of rubber parts, retesting, repainting and repackaging as required.
7. Authorized returned goods must be packaged and shipped prepaid to Cla-Val, 1701 Placentia Avenue, Costa Mesa, California 92627.



CLA-VAL

PO Box 1325 Newport Beach CA 92659-0325
Phone: 949-722-4800 • Fax: 949-548-5441

CLA-VAL CANADA

4687 Christie Drive
Beamsville, Ontario
Canada LOR 1B4
Phone: 905-563-4963
Fax: 905-563-4040

CLA-VAL EUROPE

Chemin des Mesanges 1
CH-1032 Romanel/
Lausanne, Switzerland
Phone: 41-21-643-15-55
Fax: 41-21-643-15-50

©COPYRIGHT CLA-VAL 2007 Printed in USA
Specifications subject to change without notice.

www.cla-val.com

Represented By:



— MODEL — **REPAIR KITS**

Complete Replacement Diaphragm Assemblies for 100-01 and 100-20 Hytrol Main Valves

For: Hytrol Main Valves with Ductile Iron, Bronze Trim Materials—**125/150 Pressure Class Only.**
FACTORY ASSEMBLED

Includes: Stem, Disc Guide, Disc, Disc Retainer, Spacer Washers, Diaphragm, Diaphragm Washer and Stem Nut.

Valve Size	Diaphragm Assembly Stock Number		Valve Size	Diaphragm Assembly Stock Number	
	100-01	100-20		100-01	100-20
3/8" (Also 81-01)	49097K	N/A	6"	40456G	33273E
1/2" - 3/4" (Also 81-01)	C2518D	N/A	8"	45276D	40456G
1"	C2520K	N/A	10"	81752J	45276D
1 1/4"-1 1/2"	C2522 F	N/A	12"	85533J	81752J
2"	C2524B	N/A	14"	89067D	N/A
2 1/2"	C2523D	N/A	16"	89068B	85533J
3"	C2525J	C2524B	20"	N/A	89068B
4"	33273E	C2525J	24"	N/A	89068B

Repair Kits for 100-01/100-20 Hytrol Valves

For: Hytrol Main Valves—**125/150 Pressure Class Only.**

Includes: Diaphragm, Disc (or Disc Assembly) and spare Spacer Washers.

Buna-N® Standard Material				Viton (For KB Valves)			
Valve Size	Repair Kit Stock Number		Valve Size	Repair Kit Stock Number			
	100-01	100-20		100-01	100-20		
3/8" (Also 81-01)	9169801K	N/A	3/8" (Also 81-01)	9169806J	N/A		
1/2" - 3/4" (Also 81-01)	9169802H	N/A	1/2" - 3/4" (Also 81-01)	9169807G	N/A		
1"	9169803F	N/A	1"	9169808E	N/A		
1 1/4" - 1 1/2"	9169804D	N/A	1 1/4" - 1 1/2"	9169809C	N/A		
2"	9169805A	N/A	2"	9169810A	N/A		
2 1/2"	9169811J	N/A	2 1/2"	9169817F	N/A		
3"	9169812G	9169805A	3"	9169818D	9169810A		
4"	9169813E	9169812G	4"	9169819B	9169818D		
6"	9169815K	9169813E	6"	9169820K	9169819B		
8"	9817901D	9169815K	8"	9169834A	9169820K		
10"	9817902B	9817901D					
12"	9817903K	9817902B					
14"	9817904H	N/A					
16"	9817905E	9817903K					
20"	N/A	9817905E					
24"	9817906C	9817905E					

When ordering, please give complete nameplate data of the valve and/or control being repaired.
MINIMUM ORDER CHARGE APPLIES.

Repair Kits for 100-02/100-21 Powertrol and 100-03/100-22 Powercheck Main Valves

For: Powertrol and Powercheck Main Valves—125/150 Pressure Class Only

Includes: Diaphragm, Disc (or Disc Assembly) and O-rings and full set of spare Spacer Washers.

Valve Size	Kit Stock Number 100-02	Valve Size	Kit Stock Number	
			100-02 & 100-03	100-21 & 100-22
3/8"	9169901H	2 1/2"	9169910J	N/A
1/2" & 3/4"	9169902F	3"	9169911G	9169905J
1"	9169903D	4"	9169912E	9169911G
1 1/4" & 1 1/2"	9169904B	6"	9169913C	9169912E
2"	9169905J	8"	99116G	9169913C
		10"	9169939H	99116G
		12"	9169937B	9169939H

Repair Kits for 100-04/100-23 Hy-Check Main Valves

For: Hy-Check Main Valves—125/150 Pressure Class Only

Includes: Diaphragm, Disc and O-Rings and full set of spare Spacer Washers.

Larger Sizes: Consult Factory.

Valve Size	Kit Stock Number		Valve Size	Kit Stock Number	
	100-04	100-23		100-04	100-23
4"	20210901B	N/A	12"	20210905H	20210904J
6"	20210902A	20210901B	14"	20210906G	N/A
8"	20210903K	20210902A	16"	20210907F	20210905H
10"	20210904J	20210903K	20"	N/A	20210907F
			24"	N/A	20210907F

Repair Kits for Pilot Control Valves

Includes: Diaphragm, Disc (or Disc Assembly), O-Rings, Gaskets or spare Screws as appropriate.

Larger Sizes: Consult Factory.

BUNA-N® (Standard Material)				VITON (For KB Control)	
Pilot Control	Kit Stock Number	Pilot Control	Kit Stock Number	Pilot Control	Kit Stock Number
CDB	9170006C	CRM-7	1263901K	CDB-KB	9170012A
CDB-3D	9170023H	CFM-7A	1263901K	CRA-KB	N/A
CDB-3I	9170024F	CFM-9	12223E	CRD-KB (w/bucking spring)	9170008J
CDB-7	9170017K	CRA (w/bucking spring)	9170001D	CRL-KB	9170013J
CDH-2	18225D	CRD (w/bucking spring)	9170002B	CDHS-2BKB	9170010E
CDHS-2	44607A	CRD (no bucking spring)	9170003K	CDHS-2FKB	9170011C
CDHS-2B	9170004H	CRD-18	20275401K	CDHS-18KB (no bucking spring)	9170009G
CDHS-2F	9170005E	CRD-22	98923G	102C-KB	1726202D
CDHS-3C-A2	24657K	CRL (55F, 55L)	9170007A		
CDHS-8A	2666901A	CRL-4A	43413E		
CDHS-18	9170003K	CRL-5 (55B)	65755B		
CDS-4	9170014G	CRL-5A (55G)	20666E		
CDS-5	14200A	CRL-18	20309801C		
CDS-6	20119301A	CV	9170019F		
CDS-6A	20349401C	X105L (O-ring)	00951E	Buna-N®	
CFCM-M1	1222301C	102B-1	1502201F	CRD Disc Ret. (Solid)	C5256H
CFM-2	12223E	102C-2	172601F	CRD Disc Ret. (Spring)	C5255K
		102C-3	172601F		

Repair Assemblies (In Standard Materials Only)

Control	Description	Stock Number
CF1-C1	Pilot Assembly Only	89541H
CF1-CI	Complete Float Control less Ball and Rod	89016A
CFC2-C1	Disc, Distributor and Seals	2674701E
CSM 11-A2-2	Mechanical Parts Assembly	97544B
CSM 11-A2-2	Pilot Assembly Only	18053K
33A 1"	Complete Internal Assembly and Seal	2036030B
33A 2"	Complete Internal Assembly and Seal	2040830J

When ordering, please give complete nameplate data of the valve and/or control being repaired. MINIMUM ORDER CHARGE APPLIES