

CLA-VAL

AUTOMATIC CONTROL VALVES

750-60

Place this manual with personal responsible
for maintenance of this valve

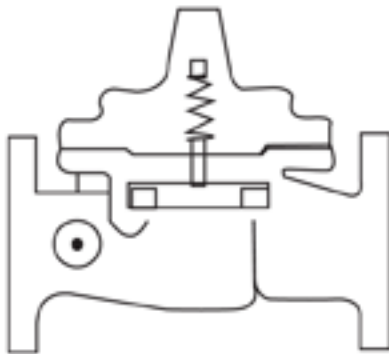

INSTALLATION

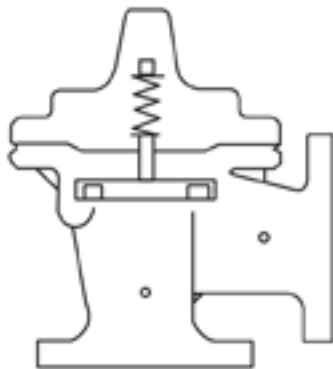

OPERATION

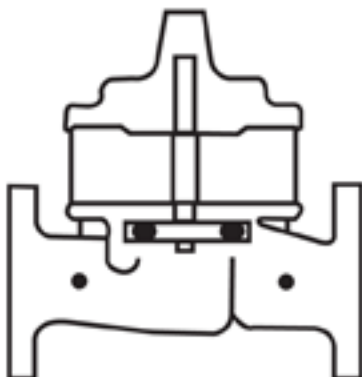

MAINTENANCE



This page was intentionally left blank!

CLA-VAL CO.

NEWPORT BEACH, CALIFORNIA

CATALOG NO.
750-60

DRAWING NO.
200406

REV
B

TYPE OF VALVE AND MAIN FEATURES

**PRESSURE RELIEF VALVE
(FOR FIRE HYDRANT SERVICE)**

DESIGN		
DRAWN	PLF	8-9-98
CHK'D	CH	8-12-98
APVD	BF	8-12-98

3-31-99
 AK
 B REVISED & ADDED OPTIONS B,C & S. (NED 44122)

CAD REVISION RECORD - DO NOT REVISE MANUALLY
 LTR
 - RELEASED FOR PRODUCTION. (NED 43523)
 A ITEM 3 - SHOW BUILT IN RESTRICTOR (ECO 17464)

BY	DATE
PLF	8-9-98
PLF	1-8-99

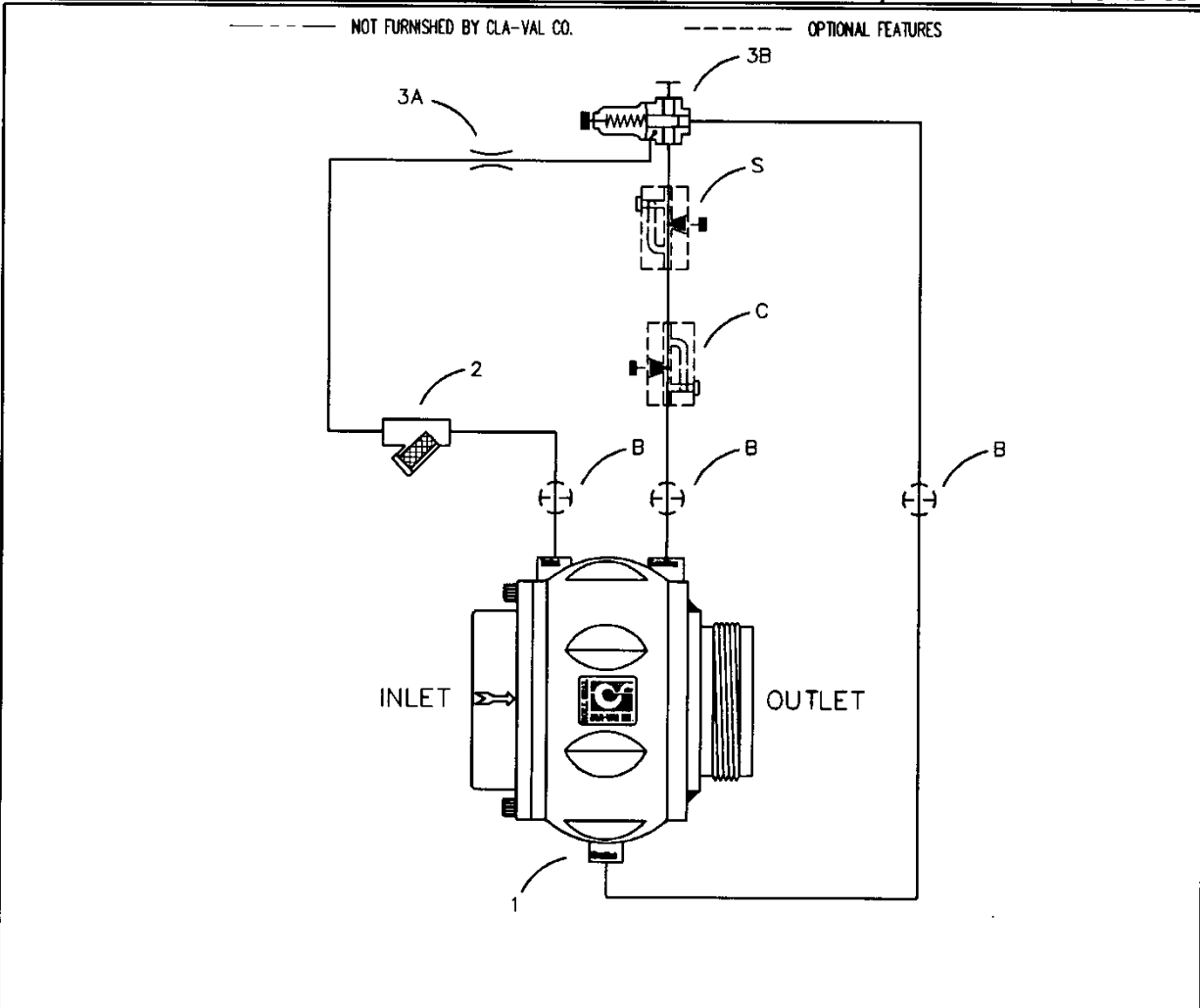

ITEM NO.	BASIC COMPONENTS	QTY
1	100-42FH ROLL SEAL MAIN VALVE	1
2	X43 "Y" STRAINER	1
3	RCBP PRESSURE RELIEF CONTROL W/ BUILT IN RESTRICTOR	1

OPTIONAL FEATURE SUFFIX	ADDED TO CATALOG NUMBER
B CK2 COCK (ISOLATION VALVE)	3
C RCVHP FLOW CONTROL (CLOSING)	1
S RCVHP FLOW CONTROL (OPENING)	1

THIS DRAWING IS THE PROPERTY OF CLA-VAL CO. AND SAME AND COPIES MADE THEREOF, IF ANY, SHALL BE RETURNED TO IT UPON DEMAND. DELIVERY AND DISCLOSURE HEREOF ARE SOLELY UPON CONDITION THAT THE SAME SHALL NOT BE USED, COPIED OR REPRODUCED, NOR SHALL THE SUBJECT HEREOF BE DISCLOSED IN ANY MANNER TO ANYONE FOR ANY PURPOSE, EXCEPT AS HEREIN AUTHORIZED, WITHOUT PRIOR WRITTEN APPROVAL OF CLA-VAL CO. THIS DRAWING IS SUBMITTED CONFIDENTIALLY AND MAY NOT BE USED IN THE MANUFACTURE OF ANY MATERIAL OR PRODUCT OTHER THAN SUCH MATERIALS AND PRODUCTS FURNISHED TO CLA-VAL CO. WHETHER OR NOT THE EQUIPMENT OR INFORMATION SHOWN HEREON IS PATENTED OR OTHERWISE PROTECTED, FULL TITLE AND COPYRIGHTS, IF ANY, IN AND TO THIS DRAWING AND/OR INFORMATION DELIVERED OR SUBMITTED ARE FULLY RESERVED CLA-VAL CO.

CLA-VAL CO.

NEWPORT BEACH, CALIFORNIA

CATALOG NO.

750-60

DRAWING NO.

200406

REV

B

TYPE OF VALVE AND MAIN FEATURES

PRESSURE RELIEF VALVE
(FOR FIRE HYDRANT SERVICE)

DESIGN

DRAWN

PLF

8-9-98

CHK'D

CH

8-12-98

APVD

BF

8-12-98

OPERATING DATA

I. PRESSURE RELIEF FEATURE:

PRESSURE RELIEF CONTROL (3) IS A NORMALLY CLOSED CONTROL THAT RESPONDS TO MAIN VALVE INLET PRESSURE CHANGES. AN INCREASE IN INLET PRESSURE TENDS TO OPEN CONTROL (3) AND A DECREASE IN INLET PRESSURE TENDS TO CLOSE CONTROL (3). THIS CAUSES MAIN VALVE LOADING CHAMBER PRESSURE TO VARY AND THE MAIN VALVE MODULATES (OPENS AND CLOSSES) MAINTAINING A RELATIVELY CONSTANT MAIN VALVE INLET PRESSURE.
PRESSURE RELIEF CONTROL (3) ADJUSTMENT: TURN THE ADJUSTING SCREW CLOCKWISE TO INCREASE THE SETTING.

II. OPTIONAL FEATURE OPERATING DATA:

SUFFIX B (ISOLATION VALVES)

CK2 COCKS (B) ARE USED TO ISOLATE THE PILOT SYSTEM FROM MAIN LINE PRESSURE. THESE VALVES MUST BE OPEN DURING NORMAL OPERATION.

SUFFIX C (CLOSING SPEED CONTROL)

FLOW CONTROL (C) CONTROLS THE CLOSING SPEED OF THE MAIN VALVE. TURN THE ADJUSTING STEM CLOCKWISE TO MAKE THE MAIN VALVE CLOSE SLOWER.

SUFFIX S (OPENING SPEED CONTROL)

FLOW CONTROL (S) CONTROLS THE OPENING SPEED OF THE MAIN VALVE. TURN THE ADJUSTING STEM CLOCKWISE TO MAKE THE MAIN VALVE OPEN SLOWER.

III. CHECK LIST FOR PROPER OPERATION:

- () SYSTEM VALVES OPEN UPSTREAM AND DOWNSTREAM.
- () AIR REMOVED FROM THE MAIN VALVE LOADING CHAMBER AND PILOT SYSTEM AT ALL HIGH POINTS.
- () PERIODIC CLEANING OF STRAINER (2) IS RECOMMENDED.

CAD REVISION RECORD - DO NOT REVERSE MANUALLY

DESCRIPTION

DATE

BY

LTR

SEE SHEET 1



— SERIES — **100-42**

700 Series Roll Seal

DESCRIPTION

The Cla-Val Model 100-42 Roll Seal valve is a hydraulically operated valve used to control liquid flow by means of a flexible control element, the liner.

The basic valve consists of only two parts: a one piece, investment cast body and an elastomeric liner. The valve body is constructed with internal ribs and slots forming a grillwork which surrounds the liner to provide support. A normally closed type valve is formed by the installed liner which covers the grillwork and seats against the raised seating surface in the valve body.

Upstream pressure actuates the valve to produce valve opening by rolling the liner off the seating surface and the slotted grillwork.

The valve is actuated by upstream pressure as the loading pressure (pressure supplied to the control chamber) is varied by an external pilot control system.

A typical pilot control system used to operate the Model 100-42 valve consists of a restriction and a suitable pilot connected to the valve.



PRINCIPLE OF OPERATION

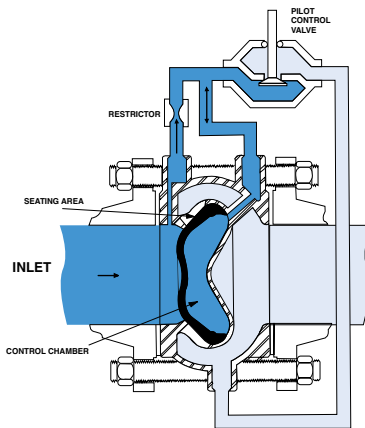

**Model 100-42 Valve
in Closed Position**

Upstream pressure is introduced to the control chamber (the chamber formed behind the liner) through the control piping and restrictor. When the pilot is closed, full inlet pressure is supplied to the control chamber, thus balancing the force developed by inlet pressure acting on the upstream face on the liner. Under these conditions, the liner remains in the fully closed position.

Since the operating pressure in the control chamber is greater than the outlet pressure, an additional closing force is developed across the liner, pressing the liner against the surrounding slotted grillwork area and seating surface.

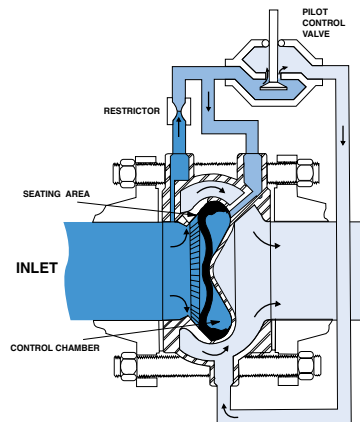

**Model 100-42 Valve
in Partially Open Position**

As loading pressure is lowered slightly below inlet pressure, the central portion of the liner is forced to invert and come to rest against the tip of the control chamber cavity. Reducing the loading pressure further (but still higher than outlet pressure) causes the liner to drape over the cone shaped portion of the control chamber cavity. This action causes the outer section of the liner to roll off the seating surface and a portion of the grillwork to partially open the valve.

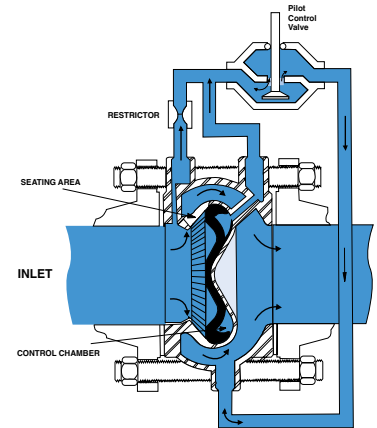

**Model 100-42 Valve
in Fully Open Position**

The valve is fully opened when loading pressure is sufficiently reduced to allow the liner to roll back completely and expose the full slot area. Restoring loading pressure reverses the liner rolling action to return the liner to the fully closed position.

INSTALLATION

The Cla-Val Model 100-42 Roll Seal valve in 2", 3", and 4" sizes are designed to mount between standard pipe flanges (ANSI 125, 150, 250, and 300 series) as a wafer type valve. The outer portion of the valve body is constructed with fluted (recessed) sections to provide clearance for the class 125 and 150 flange bolt pattern while the basic outside diameter of the body centers within the class 250 and 300 flange bolt pattern.

The Model 100-42 valve in 6" through 12" sizes are constructed with separable "slip-on" style flanges. Furnished standard in either class 150 or 300 raised face type, the flanges are removable and interchangeable. The class 150 flange may be bolted up to class 125 pipeline flanges and the class 300 flange may be mated against a class 250 flange.

Locate pilot system port connections at the top of valve in pipeline to allow easy air venting. A line size strainer is recommended, mounted on the valve inlet.

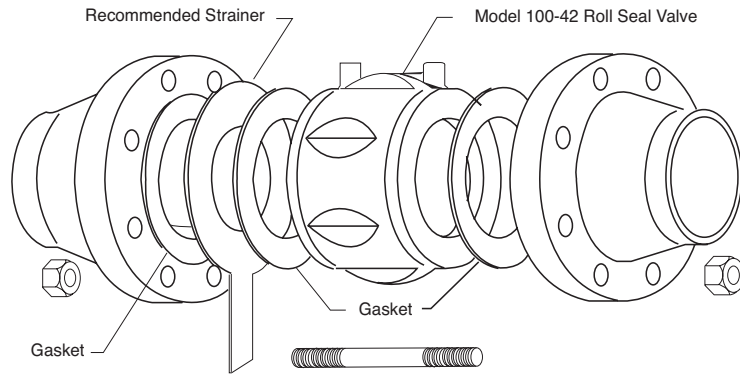

PROCEDURE

1. The valve should be given a visual inspection before installation to be sure no foreign materials have collected inside the valve during shipment or storage.
 2. Pipelines should be flushed out before the valve is installed in the system. New systems, especially, should be cleaned as contaminants such as welding beads, scale, rocks, etc. are commonly contained within the pipeline.
 3. The valve should be installed in a location allowing sufficient working space around the valve to provide easy access for maintenance and removal for servicing.
 4. For 2", 3", and 4" sizes only. Insert the lower half pattern of stud bolts through the bolt holes of the upstream and downstream pipeline flanges.
 - 4a. For 2" & 3" valves only. The 125 and 150 series flanges use a different number of bolts than the 250 and 300 series flanges. Hence, the wafer valve body configuration is inherently self centering regardless of the flange used.
 - 4b. For the 4" valve, ANSI pipe flanges use an 8 bolt pattern regardless of pressure ratings, although the 250 and 300 series use larger bolts on a larger bolt circle. The 4" valve can be centered in the larger 250 and 300 class flanges by rotating the valve body into full radial contact with the bolt studs prior to tightening.
 5. If an inline basket type strainer is to be included in the installation, insert the strainer into the upstream pipe, making sure a gasket is placed between the strainer and the upstream flange.
 6. Install the valve between the flanges being sure to include the appropriate flange gaskets between each end of the valve and the mating pipe flange.
- Note: The valve must be installed with the flow arrow on side of body pointing to the downstream piping section. Cla-Val 700 Series valves may be installed in any position in either vertical or horizontal installations without any effect on valve operation.
7. Insert the remaining stud bolts and nuts and tighten evenly using a diagonal cross-over type pattern.

Liner Retainer Removal 2"-12" Sizes

The 2" and 3" liner retainer is secured to the valve with an Allen screw. Loosen the Allen screw, pull the locking pin back towards center of retainer, and remove the retainer from valve.

To install, insert the retainer, (do not block inlet feed hole), push locking pin into position and tighten Allen screw.

The 4"-12" liner retainers are secured with a snap ring. Remove the snap ring and retainer.

To install, insert retainer and install snap ring into the groove of valve. Be sure snap ring is completely inserted into groove.

Liner Removal 2"-12" Sizes

The tool used for removal should be free of sharp edges to prevent damage to the liner, the valve body seat or control chamber surfaces. A motorcycle tire iron or similar tool works well.

1. Insert the tool between the liner and the valve body as deeply as possible.
2. Using the seat edge as a fulcrum, rock the end of the tool away from the valve in a manner to pull the liner bead out of the body. Grasp the liner and remove from the valve body.

Liner Installation 2", 3", 4" Sizes

Thoroughly clean out the interior of the valve body control chamber cavity.

Liberal apply glycerine inside the control chamber cavity and around the seal bead area of the liner.

DO NOT USE ANY HYDROCARBON OR SILICONE BASED LUBRICANTS ON LINERS AS THESE COMPOUNDS CAN SEVERELY ATTACK THE LINER MATERIAL.

3. Fold the liner as shown and install into the valve body control chamber as deeply as possible.
4. Continuing to force the liner into the control chamber cavity, again fold the liner as shown to insert the liner seal bead section under the valve body seat surface.
5. Work the folded section of the liner into place by pushing against the folded area to slide the seal bead down the conical face of the control chamber.

Liner Seating Instructions 2", 3", 4" Sizes

After installing the liner, it must be seated over the manifold ring in the valve body. The objective of this seating procedure is to place the inside lip of the liner over the outside lip of the manifold ring.

6. 4" valve with liner installed.
7. Pinch, pull and knead the liner 360° around to seat the liner on the manifold ring.
8. Using a dull tool or hammer handle, pry the outer part of the liner towards the center to help "seat" the liner.
9. Now push the liner down into the valve, holding your hand on the depressed liner, seal off the loading port with your finger.
10. Remove your hand from liner and continue holding your finger over the loading port. If liner is seated, it will be held in the open position as long as your finger is over the loading port. When you release your finger, the liner will pop up. If not seated, repeat with Step 7.

Install liner retainer into body.



1



2

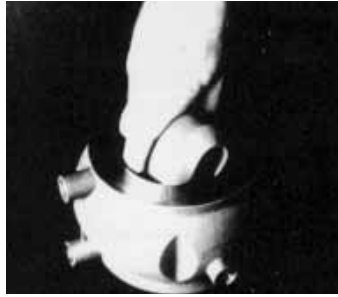

3



4



5



6



7



8



9



10

Liner Installation

6", 8", 10", 12" sizes

1. Tools required: Bottle of drugstore glycerine, 30" crowbar, double headed plastic hammer with 14" handle, rubber mallet and large flat blade screwdriver.
2. Liberally wipe glycerine on the inside of the valve and on the outer edge of the liner. Fold liner in half and insert into valve body.
3. Push liner in as far as possible forcing it out side ways.
4. Place the crowbar at the upper 25% point of the liner. Take your other hand and push on nose of liner to bend the liner over the crowbar. The less material folded over, the easier it will go into the valve. If too much is folded over, it will be difficult to complete liner installation.
5. Continue bending liner nose down into the valve. Use your hands and/or hammer handle to continue forcing it down into valve. It is important to keep the "V" of the bend near the 25% point. If it goes over the center, The liner won't go in, and it will be necessary to start over at Step 3.
6. Use the hammer to force the liner down and out into the valve body.
7. Use the hammer handle for the final insertion. Sometimes it is helpful to beat on the liner with the hammer for the final step.
8. To seat the liner on the manifold ring use the hammer handle to push down on the liner near bore of valve inlet and pry handle and liner towards the center. Continue this prying action for 360° around the liner for proper seating.
9. To test for liner seating, push down on the center of liner and close the loading port shut-off cock, or block it with your hand. When you release your hand from the liner, it should remain in the down position until the loading port is opened.
10. If liner appears seated, open loading port cock and liner should pop-up to the closed position. Repeat Steps 6-10 if liner is not seated.

When the liner is fully seated, the inside diameter of the liner will be seated over the outside diameter of the manifold ring. The manifold ring is a raised circular ridge at the bottom of the open cavity which provides for even distribution of the fluid coming in and going out the loading port.

Install liner retainer into body.

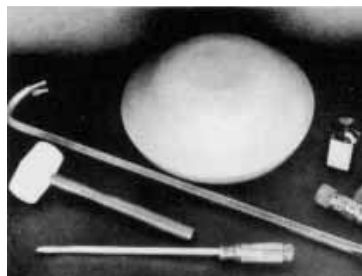

1



2



3



4



5



6



7



8



9



10

PLACING VALVE INTO OPERATION **Important Procedure for All Installations:**

In most instances, the 700 Series Cla-Val Control valves will be shipped complete with a pilot control system mounted on the Model 100-42 valve. Consult the appropriate start up and operation instructions for the pilot control used before pressurizing the system.

IT IS IMPORTANT THAT THE PRESSURIZATION AND DEPRESSURIZATION OF ALL INSTALLATIONS BE CARRIED OUT IN A MANNER TO PREVENT IMPOSING A REVERSE PRESSURE CONDITION ON THE CLA-VAL MODEL 100-42 VALVE. PRESSURIZATION OF THE SYSTEM SHOULD BE ACCOMPLISHED BY PRESSURIZING THE INLET SIDE FIRST.

DEPRESSURIZATION OF THE SYSTEM SHOULD BE ACCOMPLISHED BY DEPRESSURIZING THE OUTLET SIDE FIRST. FAILURE TO FOLLOW THIS PROCEDURE COULD RESULT IN DISLODGE- MENT AND/OR DESTRUCTION OF THE RUBBER LINER.

START-UP INSTRUCTIONS

Pressure Reducing 790 Series Valves

The following instructions are for valves equipped with a Model CRD Pressure Reducing Pilot Control.

1. Remove the adjustment cap and back off adjustment screw setting (turn counterclockwise) of the CRD Pressure Reducing Pilot Control to fully relieve all loading on the range spring.
2. Slowly open the **upstream** main line block valve to pressurize the **inlet** section of the valve.
3. Bleed any entrapped air from the control chamber of the valve and tubing sections by loosening fittings at the highest points. Retighten fittings. Install gauge on downstream port of CRD.
4. Slowly increase tension on the range spring, by means of the adjustment screw (turn clockwise) until the desired downstream pressure is attained. Use a gauge.
5. Open the downstream main line block valve.
6. If required, reset the pilot adjustment screw setting to obtain the downstream pressure desired.
7. Tighten the adjustment screw lock nut and replace the adjustment cap.

Back Pressure Control 750 Series Valves

The following instructions are for valves equipped with a Model CRL Back Pressure Pilot Control.

1. Remove the adjustment cap and increase tension on the range spring, by means of the adjustment screw (turn clockwise) until maximum spring load is attained.
2. Slowly open the **upstream** main line block valve to pressurize the **inlet** section of the valve.
3. Bleed any entrapped air from the control chamber of the valve and tubing sections by loosening fittings at the highest points. Retighten fittings.
4. Open the downstream main line block valve.
5. Gradually decrease tension on the range spring by means of the adjustment screw (turn counterclockwise) until upstream pressure decreases to the desired setpoint.
6. Tighten the adjustment screw lock nut and replace the adjustment cap.

Relief Valve Applications 750 Series Valves

The following instructions are for valves equipped with a Model CRL Pressure Relief Pilot Control.

Due to the nature of intended use, the system being protected with the relief valve will most likely not be able to furnish the pressure source needed to establish the proper setpoint of the pilot control. Due to this fact, in most instances, the relief valve setting procedures will either have to be carried out at other locations or an auxiliary pressure source will have to be supplied at the site in order to carry out the following procedure.

1. Remove the adjustment cap and increase tension on the range spring by means of the adjustment screw (turn clockwise) until maximum spring load is attained.
2. Slowly introduce **inlet** pressure to the valve at the desired setpoint value. Bleed all air.
3. Gradually decrease tension on the range spring by means of the adjustment screw (turn counterclockwise) until flow is initiated through the valve.
4. Reduce system pressure back to normal value. Tighten the adjustment screw lock nut and replace the adjustment cap. The valve is now ready for service.

Taking Valve Out of Service

The following procedure should be followed when taking the Model 100-42 valve out of service.

1. Close the upstream main line block valve first. Then close the downstream main line block valve.
 2. Vent the **downstream** section to fully relieve pressure in the outlet section of the valve.
 3. Vent the **upstream** section to fully relieve pressure in the inlet section and control chamber of the Model 100-42 valve.
 4. If the valve liner is to be inspected or replaced, remove the valve from the main line.
-
-

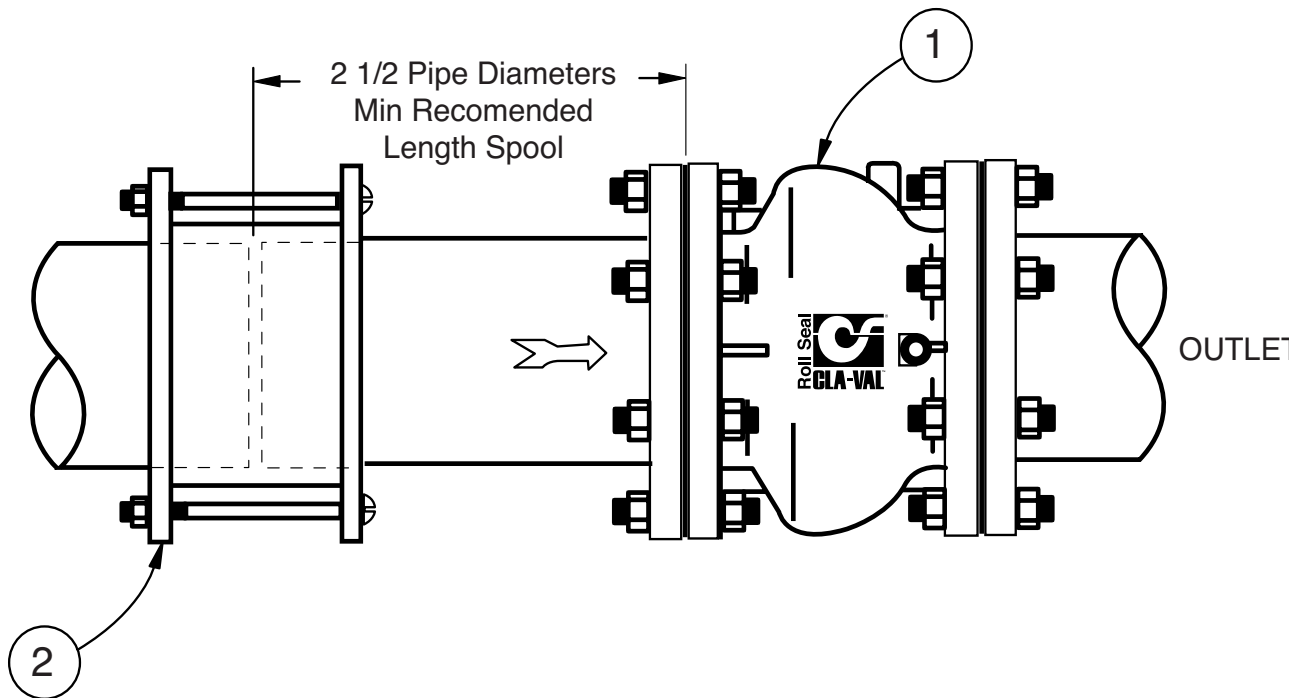

Recommended Pipe layout
6" - 12" Flange style 100-42

- 2 Pipe Coupling (Rubber Gasket Type)
- 1 100-42 Main Valve, Flange X Flange

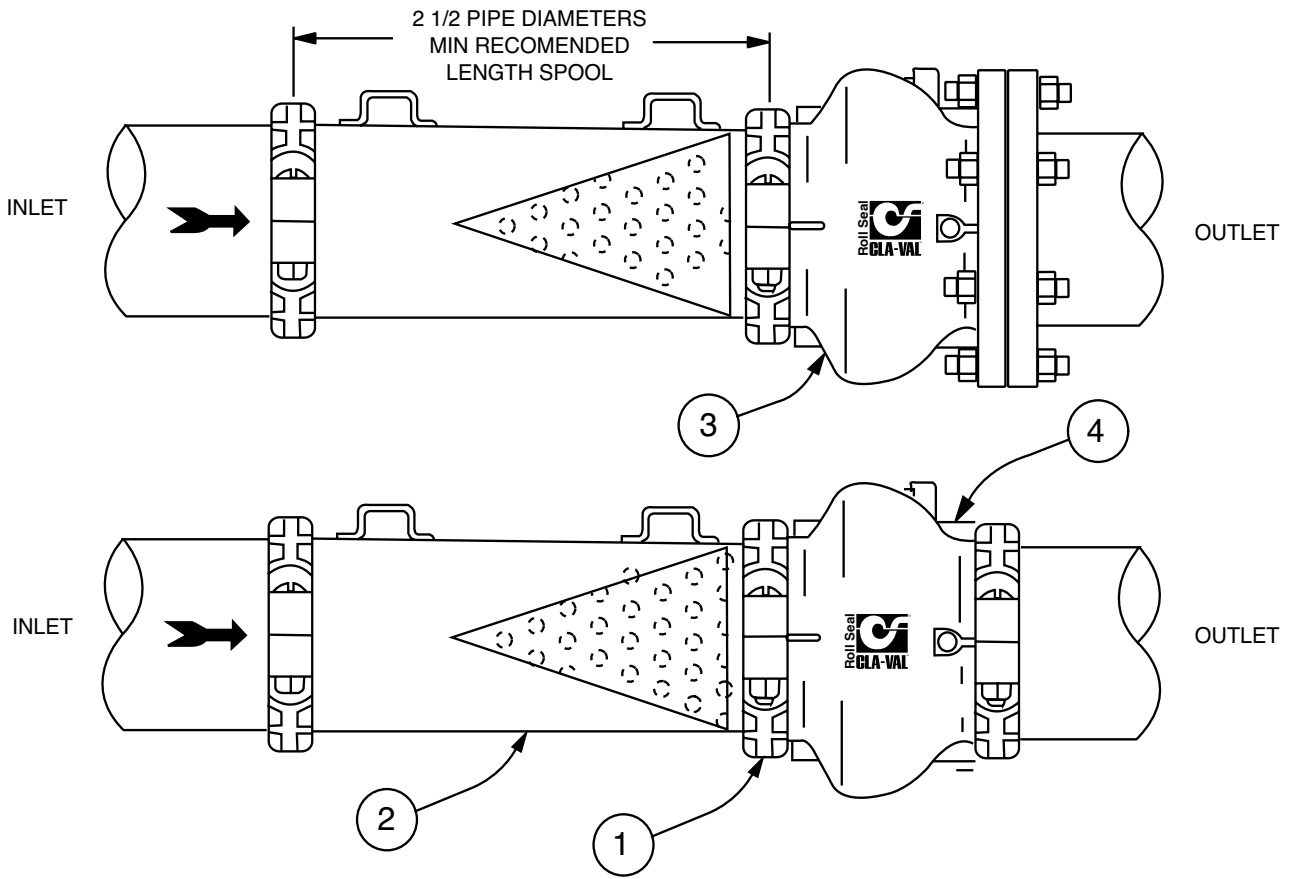

Recommended Pipe layout
6" - 12" Grooved style 100-42

- 1 COUPLER FOR GROOVED PIPE
- 2 SPOOL STRAINER ASSEMBLY (WITH CONE)
- 3 100-42 MAIN VALVE, GROOVE X FLANGE
- 4 100-42 MAIN VALVE, GROOVE X GROOVE

**When ordering
please specify:**

- All nameplate data
- Description
- Part Numbers
- Item Number
- Material

Item No.	Description	No. Req'd	Material (Standard)
1	Body	1	316L Stainless Steel "L"
2*	Liner	1	Natural Rubber
3	Nameplate	1	Aluminum
4	Drive Screw	2	316L Stainless Steel
5	Liner Retainer	1	316L Stainless Steel
6	Retaining Ring	1	316L Stainless Steel
7	Slip-on Flange	2	Steel-Cad. Pl.
8	Flange Retainer Ring	2	Steel-Cad. Pl.

*Recommended Spare Part

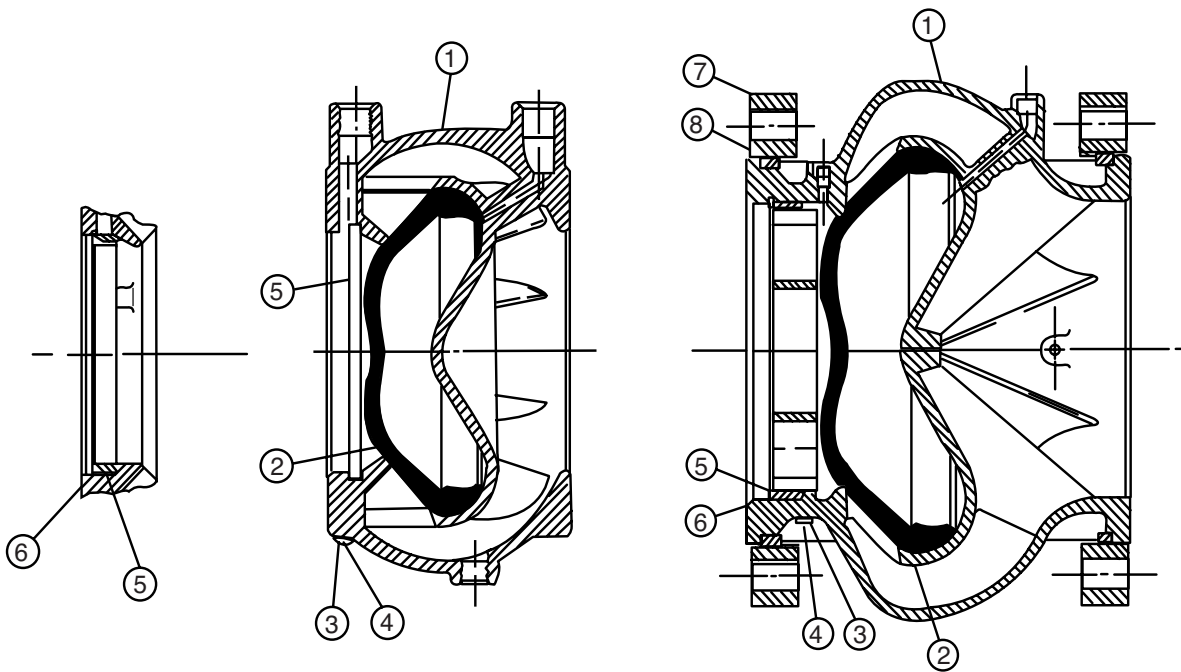

4" Wafer Style Valve

2-3" Wafer Style Valve

6"-12" Flanged Valve



X43 Strainer

ITEM	DESCRIPTION	MATERIAL
1	Pipe Plug	Steel
2	Strainer Plug	Brass
3	Gasket	Copper
4	Screen	SST
5	Body	Brass

Standard 60 mesh pilot system strainer for fluid service.

SIZE	STOCK NUMBER
3/8 x 3/8	33450J

No parts available. Replacement assembly only.

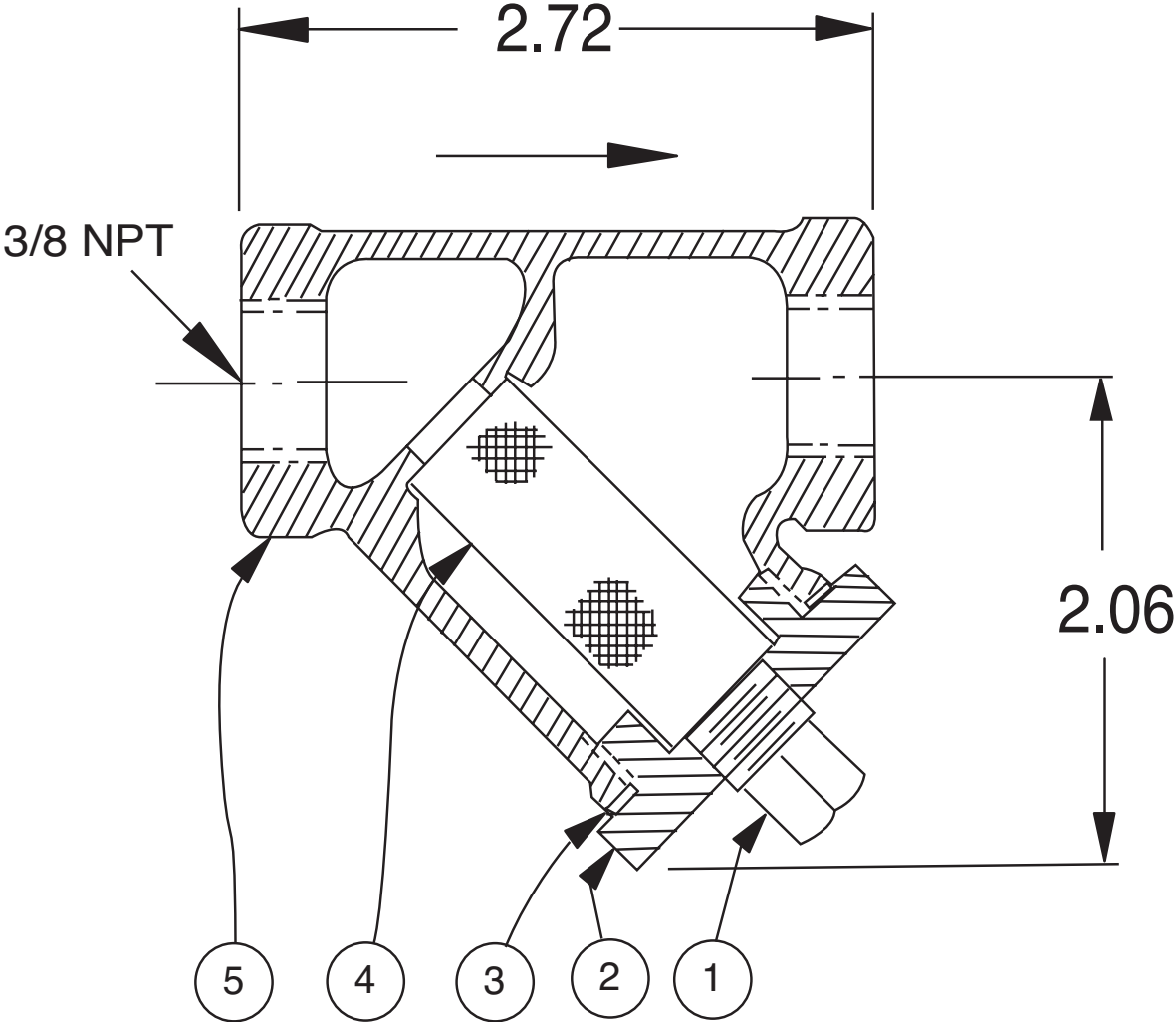

This page was intentionally left blank!

— MODEL — **RCBP**

Back Pressure Control and Relief Pilot

Principle of Operation

The model RCBP pilot is used with Cla-Val control valves to form a control unit to function in either back pressure regulation or pressure relief service.

Back Pressure Regulation Service

Accurately maintains upstream pressure regardless of flow demand or downstream pressure conditions.

Pressure Relief Service

Provides protection against excessive main line system pressure.

Figures A and B schematically depict the RCBP connected to a hydraulically operated valve.

Upstream pressure is supplied to the diaphragm chamber. From here it is transmitted to the loading pressure chamber through the restrictor (formed by an axial groove along the plunger guide bore). When the upstream pressure is less than

the setting established by the pressure spring, the plunger is in the closed position as shown in Figure A, thus full upstream pressure is provided to the control chamber of the main valve. Since the control chamber and upstream pressures are equal, the main valve remains in the closed position. When a rising upstream pressure exceeds the pressure spring setting, the plunger is shifted off the seat towards the open position shown in Figure B. Flow is then established through the pilot circuit and exhausted through the discharge port into the downstream system. As a result of pilot circuit flow, a pressure drop is developed across the restrictor. Hence, the pressure supplied to the control chamber is reduced permitting the main valve to open and maintain a steady upstream pressure.

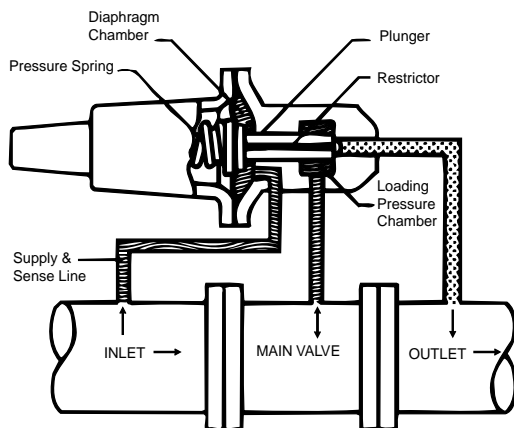

Figure A

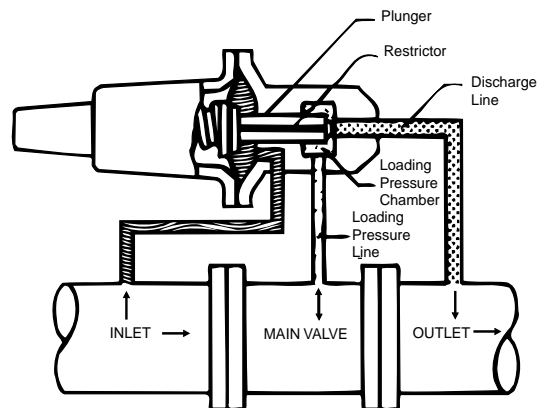

Figure B

Installation

The model RCBP pilot has one inlet port (marked "sense"), two loading ports (marked "loading") and one outlet port. A flow arrow is stamped on the side of the pilot body, near the outlet port, indicating flow direction through the pilot. The second loading port is an auxiliary port and may be used for mounting of a pressure gauge.

The pilot may be mounted in any desired position. When installing the model RCBP as a pilot control on a main valve, connect the pilot as follows:

1. Connect one of the "loading" pressure taps on the model RCBP to the "loading" pressure tap on the main valve body. Plug the second "loading" pressure tap on the pilot if it is not to be used.
2. Connect a line from the "sense" port of the pilot to the "inlet" port tap on the main valve body or to a pressure tap connection in the upstream system as desired.
3. Connect a line from the "outlet" port of the pilot to the "outlet" port tap on the main valve body.
4. All line connections should be a minimum of 3/8" pipe or tubing size. If the "sense" line connection is made to a pressure tap location further than two feet from the valve, the connecting line should be stepped up at least one size.
5. It is recommended that a small strainer be added in the sense line to the pilot to prevent clogging.

Maintenance

The procedure outlined below should be followed when servicing the model RCBP Back Pressure Control and Relief Pilot. Item numbers, appearing with part names, are keyed to the cross sectional parts list drawing.

Disassembly

1. Remove the adjustment cap (Item 11) and the adjustment screw (Item 14) to fully relieve compression of the range spring.
2. Remove the eight body screws (Item 10) and lift off the spring housing (Item 20).
Remove the range spring (Item 19) and the spring pad (Item 16).
3. Remove the diaphragm (Item 3) and attached parts from the body.
4. Inspect the diaphragm for wear or damage and inspect the plunger (Item 2) for signs of erosion or damage, particularly in the area of the seating surface.
5. If any part shows damage, take the assembly apart and replace the damaged component. Disassemble by removing the cap screw (Item 9) from the plunger. Be very careful not to damage the plunger surface during this operation. Wrench flats are provided on the plunger to hold the part while removing the cap screw.
6. Remove the retaining ring (Item 8).
7. Remove the guide bushing (Item 4) and the seat (Item 1) from the body. An easy method of removal is to insert the plunger through the outer port of the body and push against the back surface of the seat.
8. Inspect the "O" rings (Item 12 and 13) and the seat (Item 1) for damage. Pay particular attention to the sealing edge on the seat and replace any parts showing damage.

Reassembly

1. Thoroughly clean all parts prior to reassembly. It is recommended that a light film of grease or oil be applied to all "O" rings to ease assembly into body. It is also recommended that a heavy bodied grease be applied to the ball tip of the adjustment screw (Item 14) before assembly into the spring housing.
2. Insert the seat and guide bushing, with "O" rings in place, into the pilot body (Item 7). Install the retaining ring (Item 8) into the groove.
3. Place the upper diaphragm plate (Item 5), the diaphragm (Item 3) and the lower diaphragm plate (Item 6) onto the cap screw (Item 9). Insert the cap screw into the plunger (Item 2) and tighten. Be very careful not to damage the plunger surface during this operation. Wrench flats are provided on the plunger to hold the part while tightening the cap screw.
4. Slide the plunger into the guide bushing and rotate the diaphragm to line up the clearance holes in the diaphragm with the tapped holes in the body.

5. Install the range spring (Item 19) onto the upper diaphragm plate and install the spring pad (Item 16) onto the spring.
6. Set the spring housing (Item 20) onto the diaphragm and install the eight body screws (Item 10). Tighten the body screws uniformly using a diagonal pattern to prevent uneven loading on the diaphragm.
7. Install the adjustment screw assembly (Item 14), including lock nut (Item 15) and adjustment cap (Item 11) on the spring housing.

Item No.	Description
1*	Seat
2	Plunger
3*	Diaphragm
4	Guide Bushing
5	Upper Diaphragm Plate
6	Lower Diaphragm Plate
7	Body
8	Retaining Ring
9	Cap Screw
10	Body Screw
11	Adjustment Cap
12*	"O" Ring
13*	"O" Ring
14	Adjustment Screw Assembly
15	Lock Nut
16	Spring Pad
17	Nameplate
18	Drive Screw
19	Range Spring
20	Spring Housing

* Recommended Spare Part

Pressure Adjustment

1. Remove the adjustment cap (Item 11).
2. Loosen the adjustment screw lock nut (Item 15).
3. Turn the adjustment screw (Item 14) to obtain the desired controlled pressure setting. To increase the pressure setting, turn the adjustment screw clockwise. To decrease the pressure setting, turn the adjustment screw counterclockwise.
4. Tighten the adjustment screw lock nut and replace the adjustment cap.

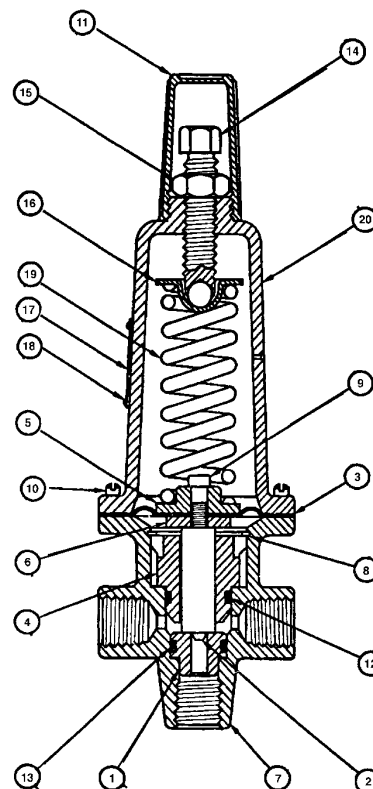

Specifications

Size	3/8" NPT Threaded
Temperature Range	Water: 180°F Max.
Materials	
Body & Cover:	Cast Bronze ASTM B-62
Trim:	Brass & Stainless Steel 303
Rubber:	Buna-N® (Fabric Reinforced)

Adjustment Ranges	
psi:	10-90 (Silver)
	25-150 (Red)
	50-300 (Blue)
	100-500 (Black)

Optional Materials	Bronze/Stainless Steel 316
	Stainless Steel 316
	Acetal Plastic
	Viton & EPDM Rubber

Mounting Positions:
Multi-poise
(operates in any position)

Pressure Rating	720 psi Max. (All materials)
------------------------	---------------------------------

Weight: 4 lbs

When Ordering, Please Specify

1. Adjustment Range Desired
2. Materials Desired

 CLA-VAL CO. NEWPORT BEACH, CALIFORNIA	CATALOG NO.	DRAWING NO.	REV
		67783	BA
TYPE OF VALVE AND MAIN FEATURES		DESIGN	
CK2 COCK/BALL VALVE		DRAWN	MGR 4-02-80
		CHK'D	KD 4-03-80
		APV'D	CH 4-07-80

SCALE: NONE

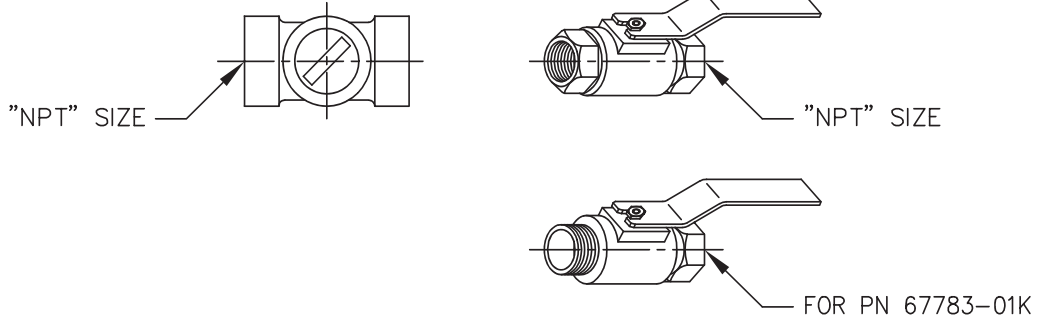

CLA-VAL PART NO. AND MATERIAL

BRONZE WITH HANDLE	STEEL WITH HANDLE	IRON WITH HANDLE	316 SST WITH HANDLE	316 SST W/ LOCKING HANDLE	BRONZE WITH HANDLE	MONEL WITH HANDLE	SIZE "NPT"
67783-01K*	-09C	-17F	-25J SUPSD BY-26G		-41F SUPSD BY-01K		1/8"
-02H	-10A	-18D	-26G	-51E SUPSD BY-26G -52C	-42D SUPSD BY-02H	-55F	1/4"
-03F * -59H***	-11J	-19B	-27E	-46E SUPSD BY-27E -53A	-45G -57B * *	-48A SUPSD BY-49J	3/8"
-04D -60F ***	-12G	-20K	-28C	-54J	-43B SUPSD BY-04D	-49J	1/2"
-05A -61D ***	-13E	-21H	-29A		-44K SUPSD BY-05A	-56D	3/4"
-06J	-14C	-22F	-30J			-58K	1"
-07G	-15K	-23D	-31G				1 1/4"
-08E	-16H	-24B	-32E				1 1/2"
-50G			-47C				2"

- * SEE ENGINEERING APPROVED VENDORS TABLE (SHEET 2 OF 2).
- ** HAMMOND VALVE 8501 ONLY.
- *** WILKINS CK2 (SEE SHEET 2 OF 2)

CAD REVISION RECORD - DO NOT REVISE MANUALLY	
DESCRIPTION	DATE
BY	
AK	03-14-06
LTR	
A-AY SEE REVISION FILE	
BA ADDED PN'S 67783-59H, 67783-60F & 67783-61D (ECO 20434)	

*THIS DRAWING IS THE PROPERTY OF CLA-VAL CO. AND SAME AND COPIES MADE THEREOF, IF ANY, SHALL BE RETURNED TO IT UPON DEMAND. DELIVERY AND DISCLOSURE HEREOF ARE SOLELY UPON CONDITION THAT THE SAME SHALL NOT BE USED, COPIED OR REPRODUCED, NOR SHALL THE SUBJECT HEREOF BE DISCLOSED IN ANY MANNER TO ANYONE FOR ANY PURPOSE, EXCEPT AS HEREIN AUTHORIZED, WITHOUT PRIOR WRITTEN APPROVAL OF CLA-VAL CO. THIS DRAWING IS SUBMITTED CONFIDENTIALLY AND MAY NOT BE USED IN THE MANUFACTURE OF ANY MATERIAL OR PRODUCT OTHER THAN SUCH MATERIALS AND PRODUCTS FURNISHED TO CLA-VAL CO. WHETHER OR NOT THE EQUIPMENT OR INFORMATION SHOWN HEREON IS PATENTED OR OTHERWISE PROTECTED, FULL TITLE AND COPYRIGHTS, IF ANY, IN AND TO THIS DRAWING AND/OR INFORMATION DELIVERED OR SUBMITTED ARE FULLY RESERVED CLA-VAL CO. *

This page was intentionally left blank!

FLOW CONTROLS

KLF SERIES

Designed for the precise control of hydraulic and pneumatic actuators. Provides metered flow in one direction and free-flow in the reverse direction.

FEATURES

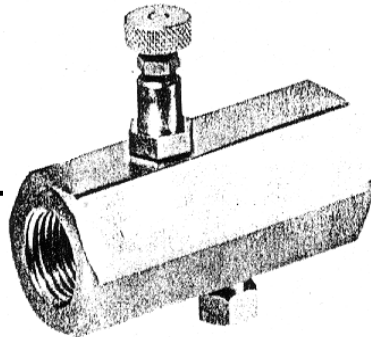

ORDERING INFORMATION

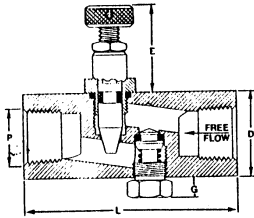

Accurate

- Precision-machined long tapered stem with fine threading provides exact control.
- Lock nut included to secure flow setting.
- Soft-seat piston check for leak-free service.

Durable

- Optional ball check for high cycle applications.
- Rugged, all-metal construction - no plastic parts.
- Steel valves are zinc-plated and sealed with "golden glow" chromate for double corrosion protection.

PART NUMBER	P (NPT) Female	D (In.) Hex	G (In.)	L (In.)	E (In.) Max	Orifice Diam. (In.)	C _V (Free flow direction)	C _V (Controlled flow direction)	Cracking Pressure (PSIG)			
BRASS												
STEEL												
316SST												
KLF125B(2)(1)	-	-	KLF125SS6V(3)	1/8	11/16	9/32	1 3/4	1 1/4	.156	.32	.23	1 1/2
KLF250B(1)	KLF125SBC	KLF250SS6V(3)	1/4	7/8	5/16	2 3/8	1 1/4	1 1/4	.156	.70	.44	1 1/2
KLF375B(1)	KLF375SBC		3/8	1 1/16	11/32	2 3/4	1 3/8	1 3/8	.265	1.14	.90	2
KLF500B(1)	KLF500SBC		1/2	1 5/16	3/8	3 3/16	1 3/8	1 3/8	.281	1.74	1.32	3
KLF750B(1)	KLF750SBC		3/4	1 5/8	15/32	3 9/16	1 7/8	1 7/8	.343	2.91	2.02	4
KLF1000B	-	-	1	1 7/8	15/32	3 9/16	1 7/8	1 7/8	.343	2.91	2.02	4

- (1) For stainless steel ball check style-designate with suffix "BC" after Part No. (Not available on 1" size).
 (2) Available with Viton soft-seat ball check-designate Part No. KLF125BBC-2 (For air service up to 125 psi only).
 (3) Body, chamber & piston 316SST. All seals Viton.

SPECIFICATIONS

Maximum Operating Pressure Ball Check Models:
 Steel 5,000 psig
 Brass 2,000 psig
 Piston Check Models:
 Brass 2,000 psig

Temperature Range -20°F to + 212°F

Materials:

Body 12L14 Steel or ASTM B16 Brass
 Piston Assembly Stainless steel with Buna-N O-ring
 Ball Stainless steel (See note 1)
 Spring Stainless steel
 Stem Stainless steel
 Knob Aluminum on 1/8-1/2 sizes, Brass on 3/4 to 1"
 Check Plug Steel or Brass
 Chamber Steel
 Set Screw Steel (black oxide)
 Lock Nut Brass
 Stem Packing Buna-N O-ring with "Teflon" backup

C_V Factor See ordering information

Stem Taper 8°

Stem Pitch 40 Threads/Inch on 1/8, 1/4, 3/8
 and 1/2" sizes
 24 Threads/Inch on 3/4 and 1" sizes

PERFORMANCE CURVES

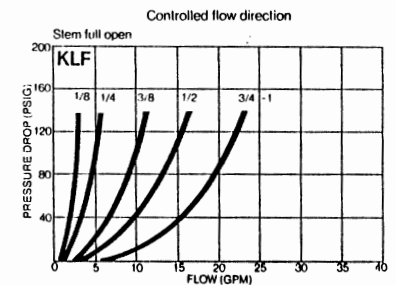
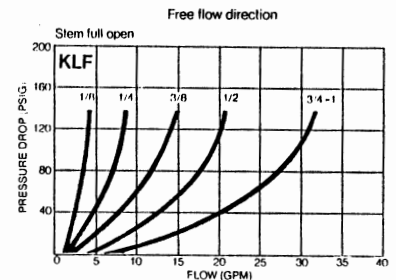

This page was intentionally left blank!

Proper Identification

For ordering repair kits, replacement parts, or for inquiries concerning valve operation, it is important to properly identify Cla-Val products already in service by including all nameplate data with your inquiry. Pertinent product data includes valve function, size, material, pressure rating, end details, type of pilot controls used and control adjustment ranges.

Identification Plates

For product identification, cast-in body markings are supplemented by identification plates as illustrated on this page. The plates, depending on type and size of product, are mounted in the most practical position. **It is extremely important that these identification plates are not painted over, removed, or in any other way rendered illegible.**

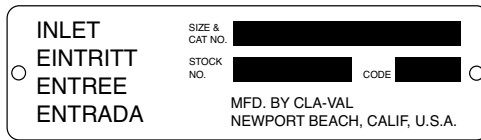

This brass plate appears on valves sized 2 1/2" and larger and is located on the top of the inlet flange.

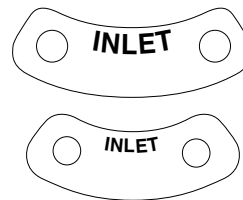

These two brass plates appear on 3/8", 1/2", and 3/4" size valves and are located on the valve cover.



This brass plate appears on altitude valves only and is found on top of the outlet flange.

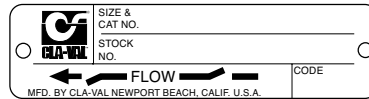

These two brass plates appear on threaded valves 1" through 3" size or flanged valves 1" through 2". It is located on only one side of the valve body.

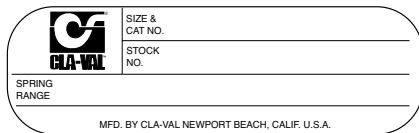

This tag is affixed to the cover of the pilot control valve. The adjustment range appears in the spring range section.

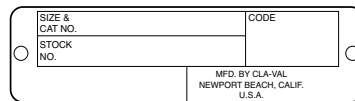

This brass plate is used to identify pilot control valves. The adjustment range is stamped into the plate.

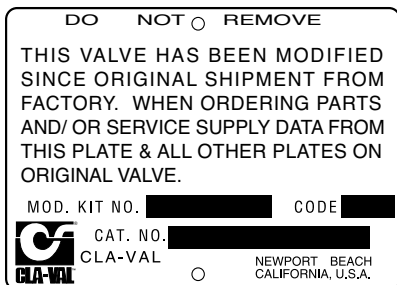

This aluminum plate is included in pilot system modification kits and is to be wired to the new pilot control system after installation.

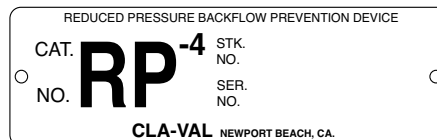

This brass plate is used on our backflow prevention assemblies. It is located on the side of the Number Two check (2" through 10"). The serial number of the assembly is also stamped on the top of the inlet flange of the Number One check.

HOW TO ORDER

Because of the vast number of possible configurations and combinations available, many valves and controls are not shown in published product and price lists. For ordering information, price and availability on product that are not listed, please contact your local Cla-Val office or our factory office located at:

P. O. Box 1325
Newport Beach, California 92659-0325
(949) 722-4800
FAX (949) 548-5441

SPECIFY WHEN ORDERING

- Model Number
- Globe or Angle Pattern
- Adjustment Range (As Applicable)
- Valve Size
- Threaded or Flanged
- Body and Trim Materials
- Optional Features
- Pressure Class

UNLESS OTHERWISE SPECIFIED

- Globe or angle pattern are the same price
- Ductile iron body and bronze trim are standard
- X46 Flow Clean Strainer or X43 "Y" Strainer are included
- CK2 Isolation Valves are included in price on 4" and larger valve sizes (6" and larger on 600 Series)

LIMITED WARRANTY

Automatic valves and controls as manufactured by Cla-Val are warranted for three years from date of shipment against manufacturing defects in material and workmanship that develop in the service for which they are designed, provided the products are installed and used in accordance with all applicable instructions and limitations issued by Cla-Val. Electronic components manufactured by Cla-Val are warranted for one year from the date of shipment.

We will repair or replace defective material, free of charge, that is returned to our factory, transportation charges prepaid, if upon inspection, the material is found to have been defective at time of original shipment. This warranty is expressly conditioned on the purchaser's providing written notification to Cla-Val immediate upon discovery of the defect.

Components used by Cla-Val but manufactured by others, are warranted only to the extent of that manufacturer's guarantee.

This warranty shall not apply if the product has been altered or repaired by others, Cla-Val shall make no allowance or credit for such repairs or alterations unless authorized in writing by Cla-Val.

DISCLAIMER OF WARRANTIES AND LIMITATIONS OF LIABILITY

The foregoing warranty is exclusive and in lieu of all other warranties and representations, whether expressed, implied, oral or written, including but not limited to any implied warranties or merchantability or fitness for a particular purpose. All such other warranties and representations are hereby cancelled.

Cla-Val shall not be liable for any incidental or consequential loss, damage or expense arising directly or indirectly from the use of the product. Cla-Val shall not be liable for any damages or charges for labor or expense in making repairs or adjustments to the product. Cla-Val shall not be liable for any damages or charges sustained in the adaptation or use of its engineering data and services. No representative of Cla-Val may change any of the foregoing or assume any additional liability or responsibility in connection with the product. The liability of Cla-Val is limited to material replacements F.O.B. Newport Beach, California.

TERMS OF SALE

ACCEPTANCE OF ORDERS

All orders are subject to acceptance by our main office at Newport Beach, California.

CREDIT TERMS

Credit terms are net thirty (30) days from date of invoice.

PURCHASE ORDER FORMS

Orders submitted on customer's own purchase order forms will be accepted only with the express understanding that no statements, clauses, or conditions contained in said order form will be binding on the Seller if they in any way modify the Seller's own terms and conditions of sales.

PRODUCT CHANGES

The right is reserved to make changes in pattern, design or materials when deemed necessary, without prior notice.

PRICES

All prices are F.O.B. Newport Beach, California unless expressly stated otherwise on our acknowledgement of the order. Prices are subject to change without notice. The prices at which any order is accepted are subject to adjustment to the Seller's price in effect at the time of shipment. Prices do not include sales, excise, municipal, state or any other Government taxes. Minimum order charge \$75.00.

RESPONSIBILITY

We will not be responsible for delays resulting from strikes, accidents, negligence of carriers, or other causes beyond our control. Also, we will not be liable for any unauthorized product alterations or charges accruing there from.

RISK

All goods are shipped at the risk of the purchaser after they have been delivered by us to the carrier. Claims for error, shortages, etc., must be made upon receipt of goods.

EXPORT SHIPMENTS

Export shipments are subject to an additional charge for export packing.

RETURNED GOODS

1. Customers must obtain written approval from Cla-Val prior to returning any material.
2. Cla-Val reserves the right to refuse the return of any products.
3. Products more than six (6) months old cannot be returned for credit.
4. Specially produced, non-standard models cannot be returned for credit.
5. Rubber goods such as diaphragms, discs, o-rings, etc., cannot be returned for credit, unless as part of an unopened vacuum sealed repair kit which is less than six months old.
6. Goods authorized for return are subject to a 35% (\$75 minimum) restocking charge and a service charge for inspection, reconditioning, replacement of rubber parts, retesting, repainting and repackaging as required.
7. Authorized returned goods must be packaged and shipped prepaid to Cla-Val, 1701 Placentia Avenue, Costa Mesa, California 92627.



CLA-VAL

PO Box 1325 Newport Beach CA 92659-0325
Phone: 949-722-4800 • Fax: 949-548-5441

CLA-VAL CANADA

4687 Christie Drive
Beamsville, Ontario
Canada LOR 1B4
Phone: 905-563-4963
Fax: 905-563-4040

CLA-VAL EUROPE

Chemin des Mesanges 1
CH-1032 Romanel/
Lausanne, Switzerland
Phone: 41-21-643-15-55
Fax: 41-21-643-15-50

©COPYRIGHT CLA-VAL 2007 Printed in USA
Specifications subject to change without notice.

www.cla-val.com

Represented By:



— MODEL — **REPAIR KITS**

Complete Replacement Diaphragm Assemblies for 100-01 and 100-20 Hytrol Main Valves
For: Hytrol Main Valves with Ductile Iron, Bronze Trim Materials—**125/150 Pressure Class Only.**
FACTORY ASSEMBLED
 Includes: Stem, Disc Guide, Disc, Disc Retainer, Spacer Washers, Diaphragm, Diaphragm Washer and Stem Nut.

Valve Size	Diaphragm Assembly Stock Number		Valve Size	Diaphragm Assembly Stock Number	
	100-01	100-20		100-01	100-20
3/8" (Also 81-01)	49097K	N/A	6"	40456G	33273E
1/2" - 3/4" (Also 81-01)	C2518D	N/A	8"	45276D	40456G
1"	C2520K	N/A	10"	81752J	45276D
1 1/4"-1 1/2"	C2522 F	N/A	12"	85533J	81752J
2"	C2524B	N/A	14"	89067D	N/A
2 1/2"	C2523D	N/A	16"	89068B	85533J
3"	C2525J	C2524B	20"	N/A	89068B
4"	33273E	C2525J	24"	N/A	89068B

Repair Kits for 100-01/100-20 Hytrol Valves

For: Hytrol Main Valves—**125/150 Pressure Class Only.**
 Includes: Diaphragm, Disc (or Disc Assembly) and spare Spacer Washers.

Buna-N® Standard Material				Viton (For KB Valves)			
Valve Size	Repair Kit Stock Number		Valve Size	Repair Kit Stock Number			
	100-01	100-20		100-01	100-20		
3/8" (Also 81-01)	9169801K	N/A	3/8" (Also 81-01)	9169806J	N/A		
1/2" - 3/4" (Also 81-01)	9169802H	N/A	1/2" - 3/4" (Also 81-01)	9169807G	N/A		
1"	9169803F	N/A	1"	9169808E	N/A		
1 1/4" - 1 1/2"	9169804D	N/A	1 1/4" - 1 1/2"	9169809C	N/A		
2"	9169805A	N/A	2"	9169810A	N/A		
2 1/2"	9169811J	N/A	2 1/2"	9169817F	N/A		
3"	9169812G	9169805A	3"	9169818D	9169810A		
4"	9169813E	9169812G	4"	9169819B	9169818D		
6"	9169815K	9169813E	6"	9169820K	9169819B		
8"	9817901D	9169815K	8"	9169834A	9169820K		
10"	9817902B	9817901D					
12"	9817903K	9817902B					
14"	9817904H	N/A					
16"	9817905E	9817903K					
20"	N/A	9817905E					
24"	9817906C	9817905E					

When ordering, please give complete nameplate data of the valve and/or control being repaired.
MINIMUM ORDER CHARGE APPLIES.

Repair Kits for 100-02/100-21 Powertrol and 100-03/100-22 Powercheck Main Valves

For: Powertrol and Powercheck Main Valves—125/150 Pressure Class Only

Includes: Diaphragm, Disc (or Disc Assembly) and O-rings and full set of spare Spacer Washers.

Valve Size	Kit Stock Number 100-02	Valve Size	Kit Stock Number	
			100-02 & 100-03	100-21 & 100-22
3/8"	9169901H	2 1/2"	9169910J	N/A
1/2" & 3/4"	9169902F	3"	9169911G	9169905J
1"	9169903D	4"	9169912E	9169911G
1 1/4" & 1 1/2"	9169904B	6"	9169913C	9169912E
2"	9169905J	8"	99116G	9169913C
		10"	9169939H	99116G
		12"	9169937B	9169939H

Repair Kits for 100-04/100-23 Hy-Check Main Valves

For: Hy-Check Main Valves—125/150 Pressure Class Only

Larger Sizes: Consult Factory.

Includes: Diaphragm, Disc and O-Rings and full set of spare Spacer Washers.

Valve Size	Kit Stock Number		Valve Size	Kit Stock Number	
	100-04	100-23		100-04	100-23
4"	20210901B	N/A	12"	20210905H	20210904J
6"	20210902A	20210901B	14"	20210906G	N/A
8"	20210903K	20210902A	16"	20210907F	20210905H
10"	20210904J	20210903K	20"	N/A	20210907F
			24"	N/A	20210907F

Repair Kits for Pilot Control Valves (In Standard Materials Only)

Larger Sizes: Consult Factory.

Includes: Diaphragm, Disc (or Disc Assembly), O-Rings, Gaskets or spare Screws as appropriate.

BUNA-N® (Standard Material)				VITON (For KB Controls)	
Pilot Control	Kit Stock Number	Pilot Control	Kit Stock Number	Pilot Control	Kit Stock Number
CDB	9170006C	CFM-7	1263901K	CDB-KB	9170012A
CDB-30	9170023H	CFM-7A	1263901K	CRA-KB	N/A
CDB-31	9170024F	CFM-9	12223E	CRD-KB (w/bucking spring)	9170008J
CDB-7	9170017K	CRA (w/bucking spring)	9170001D	CRL-KB	9170013J
CDH-2	18225D	CRD (w/bucking spring)	9170002B	CDHS-2BKB	9170010E
CDHS-2	44607A	CRD (no bucking spring)	9170003K	CDHS-2FKB	9170011C
CDHS-2B	9170004H	CRD-18	20275401K	CDHS-18KB (no bucking spring)	9170009G
CDHS-2F	9170005E	CRD-22	98923G	102C-KB	1726202D
CDHS-3C-A2	24657K	CRL (55F, 55L)	9170007A		
CDHS-8A	2666901A	CRL-4A	43413E		
CDHS-18	9170003K	CRL-5 (55B)	65755B		
CDS-4	9170014G	CRL-5A (55G)	20666E		
CDS-5	14200A	CRL-18	20309801C		
CDS-6	20119301A	CV	9170019F		
CDS-6A	20349401C	X105L (O-ring)	00951E	Buna-N®	
CFCM-M1	1222301C	102B-1	1502201F	CRD Disc Ret. (Solid)	C5256H
CFM-2	12223E	102C-2	1726201F	CRD Disc Ret. (Spring)	C5255K
		102C-3	1726201F		

Repair Assemblies (In Standard Materials Only)

Control	Description	Stock Number
CF1-C1	Pilot Assembly Only	89541H
CF1-CI	Complete Float Control less Ball and Rod	89016A
CFC2-C1	Disc, Distributor and Seals	2674701E
CSM 11-A2-2	Mechanical Parts Assembly	97544B
CSM 11-A2-2	Pilot Assembly Only	18053K
33A 1"	Complete Internal Assembly and Seal	2036030B
33A 2"	Complete Internal Assembly and Seal	2040830J

When ordering, please give complete nameplate data of the valve and/or control being repaired. MINIMUM ORDER CHARGE APPLIES