

## CLA-VAL SURGE CONTROL VALVES

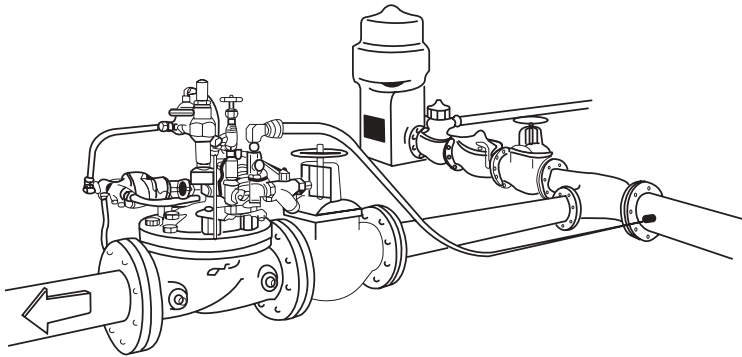

- Pipeline Protection due to Power Failure
- Valve Reacts Prior to High Surge Wave
- Simple Hydraulic Control no Electrical Needed

Surge Control Valves protect pumps and distribution systems from pressure waves caused by rapid changes in pipeline velocity. The gradual starting and stopping of pumps can't generate

harmful surges. However a power failure causes dangerous surges in the system which can damage equipment. Thus the control of surges in pumping systems is extremely important. The picture at left shows a typical installation. The surge control or surge anticipator valve is sized to protect the system by discharging to atmosphere. Usually a valve is selected that is one-third the line size or has the capacity to relieve one-third of the total pump output. Today's computer system models provide a much more detailed picture of pressure transients caused by a power failure. The following illustrations show graphically what the surge anticipator valve does when a power failure occurs.

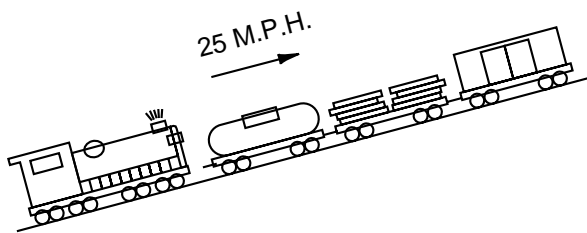

In illustration 1, a locomotive is pushing a train up a grade. This compares with a pump delivering water to a higher elevation through a pipeline

The locomotive has stopped abruptly in illustration 2 but the momentum carries the train forward up the grade. The same condition exists at the pump discharge upon power failure to the pump. The momentum of the water column continues to carry it forward, creating a low pressure wave at the pump discharge.

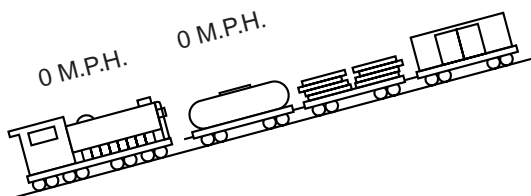
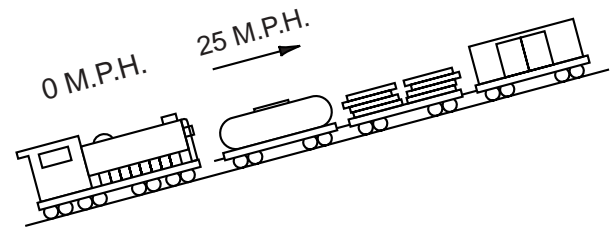
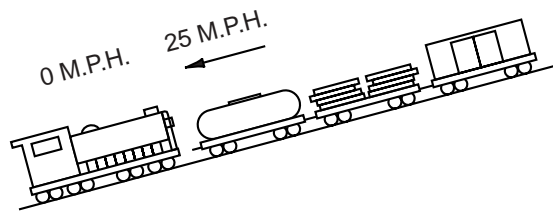

Illustration 3 shows the train stopped after expending its energy in moving up the grade. The water column in the pipeline has likewise come to rest.



The train, in illustration 4, has now started coasting backward down the track and is about to collide with the locomotive. The same is true in the pipeline, the water column reverses and flows back down the pipeline toward the pump with approximately the same velocity as before the pump failed.

In illustration 5 the moving train collides with the stationary locomotive with disastrous results. When the water returning back down the pipeline is stopped by the closed system check valve, a high pressure wave develops. The sudden stopping of the pump can be damaging to the pipeline and the pumping equipment, similar to the wrecked train. The magnitude of the high pressure surge is directly proportional to the rate of change of the velocity of the fluid. A 50-PSI surge will occur for each ft/sec change in the velocity of the fluid. A surge anticipator valve can control the high pressure at the check valve.

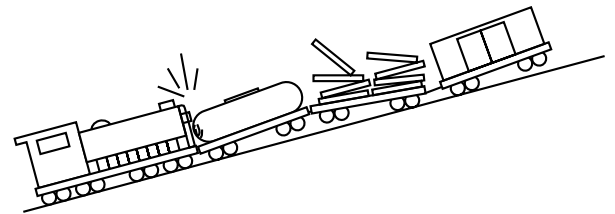
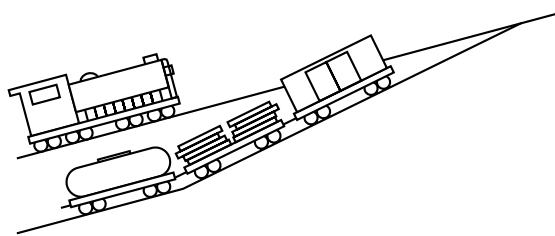

Illustration 6 shows the returning train being switched to a sidetrack, averting collision with the locomotive. A surge anticipator valve, acts in the same manner as the side-track and the train, directing the surge to atmosphere, protecting the pump and the system. Illustration 2 mentioned the creation of a low pressure wave. This was the result of the abrupt stopping of the pump and the water column rushing away from it. The surge anticipator senses the low pressure wave, then opens. This prevents the high pressure wave from building up against a closed system check valve. Eliminating damage to the pump



and system. This type of action is how the valve derives its name. Anticipating the high pressure wave and effortlessly bypassing it from the system.

## CLA-VAL

PO Box 1325 Newport Beach CA 92659-0325

800-942-6326 • Fax: 949-548-5441 • Web Site: [cla-val.com](http://cla-val.com) • E-mail: [claval@cla-val.com](mailto:claval@cla-val.com)

### CLA-VAL CANADA

4687 Christie Drive  
Beamsville, Ontario  
Canada LOR 1B4  
Phone: 905-563-4963  
Fax: 905-563-4040  
E-mail [sales@cla-val.ca](mailto:sales@cla-val.ca)

### CLA-VAL EUROPE

Chemin des Mésanges 1  
CH-1032 Romanel/  
Lausanne, Switzerland  
Phone: 41-21-643-15-55  
Fax: 41-21-643-15-50  
E-mail: [cla-val@cla-val.ch](mailto:cla-val@cla-val.ch)

### CLA-VAL UK

Dainton House, Goods Station Road  
GB - Tunbridge Wells  
Kent TN1 2 DH England  
Phone: 44-1892-514-400  
Fax: 44-1892-543-423  
E-mail: [info@cla-val.co.uk](mailto:info@cla-val.co.uk)

### CLA-VAL FRANCE

Avenue des Prés Seigneurs  
ZI de Dagneux - 01120  
Dagneux, France  
Phone: 33-4-72-25-92-93  
Fax: 33-4-72-25-04-17  
E-mail: [cla-val@cla-val.fr](mailto:cla-val@cla-val.fr)