

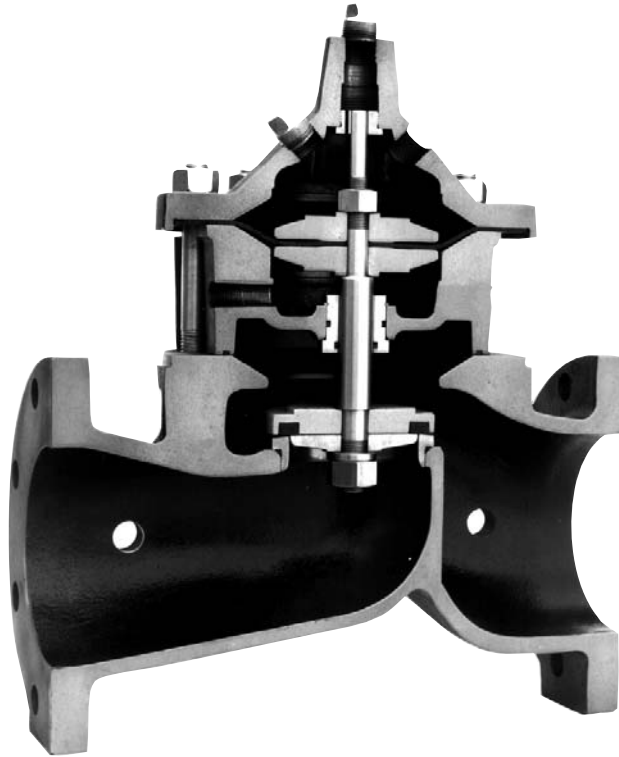

— MODEL — **100-21**
 (Reduced Internal Port)
600 Series
Powertrol Valve



- **Reduced Cavitation Design**
- **Drip-tight, Positive Seating**
- **Service Without Removal From Line**
- **Globe or Angle Pattern**
- **Every Valve Factory-Tested**

The Cla-Val Model 100-21 is a hydraulically operated, diaphragm actuated, globe or angle pattern valve. It consists of four major components: the body, intermediate chamber, diaphragm assembly and cover. The diaphragm assembly is the only moving part.

The diaphragm assembly, which is guided top and center by a precision machined stem, utilizes a non-wicking diaphragm of nylon fabric bonded with synthetic rubber. The diaphragm forms a seal between the cover chamber and intermediate chamber. A synthetic rubber disc retained on three and one-half sides forms a drip-tight seal with the renewable seat when pressure is applied above the diaphragm. As pressure above the diaphragm is relieved and pressure is applied below the diaphragm, the valve opens wide for full flow. The rate of closing or opening can be controlled by modulating the pressure above or below the diaphragm.

The Model 100-21 is recommended where independent operating pressure is desired. The valve's packless construction and simplicity of design assures a long life and dependable operation. Available in various materials and in a wide range of sizes. Its applications are many and varied.

Principle of Operation

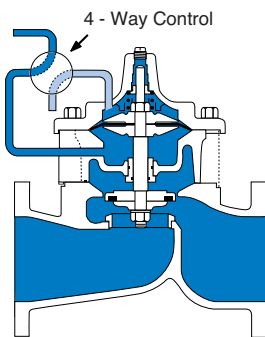

Full Open Operation

When operating pressure below the diaphragm is greater than the pressure in the cover chamber, the valve is held open, allowing full flow.

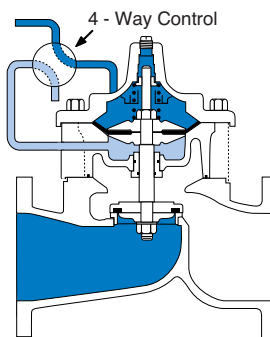

Tight Closing Operation

When pressure below the diaphragm is relieved and operating pressure is applied to the cover chamber, the valve closes drip-tight.

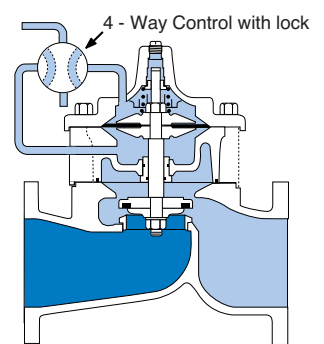

Modulating Action

The valve holds any intermediate position when operating pressure is equal above and below the diaphragm. A Cla-Val four-way pilot control with "lock" position can maintain this balance by stopping flow in the pilot control system.



Available Sizes

Pattern	Flanged
Globe	3", 4", 6", 8", 10", 12", 14", 16", 18", 20", 24", 30"
Angle	4", 6", 8"

Operating Temp. Range

Fluids
-40° to 180° F

Pressure Ratings (Recommended Maximum Pressure - psi)

Valve Body & Cover		Pressure Class		
		Flanged		
Grade	Material	ANSI Standards*	150 Class	300 Class
ASTM A536	Ductile Iron	B16.42	250	400
ASTM A216-WCB	Cast Steel	B16.5	285	400
ASTM B62	Bronze	B16.24	225	400

Note: * ANSI standards are for flange dimensions only.
Flanged valves are available faced but not drilled.
Valves for higher pressure are available; consult factory for details

Materials

Component	Standard Material Combinations		
Body & Cover	Ductile Iron	Cast Steel	Bronze
Available Sizes	3" - 30"	3" - 16"	3" - 16"
Disc Retainer & Diaphragm Washer	Cast Iron	Cast Steel	Bronze
Trim: Disc Guide, Seat & Cover Bearing	Bronze is Standard Stainless Steel is optional		
Disc	Buna-N® Rubber		
Diaphragm	Nylon Reinforced Buna-N® Rubber		
Stem, Nut & Spring	Stainless Steel		

For material options on sizes not listed, consult factory.
Cla-Val manufactures valves in more than 50 different alloys.

Options

Epoxy Coating - suffix KC

An FDA approved fusion bonded epoxy coating for use with cast iron, ductile iron or steel valves. This coating is resistant to various water conditions, certain acids, chemicals, solvents and alkalies. Epoxy coatings are applied in accordance with AWWA coating specifications C116-03. Do not use with temperatures above 175°F.

Viton® Rubber Parts - suffix KB

Optional diaphragm, disc and o-ring fabricated with Viton® synthetic rubber. Viton® is well suited for use with mineral acids, salt solutions, chlorinated hydrocarbons, and petroleum oils; and is primarily used in high temperature applications up to 250° F. Do not use with epoxy coating above 175°F.

Heavy Spring - suffix KH

The heavy spring option is used in applications where there is low differential pressure across the valve, and the additional spring force is needed to help the valve close. This option is best suited for valves used in on-off (non-modulating) service.



4" Globe, Flanged



6" Globe, Flanged



6" Angle, Flanged

For assistance in selecting appropriate valve options or valves manufactured with special design requirements, please contact our Regional Sales Office or Factory.

Valve Size		Inches	3	4	6	8	10	12	14	16	18	20	24	30
		mm.	80	100	150	200	250	300	350	400	460	510	610	750
C_V Factor	Globe Pattern	Gal./Min. (gpm.)	62	136	229	480	930	1458	1725	2110	2940	3400*	3500*	7900*
		Litres/Sec. (l/s.)	15	32.5	55	115	223	350	414	506	705	816	840	1895
	Angle Pattern	Gal./Min. (gpm.)	—	135	233	545	—	—	—	—	—	—	—	—
		Litres/Sec. (l/s.)	—	32	56	132	—	—	—	—	—	—	—	—
Equivalent Length of Pipe	Globe Pattern	Feet (ft.)	293	251	777	748	621	654	750	977	983	1125	3005	2130
		Meters (m.)	89.3	76.4	237.1	228.1	189.5	199.4	228.7	298.1	299.9	343.2	916.6	649.6
	Angle Pattern	Feet (ft.)	—	254	751	580	—	—	—	—	—	—	—	—
		Meters (m.)	—	77.6	229	176.9	—	—	—	—	—	—	—	—
K Factor	Globe Pattern		20.6	12.7	23.1	15.7	10.4	8.5	8.9	10.2	8.4	8.8	19.1	10.5
	Angle Pattern		—	12.9	22.3	12.2	—	—	—	—	—	—	—	—
Liquid Displaced from Diaphragm Chamber When Valve Opens	Fl. Oz		—	—	—	—	—	—	—	—	—	—	—	—
	U.S. Gal.		.032	.08	.17	.53	1.26	2.51	4	4	9.6	9.6	9.6	29.0
	ml		—	—	—	—	—	—	—	—	—	—	—	—
	Litres		.12	.30	.64	2.0	4.8	9.5	15.1	15.1	36.2	36.2	36.2	110

*Estimated

C_V Factor

Formulas for computing C_V Factor, Flow (Q) and Pressure Drop (ΔP):

$$C_V = \frac{Q}{\sqrt{\Delta P}} \quad Q = C_V \sqrt{\Delta P} \quad \Delta P = \left(\frac{Q}{C_V} \right)^2$$

K Factor (Resistance Coefficient)

The Value of K is calculated from the formula: $K = \frac{894d^4}{C_V^2}$ (U.S. system units)

Equivalent Length of Pipe

Equivalent lengths of pipe (L) are determined from the formula: $L = \frac{Kd}{12f}$ (U.S. system units)

Fluid Velocity

Fluid velocity can be calculated from the following formula: $V = \frac{.4085 Q}{d^2}$ (U.S. system units)

Where:

C_V = U.S. (gpm) @ 1 psi differential at 60° F water
or
= (l/s) @ 1 bar (14.5 PSIG) differential at 15° C water

d = inside pipe diameter of Schedule 40 Steel Pipe (inches)

f = friction factor for clean, new Schedule 40 pipe (dimensionless) (from Cameron Hydraulic Data, 18th Edition, P 3-119)

K = Resistance Coefficient (calculated)

L = Equivalent Length of Pipe (feet)

Q = Flow Rate in U.S. (gpm) or (l/s)

V = Fluid Velocity (feet per second) or (meters per second)

ΔP = Pressure Drop in (psi) or (bar)

Model 100-21 Flow Chart (Based on normal flow through a wide open valve)

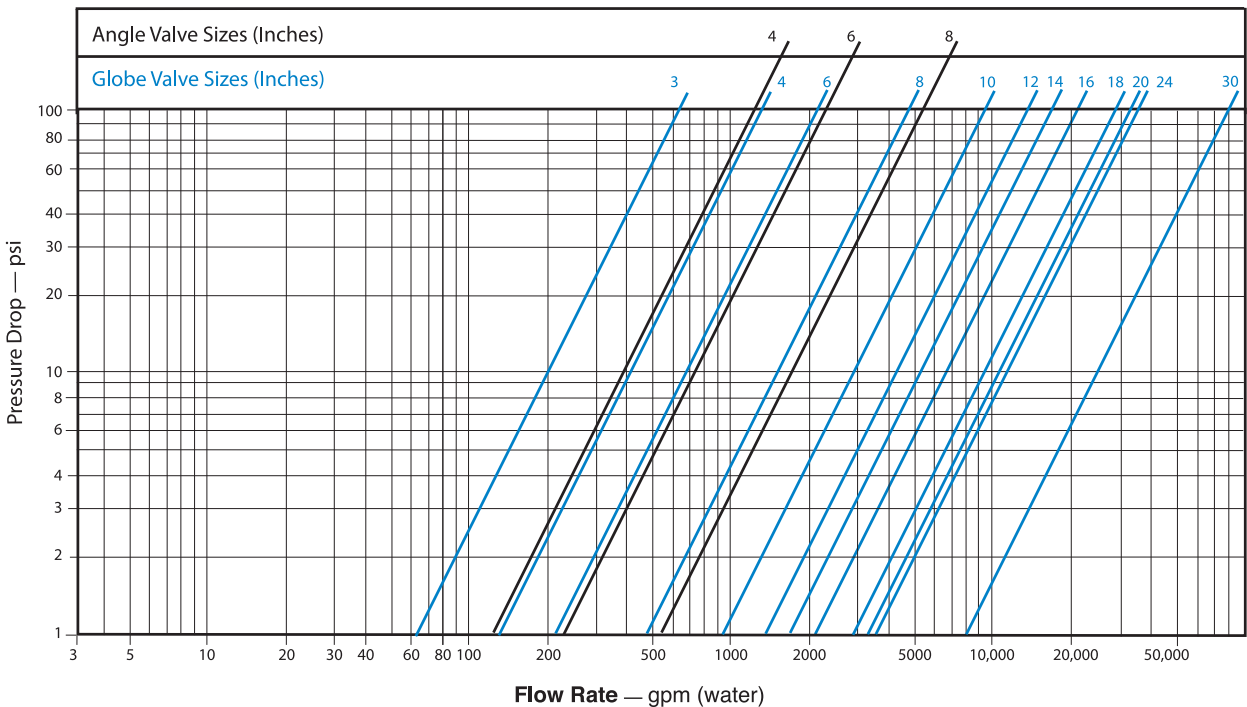

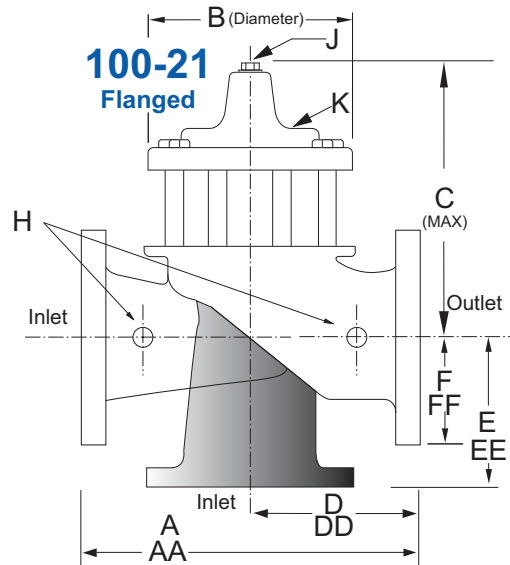

Valve Size (Inches)	3	4	6	8	10	12	14	16	18	20	24	30
A 150 ANSI	10.25	13.88	17.75	21.38	26.00	30.00	34.25	35.00	42.12	48.00	48.00	63.25
AA 300 ANSI	11.00	14.50	18.62	22.38	27.38	31.50	35.75	36.62	43.62	49.62	49.75	—
B Dia.	6.62	9.12	11.50	15.75	20.00	23.62	28.00	28.00	35.44	35.44	35.44	53.19
C Max.	9.25	11.75	15.25	20.25	23.75	27.25	29.31	34.12	35.00	40.25	40.25	56.50
D 150 ANSI	—	6.94	8.88	10.69	—	—	—	—	—	—	—	—
DD 300 ANSI	—	7.25	9.38	11.19	—	—	—	—	—	—	—	—
E 150 ANSI	—	5.50	6.75	7.25	—	—	—	—	—	—	—	—
EE 300 ANSI	—	5.81	7.25	7.75	—	—	—	—	—	—	—	—
F 150 ANSI	3.25	4.50	5.50	6.75	8.00	9.50	11.00	11.75	15.88	14.56	17.00	19.88
FF 300 ANSI	4.12	5.00	6.25	7.50	8.75	10.25	—	12.75	15.88	16.06	19.00	—
H NPT Body Tapping	.375	.50	.75	.75	1	1	1	1	1	1	1	1
J NPT Cover Center Plug	.50	.50	.75	.75	1	1	1.25	1.25	2	2	2	2
K NPT Cover Tapping	.375	.50	.75	.75	1	1	1	1	1	1	1	1
Valve Stem Internal Thread UNF	10-32	¼-28	¼-28	¾-24	¾-24	¾-24	¾-24	¾-24	½-20	½-20	½-20	¾-16
Stem Travel	0.6	0.8	1.1	1.7	2.3	2.8	3.4	3.4	3.4	4.5	4.5	6.5
Approx. Ship Wt. Lbs.	70	135	230	480	785	1410	2215	2215	2300	3400	3600	7700

Valve Size (mm)	80	100	150	200	250	300	350	400	450	500	600	750
A 150 ANSI	260	353	451	543	660	762	870	889	1070	1219	1219	1607
AA 300 ANSI	279	368	473	568	695	800	908	930	1108	1260	1264	—
B Dia.	168	232	292	400	508	600	711	711	900	900	900	1351
C Max.	235	298	387	514	603	692	744	867	889	1022	1022	1435
D 150 ANSI	—	176	226	272	—	—	—	—	—	—	—	—
DD 300 ANSI	—	184	238	284	—	—	—	—	—	—	—	—
E 150 ANSI	—	140	171	184	—	—	—	—	—	—	—	—
EE 300 ANSI	—	148	184	197	—	—	—	—	—	—	—	—
F 150 ANSI	95	114	140	171	203	241	279	298	403	370	432	505
FF 300 ANSI	105	127	159	191	222	260	—	324	403	408	483	—
H NPT Body Tapping	¾	½	¾	¾	1	1	1	1	1	1	1	1
J NPT Cover Center Plug	½	½	¾	¾	1	1	1¼	1¼	2	2	2	2
K NPT Cover Tapping	¾	½	¾	¾	1	1	1	1	1	1	1	1
Valve Stem Internal Thread UNF	10-32	¼-28	¼-28	¾-24	¾-24	¾-24	¾-24	¾-24	½-20	½-20	½-20	¾-16
Stem Travel	15	20	28	43	58	71	86	86	86	114	114	165
Approx. Ship Wt. Kgs	32	61	104	218	356	640	1006	1006	1044	1544	1634	3496

Service and Installation

Cla-Val Control Valves operate with maximum efficiency when mounted in horizontal piping with the main valve cover UP, however, other positions are acceptable. Due to component size and weight of 10 inch and larger valves, installation with cover UP is advisable. We recommend isolation valves be installed on inlet and outlet for maintenance. Adequate space above and around the valve for service personnel should be considered essential. A regular maintenance program should be established based on the specific application data. However, we recommend a thorough inspection be done at least once a year. Consult factory for specific recommendations.