

Valve Flow Measurement

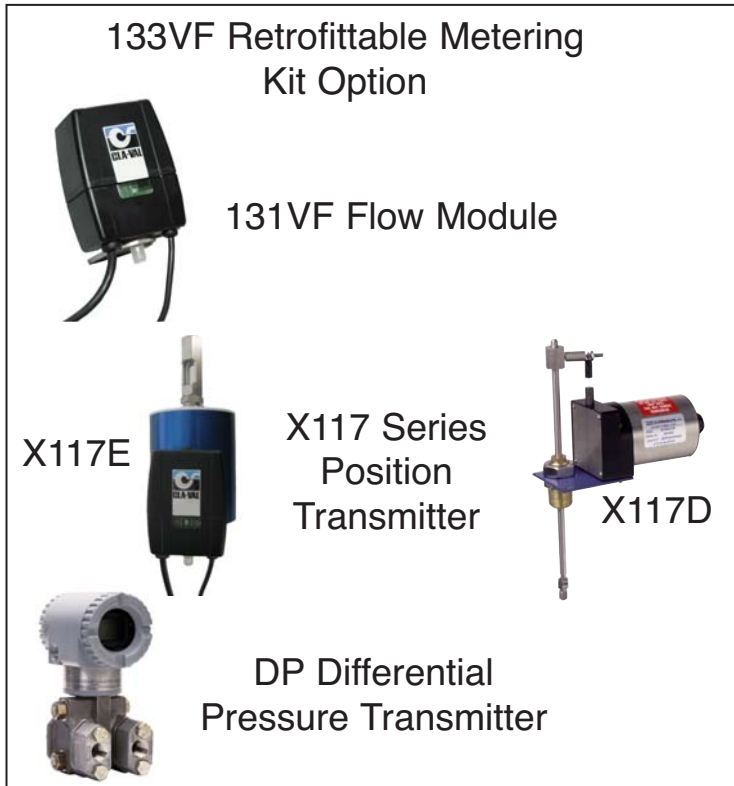

- System accurately measures flow rate
- No external meter is required
- For new installations and retrofitting existing valves
- Completely self-contained, requiring 12 to 24 VDC power
- Simple integration

The Cla-Val 133VF Flow Metering System is an effective means of obtaining real-time flow data from a Cla-Val control valve regardless of valve function and without an external flow device. Now all Cla-Val control valves in a water distribution system can be economically integrated into SCADA control or pressure and flow management strategies.

The 133VF System is completely self-contained and when factory installed on new Cla-Val automatic control valves or field installed on existing valves, accurately measures flow rate and transmits it as a 4 - 20 mA analog signal. It can be used on virtually all valve sizes from two through twenty-four inch and is typically used at pressure reducing, back pressure, flow limiting, and level control valve stations.

The 131VF flow module accepts 4-20 mA analog signals of valve differential pressure and valve position to determine the flow rate.

The partially-open valve Cv is derived from valve position then used to calculate flow rate with formula shown below:

Where:

$$Q = C_v \sqrt{DP / SG}$$

Q = flow (gpm)
 DP = differential pressure (psi)
 SG = specific gravity of fluid (water = 1.0)

The system features the “heart” of the 133-01 Flow Metering Control Valve technology and adapts it for single-valve flow monitoring-only applications. The 133VF System major components are an X117D valve position transmitter, a differential or inlet and outlet pressure transmitters and a 131VF flow calculating module. All components are 24 VDC powered and weather protected to IP-68 submersible rating. The 131VF module, with standard DIN rail mounting, contains powerful mini-computer technology for calculating valve flow based on inputs from the sensors and using the appropriate flow curve for a particular Cla-Val valve. For increased accuracy the 131VF module uses third-party certified flow curves tested for this particular metering application. Valve differential pressure measurement can be located either at the valve inlet and outlet bosses or on pipe adjacent to the valve providing installation versatility in all applications and operating conditions.



For applications requiring flow measurement and remote set point control, see 133-01 Metering Valve catalog data sheet.

133VF System Using Differential Pressure Sensing

Typical 133VF System installation where the differential pressure transmitter is valve mounted. As the pressure reducing valves transition between low flow and high flow conditions, SCADA operators can monitor valve flow rates to determine the most efficient operation of the pressure reducing station. Provide for adequate protection from lightning strikes.

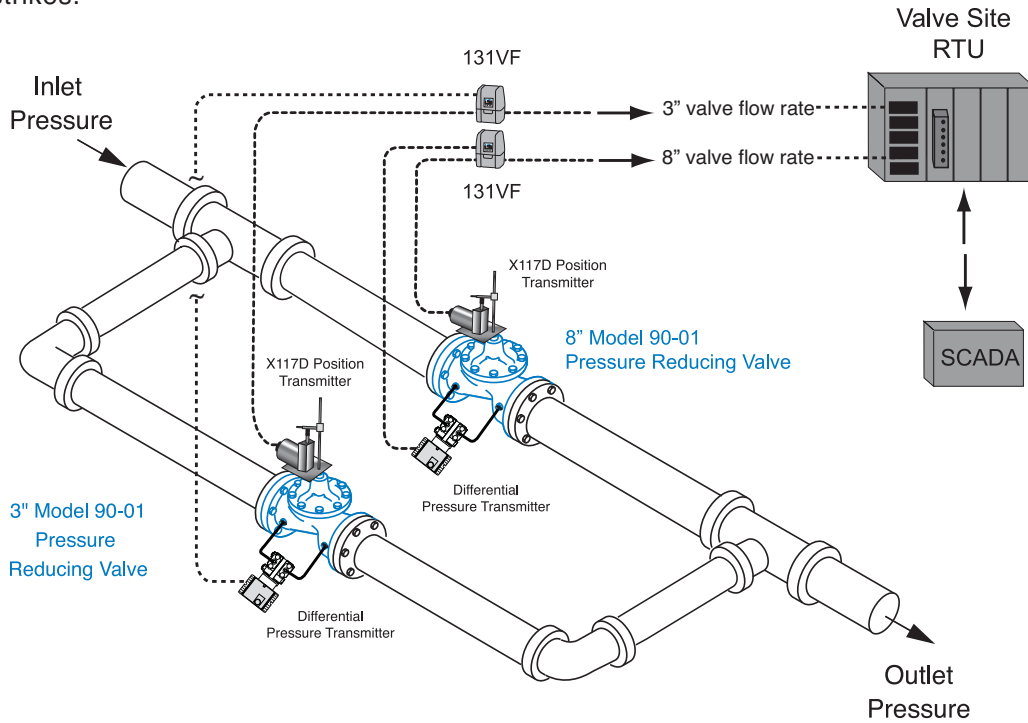

Wiring Diagram

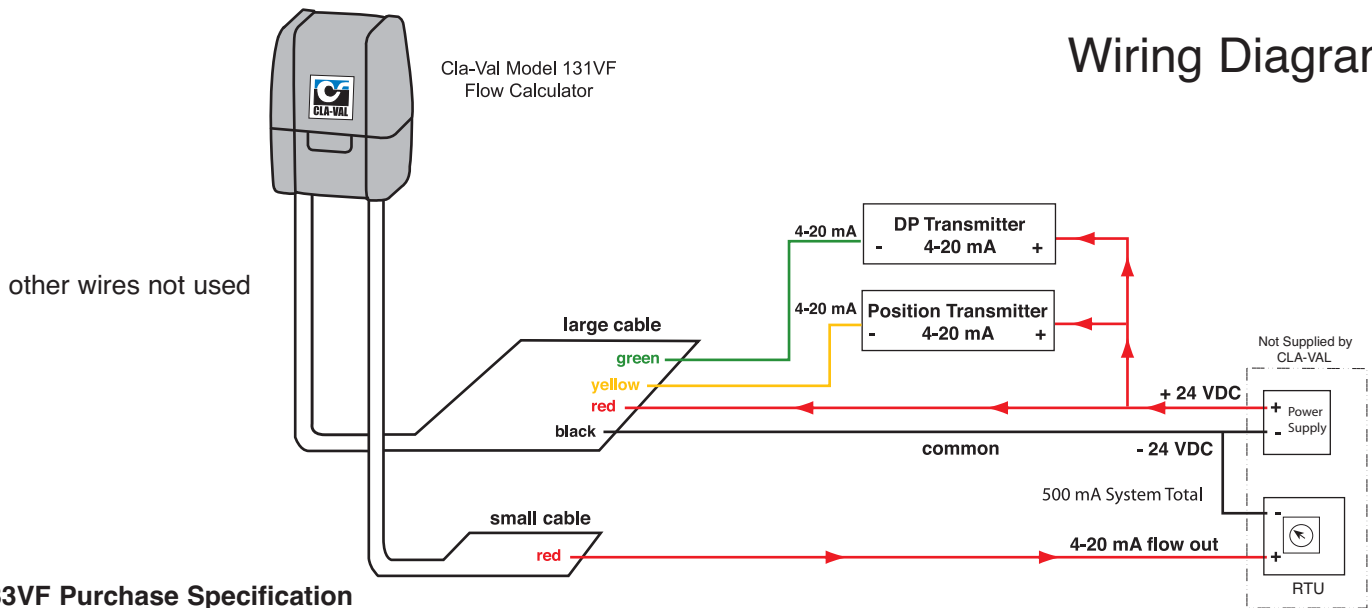

133VF Purchase Specification

The model 133VF Valve Flow Measurement System shall be specified and installed on a new or existing valve with "KVF" suffix letters inserted after the model number of Cla-Val standard hydraulic control valve (i.e.: 90-01AB-KVF) and shall be capable of calculating flow in common measurement units. It shall use a valve mounted position transmitter rated NEMA type 6P for temporary submersible operation that shall track valve position from 0 to 100%. It shall also be equipped with a differential pressure transmitter or an inlet and outlet pressure transmitter with a NEMA 4X rating and shall have infinite ranging ability. The transmitters shall also be capable of being zeroed in the field to compensate for elevation and temperature changes. Information from these transmitters shall be assimilated into a flow module capable of computing flow when the pressure differential is measured at the body bosses of the control valve or on the pipeline if located within three pipe diameters of the control valve. Flow Module power shall be 24VDC not to exceed 150 mA current draw. The flow module shall output a 4-20mA flow signal. All power to operate the foregoing equipment shall be supplied by others.

The Valve Flow Measurement System shall be similar in all respects to the model 133VF. Please see back page for additional ordering information and model number detail to insert after the KVF suffix.

133VF System Using Inlet & Outlet Pressure Sensing

Typical 133VF System installation where two pressure transmitters are used upstream and downstream of the valve. The 131VF module will calculate pressure differential from these two sensors. When inlet and outlet pressure values are to be sent to RTU, then loop isolators should be installed on the 4 - 20 mA signals going to SCADA and the 131VF. Provide for adequate protection from lightning strikes.

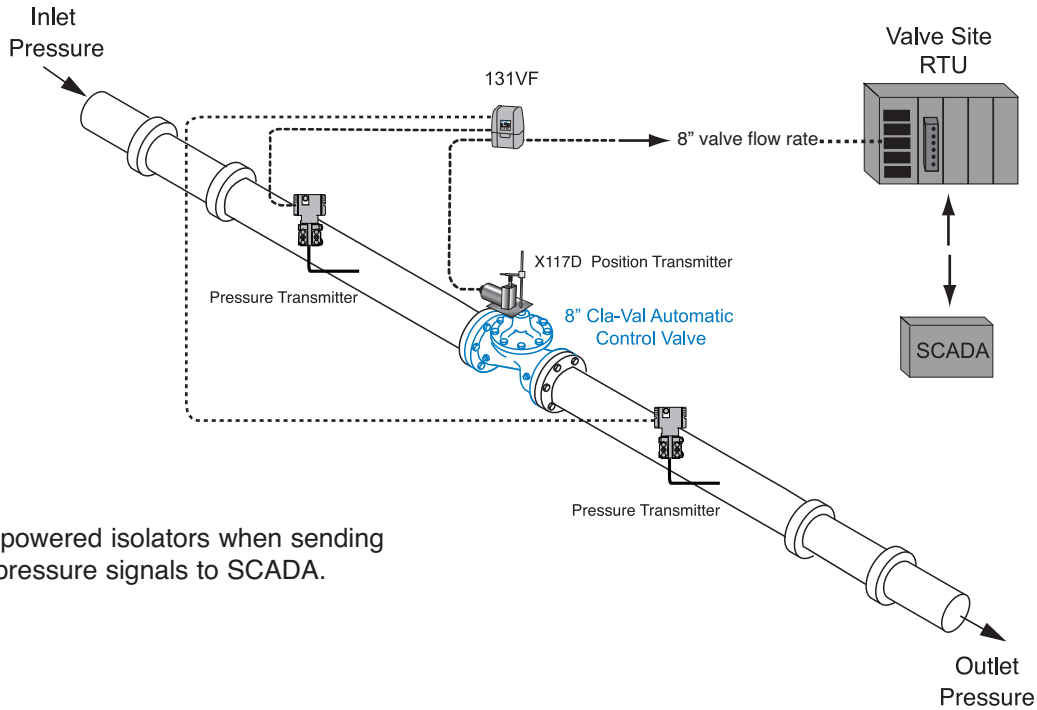

Use loop powered isolators when sending 4-20 mA pressure signals to SCADA.

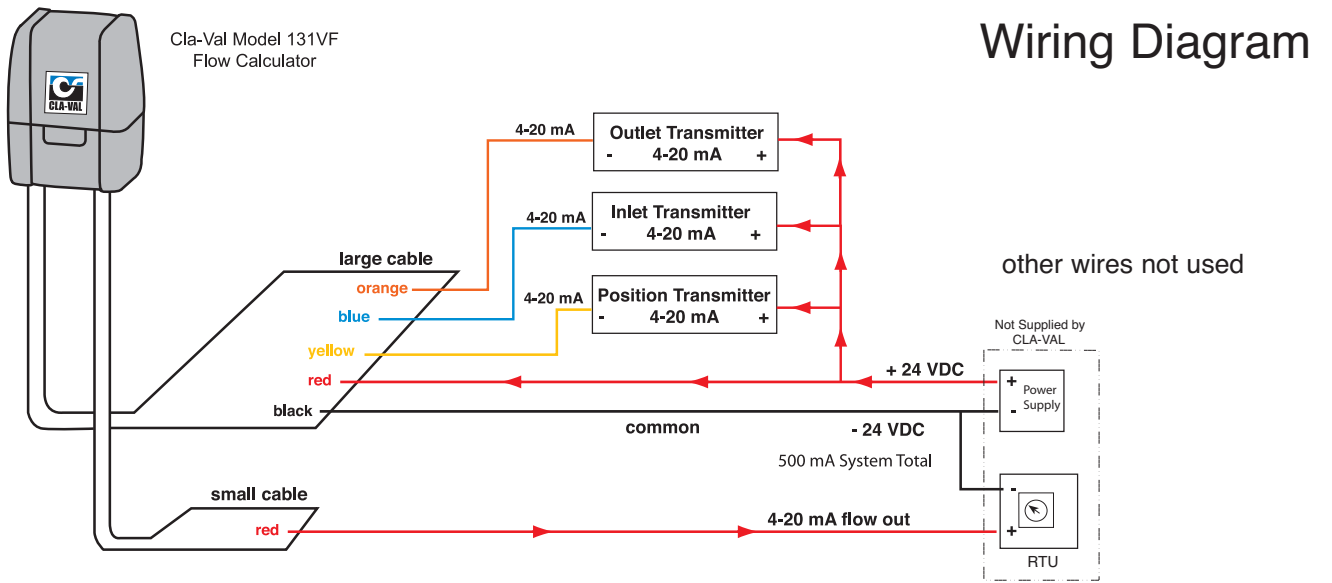

Visit www.cla-val.com to learn more about Cla-Val's extensive line of electronic control valves and ancillary products.

CLA-VAL 133VF System Ordering

Model Number 133VF-

Product Type

- K. Kit to install on existing valve
- N. Install on a new valve

Main Valve Selection

Valve Size

Indicate valve size 2" thru 24"

Valve Type

- F. Full port
- R. Reduced port

Valve Pattern

- G. Globe pattern
- A. Angle pattern

Valve Trim

- S. Standard
- A. Anti-Cavitation

Component Selection

131VF Module Mounting

- D. DIN rail (Standard)
- V. Valve mount
- N. None

Sensor Type

- D. DP transmitter (qty 1)
- P. Pressure transmitters (qty 2)
- N. None

Tubing & Fittings for DP Sensor

- C. Copper (Standard)
 - S. Stainless Steel
- (Three CK2 isolation valves included)

Sensor Mounting

- L. Left side (Standard)
- R. Right side
- N. None

X117D Position Transmitter

Options

- N. None (Already installed)
- O. with One limit switch
- T. with Two limit switches

Special Options

- N. None
 - KX. KX denotes extra or special configurations not listed above.
- Contact your local Cla-Val representative for assistance.

For new valves, please specify with the "KVF" suffix letters plus the 133VF model number added after valve model number.

Example:

90-01BY KVF - 133VF-N-6FGS-VPCLNN

↑
valve
model #

↑
133VF model #

When ordering 133VF system, in addition to model number specify:

1. Analog output signal flow scale (i.e. - Output Flow: 0 to 1000 GPM). Must be suitable to valve capacity and system capabilities.
2. Input pressure sensor type (DPT or P1-P2) and full scale output @20mA (P1 and P2 must have same scale.)

Note: Cla-Val supplied DPT have standard scale of 0 to 100 psid.

Accuracy and Calibration Recommendations

All sensors must be calibrated for best accuracy. In addition, the differential pressure transmitter must be set to the correct range. Typical accuracy is within 2 to 3% actual flow. Accuracy may be less than this if:

- Valve position is less than 5%
- Sensors are not calibrated or zeroed
- Incorrect range of differential pressure transmitter
- Valve is corroded
- Inlet & outlet are not full pipe flow
- Valve pressure differential less than 1 psid

131VF Specifications

Enclosure: 2" x 3" x 4", Non-Metallic IP-68 Rated

Power Requirement: 24VDC, 150 mA

Flow Signal Output: 4-20 mA analog unpowered

System Total Power Requirement: 24VDC, 500 mA

PO Box 1325 Newport Beach, CA 92659-0325 • www.cla-val.com • Ph: 949-722-4800 • Fax: 949-548-5441

CLA-VAL CANADA

4687 Christie Drive
Beamsville, Ontario • Canada L0R 1B4
Ph: 905-563-4963 • Fax: 905-563-4040 • www.cla-val.ca



CLA-VAL EUROPE

Chemin des Mesanges 1
CH-1032 Romanel/Lausanne, Switzerland • www.cla-val.ch
Ph: 41-21-643-15-55 • Fax: 41-21-643-15-50