

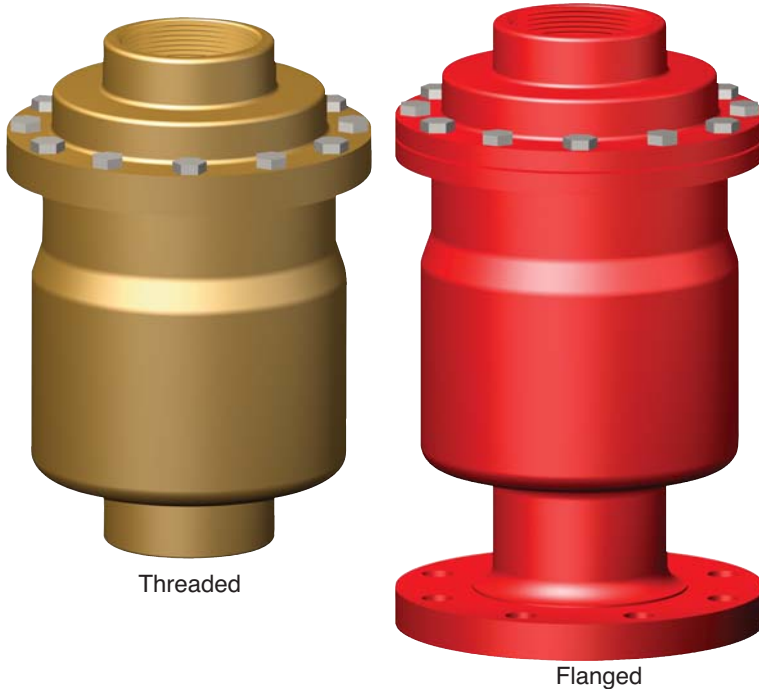

# Series 33A

Sizes 1" - 2" - 3" - 4" - 6"

## Air Release & Vacuum Breaker Valve (Threaded & Flanged)



- Automatically Eliminates Air Pockets
- Easily Serviced Without Removal from Pipeline
- Simple, Effective Patented Design
- Corrosion Resistant Materials of Construction
- Engineered For Lasting Service

Designed to protect pipelines and vertical turbine pump applications on offshore platforms from air lock and vacuum collapse, the Cla-Val Model 33A Air Release and Vacuum Breaker Valve eliminates air and prevents vacuum formations in pipelines. A large venting orifice and large float clearances freely exhaust or admits air during pipeline filling or draining.

During normal pipeline operation, air accumulation and buoyancy cause the float ball to lower or lift. As the water level lowers inside the valve, small amounts of accumulated air are released through the small orifice. Once air is released, the patented float poppet system closes drip tight.

Valve servicing is simple because the entire float poppet system, can be replaced without removal of the valve body from the pipeline.

### Typical Applications

- Standard Max. D.W.P. 300 psi (For Higher Operating Pressures Consult Factory)
- Transmission Pipeline High Points
- Water Treatment Plant Piping High Points
- Offshore Platforms
- Vertical Turbine Pump Discharge

### Installation

Series 33A Air Release and Vacuum Breaker Valves are typically installed at high points in pipelines for air release, or at anticipated pipeline vacuum occurrence locations. Install Series 33A at regular intervals (approximately 1/2 mile) along uniform grade line pipe. Mount the unit in the vertical position on top of the pipeline, and include an isolation/shutoff valve.

Series 33A is often installed upstream of check valves in pump discharges to vent air during start-up and to allow air reentry when the pump stops.

### Operation

#### Air Release Mode—Valve is normally open.

When line is filled or pump started, air is exhausted through the normally open 33A valve. As liquid fills the valve, float ball rises to form a drip-tight closure and remaining air is exhausted through small orifice.

**Vacuum Prevent Mode** When line pressure drops below positive pressure and the liquid level lowers, the float drops, unseating the valve and allowing air into the line, thus preventing a vacuum.

**Note:** Available for Sea Water Service See Material Specifications

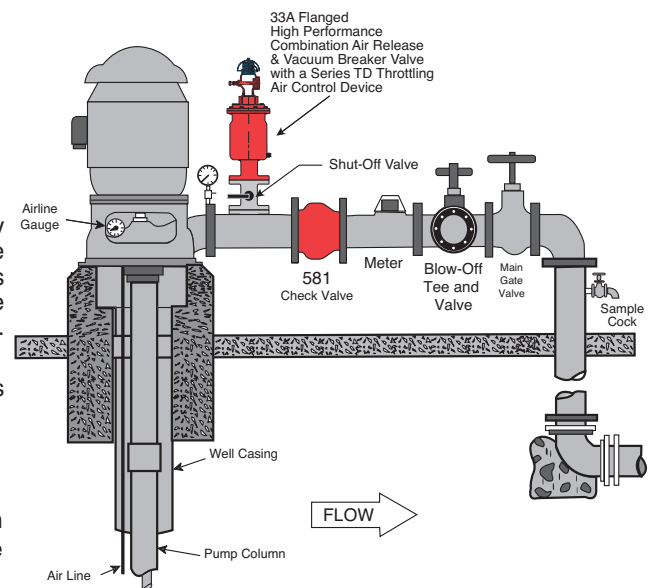

## Dimensions (In Inches)

## MODEL 33A - 1", 2", 3", 4" and 6" Sizes

Valve Size	33A Pressure Class 300 Lb Threaded				33A Pressure Class 150 Lb Flanged (INLET)			
	1"	2"	3"	4"	2"	3"	4"	6"
A	9.10	13.50	12.75	12.75	13.88	15.56	15.75	16.38
B	6.25	7.50	9.00	9.00	7.50	9.25	9.25	11.00
E	—	—	—	—	.62	.75	.94	1.00
Inlet (ANSI)	1" NPT	2" NPT	3" NPT	4" NPT	2"	3"	4"	6"
Outlet (NPT)	1" NPT	2" NPT	3" NPT	4" NPT	2"	4"	4"	6"
Number of Holes	—	—	—	—	4	4	8	8
Diameter of Bolts	—	—	—	—	.63	.63	.75	.75
Shipping Wt. (Lb.)	25	29	38	40	39	48	50	70

### Pressure Ratings

Valve Size	Orifice Dia.	Standard Maximum Pressure	Materials of Construction
1"	.076"	300 psi	<ul style="list-style-type: none"> <li>Ductile Iron ASTM A536 65-45-12</li> <li>Epoxy Coated Cast Steel ASTM A 216WCB</li> </ul>
2"	.076"	300 psi	
3" & 4"	.125"	300 psi	<ul style="list-style-type: none"> <li>ASTM B61 Naval Bronze</li> <li>ASTM B 148 NI Aluminum Bronze</li> </ul>
3" & 4"	.076"	300 psi	<ul style="list-style-type: none"> <li>316 Stainless Steel</li> <li>Duplex Stainless Steel</li> </ul>
6"	.076"	300 psi	<ul style="list-style-type: none"> <li>Super Duplex Stainless Steel</li> </ul>

**Note:** Higher Pressures Available upon Request

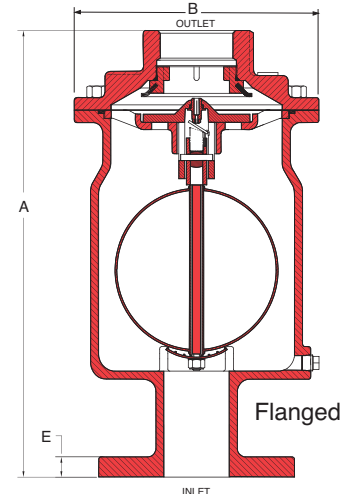
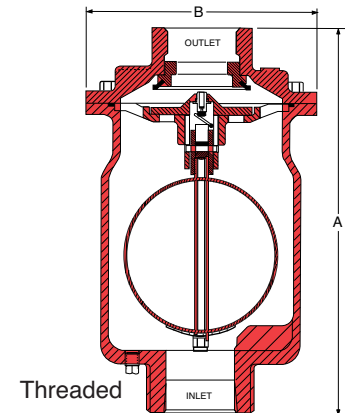

### Specifications

#### Standard Internals

Float: Stainless Steel 304SS Standard, T316 or Monel optional (extra cost)

Balance internals parts Stainless Steel and Delrin

Seals Nitrile Rubber or Viton® (extra cost)

#### When Ordering, Please Specify

1. Catalog No.
2. Valve Size
3. Pressure Rating
4. Materials

#### Temperature Range

Water to 180° F

#### Optional:

1. Fusion epoxy lined and coated
2. For Well Service Throttling Device on the Outlet Specify Model TD

### Valve Sizing Selection

#### Large Orifice Air-Vacuum Capacity

Determine anticipated water flow and allowable pressure differential for the pipeline application. Select valve from chart to exhaust or admit air at the same rate as water filling or draining (in CFS). For larger flows, two or more Model 33A's may be installed in parallel

#### Large Orifice

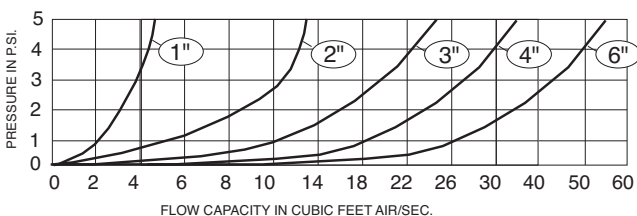

Note: For sizing made easy request:  
Cla-Val Selector Slide Rule

#### Small Orifice Capacity

During pressurized pipeline operation, small pockets of entrapped air will be released through the float actuated 0.076 or .125 inch orifice. Use chart to determine discharge capacity.

