



— MODEL — **98-01/698-01**

Kit Installation Instructions

The Cla-Val Model 98-01/698-01 kits are packaged to be retrofitted on valves in the field. Depending on the customers preferences the kits can replace the existing pilot system on the valve or in some cases kits can be installed without removing existing pilot hardware. The existing pilot hardware (typically a 90 series configuration) can remain intact as long as it is equipped with CK2 isolation valves to hydraulically disable the old pilot system. 98-01 kits are configured to use two of the body side bosses and one of the lateral cover bosses. These three ports must be available in order to properly install the kits. Kits can be ordered either in a left hand or right hand configuration. A right hand mounted 98-01 pilot system is shown in the below picture. Sharing ports with existing pilot plumbing is not recommended and may cause the valve to not operate properly.

Kits are available with either stainless steel tubing and fittings or copper tubing with brass fittings. All pipe, tubing and fittings are preformed. Copper tubing is the recommended standard for kits because it can be more easily manipulated during the kit installation process. Available 98-01/698-01 Kit P/N's are noted in the table on the last page.

When installing the X78 assemblies into the valve cover, care must be taken to insure the X78 stem is fully bottomed in the threaded hole of the main valve stem. The installation gap between the top of the main valve cover and the hex flats of the X78 adapter is also important. A spacer gage is supplied with each kit to help with the proper installation of the X78 assemblies. The drawing on the right shows the location of the gap.

The below chart notes the proper gap dimensions for each valve size. Refer to these dimensions when assembling the X78 onto the valve cover.

VALVE SIZE	SPACER GAGE P/N	GAP DIMENSION	A DIMENSION
2"	206795-01B	.25"	1.06"
3"	206795-02A	.25"	1.42"
4"	206795-02A	.35"	2.07"
6"	206795-02A	.35"	2.78"
8"	206795-03K	.46"	3.28"
10"	206795-03K	.46"	3.62"
12"	206795-04J	.46"	4.62"

Recommended Assembly Steps:

1. Isolate main valve from system during 98-01 kit assembly. This step is usually accomplished by closing isolation valves upstream and downstream of the main valve. **CAUTION:** 98-01 kits cannot be assembled with system pressure at inlet and outlet valve ports.
2. Remove pipe plug from main valve cover and clean pipe threads. Remove plugs and/or fittings from valve side bosses and clean pipe threads.
3. Unscrew X78 Housing from X78 Adapter, exposing internal components of X78 assembly as shown in the picture on the right. Grab the X78 Stem and screw the Stem Coupling into the threads

of the main valve stem until the Stem Coupling is bottomed in the main valve stem. **CAUTION:** Using 7/16" hex flats on X78 Retainer to secure X78 Stem Coupling is not recommended. Excessive torque on this part can damage the X78 Retainer. Using vise grips or pliers on exposed surface area of X78 is the recommended assembly torque method.

4. After Stem Coupling is bottomed, screw Adapter into main valve cover until proper gap dimension is achieved. The proper gap dimension can be achieved using the Spacer Gage supplied with 98-01 kits. Screw the Adapter in until the hex flats bottom against the Spacer Gage.

5. Slide the X78 Housing with X101 Assembly and screw onto Adapter threads until bottomed. After X78 Housing is bottomed, remove the spacer gage and use a wrench on Adapter hex flats and continue to screw X78 Adapter into main valve cover until inlet port of X78 Assembly (lower port) is aligned with the main valve inlet port as shown in the picture of the 98-01 Assembly on the previous page.

6. Continue to assemble the other components of the 98-01 kit. The picture of the 98-01 Assembly can be used as a guideline for assembling the remaining components. All tubing and piping is preformed so their proper location is easily determined as the assembly process progresses.

7. After the 98-01 kit is assembled open all isolation valves

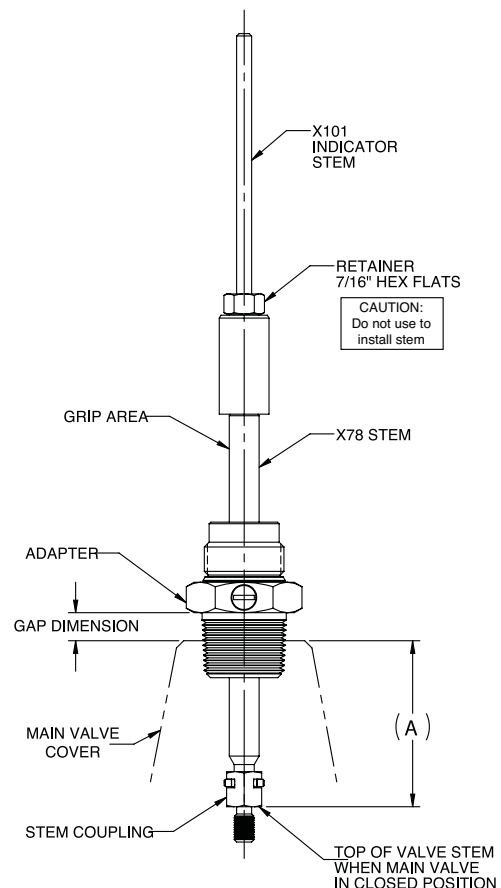

except for the isolation valve located at the outlet port. Slowly open the system isolation valve upstream of the valve inlet, allowing the main valve inlet and cover chambers to pressurize. Check for leaks in the pilot system and retighten accordingly. Open the system isolation valve downstream of the main valve inlet just enough to allow for a low flow condition to occur when the main valve opens. Open the isolation valve located at the outlet port. This action will activate the main valve causing it to open to the factory settings of the CRD2S Pressure Management Control Pilot.

CAUTION: The system downstream isolation valve should only be partially open prior to adjusting the controls on the 98-01 pilot system. This step is recommended to prevent the possibility of

over pressurizing the system before the 98-01 controls have been properly adjusted. The CRD2S has a nominal high pressure factory set point of 60 psi (4.1 Bar) and the low pressure adjustment screw is normally turned in (disabled). Actual factory adjustments can change during shipment and handling and/or during the kit assembly process.

8. Kit assembly is complete. Refer to Cla-Val schematic drawing 206510 for instructions on how to adjust and operate the 98-01/698-01 Pressure Management Control Valve.

Note: Refer to the N-98-01/698-01 for Startup Instructions

VALVE SIZE	98-01 KIT PART NUMBER	698-01 KIT PART NUMBER	KIT CONFIGURATION	
			TUBING & FITTINGS	MOUNTING ORIENTATION
2"	20666207F	—	316 SST	RIGHT HAND
	20666207F	—	316 SST	LEFT HAND
	20666201B	—	COPPER/BRASS	RIGHT HAND
	20666201B	—	COPPER/BRASS	LEFT HAND
3"	consult Factory	Consult Factory	316 SST	RIGHT HAND
	consult Factory	Consult Factory	316 SST	LEFT HAND
	20666202A	20666301A	COPPER/BRASS	RIGHT HAND
	20666202A	20666301A	COPPER/BRASS	LEFT HAND
4"	20666210A	Consult Factory	316 SST	RIGHT HAND
	20666210A	Consult Factory	316 SST	LEFT HAND
	20666203K	20666302K	COPPER/BRASS	RIGHT HAND
	20666203K	20666302K	COPPER/BRASS	LEFT HAND
6"	20666208E	Consult Factory	316 SST	RIGHT HAND
	20666208E	Consult Factory	316 SST	LEFT HAND
	20666204J	20666303J	COPPER/BRASS	RIGHT HAND
	20666204J	20666303J	COPPER/BRASS	LEFT HAND
8"	2066609D	Consult Factory	316 SST	RIGHT HAND
	2066609D	Consult Factory	316 SST	LEFT HAND
	2066625H	20666304H	COPPER/BRASS	RIGHT HAND
	2066625H	20666304H	COPPER/BRASS	LEFT HAND
10"	consult Factory	Consult Factory	316 SST	RIGHT HAND
	consult Factory	Consult Factory	316 SST	LEFT HAND
	consult Factory	20666305G	COPPER/BRASS	RIGHT HAND
	consult Factory	20666305G	COPPER/BRASS	LEFT HAND
12"	20666211K	Consult Factory	316 SST	RIGHT HAND
	20666211K	Consult Factory	316 SST	LEFT HAND
	consult Factory	Consult Factory	COPPER/BRASS	RIGHT HAND
	consult Factory	Consult Factory	COPPER/BRASS	LEFT HAND
16"	Consult Factory			
24"	Consult Factory			

