

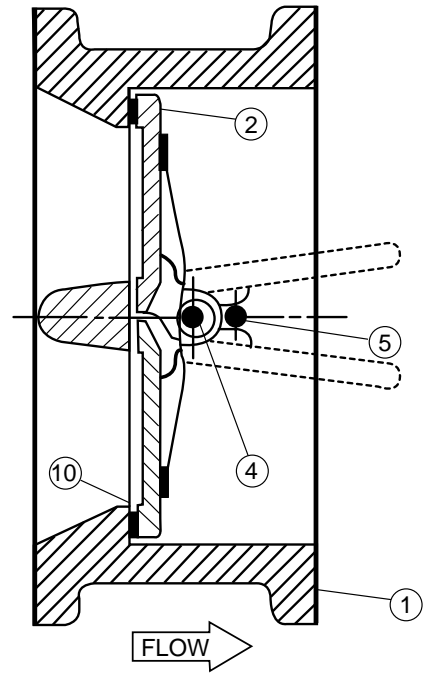

Two Door Check Valve Spare Parts Kits Prices

Explanation

Spare parts for Cla-Val Two Door Check Valves are readily available in a kit. Each kit includes all internal parts as shown below.

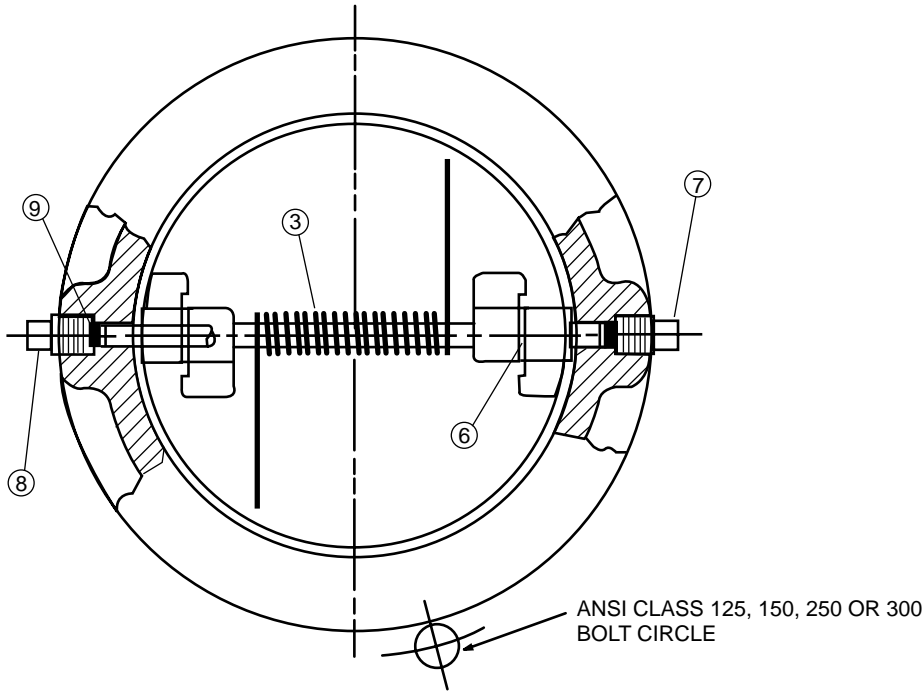

How to Order

Kit No. and Size	Price	Kit No. and Size	Price
SPK582-2"	\$ 88	SPK582-14"	Consult Factory
SPK582-2 1/2"	88	SPK582-16"	"
SPK582-3"	108	SPK582-18"	"
SPK582-4"	143	SPK582-20"	"
SPK582-5"	231	SPK582-24"	"
SPK582-6"	231	SPK582-30"	"
SPK582-8"	351	SPK582-36"	"
SPK582-10"	486	SPK582-42"	"
SPK582-12"	706	SPK582-48"	"
Above Include Bronze Doors			
SPKi-8810.2	561	Includes Ductile Iron Electroless Nickel Plated Doors	
SPK582-10.2			
SPKi-8812.2	803		
SPK582-12.2			

Check Valve Spare Parts Kit

Part	Description	Material
1	Body	Cast Iron (not included)
2	Doors	Bronze
3	Spring	Stainless Steel
	(qty 2 springs on 18" and larger)	
4	Hinge Pin	Stainless Steel
4B	Shaft Collar	Stainless Steel
	(Item 4B on 36" and larger sizes only)	
5	Stop Pin	Stainless Steel
6	Bearing (qty 4)	Stainless Steel
7	Hinge Pin Ret.	Steel (not included)
8	Stop Pin Ret.	Steel (not included)
9	Stab. Sphere	Buna-N®



Series 582A

Air Service Plain Ends 14" thru 30" Two-Door Wafer Check Valve



Sizes 14' & 16" only

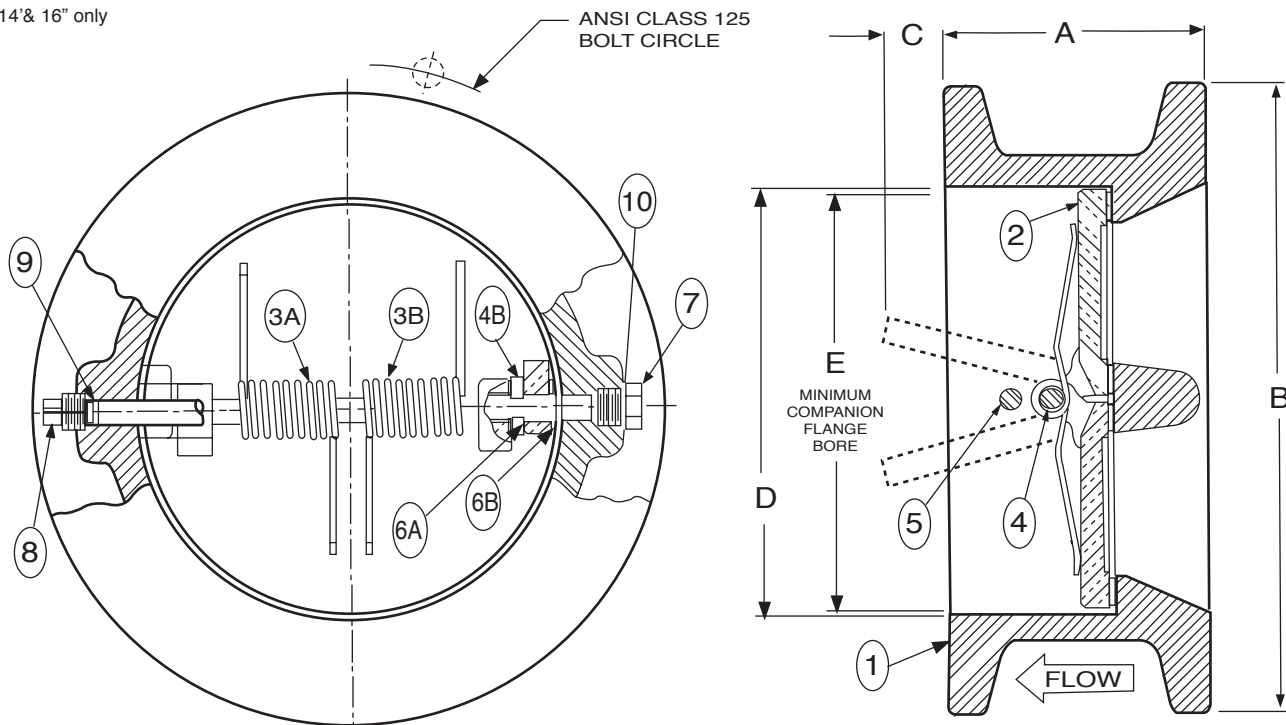

Part No.	Name	Material
1	Body	Cast Iron ASTM A536 with Buna-N® Molded in Seat
2	Doors	Alm. Bronze ASTM B95200
3	Torsion Springs	(Low Torque)
3A	(14"-16")	Stainless Steel T316 ASTM A316
3B	(18"-30")	Stainless Steel T17-7 PH ASTM A313
4	Door Hinge Pin	Stainless Steel T316 ASTM A276

Part No.	Name	Material
5	Door Stop Pin	Stainless Steel T316 ASTM A276
6	Door Thrust Bearing	Stainless Steel T316 ASTM A 240
7	Hinge Pin Retainer	Steel
8	Stop Pin Retainer	Steel
9	Stabilization Sphere	Buna-N®
10	Spacer	High Density Polyethylene

Note: 18' and larger utilizes two torsion springs

Dimensions (In Inches)

ANSI CLASS 125						
Size (inches)	Model	A	B	C	D	E
14	582A.14	7 1/4	17 3/4	3 1/8	14 3/8	12 1/2
16	582A.16	7 1/2	20 1/4	4 1/2	16 3/8	15
18	582A.18	8	21 5/8	5 3/8	18 3/8	17
20	582A.20	8 3/8	23 7/8	6 3/8	20 1/4	19
24	582A.24	8 3/4	28 1/4	8 1/2	24 1/4	23
30	582A.30	12	34 3/4	9 1/2	30	28 1/2

Pressure - Temperature Rating

Temp °F.	Maximum Non-Shock Pressure PSI (Ductile Iron Body)
150°F	150
200°F	115
250°F	85
Hydrostatic Test Pressure	225

Cla-Val Check Valves can only be used for Horizontal flow or vertical flow-up applications.

Caution: Horizontal flow applications, valve must be installed with the disc hinge in the vertical position.

All sizes supplied with lifting eyebolt.





Series 582G

Groove Ends 2" thru 12"

Two-Door Wafer Check Valve

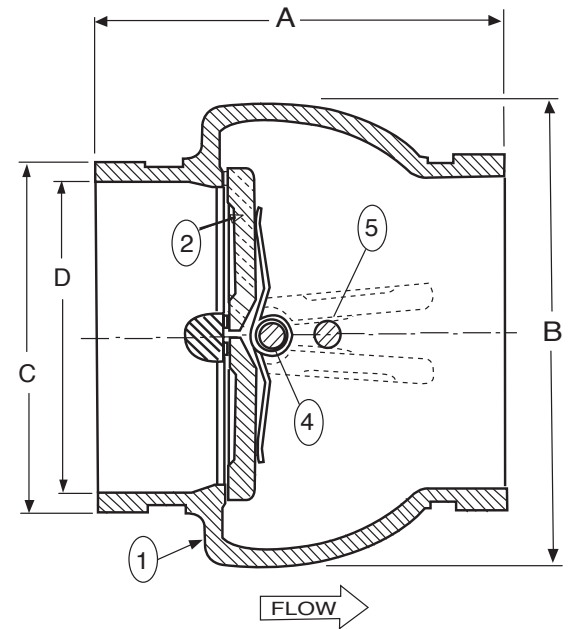
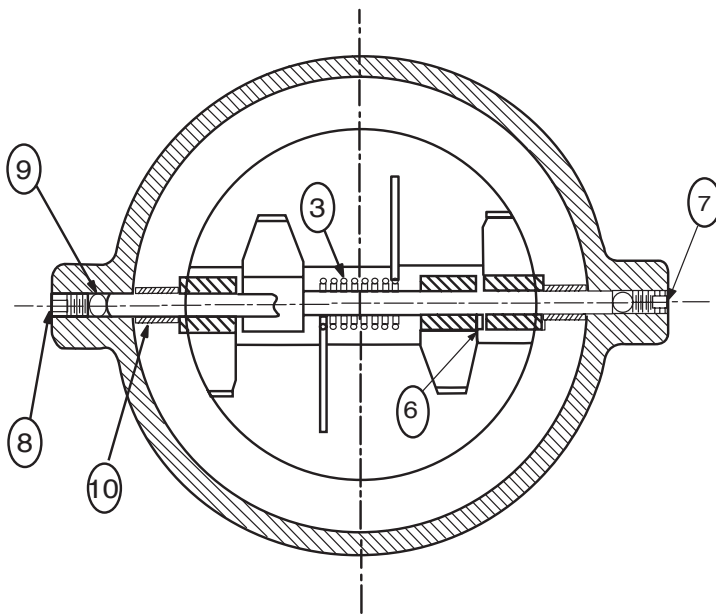

Part No.	Name	Material
1	Body	Ductile Iron ASTM A536 with Buna-N [®] Molded in Seat
2	Doors	Bronze ASTM B584, Alloy C83600
3	Torsion Spring	Stainless Steel B16 ASTM A316
4	Door Hinge Pin	Stainless Steel B16 ASTM A316
5	Door Stop Pin	Stainless Steel B16 ASTM A316

Part No.	Name	Material
6	Door Thrust Bearing	Stainless Steel T316 ASTM A240
7	Hinge Pin Retainer	Steel
8	Stop Pin Retainer	Steel
9	Stabilization Sphere	Buna-N [®]
10	Spacer	High Density Polyethylene

Dimensions (In Inches)

ANSI CLASS 125						
Size (Inches)	Model	A	B	C	D	E
2	582G.2	2 1/8	5 1/8	0	2 7/8	0
2 1/2	582G.25	2 3/8	6	1/8	3 1/2	1 5/16
3	582G.3	2 5/8	5 5/8	3/16	3 7/8	1 11/16
4	582G.4	2 5/8	7 3/4	5/8	4 3/4	3 1/16
5	582G.5	3 1/4	7 9/16	13/16	5 1/2	3 5/8
6	582G.6	3 3/4	8 5/8	13/16	6 1/4	4 1/4
8	582G.8	5	12 1/4	1	8	5 1/2
10	582G.10	5 1/2	14 3/4	2 1/16	10 1/4	8 1/2
12	582G.12	7 1/8	17 3/8	1 15/16	12	9 1/4

Pressure - Temperature Rating

Temp °F.	Maximum Non-Shock Pressure PSI (Ductile Iron Body)
150°F	250
200°F	235
250°F	220
Hydrostatic Test Pressure	500

Cla-Val Check Valves can only be used for Horizontal flow or vertical flow-up applications.

Caution: Horizontal flow applications, valve must be installed with the disc hinge in the vertical position.

Sizes 10" & 12" supplied with lifting eyebolt.



Series 582L

Lug Ends 36" thru 60"

Two-Door Wafer Check Valve

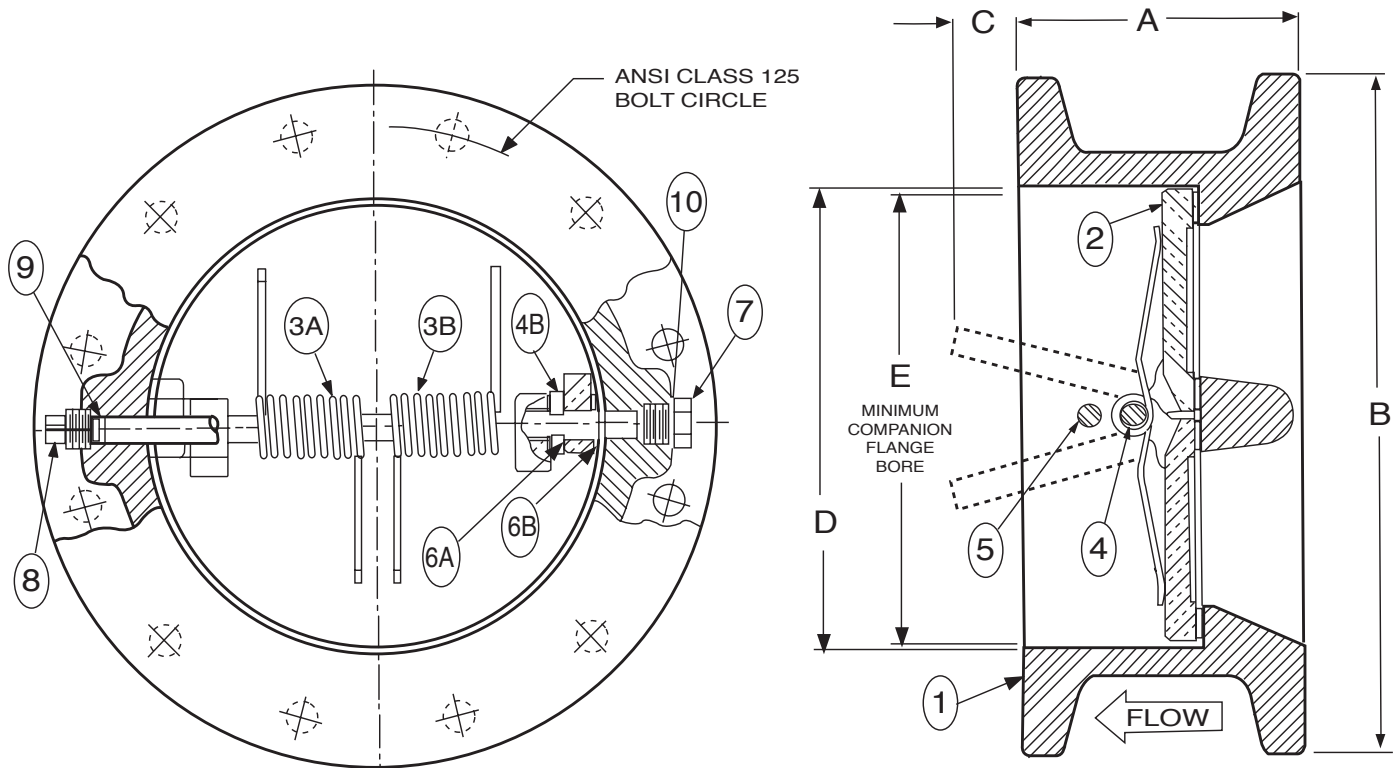

Part No.	Name	Material
1	Body	Cast Iron ASTM A126B with Buna-N® Molded in Seat
2	Doors	Aluminum Bronze ASTM B148-95200, Alloy C83600
3A	Torsion Springs (RH)	Stainless Steel T17-7 PH ASTM A313
3B	Torsion Springs (LH)	Stainless Steel T17-7 PH ASTM A313
4A	Hinge Pin	Stainless Steel T316 ASTM 240
4B	Shaft Collar	Stainless Steel T316 ASTM 240
5	Stop Pin	Stainless Steel T316 ASTM 240
6A	Inner Thrust Bearing	Stainless Steel T316 ASTM 240
6B	Outer Thrust Bearing	Stainless Steel T316 ASTM 240
7	Hinge Pin Retainer	Steel
8	Stop Pin Retainer	Steel
9	Stabilization Sphere	Buna-N®
10	O-Ring	Buna-N®

Pressure - Temperature Rating

Temp °F.	Maximum Non-Shock Pressure PSI (Ductile Iron Body)
150°F	150
200°F	135
250°F	125
Hydrostatic Test Pressure	225

Cla-Val Two Door Check Valves can only be used for Horizontal flow or vertical flow-up applications.

Caution: Horizontal flow applications, valve must be installed with the disc hinge in the vertical position.

All sizes supplied with lifting eyebolt.

For Air Service Applications See Drawing Series 582A (14" thru 30")

For Air Service Applications See Drawing Series 582WA (2" thru 12")

Dimensions (In Inches)

ANSI CLASS 125											
Size (inches)	Model	A	B	C	D	E	Threaded Lugs				
							No	B.C.	Thrds	Depth	
36	582L.36	14 1/2	41 1/4	12	36	34 1/2	32	42 3/4	1 1/2-6	2 1/4	
42	582L.42	17	48	13 3/4	42	40 1/2	36	49 1/2	1 1/2-6	2 1/2	
48	582L.48	20 5/8	54 1/2	17	48	46 1/2	44	56	1 1/2-6	2 1/2	
54	582L.54	21 1/4	60 1/2	18 1/4	54	49 1/4	44	62 3/4	1 3/4-5	2 1/2	
60	582L.60	26	73	18 1/4	60	53 1/4	52	69 1/4	1 3/4-5	2 1/2	



Series 582W

Wing Ends 2" thru 12"

Two-Door Wafer Check Valve

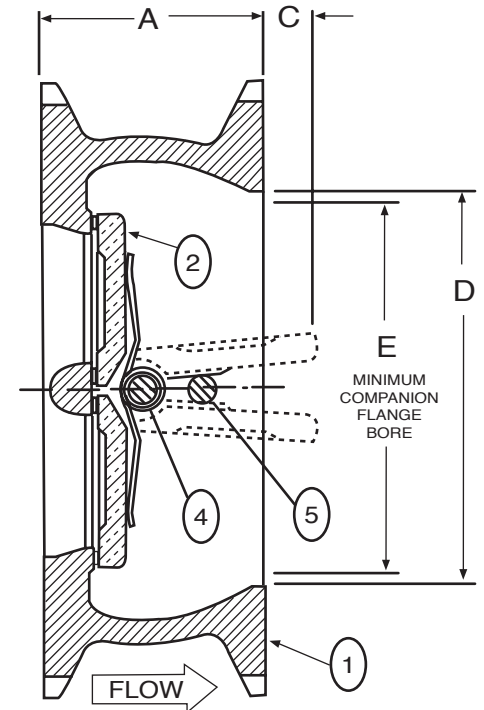
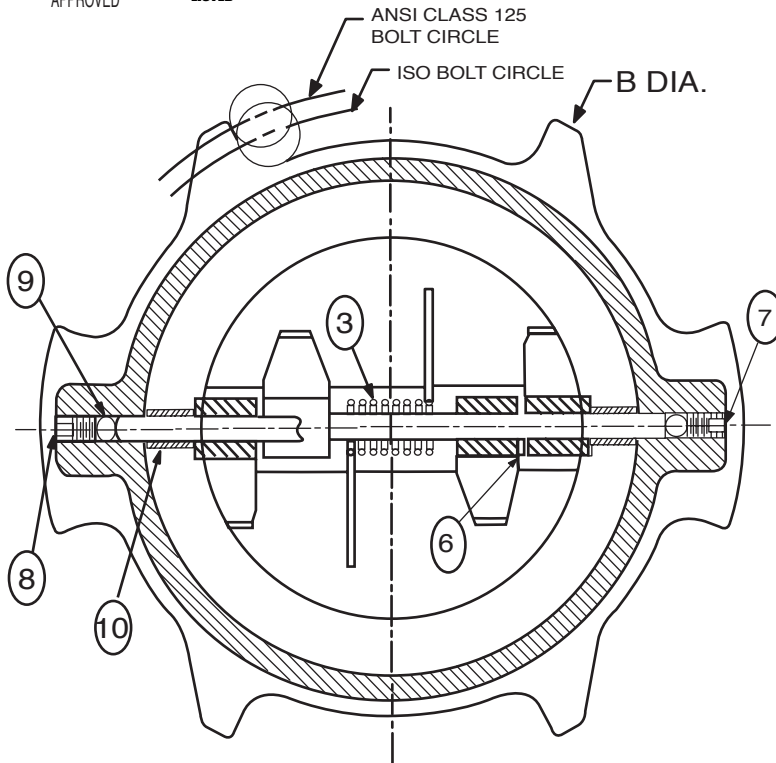

Part No.	Name	Material
1	Body	Ductile Iron ASTM A536 with Buna-N® Molded in Seat
2	Doors	Bronze ASTM B584, Alloy C83600
3	Torsion Spring	Stainless Steel T316 ASTM A316
4	Door Hinge Pin	Stainless Steel T316 ASTM A276
5	Door Stop Pin	Stainless Steel T316 ASTM A276

Part No.	Name	Material
6	Door Thrust Bearing	Stainless Steel T316 ASTM A240
7	Hinge Pin Retainer	Steel
8	Stop Pin Retainer	Steel
9	Stabilization Sphere	Buna-N®
10	Spacer	High Density Polyethylene

Dimensions (In Inches)

ANSI CLASS 125 - ISO PN10 / PN16						
Size (Inches)	Model	A	B	C	D	E
2	582W.2	2 1/8	5 1/8	0	2 7/8	0
2 1/2	582W.25	2 3/8	6	1/8	3 1/2	1 5/16
3	582W.3	2 5/8	5 5/8	3/16	3 7/8	1 11/16
4	582W.4	2 5/8	7 3/4	5/8	4 3/4	3 1/16
5	582W.5	3 1/4	7 9/16	13/16	5 1/2	3 5/8
6	582W.6	3 3/4	8 5/8	13/16	6 1/4	4 1/4
8	582W.8	5	12 1/4	1	8	5 1/2
10	582W.10	5 1/2	14 3/4	2 1/16	10 1/4	8 1/2
12	582W.12	7 1/8	17 3/8	1 15/16	12	9 1/4

Pressure - Temperature Rating

Temp °F.	Maximum Non-Shock Pressure PSI (Ductile Iron Body)
150°F	250
200°F	235
250°F	220
Hydrostatic Test Pressure	500

Cla-Val Check Valves can only be used for Horizontal flow or vertical flow-up applications.

Caution: Horizontal flow applications, valve must be installed with the disc hinge in the vertical position.

For Air Service Applications See Drawing Series 582A (2" thru 12") Sizes 10" & 12" supplied with lifting eyebolt.



Series 582WA

Air Service Wing Ends 2" thru 12"

Two-Door Wafer Check Valve

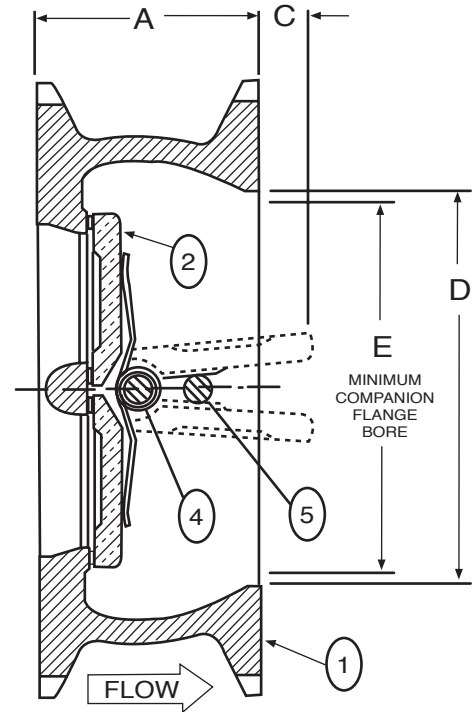
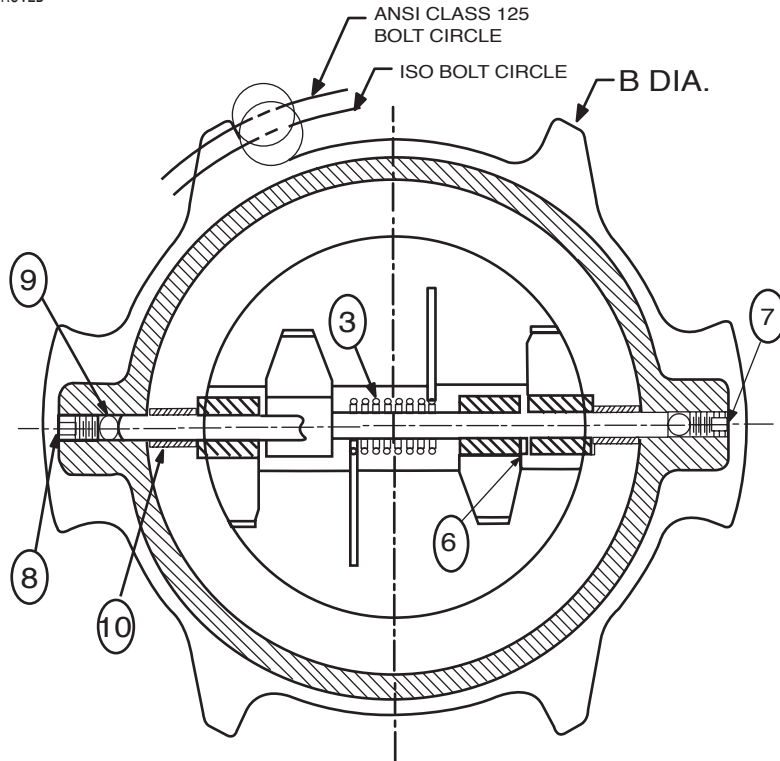

Part No.	Name	Material
1	Body	Ductile Iron ASTM A536
2	Doors	Bronze ASTM B584, Alloy C83600
3	Torsion Spring	Stainless Steel B16 ASTM A316
4	Door Hinge Pin	Stainless Steel B16 ASTM A276
5	Door Stop Pin	Stainless Steel B16 ASTM A276

Part No.	Name	Material
6	Door Thrust Bearing	Stainless Steel T316 ASTM A240
7	Hinge Pin Retainer	Steel
8	Stop Pin Retainer	Steel
9	Stabilization Sphere	Buna-N®
10	Spacer	High Density Polyethylene

Dimensions (In Inches)

ANSI CLASS 125 - ISO PN10 / PN16						
Size (Inches)	Model	A	B	C	D	E
2	582WA.2	2 1/8	5 1/8	0	2 7/8	0
2 1/2	582WA.25	2 3/8	6	1/8	3 1/2	1 5/16
3	582WA.3	2 5/8	5 5/8	3/16	3 7/8	1 11/16
4	582WA.4	2 5/8	7 3/4	5/8	4 3/4	3 1/16
5	582WA.5	3 1/4	7 9/16	13/16	5 1/2	3 5/8
6	582WA.6	3 3/4	8 5/8	13/16	6 1/4	4 1/4
8	582WA.8	5	12 1/4	1	8	5 1/2
10	582WA.10	5 1/2	14 3/4	2 1/16	10 1/4	8 1/2
12	582WA.12	7 1/8	17 3/8	1 15/16	12	9 1/4

Pressure - Temperature Rating

Temp °F.	Maximum Non-Shock Pressure PSI (Ductile Iron Body)
150°F	250
200°F	235
250°F	220
Hydrostatic Test Pressure	500

Cla-Val Check Valves can only be used for Horizontal flow or vertical flow-up applications.

Caution: Horizontal flow applications, valve must be installed with the disc hinge in the vertical position.

Sizes 10" & 12" supplied with lifting eyebolt.





Series 582

Plain Ends 14" thru 30"

Two-Door Wafer Check Valve



Sizes 14" & 16" only

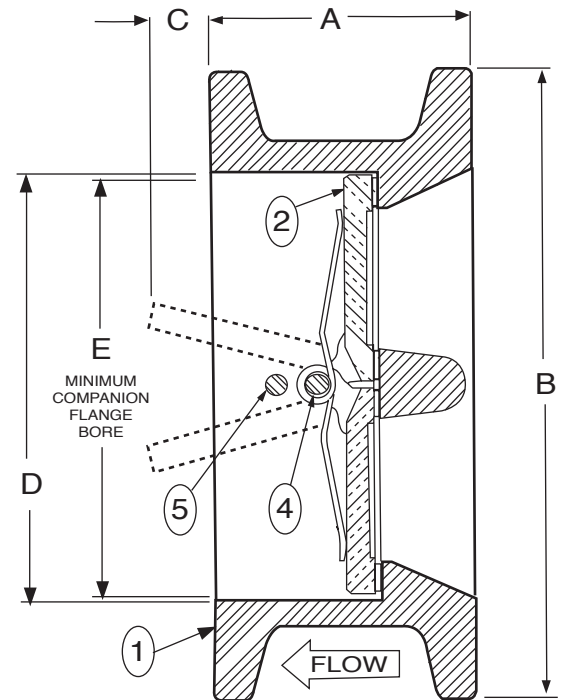
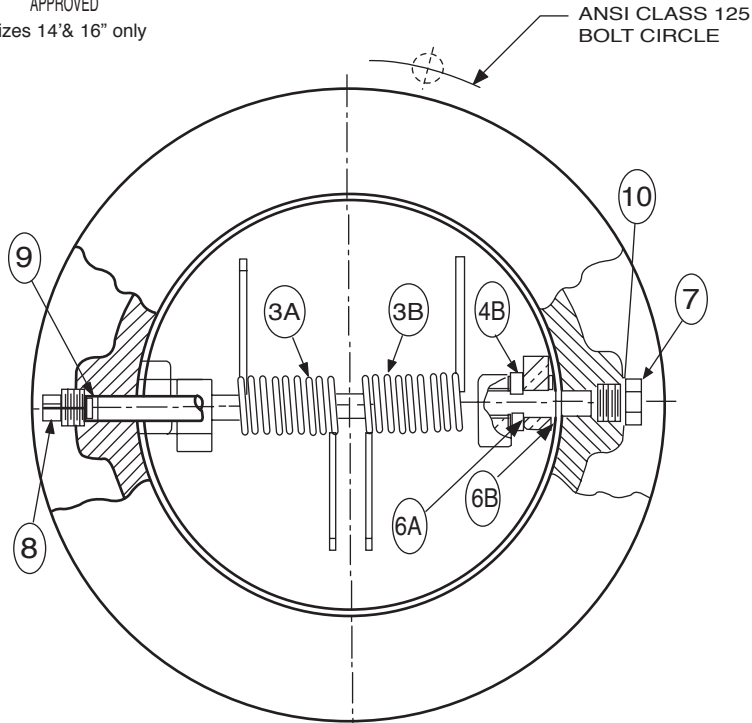

Part No.	Name	Material
1	Body	Ductile Iron ASTM A536
2	Doors	Bronze ASTM B584, Alloy C83600
3	Torsion Springs	
3A	(14"-16")	Stainless Steel T316 ASTM A313
3B	(18"-30")	Stainless Steel T17-7 PH ASTM A313

Part No.	Name	Material
4	Door Hinge Pin	Stainless Steel T316 ASTM A276
5	Door Stop Pin	Stainless Steel T316 ASTM A276
6	Door Thrust Bearing	Stainless Steel T316 ASTM A240
7	Hinge Pin Retainer	Steel
8	Stop Pin Retainer	Steel
9	Stabilization Sphere	Buna-N®
10	Spacer	High Density Polyethylene

Dimensions (In Inches)

ANSI CLASS 125 - ISO PN10 / PN16						
Size	Model	A	B	C	D	E
14	582.14	7 1/4	17 3/4	3 1/8	14 3/8	12 1/2
16	582.16	7 1/2	20 1/4	4 1/2	16 3/8	15
18	582.18	8	21 5/8	5 3/8	18 3/8	17
20	582.20	8 3/8	23 7/8	6 3/8	20 1/4	19
24	582.24	8 3/4	28 1/4	8 1/2	24 1/4	23
30	582.30	12	34 3/4	9 1/2	30	28 1/2

Sizes 18" & Larger utilize (2) torsion springs

Cla-Val Check Valves can only be used for Horizontal flow or vertical flow-up applications.

Caution: Horizontal flow applications, valve must be installed with the disc hinge in the vertical position.

All sizes supplied with lifting eyebolt.

For Larger Valves see Series 582 (36"-54") plain Ends -Wafer Check Valve.

For Air Service Applications See Drawing Series 582A (14" thru 30")

Pressure - Temperature Rating

Temp °F.	Maximum Non-Shock Pressure PSI (Ductile Iron Body)
150°F	250
200°F	235
250°F	220
Hydrostatic Test Pressure	500



Series 582

Plain Ends 36" thru 60"

Two-Door Wafer Check Valve

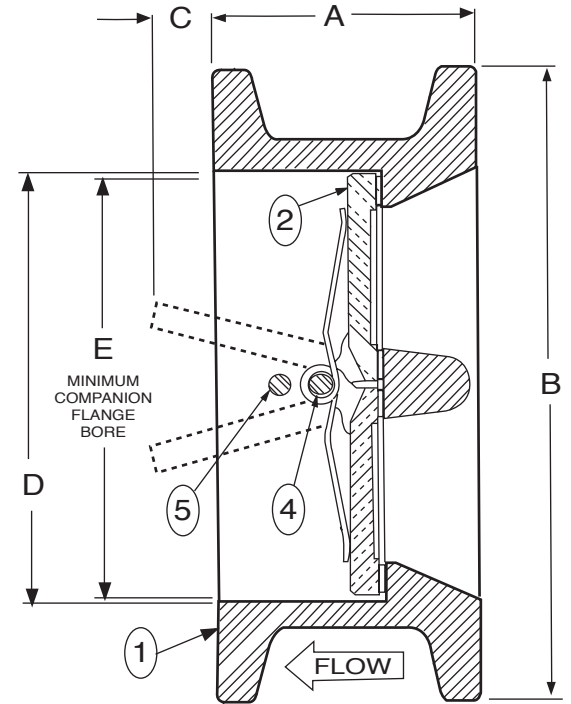
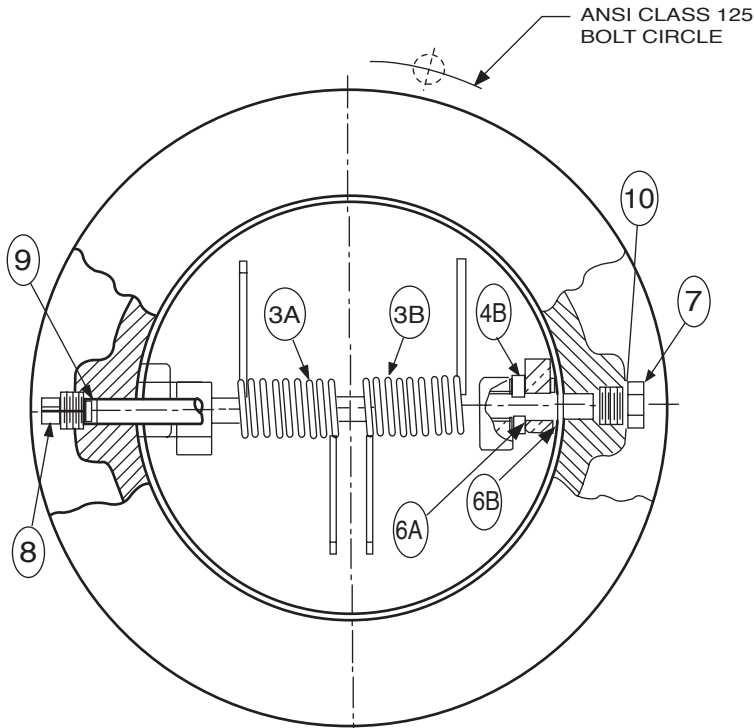

Part No.	Name	Material
1	Body	Cast Iron ASTM A126B with Buna-N® Molded in Seat
2	Doors	Aluminum Bronze ASTM B148-95200, Alloy C83600
3A	Torsion Springs (RH)	Stainless Steel T17-7 PH ASTM A313
3B	Torsion Springs (LH)	Stainless Steel T17-7 PH ASTM A313
4A	Hinge Pin	Stainless Steel T316 ASTM 240
4B	Shaft Collar	Stainless Steel T316 ASTM 240
5	Stop Pin	Stainless Steel T316 ASTM 240
6A	Inner Thrust Bearing	Stainless Steel T316 ASTM 240
6B	Outer Thrust Bearing	Stainless Steel T316 ASTM 240
7	Hinge Pin Retainer	Steel
8	Stop Pin Retainer	Steel
9	Stabilization Sphere	Buna-N®
10	O-Ring	Buna-N®

Pressure - Temperature Rating

Temp °F.	Maximum Non-Shock Pressure PSI (Ductile Iron Body)
150°F	150
200°F	135
250°F	125
Hydrostatic Test Pressure	225

Dimensions (In Inches)

ANSI CLASS 125						
Size (inches)	Model	A	B	C	D	E
36	582.36	14 1/2	41 1/4	12	36	34 1/2
42	582.42	17	48	13 3/4	42	40 1/2
48	582.48	20 5/8	54 1/2	17	48	46 1/2
54	582.54	21 1/4	60 1/2	18 1/4	54	49 1/4
60	582.60	26	73	18 1/4	60	53 1/4

Cla-Val Check Valves can only be used for Horizontal flow or vertical flow-up applications.

Caution: Horizontal flow applications, valve must be installed with the disc hinge in the vertical position.

All sizes supplied with lifting eyebolt.

For Air Service Applications See Drawing Series 582A (14" thru 30")
For Air Service Applications See Drawing Series 582WA (2" thru 12")