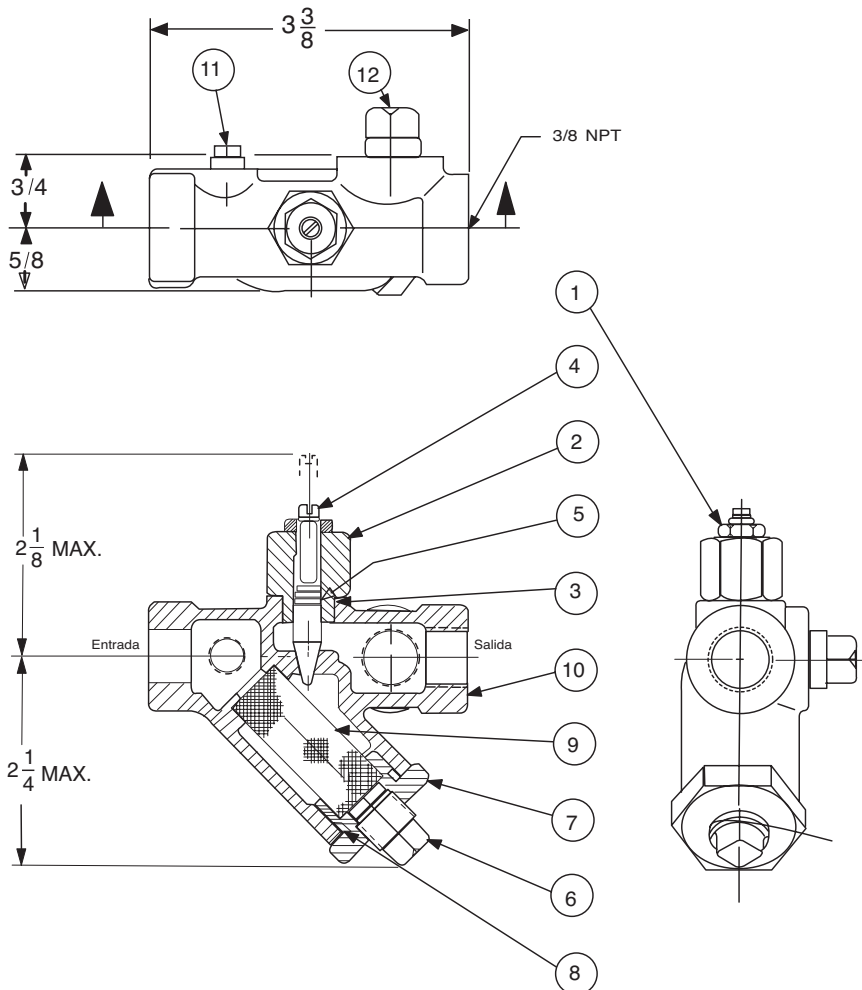

X42N-2**Ensamble de Filtro y Valvula de Aguja**

**Quando ordene partes,
por favor especifique:**

- Toda la informacion de placa
- Numero de articulo
- Descripcion

Medida	Numero de Stock
3/8" x 3/8"	68372C

ARTICULO	DESCRIPCION	MATERIAL	No. DE PARTE
1	Tuerca de seguridad - Hex	Bronce Sil	6779806G
2	Capote	Acero Inoxidable	67910A
3	Empaque redondo - Capote	Hule Sintetico	00713J
4	Vastago	Acero Inoxidable	67907G
5	Empaque redondo - Vastago	Hule Sintetico	00708J
6	Tapon - NPT 1/4	Bronce	6784702A
7	Tapon del filtro	303	67911J
8	Empaque redondo - Tapon	NBR	00751J
9	Malla	Monel	68373A
10	Cuerpo	Laton Rd	67905A
11	Tapon - NPT 1/8	Laton	6784701C
12	Tapon - NPT 3/8	Laton	67660-03F