



— MODEL — **X102**

Flow Limiting Assembly & Pilot System Components



X102A



X102B



X102D

- Automatic Operation
- Corrosion Resistant
- No Lubrication
- Easy Adjustment
- Easy Maintenance

The Cla-Val Model X102 Flow Limiting Assemblies regulate flow through Cla-Val Automatic Valves from full flow to shut-off. These adjustable assemblies control flow by limiting the amount of the valve opening.

The X102A and X102D maintain a pressure seal during adjustment by means of an internal "O" Ring.

The X102B is pressure sealed by means of an external resilient washer, compressed when the Jam Nut is tightened, after adjustment.

X102A

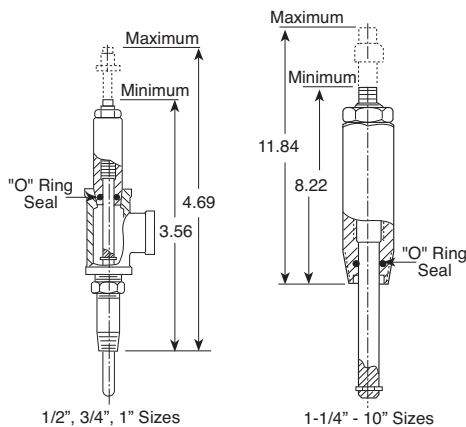

X102B

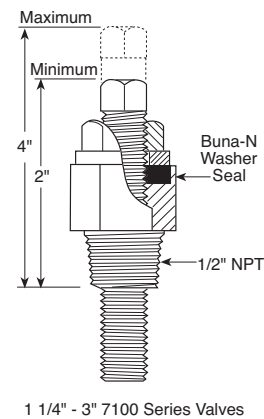

X102D

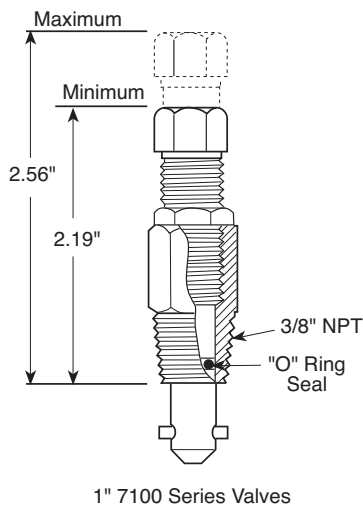

Specifications

Pressure Ratings:

Valves 1/2" through 3"	150 psi maximum
Valves 4" and 6"	100 psi maximum
Valves 8"	30 psi maximum
Valves 10"	20 psi maximum

Materials:

Body (all models)	Brass
Stem X102A	303 Stainless Steel
X102B	Brass
X102D	Brass

When Ordering, Please Specify

When ordering please specify the following information:

1. Flow Limiting Assembly Catalog Number
2. Valve Catalog Number
3. Valve Size