

—MODEL— **7100**

Remote Control Valve

DESCRIPTION

The Cla-Val 7100 Valve is a hydraulically operated, diaphragm actuated, globe pattern valve. This valve consists of three major components, the Body, with Fusion Bonded Epoxy Coating Standard, Diaphragm Assembly and Cover. The Diaphragm Assembly is the only moving part.

The Body contains a renewable seat insert.

The Diaphragm Assembly uses a diaphragm of nylon fabric bonded with synthetic rubber. A synthetic rubber disc forms a seal with the valve seat when pressure is applied above the diaphragm. The Diaphragm Assembly forms a sealed chamber in the upper portion of the valve, separating operating pressure from line pressure.

OPERATION

When equipped with a three-way control valve the Cla-Val 7100 Valve either opens wide or closes tight.

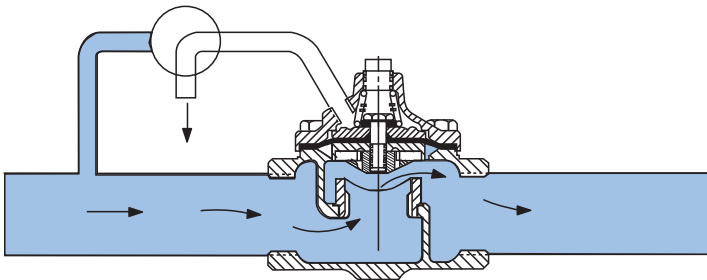

VALVE OPEN

When pressure in diaphragm chamber is relieved to a zone of lower pressure (usually atmosphere) the line pressure at the valve seat opens the valve.

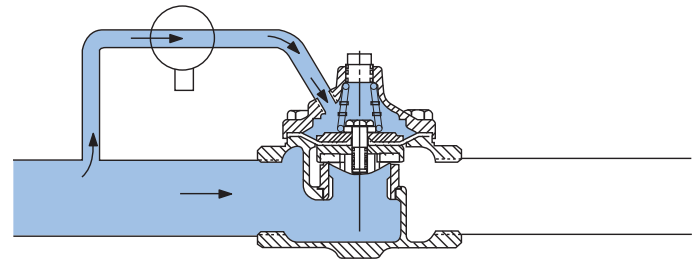

VALVE CLOSED

When pressure from the valve inlet (or an equivalent independent operating pressure) is applied to the diaphragm chamber the valve closes drip-tight.

INSTALLATION

1. Before valve is installed, pipe lines should be flushed of all chips, scale and foreign matter.
2. Place valve in the line with flow through the valve in the direction indicated on inlet plate or by flow arrows.
3. Allow sufficient room around valve to make adjustments, and for disassembly.
4. Cla-Val 7100 Valves operate in any position.
5. If a pilot control system is installed with the 7100 Valve, use care to prevent damage. If necessary to remove fittings or tubing, be sure they are kept clean and replaced exactly as they were.
6. After the valve is installed and the system is first pressurized, vent air from the cover chamber and tubing by loosening fittings at all high points.

MAINTENANCE

Cla-Val 7100 Valves require no lubrication or packing and a minimum of maintenance.

Disassembly

The inspection or maintenance of the 7100 Valve can be accomplished without removal from the line. After pressure has been shut off and the pressure released from the valve and cover chamber, unscrew cover bolts and remove Cover, Spring and Diaphragm Assembly. Remove seat only if damage is evident. Check Disc for excessive wear or embedded particles.

Reassembly

To reassemble reverse the order of disassembly.

Parts List

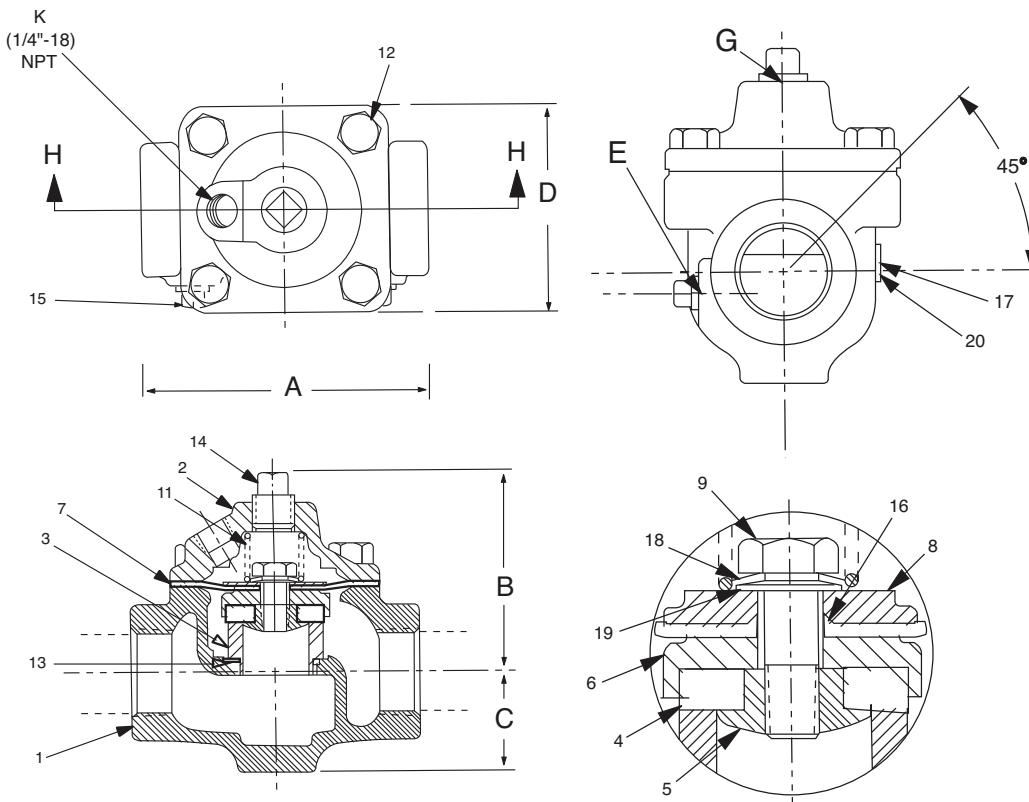

Item No.	Description	Qty.
1.	Body	1
2.	Cover	1
3.	Seat	1
4.	Disc	1
5.	Guide, Disc	1
6.	Retainer Disc	1
7.	Diaphragm	1
8.	Washer, Diaphragm	1
9.	Bolt, Stem	1
10.	Nut, Hex	1
11.	Spring	1
12.	Bolt Hex Hd.	4
13.	O-Ring	1
14.	Plug, Pipe	1
15.	Plug, Pipe	1
16.	O-Ring	1
17.	Screw Drive	2
18.	Washer, Bellville	1
19.	Washers	1
20.	Nameplate	1

SERVICE SUGGESTIONS

SYMPTOM	PROBABLE CAUSE	PROCEDURE
Fails to Close	Insufficient Pressure to Cover Chamber	Check Pilot Control System Pressure. In order for valve to close, pressure to valve cover chamber must be equal to, or greater than, pressure at valve inlet.
	Damaged Diaphragm	The following method will determine if there is a damaged diaphragm without removing the valve cover: Put pressure into the valve and disconnect control tube from valve cover chamber. If there is continuous flow through the tube connector fitting, the diaphragm is damaged, or the diaphragm assembly on the stem bolt is loose.
Closes but fails to hold drip tight	Mechanical Obstruction	Remove valve cover, and diaphragm-disc assembly. Check for foreign objects in valve seat or imbedded in valve disc.
	Worn disc or scarred seat	Check as above, and replace disc or seat if necessary.
Fails to Open	Insufficient line pressure	Minimum requirement with cover chamber vented to atmosphere, 7-10 psi (7100KH).
	Pilot Control System not draining to atmosphere	With line pressure in valve, disconnect control tube from valve cover chamber. Valve should open. Check for obstruction in control tube, pilot valve and pilot valve drain to atmosphere
Hammers while opening and continues to pulsate while flowing.	Low flow condition with fall of pipe at valve outlet creating negative pressure at valve outlet	At top of pipe fall, install air vent to break vacuum. A small spring loaded ball check may be installed in downstream body tapping of valve.