



—MODEL—

# 50-01/650-01

## Pressure Relief, Pressure Sustaining & Back Pressure Valve

### INTRODUCTION

The Cla-Val 50-01/650-01 is an automatic control valve designed to maintain constant upstream pressure to close limits. It is a hydraulically operated, pilot controlled, modulating type valve. It is used where pressure relief or pressure sustaining functions in a bypass system are required.

The valve is actuated by inlet line pressure, opening to maintain a steady line pressure and closing gradually to prevent surges. When inlet pressure is below the pressure setting CRL-60 pilot control, the main valve and pilot are closed drip tight. Pressure setting adjustment is made with single adjusting screw that has a protective cap to discourage tampering.

### INSTALLATION

1. Allow sufficient room around the valve assembly to make adjustments and for servicing.

2. It is recommended that gate or block valves be installed to facilitate isolating valve for preventative maintenance. When used as a surge control or pressure relief valve where valve outlet discharge is to atmosphere, then a gate or block valve is needed at valve inlet. When used as a back pressure sustaining control valve where valve outlet is connected to pressurized downstream system, then gate or block valves are needed at valve inlet and outlet.

**NOTE: BEFORE THE VALVE IS INSTALLED, PIPE LINES SHOULD BE FLUSHED OF ALL FOREIGN MATTER.**

3. Place valve in line with flow through valve in direction indicated on inlet plate or flow arrows. Check all fittings and hardware for proper makeup and verify that no apparent damage is evident.

4. Cla-Val Valves operate with maximum efficiency when mounted in horizontal piping with the cover UP; however, other positions are acceptable. Due to size and weight of cover and internal components on six inch and larger valves, installation with the cover up is advisable. This makes periodic inspection of internal parts readily accessible.

5. Caution must be taken in the installation of this valve to insure that galvanic and/or electrolytic action does not take place. The proper use of dielectric fittings and gaskets are required in all systems using dissimilar metals.

### OPERATION AND START-UP

1. Prior to pressurizing the valve assembly make sure the necessary gauges to measure pressure in the system, are installed as required by the system engineer. A Cla-Val X101 Valve Position Indicator may be installed in the center cover port to provide a visual indication of the valve stem position during startup adjustment.

**CAUTION:** During start-up and test a large volume of water may be discharged downstream. Check that the downstream venting is adequate to prevent damage to personnel and equipment. **All pilot adjustments should be made slowly in small increments.** If the main valve closes too rapidly it may cause surging in upstream piping.

2. If isolation valves (B) are installed in pilot system open these valves (see schematic).

3. Loosen jam nut on X42N-2 strainer valve assembly and turn adjusting stem clockwise until it seats. Then turn stem counterclockwise 1/4 to 1/2 turn and tighten jam nut for an initial setting.

4. Remove cap on the CRL-60 Pressure Relief Control, loosen jam nut and turn adjusting screw clockwise until spring is fully compressed. This puts the control in full closed mode and will cause the main valve to close when system is pressurized.

5. If a downstream block valve is installed, slowly open this valve.  
6. Partially open upstream block valve. The main valve should close.

7. Carefully loosen the plug at top of indicator assembly. If an indicator (X101) is installed, loosen the bleed valve at top of indicator. Bleed air from cover and tighten plug or bleed valve. Carefully loosen tubing fittings at highest points and bleed air from system. Retighten fittings.

8. Open fully the upstream block valve and turn the CRL-60 adjusting screw slowly counterclockwise until you begin to hear a flow through the control. The main valve should start to open. If the pressure is below the required relief setting, refer to the spring chart and turn the adjusting screw clockwise the number of turns required for the proper setting. Lock the jam nut and replace cover. An observation of the pressure relief setting should be made during usage. The controls can be readjusted as required.

### MAINTENANCE

1. Cla-Val Valves and Controls require no lubrication or packing and a minimum of maintenance. However, a periodic inspection schedule should be established to determine how the fluid is affecting the efficiency of the valve assembly. Minimum of once per year.

2. Repair and maintenance procedures of the Hytrol Main Valve and control components are included in a more detailed IOM manual. It can be downloaded from our web site ([www.cla-val.com](http://www.cla-val.com)) or obtained by contacting a Cla-Val Regional Sales Office.

**3. When ordering parts always refer to the catalog number and stock number on the valve nameplate.**

SYMPTOM	PROBABLE CAUSE	REMEDY
Main valve won't open	Inlet pressure below setting of pilot valve	Reset pilot valve. If change in setting is from tampering, seal cap with wire and lead seal
	Pilot valve stuck closed Mineral deposit or foreign material between disc retainer and power unit body	Disassemble control and clean
	Pilot valve diaphragm ruptured or diaphragm nut loose. Water coming out of the vent hole in cover	Disassemble and replace diaphragm Tighten nut
clean	Main valve stuck closed	Disassemble main valve,
	Mineral buildup on stem Stem damaged	parts and/or replace damaged part. Check downstream and cover CK2 isolation valves are open
Main valve won't close	Inlet pressure above setting of pilot valve	Reset pilot valve
	Clogged needle valve or strainer	Disassemble and clean
	Pilot valve stuck open. Mineral deposit or foreign material under disc retainer or under diaphragm assembly	Disassemble and clean
	Main valve stuck open. Mineral buildup on stem. Foreign material between seat and disc assembly	Disassemble and clean
Valve leaks Continuously	Main valve diaphragm worn	Disassemble and replace
	Pilot valve disc worn out	Disassemble and replace
	Main valve disc worn or small pin hole in main valve diaphragm	Disassemble and replace
	Set point too close to inlet pressure	Reset CRL-60 Pilot

# 50-01/650-01 SCHEMATIC

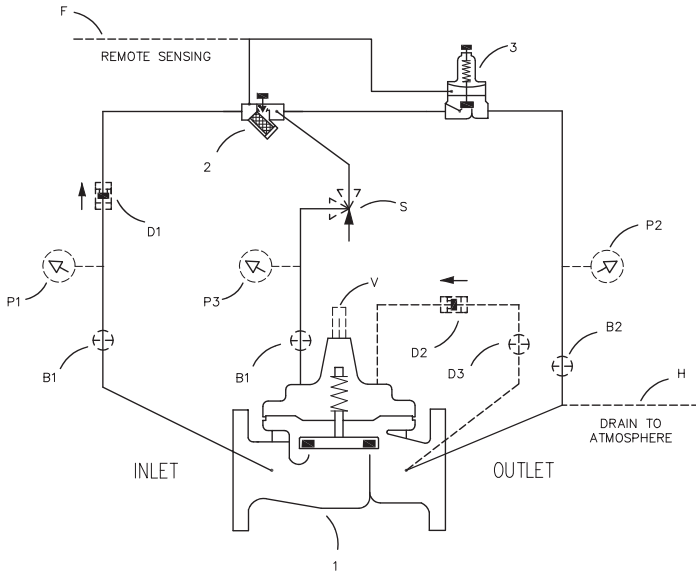

### BASIC COMPONENTS

- 1 100-01 Hytrol (Main Valve)
- 100-20 600 Series Hytrol (Main Valve)
- 2 X42N-2 Strainer Needle Valve
- 3 CRL-60 Pressure Relief Control

### OPTIONAL FEATURES

- B CK2 (Isolation Valves)
- D Check Valves with Isolation Valve
- F Remote Sensing
- H Drain to Atmosphere
- P X141 Pressure Gauge
- S CV Speed Control (Opening)
- V X101 Valve Position Indicator

## 1 HYTROL MAIN VALVE

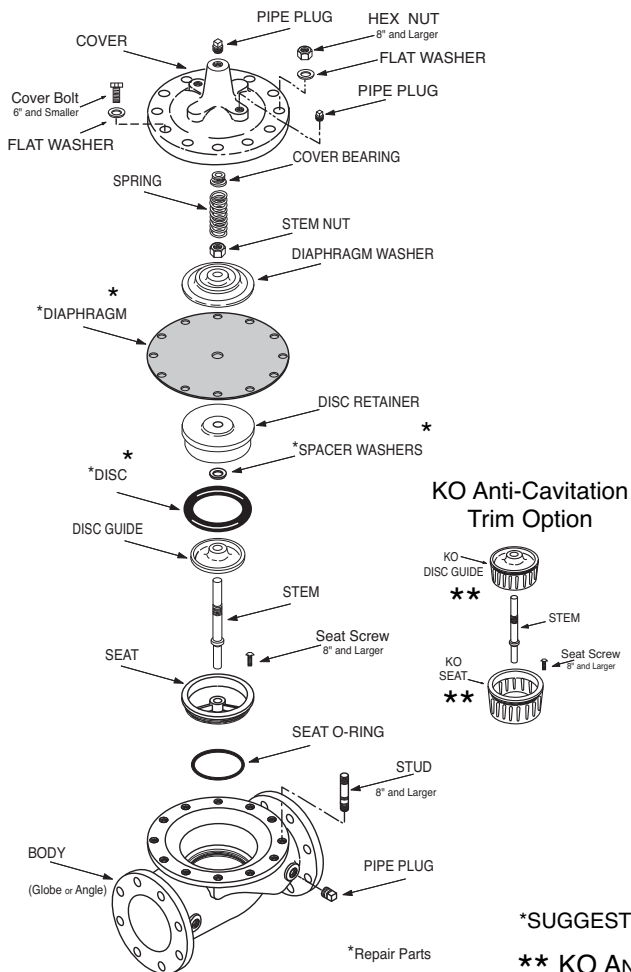

\*SUGGESTED REPAIR PARTS

\*\* KO ANTI-CAVITATION TRIM CAN BE ADDED TO ANY STANDARD HYTROL VALVE

## 3 CRL-60

X140-1  
Security Cap  
Option

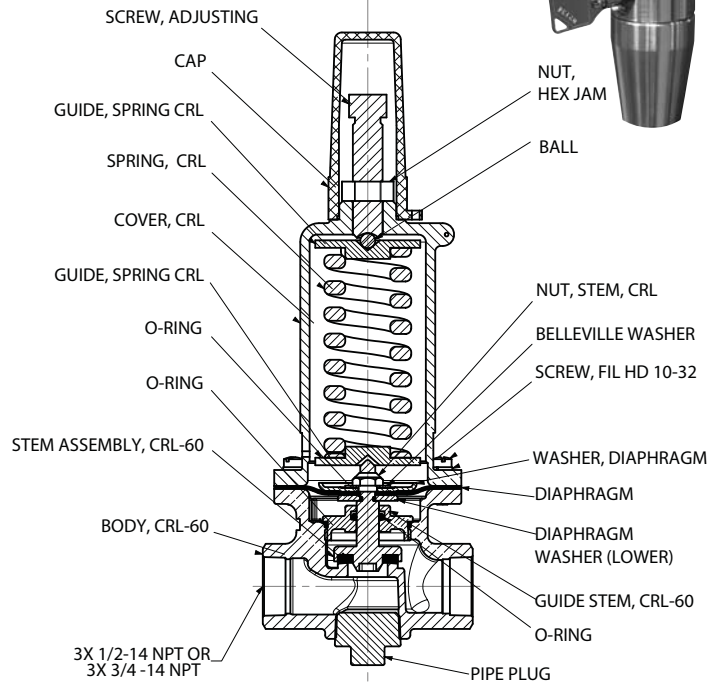

CRL-60 (100 - 300 psi) configuration shown

CRL-60 adjustment range (psi)	Spring Color	psi change per turn*
0 - 75	Red	8.5
20 - 105	Silver	12.0
20 - 200	Green	28
100 - 300	Yellow	18

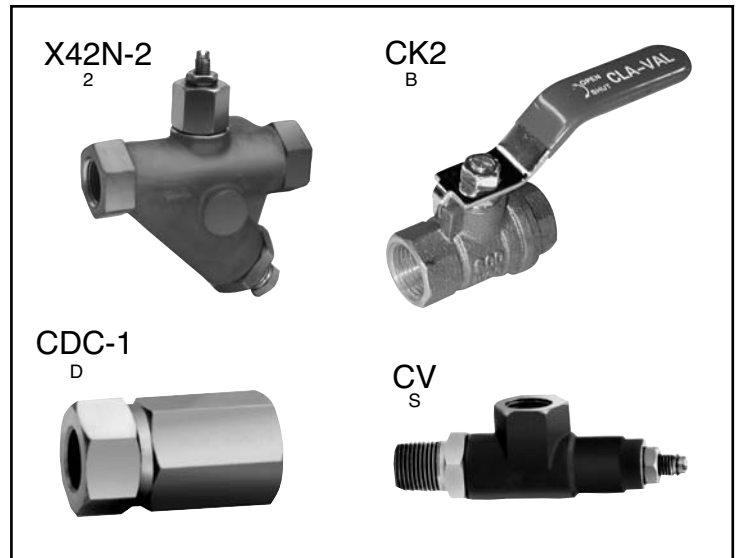

For a more detailed IOM Manual go to [www.cla-val.com](http://www.cla-val.com) or contact a Cla-Val Regional Sales Office.