CLA-VAL

AUTOMATIC CONTROL VALVES

60-19/660-19

Place this manual with personnel responsible
for maintenance of this valve



Installation

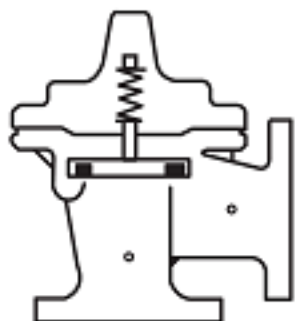

Operation

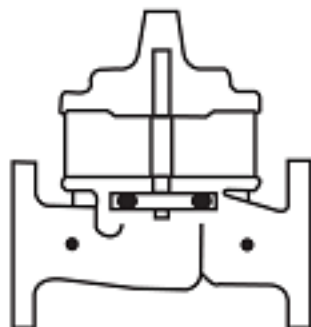

Maintenance





NEWPORT BEACH, CALIFORNIA

CATALOG NO. 60-19/660-19

DRAWING NO. 97829

REV. E

TYPE OF VALVE AND MAIN FEATURES

PUMP CONTROL VALVE WITH HIGH CAPACITY PILOT SYSTEM

DESIGN		
DRAW	RW	8-28-80
CHK'D	KD	9-9-80
APVD	CH	9-11-80

CAD REVISION RECORD - DO NOT REVISE MANUALLY
 C REMOVED CK2 COCK ITEM B1 ON OUTLET; ITEM B WAS B2 (ECO 14463)
 D ITEM NO. 2 CS3M WAS CS3 (ECO 14791)
 E DISCONNECTED N.O. PORT OF ITEM 3B FROM SUPPLY & ADDED ATMOSPHERIC DRAIN (ECO 14806)
 BY DATE
 A SEE REVISION FILE
 B COMBINED & INCLUDED (660-19), DWG 21311 (ECO 14352)
 LTR DESCRIPTION
 1-7-94
 TLC
 2-25-94
 CN
 7-05-94
 TLC
 7-13-94

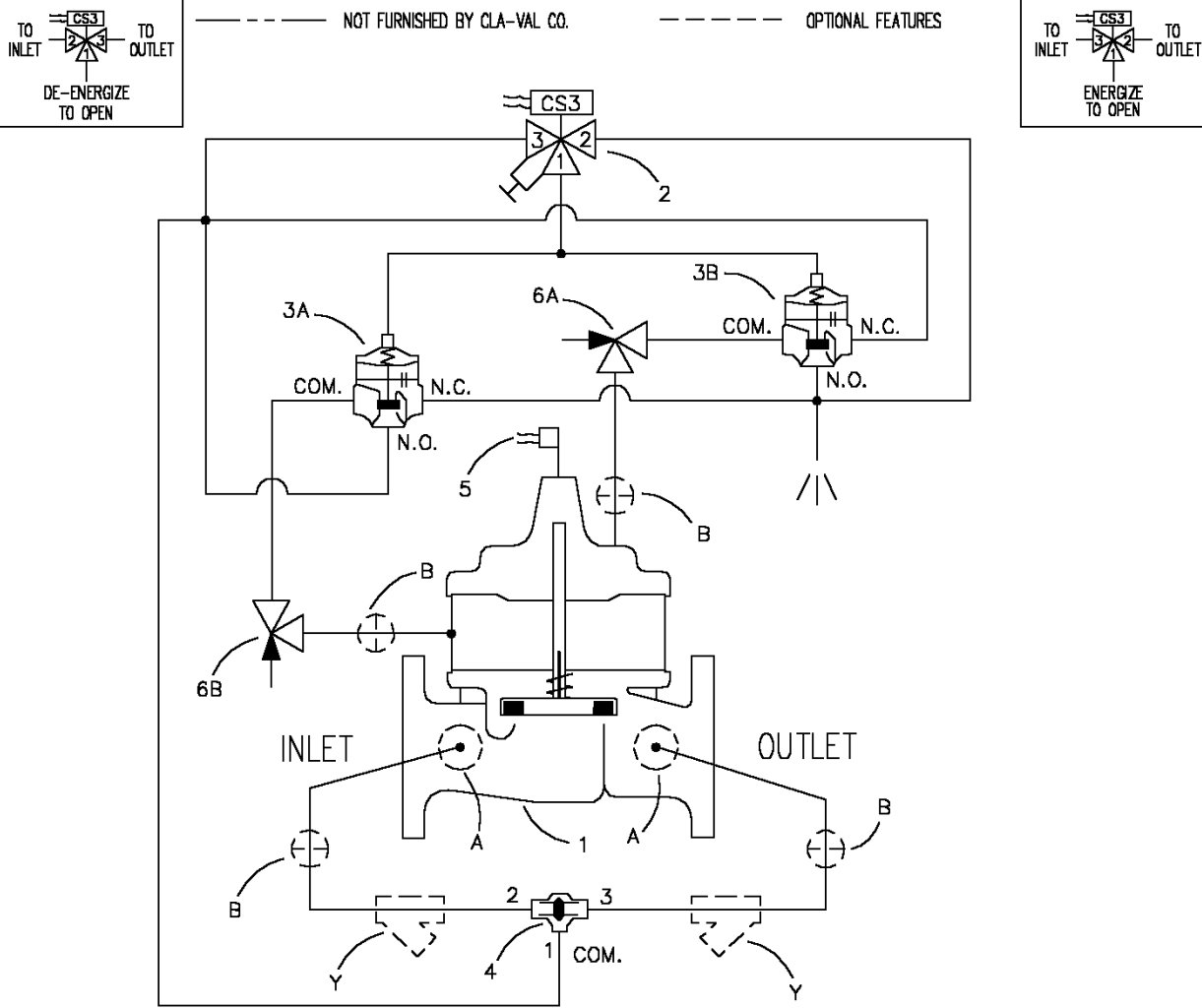

ITEM NO.	BASIC COMPONENTS	QTY
1	100-03 POWERCHECK (60-19) MAIN VALVE	1
	100-22 POWERCHECK (660-19) MAIN VALVE	
2	CS3M SOLENOID CONTROL	1
3	102C-3H 3-WAY VALVE	2
4	CVS-1 SHUTTLE VALVE	1
5	X105LCW SWITCH ASSEMBLY	1
6	CV FLOW CONTROL	2

OPTIONAL FEATURE SUFFIX	ADDED TO CATALOG NUMBER	QTY
A	X46A FLOW CLEAN STRAINER	2
B	CK2 COCK (ISOLATION VALVE)	4
Y	X43 "Y" STRAINER	2

THIS DRAWING IS THE PROPERTY OF CLA-VAL CO. AND SAME AND COPIES MADE THEREOF, IF ANY, SHALL BE RETURNED TO IT UPON DEMAND. DELIVERY AND DISCLOSURE HEREOF ARE SOLELY UPON CONDITION THAT THE SAME SHALL NOT BE USED, COPIED OR REPRODUCED, NOR SHALL THE SUBJECT HEREOF BE DISCLOSED IN ANY MANNER FOR ANY PURPOSE, EXCEPT AS HEREIN AUTHORIZED, WITHOUT PRIOR WRITTEN APPROVAL OF CLA-VAL CO. THIS DRAWING IS SUBMITTED CONFIDENTIALLY AND MAY NOT BE USED IN THE MANUFACTURE OF ANY MATERIAL OR PRODUCT OTHER THAN SUCH MATERIALS AND PRODUCTS FURNISHED TO CLA-VAL CO. WHETHER OR NOT THE EQUIPMENT OR INFORMATION SHOWN HEREON IS PATENTED OR OTHERWISE PROTECTED, FULL TITLE AND COPYRIGHTS, IF ANY, IN AND TO THIS DRAWING AND/OR INFORMATION DELIVERED OR SUBMITTED ARE FULLY RESERVED CLA-VAL CO.®



CLA-VAL CO.

NEWPORT BEACH, CALIFORNIA

CATALOG NO.
60-19/660-19

DRAWING NO.
97829

REV.
E

TYPE OF VALVE AND MAIN FEATURES

PUMP CONTROL VALVE WITH
HIGH CAPACITY PILOT SYSTEM

DESIGN

DRAW CH 5-4-79

CHK'D DP 5-7-79

APVD HWE 5-7-79

OPERATING DATA

I. SOLENOID CONTROL FEATURE:

SOLENOID CONTROL (2) IS A DIRECT ACTING, 3-WAY SOLENOID CONTROL THAT CHANGES POSITION WHEN THE COIL IS DE-ENERGIZED OR ENERGIZED. THIS APPLIES OR RELIEVES PRESSURE IN THE COVER CHAMBER OF 3-WAY HYTROLS (3A) AND (3B) WHICH IN TURN APPLIES OR RELIEVES PRESSURE IN THE COVER CHAMBER OF THE MAIN VALVE AND POWERUNIT CHAMBER OF MAIN VALVE PROVIDING THE OPERATION SHOWN IN THE FOLLOWING TABLE:

60E-19/660E-19 SERIES					
SOLENOID CONTROL (2)		3-WAY HYTROLS (3A) & (3B) POSITION	MAIN VALVE COVER CHAMBER	MAIN VALVE POWERROL CHAMBER	MAIN VALVE (1) POSITION
POSITION	PORTS CONNECTED				
ENERGIZED	1 & 2	COM. TO N.O.	PRESSURE RELIEVED	PRESSURE APPLIED	OPEN
DE-ENERGIZED	1 & 3	N.C. TO COM.	PRESSURE APPLIED	PRESSURE RELIEVED	CLOSED

60D-19/660D-19 SERIES					
SOLENOID CONTROL (2)		3-WAY HYTROLS (3A) & (3B) POSITION	MAIN VALVE COVER CHAMBER	MAIN VALVE POWERROL CHAMBER	MAIN VALVE (1) POSITION
POSITION	PORTS CONNECTED				
ENERGIZED	1 & 2	N.C. TO COM.	PRESSURE APPLIED	PRESSURE RELIEVED	CLOSED
DE-ENERGIZED	1 & 3	COM. TO N.O.	PRESSURE RELIEVED	PRESSURE APPLIED	OPEN

NOTE: SOLENOID CONTROL (2) IS EQUIPPED WITH A MANUAL ACTUATOR WHICH CAN BE USED TO OPERATE THE SOLENOID WITHOUT ELECTRICAL POWER. AFTER MANUAL ACTUATION, ALWAYS RETURN THE ACTUATOR TO ITS ORIGINAL POSITION OR THE SOLENOID WILL NOT RETURN TO THE DE-ENERGIZED POSITION.

II. CHECK VALVE FEATURE:

THE MAIN VALVE (1) HAS AN INTEGRAL CHECK FEATURE. WHEN OUTLET PRESSURE EXCEEDS INLET PRESSURE, THE MAIN VALVE CLOSSES PREVENTING REVERSE FLOW

CAD REVISION RECORD - DO NOT REVISE MANUALLY
 BY _____ DATE _____
 DESCRIPTION _____
 LTR _____ SEE SHEET 1.



CLA-VAL CO.

NEWPORT BEACH, CALIFORNIA

CATALOG NO.
60-19/660-19

DRAWING NO.
97829

REV.
E

TYPE OF VALVE AND MAIN FEATURES

PUMP CONTROL VALVE WITH
HIGH CAPACITY PILOT SYSTEM

DESIGN

DRAW CH 5-4-79

CHK'D DP 5-7-79

APVD HWE 5-7-79

OPERATING DATA-CONTINUED

III. DUAL SUPPLY FEATURE:

WHEN MAIN VALVE (1) INLET PRESSURE EXCEEDS OUTLET PRESSURE, SHUTTLE VALVE (4) SHIFTS INTERCONNECTING PORTS "1" AND "2". WHEN MAIN VALVE (1) OUTLET PRESSURE EXCEEDS INLET PRESSURE, SHUTTLE VALVE (4) SHIFTS INTERCONNECTING PORTS "1" AND "3". THIS DIRECTS THE HIGHEST PRESSURE INTO THE PILOT SYSTEM.

IV. OPENING SPEED CONTROL:

CV FLOW CONTROL (6A) CONTROLS THE OPENING SPEED OF THE MAIN VALVE. TURN THE ADJUSTING STEM CLOCKWISE TO MAKE THE MAIN VALVE OPEN SLOWER. DO NOT CLOSE VALVE (6A) COMPLETELY OR THE MAIN VALVE WILL NOT OPEN. (SUGGESTED INITIAL SETTING OF CV FLOW CONTROL IS 1/4 TO 1/2 TURN OPEN.)

V. CLOSING SPEED CONTROL:

CV FLOW CONTROL (6B) CONTROLS THE CLOSING SPEED OF THE MAIN VALVE. TURN THE ADJUSTING STEM CLOCKWISE TO MAKE THE MAIN VALVE CLOSE SLOWER. DO NOT CLOSE VALVE (6B) COMPLETELY OR THE MAIN VALVE WILL NOT CLOSE. (SUGGESTED INITIAL SETTING OF CV FLOW CONTROL IS 1/4 TO 1/2 TURN OPEN.)

VI. SWITCH ASSEMBLY FEATURE:

SWITCH ASSEMBLY (5) IS ACTUATED BY A STEM EXTENSION ATTACHED TO THE MAIN VALVE STEM. THE SWITCH ASSEMBLY IS FACTORY ADJUSTED TO ACTUATE A SINGLE-POLE, DOUBLE-THROW SWITCH WHEN THE MAIN VALVE IS ALMOST CLOSED. WHEN THE MAIN VALVE STARTS TO OPEN, THE SPRING LOADED SWITCH ACTUATING LEVER IS RELEASED AND RETURNS THE SWITCH TO ITS NORMAL POSITION.

VII. OPTIONAL FEATURE OPERATING DATA:

SUFFIX A (FLOW CLEAN STRAINER)

A SELF-CLEANING STRAINER IS INSTALLED IN THE MAIN VALVE INLET AND OUTLET BODY BOSS WHICH PROTECTS THE PILOT SYSTEM FROM FOREIGN PARTICLES.

SUFFIX B (ISOLATION VALVES)

CK2 COCKS (B) ARE USED TO ISOLATE THE PILOT SYSTEM FROM MAIN LINE PRESSURE. THESE VALVES MUST BE OPEN DURING NORMAL OPERATION.

SUFFIX Y (Y-STRAINER)

A Y-PATTERN STRAINER IS INSTALLED IN THE PILOT SUPPLY LINE TO PROTECT THE PILOT SYSTEM FROM FOREIGN PARTICLES. THE STRAINER SCREEN MUST BE CLEANED PERIODICALLY.

CAD REVISION RECORD - DO NOT REVISE MANUALLY

DATE

BY

DESCRIPTION

SEE SHEET 1.

LTR



CLA-VAL CO.

NEWPORT BEACH, CALIFORNIA

CATALOG NO.
60-19/660-19

DRAWING NO.
97829

REV.
E

TYPE OF VALVE AND MAIN FEATURES

PUMP CONTROL VALVE WITH
HIGH CAPACITY PILOT SYSTEM

DESIGN

DRAW CH 5-4-79

CHK'D DP 5-7-79

APVD HWE 5-7-79

OPERATING DATA-CONTINUED

VIII. CHECK LIST FOR PROPER OPERATION:

- () SYSTEM VALVES OPEN UPSTREAM AND DOWNSTREAM.
- () AIR REMOVED FROM THE MAIN VALVE COVER AND PILOT SYSTEM AT ALL HIGH POINTS.
- () CK2 COCKS (B) OPEN (OPTIONAL FEATURE).
- () PERIODIC CLEANING OF STRAINER (Y) IS RECOMMENDED (OPTIONAL FEATURE).
- () CORRECT VOLTAGE TO SOLENOID CONTROL (2).
- () MANUAL OPERATOR OF SOLENOID CONTROL (2) DISENGAGED.

CAD REVISION RECORD - DO NOT REVISE MANUALLY

DATE

BY

DESCRIPTION

SEE SHEET 1.

LTR

"THIS DRAWING IS THE PROPERTY OF CLA-VAL CO. AND SAME AND COPIES MADE THEREOF, IF ANY, SHALL BE RETURNED TO IT UPON DEMAND. DELIVERY AND DISCLOSURE HEREOF ARE SOLELY UPON CONDITION THAT THE SAME SHALL NOT BE USED, COPIED OR REPRODUCED, NOR SHALL THE SUBJECT HEREOF BE DISCLOSED IN ANY MANNER TO ANYONE FOR ANY PURPOSE, EXCEPT AS HEREIN AUTHORIZED, WITHOUT PRIOR WRITTEN APPROVAL OF CLA-VAL CO. THIS DRAWING IS SUBMITTED CONFIDENTIALLY AND MAY NOT BE USED IN THE MANUFACTURE OF ANY MATERIAL OR PRODUCT OTHER THAN SUCH MATERIALS AND PRODUCTS FURNISHED TO CLA-VAL CO. WHETHER OR NOT THE EQUIPMENT OR INFORMATION SHOWN HEREON IS PATENTED OR OTHERWISE PROTECTED, FULL TITLE AND COPYRIGHTS, IF ANY, IN AND TO THIS DRAWING AND/OR INFORMATION DELIVERED OR SUBMITTED ARE FULLY RESERVED CLA-VAL CO."



— MODEL — **100-03**

Powercheck Valve

DESCRIPTION

This manual contains information for installation, operation and maintenance of the Cla-Val 100-03 Powercheck, an automatic valve designed for use where independent operating pressure is desired, or when line fluid is unsuitable as an operating medium.

This valve is a hydraulically operated, diaphragm type, globe or angle pattern valve. It is single seated and incorporates into its design two operating chambers sealed from one another by a flexible synthetic rubber diaphragm. Pressure applied to the upper chamber closes the valve; when applied to the lower chamber, it opens the valve.

With proper pilot controls, the valve can be held in any intermediate position between fully open and tightly closed unless a static condition or pressure reversal occurs, in which case the valve closes to prevent return flow regardless of the diaphragm position.

INSTALLATION

Allow sufficient room around the valve assembly to make adjustments and for disassembly.

NOTE: BEFORE THE VALVE IS INSTALLED, PIPE LINES SHOULD BE FLUSHED OF ALL CHIPS, SCALE AND FOREIGN MATTER.

It is recommended that gate or block valves be installed on both the upstream and downstream sides of the 100-03 to facilitate isolating the valve for preventative maintenance.

Place the valve in the line with flow through the valve in the direction indicated on the inlet name plate or by flow arrows and with the cover "UP". Other positions are not acceptable due to the check feature.

When a pilot control system is installed on the Powercheck Valve, use care to prevent damage. If it is necessary to remove fittings or components, be sure they are kept clean and replaced in the exact order of removal.

After the valve is installed and the system is first pressurized, vent air from the cover chamber and tubing by loosening fittings at all high points.

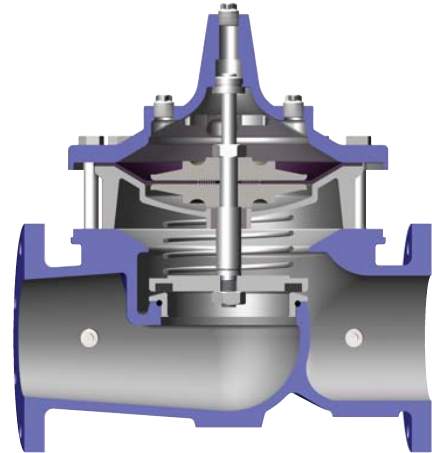

TROUBLE SHOOTING

The following trouble shooting information deals strictly with the Powercheck Valve; however some "possible causes" will refer to components that may exist in the variety of control systems available for the valve. All trouble shooting is possible without removing the valve from the line.

SERVICE SUGGESTIONS

(Service Suggestions Chart)

CAUTION: Extreme care should be taken when servicing the valve. Gate or line block valves must be closed upstream and downstream of the valve before starting disassembly. When there are no block or gate valves to isolate the Powercheck Valve it should be realized that the valve cannot be serviced under pressure. Steps must be taken to remedy this situation before proceeding.

Principle of Operation

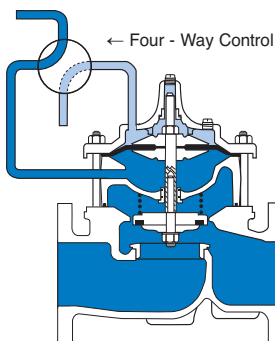

Full Open Operation

When operating pressure below the diaphragm is applied and pressure is relieved from the cover chamber, the valve is held open allowing full flow.

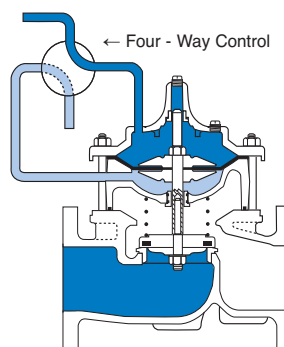

Tight Closing Operation

When pressure below the diaphragm is relieved and operating pressure is applied to the cover chamber, the valve closes drip-tight.

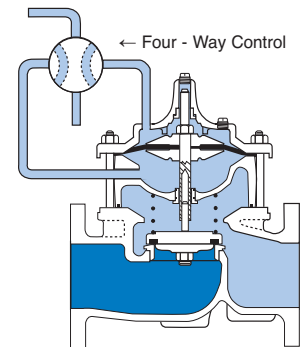

Check Action

When a static condition or pressure reversal occurs, the split stem design allows the valve to instantly check closed. Return flow is prevented regardless of the diaphragm's position.

Note: For optimum operation of built-in check feature, installation with stem vertically up is recommended.

MAINTENANCE

Preventative Maintenance

The Cla Val Powercheck Valves require no lubrication or packing and a minimum of maintenance. However, a periodic inspection schedule should be established to determine how the fluid velocity as well as the substances occurring in natural waters are effecting the valve. These substances can be dissolved minerals, colloidal and suspended particles. Effect of these actions or substances must be determined by inspection.

DISASSEMBLY

First mark the side of the valve cover, power unit body and valve body so that reassembly of these parts will be exact) as removed.

The Powercheck Valve inspection or maintenance can be accomplished without removal of the valve body from the line. Shut off pressure to the valve, both inlet, outlet and independent operating pressure when used.

WARNING: Maintenance personnel can be injured and equipment and property damaged if disassembly is attempted with pressure in the system.

After pressure has been released from the valve control system and operating chambers of the valve, remove the controls and tubing. Obtain a schematic of the assembly or note and sketch position of tubing and controls for reassembly. Replacing tubing into the control ports exactly as removed is necessary. Failure to reassemble properly will cause the valve to malfunction and possibly cause serious damage.

Remove cover nuts and cover. If the valve has been in service for any length of time chances are the cover will have to be loosened by driving upward along the edge of the cover with a dull cold chisel. See Figure 1.

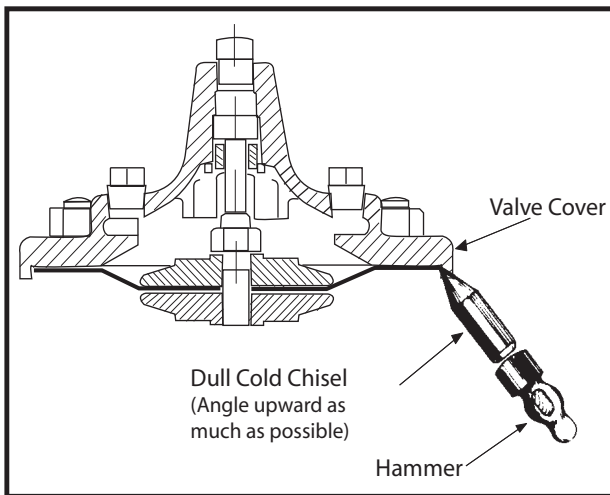

FIGURE 1.

NOTE:

When block and tackle or a power hoist is to be used to lift the valve cover insert a proper size eye bolt in place of the center cover plug. Pull cover straight up to keep from damaging the power unit stem bearing and upper stem.

Power unit body can now be lifted from the valve body. The stem with diaphragm will be removed with the power unit body. The disc retainer assembly with lower stem will separate (check feature) from the upper stem and power unit body.

CAUTION: During service performed on the stem assembly, the stem surfaces must not be damaged. If a vice or other holding device is used to grip the stem, soft jaws of brass or copper must be used to protect the precision ground surface of the stainless steel stem. If the stem is marred no amount of careful dressing can restore the stem to its original condition.

Inspect the threads on the stem. Mineral deposits that prevent the nuts from turning must be cleaned from the threads.

A 5% solution of muriatic acid will soften mineral or scale deposits to assist in removal of nuts and the general cleaning of parts. Flush the parts thoroughly with water immediately after cleaning. Care must always be exercised when handling acid. Read the warning label on the acid container to be sure of correct method of use and disposal after use.

Hold the stem in a vice with soft jaws (see above) when removing the stem nut. Slide off the assembly leaving a completely disassembled upper stem assembly. Remove the disc and disc retainer from the lower stem. Refer to the sectional view of the valve size being serviced. This will assist in the disassembly procedure outlined above. Reassembly instructions outline proper procedure and quantity of spacer washers. This is especially important if the disc is replaced.

Check the upper and lower stems for scale and freedom of movement. Insert the lower stem into the stem (upper). The insertion fully of these parts must be free from binding or resistance. Clean and polish the telescoping parts. Restricted movement of these parts could cause the check feature to fail to function.

Inspection Of Parts

Returning to the valve body in the line, the seat should now be inspected for damage. If the seat requires removal use the following tools. Seats in valve sizes 1/2" and 3/4" can be removed with a hex socket wrench. Seats in valve sizes 1" through 6" should be removed with accessory X-109 Seat Removing Tool available from the factory. Seats in valve sizes 8" through 16" may be removed with a screw driver. If upon removal of the screws the seat cannot be lifted out, it will be necessary to use a hard rubber mallet and tap the seat loose.

Any buildup of mineral or scale should be cleaned from the valve body at this time. Inspection of the cover and power unit body surfaces that contact the diaphragm is important. Clean and smooth, with wet or dry emery paper, any roughness that could damage the diaphragm. Inspect and recondition the surface on the upper and lower diaphragm washers. The perimeter of the diaphragm washers is the most likely area to cause diaphragm wear if the surface is not smooth. Take extra care to make this a smooth finish.

Inspect the power unit body bearing insert O-ring that is in contact with the stem. If it is worn, nicked or cut, replace it.

The cover bearing should also be checked for excessive wear, using the upper end of the stem to check for excessive lateral movement. A special tool for each size valve is available from the factory to remove the cover bearing. Cover bearing replacement is seldom necessary.

Inspect the diaphragm for cracks or chafing. Replace the diaphragm if damaged.

Inspect the disc and replace if the surface is damaged or worn. If a new disc is not available, the existing disc can be turned over, exposing the unused surface for contact with the seat.

The disc guide should be checked and cleaned of scales and mineral deposits. Due to the close tolerance between the outer periphery of the disc guide and the inner area of the valve seat, no scale or mineral deposits should be overlooked.

REASSEMBLY

To reassemble, reverse the order of disassembly

If the disc has been removed, it is important that correct pressure be on the disc from the disc guide when the lower stem nut is tight. Use sufficient spacer washers to obtain slight pressure (by visual indentation) on the disc. Indentation should be slight. Refer to seat and disc detail drawings for location of spacer washers for various valve sizes.

NOTE: New discs will usually require a different number of spacer washers to obtain the right amount of "grip" on the disc.

Place the lower stem assembly onto the seat with the disc in contact with the valve seat. If a large spring (4", 6", 8" only) was removed upon disassembly, replace on top of the disc retainer.

The power unit body with gasket, (body to power unit) or O-ring, can be installed on the body. Be sure the power unit section is replaced exactly in the same position as removed. The end of the lower stem will be visible in the center of the power unit bearing. Care must be taken so the power unit bearing or lower stem is not damaged during this assembly. A hoist may be necessary for large valve sizes.

NOTE: Valves 4" thru 16" use an O-ring body to power unit seal. During placement onto the body apply a light weight grease into the power unit groove to hold the O-ring in place when installing on the body.

Install on the upper stem the lower diaphragm washer, the diaphragm, the upper diaphragm washer, then screw the stem nut and tighten securely so the upper and lower diaphragm washer cannot be turned on the stem. During the tightening of the upper stem nut, the stem should be held in a vice with soft brass jaws. The upper stem and diaphragm assembly can now be lowered into the power unit bearing, the hollow end of the stem sliding on to the end of the lower stem. Move the upper stem and diaphragm assembly up and down to check freedom of movement of the lower and upper stem.

CAUTION: Do not lubricate or grease the hollow end of upper stem or upper end of the lower stem. This could cause the check feature to become inoperative.

Replace cover chamber spring on the upper diaphragm washer.

NOTE: Some valves may not have a cover chamber spring.

Place the cover on the power unit body aligning the index marks. Secure the cover with 8 stud nuts Tighten the nuts firmly with a cross-over pattern until all nuts are tight:

NOTE: Valve sizes 1" thru 3" are bolted with 8 nuts (power unit body to valve body) and 8 nuts (cover to power unit body). Tighten stud nuts firmly with cross-over pattern until all nuts are tight.

When the stem is removed from the valve a tool can be fabricated to check for unrestricted stem movement after reassembly, and also check for correct stem travel. Valves size 1 1/4" thru 24/2" are threaded 10-32 UNF (internal threads) on the top of the stem. Valve sizes 3" and 4" are threaded , 1/4 -28 UNF. Valve sizes 6" thru 14" are threaded 3/4-24 UNF. The 16" valves are threaded, 1/2-20 UNF.

A length of rod threaded on one end can be threaded into the stem through the plug hole in the center of the cover. It is possible with this rod to move the diaphragm assembly up from the seat freely, returning to the seat by its own weight. Larger valve sizes may require a tee handle to assist lifting heavier assemblies. The stroke of the stem should correspond closely with the chart.

Reinstall the control system and tubing exactly as it was before disassembly.

The Powercheck Valve can be tested for tight closure as well as the tightness of the seal across the diaphragm. inlet line pressure, or independent operating pressure can also be used to check the freeness and travel of the diaphragm assembly. Refer to the operation paragraph and principle of operation sectional views for opening and closing operation.

The downstream or outlet shutoff valve remains closed.

If the control system has a pilot or control that can position the valve to a closed position, put the control in a position to close the Powercheck. Lacking a control, inlet pressure must be connected to the cover of the Powercheck Valve.

Open upstream gate or line block valve just enough to allow flow.

Have the power unit body, center section, open to atmosphere. The power unit body will be atmospheric if the control is being used.

Partially disconnect a fitting on the discharge side of the valve. Do not remove fully unless there is no pressure.

After the valve is in the closed position for a few minutes, all draining of the power unit body should stop. This will indicate a good seal across the valve seat and the diaphragm.

USEFUL INFORMATION OR HINTS

1. The approximate volume of liquid discharged from the chamber above the diaphragm when the valve moves from the fully closed position to fully open is as follows:

VALVE SIZE	DISPLACEMENT	
1/2"	0.340 Fl. Oz.	.01 Liters
3/4"	0.340 Fl. Oz.	.01 Liters
1"	0.700 Fl. Oz.	.02 Liters
1 1/4"	0.020 Gal.	.10 Liters
1 1/2"	0.020 Gal.	.10 Liters
2"	0.032 Gal.	.10 Liters
2 1/2"	0.043 Gal.	.20 Liters
3"	0.080 Gal.	.30 Liters
4"	0.169 Gal.	.60 Liters
6"	0.531 Gal.	2.00 Liters
8"	1.260 Gal.	4.75 Liters
10"	2.510 Gal.	9.50 Liters
12"	4.000 Gal.	15.14 Liters
14"	6.500 Gal.	24.60 Liters
16"	9.570 Gal.	36.20 Liters

SERVICE SUGGESTIONS

SYMPTOM	POSSIBLE CAUSE	TEST PROCEDURE	REMEDY
Valve fails to close.	Stem stuck in open position.	Vent power unit chamber. Apply pressure to cover chamber. Valve should close.	Disassemble, examine all internal parts for cause of the sticking condition and clean off scale deposits.
	Worn diaphragm or loose upper stem nut.	Apply pressure in power unit chamber and vent cover. Continuous flow from cover indicates this trouble.	Disassemble and replace diaphragm or tighten the valve stem nut.
	Foreign object on valve seat.	Valve opens okay, but only closes part way.	Try operating valve a few times. This might dislodge the object. If this fails, disassemble and remove the obstruction.
	Pressure not being released from power unit chamber.	Make sure pressure is being released by opening a fitting into the chamber. It valve then closes, refer to remedy.	Check control system. Tube line or nipple might be plugged up.
	Operating pressure not getting into valve cover.	Use pressure gauge or loosen cover plug to check for pressure.	Clean tubing or pipe fittings into cover chamber. Open CK2 Isolation Valve in control lines.
Insufficient line pressure.	Check line pressure.	Establish line pressure.	
Valve fails to open.	Stem stuck in Closed or semiopen position.	Vent cover. Apply pressure to power unit chamber.	Disassemble, examine all internal parts for cause of the sticking problem, and clean off scale deposits.
	Worn diaphragm or loose upper stem nut.	Apply pressure in power unit chamber and vent cover. Continuous flow from cover indicates this problem.	Disassemble and replace diaphragm or tighten valve stem nut.
	Foreign object on top of disc retainer.	Valve closed okay but won't open all the way.	Try operating valve a few times. This might dislodge the object. If this fails, disassemble and remove the obstruction.
	Pressure not being released from cover chamber.	Open a fitting or remove a plug from cover chamber. It cover chamber vents and valve opens, see remedy.	Check control system. Check lines or pipe fittings. Clean out any plugged lines.
	Operating pressure not applied into power unit chamber.	Loosen a fitting in this chamber to check for pressure at this point.	Clean tubing or pipe fittings into power unit chamber.
Valve closes but leakage occurs.	Worn disc or seat.	The best procedure here is to disassemble the valve and inspect these parts.	Replace worn parts.
O-Ring failure.	Mineral deposits on stem cause abrasion on O-ring.	Remove pressure from both cover and power unit chambers and apply line pressure to valve. Open line from power unit chamber and observe continuous flow.	Disassemble and replace O-ring.

FREEDOM OF MOVEMENT

The following procedures can be used to determine if the valve opens and closes fully. During this test the diaphragm can be checked for damage.

The Powercheck Valve will have a control to open and close the valve. Position the control so that pressure is applied to the cover chamber (above the valve diaphragm). This will close the Powercheck Valve. Check the drain from the control that discharges to atmosphere.

Once the liquid from the lower diaphragm chamber is drained the discharge should stop. If the discharge continues after the normal time it takes to drain then the diaphragm is damaged, or the stem nut is loose, or the stem o-ring is leaking. If the discharge is continuous from both chambers then there is a possibility that the diaphragm or the pilot control is damaged.

If the valve is equipped with a "Dry Drain" (control drain piped to downstream end of the valve) then same procedure is followed except the CK2 Shutoff Cock on the downstream end of the valve must be closed and the drain line disconnected and drained to atmosphere. It can then be checked as above.

Measurement of the vertical travel of the stem (diaphragm assembly) will make it possible to determine if the travel, or stroke is restricted. The following chart provides this measurement. It is necessary to have either the X101 Valve Position Indicator or X105 Limit Switch Assembly installed on the valve to visually check the travel.

Mark the position of the stem on the X101 or X105 when the valve is closed. Reposition the control so that pressure is applied below the diaphragm and the cover chamber is drained. Determine the extent of the stem travel. Check this movement with the stem travel chart. If the stroke is different than listed (5% to 10%) then there is good reason to believe something is mechanically restricting the stroke of the valve at one end of its travel. If it is determined that flow does not stop through the valve when in the indicated "closed" position, the obstruction probably is between the disc and the seat, or in the power unit chamber below the diaphragm. If the flow stops, the obstruction is likely in the cover chamber above the diaphragm or possibly above the disc retainer. Refer to the sectional view under Principle of Operation.

If operation of the valve a few times does not dislodge the foreign object obstructing the diaphragm assembly (stem) movement then the valve must be disassembled and the problem located and corrected. See disassembly instructions.

STEM TRAVEL

(fully open to fully closed)

VALVE SIZE		TRAVEL	
INCHES	MM	INCHES	MM
1	25	0.3	8
1 1/4	32	0.4	10
1 1/2	40	0.4	10
2	50	0.6	15
2 1/2	65	0.7	18
3	80	0.8	20
4	100	1.1	23
6	150	1.7	43
8	200	2.3	58
10	250	2.8	71
12	300	3.4	86
14	350	3.9	99
16	400	4.5	114

100-03 Powercheck Valve 1" - 3" Sizes

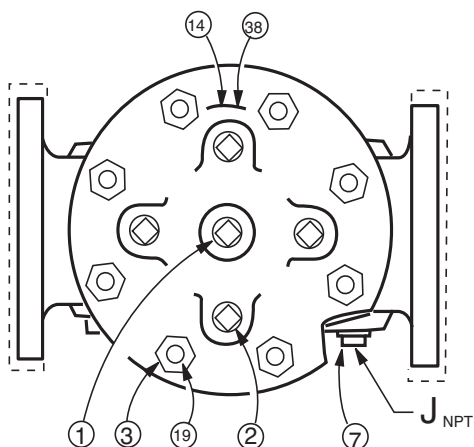
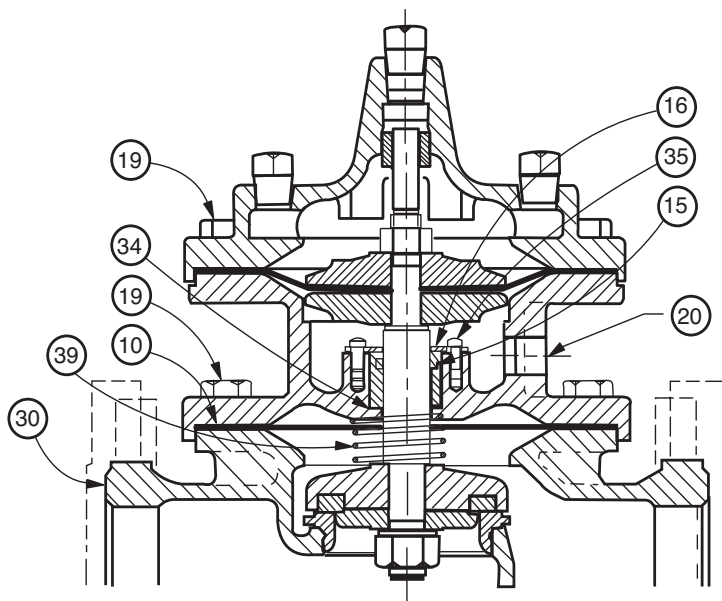

Cover View

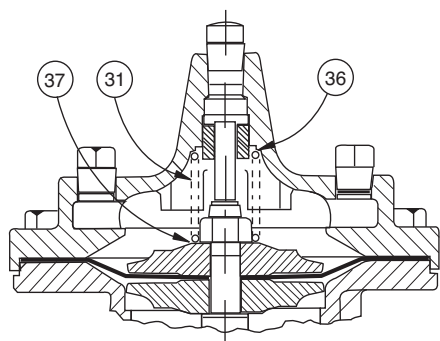

Model 100-03KH

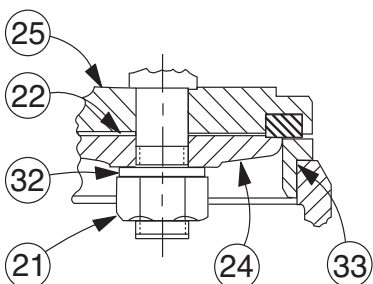

1" - 3"
Seat & Disc Details

ITEM NO.	PART DESCRIPTION	Qty
1	Center Cover Plug	1
2	Cover Plug	A/R
3	Hex Nut (4"-16" only)	A/R
4	Cover Bearing	1
5	Cover	1
6	Pipe Cap (16" only)	1
7	Body Plug	A/R
8	Hex Bolt (16" only)	8
9*	O-Ring (16" only)	1
10*	Gasket (1" - 3" only)	1
11	Upper Stem Nut	1
12	Diaphragm Washer	2
13*	Diaphragm	1
14	Nameplate	1
15*	Stem O-Ring	1
16	Bearing Retainer (1" -3" only)	1
16	Bearing Ring Retainer (4" - 16" only)	1
17	Powerunit Body	1
18*	Bearing O-Ring (4" - 16" only)	1
19	Hex Bolt (1" - 3" only)	A/R
19	Stud (4" - 16" only)	A/R
20	Powerunit Body	1
21	Lower Stem Nut	1
22	Spacer Washer	A/R
23	Screw, Flat Hd (6" - 16" Only)	A/R
24	Disc Guide	1
25	Disc Retainer	1
26*	Disc	1
27	Upper Stem	1
28	Screw, Flat Hd (8" - 16" only)	A/R
29	Seat	1
30	Body	1
31	Spring (100PCKH / 100CAKH only)	1
32	Lockwasher	1
33*	Seat O-Ring	1
34*	Gasket, Bearing (1" - 3" only)	1
35	Screw FIL. Hd (1"-2 1/2" Bolt HX Hd (3"))	4
36	Upper Spring Washer (100PCKCH / 100CAKCH)	1
37	Lower Spring Washer (100PCKCH / 100CAKCH)	1
38	Drive Screw	2
39	Lower Spring (1" - 10" only)	1
40	Lower Stem	1
41	Cover Bearing Housing (16" only)	1
*Recommended Spare Parts		

100-03 Powercheck Valve 4" - 16" Sizes

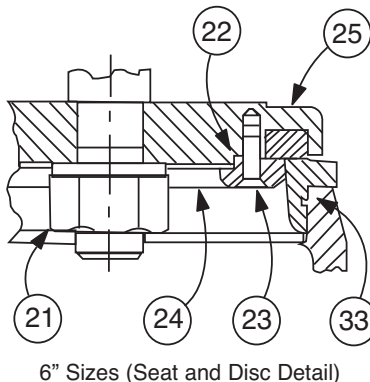
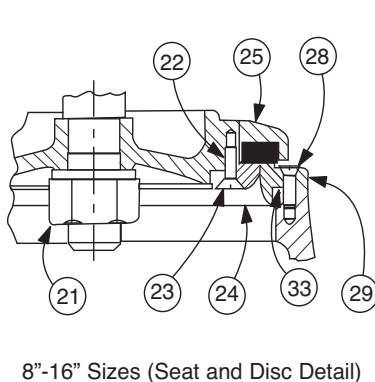
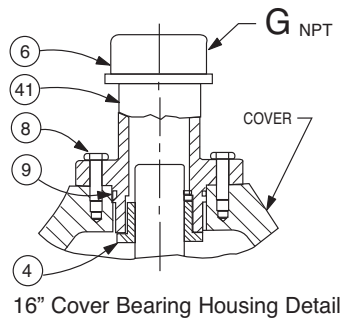
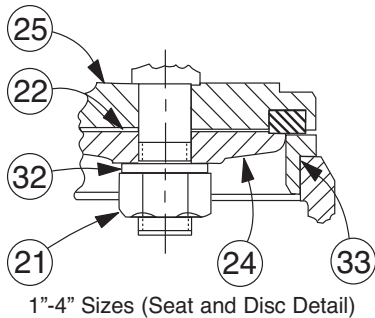
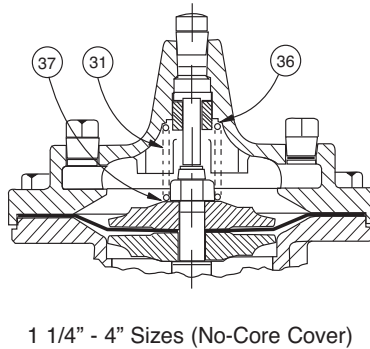
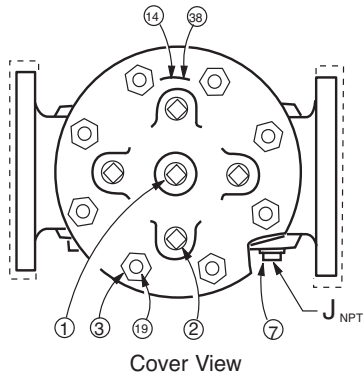
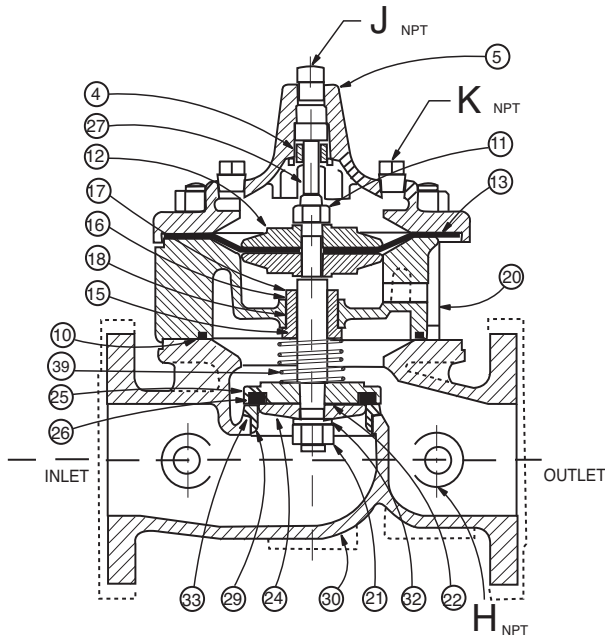

ITEM NO.	PART DESCRIPTION	Qty
1	Center Cover Plug	1
2	Cover Plug	A/R
3	Hex Nut (4" - 16" only)	A/R
4	Cover Bearing	1
5	Cover	1
6	Pipe Cap (16" only)	1
7	Body Plug	A/R
8	Hex Bolt (16" only)	8
9*	O-Ring (16" only)	1
10*	Gasket (1" - 3" only)	1
11	Upper Stem Nut	1
12	Diaphragm Washer	2
13*	Diaphragm	1
14	Nameplate	1
15*	Stem O-Ring	1
16	Bearing Retainer (1" - 3" only)	1
	Bearing Ring Retainer (4" - 16" only)	1
17	Powerunit Body	1
18*	Bearing O-Ring (4" - 16" only)	1
19	Hex Bolt (1" - 3" only)	A/R
	Stud (4" - 16" only)	A/R
20	Powerunit Body	1
21	Lower Stem Nut	1
22	Spacer Washer	A/R
23	Screw, Flat Hd (6" - 16" Only)	A/R
24	Disc Guide	1
25	Disc Retainer	1
26*	Disc	1
27	Upper Stem	1
28	Screw, Flat Hd (8" - 16" only)	A/R
29	Seat	1
30	Body	1
31	Spring (100PCKH / 100CAKH only)	1
32	Lockwasher	1
33*	Seat O-Ring	1
34*	Gasket, Bearing (1" - 3" only)	1
35	Screw FIL. Hd (1"-2 1/2" Bolt HX Hd (3"))	4
36	Upper Spring Washer (100PCKCH / 100CAKCH)	1
37	Lower Spring Washer (100PCKCH / 100CAKCH)	1
38	Drive Screw	2
39	Lower Spring (1" - 10" only)	1
40	Lower Stem	1
41	Cover Bearing Housing (16" only)	1
*Recommended Spare Parts		

Functional Data

Model 100-03

Valve Size		Inches	2½	3	4	6	8	10	12	14	16
		mm.	65	80	100	150	200	250	300	350	400
C _V Factor	Globe Pattern	Gal./Min. (gpm.)	85	115	200	440	770	1245	1725	2300	2940
		Litres/Sec. (l/s.)	20	28	48	106	185	299	414	552	706
	Angle Pattern	Gal./Min. (gpm.)	101	139	240	541	990	1575	2500*	3060*	4200*
		Litres/Sec. (l/s.)	24	33	58	130	238	378	600	734	1008
Equivalent Length of Pipe	Globe Pattern	Feet (ft.)	53	85	116	211	291	347	467	422	503
		Meters (m.)	16	26	35	64	89	106	142	129	154
	Angle Pattern	Feet (ft.)	37	58	80	139	176	217	222*	238*	247*
		Meters (m.)	12	18	25	43	54	66	68	73	75
K Factor	Globe Pattern		4.6	6.0	5.9	6.2	6.1	5.8	6.1	5.0	5.2
	Angle Pattern		3.3	4.1	4.1	4.1	3.7	3.6	2.9	2.8	2.6
Liquid Displaced from Cover Chamber When Valve Opens		Fl. Oz	—	—	—	—	—	—	—	—	—
		U.S. Gal.	.04	.08	.17	.53	1.26	2.51	4.0	6.5	9.6
		ml	163	303	643	—	—	—	—	—	—
		Litres	—	—	—	2.0	4.8	9.5	15.1	24.6	36.2

*Estimated

C_V Factor

Formulas for computing C_V Factor, Flow (Q) and Pressure Drop (ΔP):

$$C_V = \frac{Q}{\sqrt{\Delta P}} \quad Q = C_V \sqrt{\Delta P} \quad \Delta P = \left(\frac{Q}{C_V}\right)^2$$

K Factor (Resistance Coefficient)

The Value of K is calculated from the formula: $K = \frac{894d^4}{C_V^2}$
(U.S. system units)

Equivalent Length of Pipe

Equivalent lengths of pipe (L) are determined from the formula: $L = \frac{Kd}{12f}$
(U.S. system units)

Fluid Velocity

Fluid velocity can be calculated from the following formula: $V = \frac{.4085 Q}{d^2}$
(U.S. system units)

Where:

C_V = U.S. (gpm) @ 1 psi differential at 60° F water
or
= (l/s) @ 1 bar (14.5 PSIG) differential
at 15° C water

d = inside pipe diameter of Schedule 40 Steel Pipe (inches)

f = friction factor for clean, new Schedule 40 pipe
(dimensionless) (from Cameron Hydraulic Data,
18th Edition, P 3-119)

K = Resistance Coefficient (calculated)

L = Equivalent Length of Pipe (feet)

Q = Flow Rate in U.S. (gpm) or (l/s)

V = Fluid Velocity (feet per second) or (meters per second)

ΔP = Pressure Drop in (psi) or (bar)

Model 100-03 Flow Chart (Based on normal flow through a wide open valve)

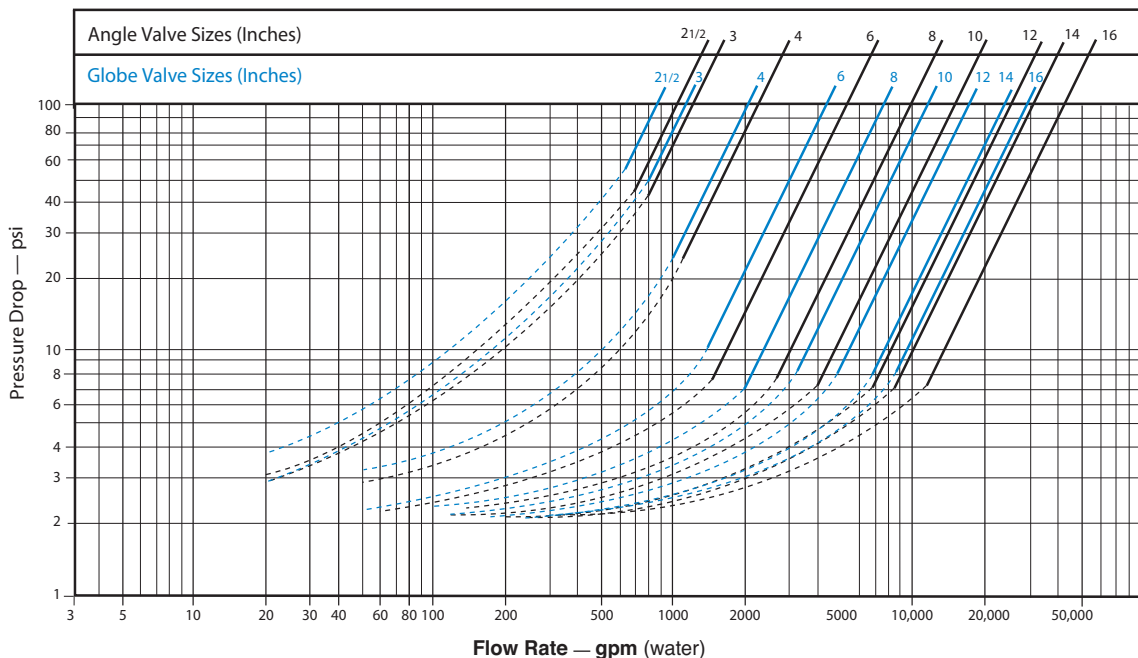

Dimensions

100-03 (Globe)

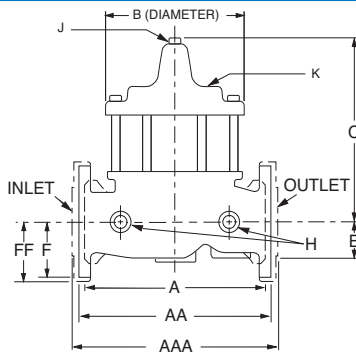

Model 100-03

100-03 (Angle)

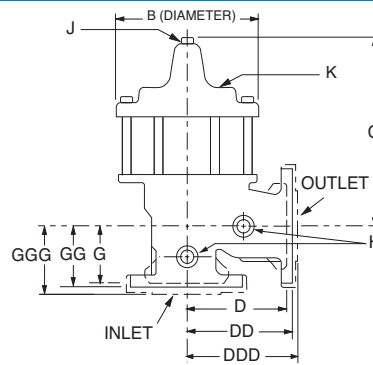

Valve Size (Inches)	2 ½	3	4	6	8	10	12	14	16
A Threaded	11.00	12.50	—	—	—	—	—	—	—
AA 150 ANSI	11.00	12.00	15.00	20.00	25.38	29.75	34.00	39.00	41.38
AAA 300 ANSI	11.62	13.25	15.62	21.00	26.38	31.12	35.50	40.50	43.50
B Dia.	8.00	9.12	11.50	15.75	20.00	23.62	28.00	32.75	35.50
C Max.	10.31	11.19	14.25	18.44	21.81	23.38	29.31	32.12	35.00
D Threaded	5.50	6.25	—	—	—	—	—	—	—
DD 150 ANSI	5.50	6.00	7.50	10.00	12.69	14.88	17.00	19.50	20.69
DDD 300 ANSI	5.81	6.63	7.81	10.50	13.19	15.56	17.75	20.25	21.75
E	1.69	2.06	3.19	4.31	5.31	9.25	10.75	12.62	15.50
F 150 ANSI	3.50	3.75	4.50	5.50	6.75	8.00	9.50	10.50	11.75
FF 300 ANSI	3.75	4.13	5.00	6.25	7.50	8.75	10.25	11.50	12.75
G Threaded	4.00	4.50	—	—	—	—	—	—	—
GG 150 ANSI	4.00	4.00	5.00	6.00	8.00	8.62	13.75	14.88	15.69
GGG 300 ANSI	4.31	4.38	5.31	6.50	8.50	9.31	14.50	15.62	16.50
H NPT Body Tapping	½	½	¾	¾	1	1	1	1	1
J NPT Cover Center Plug	½	½	¾	¾	1	1	1¼	1½	2
K NPT Cover Tapping	½	½	¾	¾	1	1	1	1	1
Valve Stem Internal Thread UNF	10-32	¼-28	¼-28	¾-24	¾-24	¾-24	¾-24	¾-24	½-20
Stem Travel	0.7	0.8	1.1	1.7	2.3	2.8	3.4	4.0	4.5
Approx. Ship Wt. Lbs.	65	95	190	320	650	940	1675	2460	3100

Valve Size (mm)	65	80	100	150	200	250	300	350	400
A Threaded	279	318	—	—	—	—	—	—	—
AA 150 ANSI	279	305	381	508	645	756	864	991	1051
AAA 300 ANSI	295	337	397	533	670	790	902	1029	1105
B Dia.	203	232	292	400	508	600	711	832	902
C Max.	262	284	362	468	554	594	744	816	889
D Threaded	140	159	—	—	—	—	—	—	—
DD 150 ANSI	140	152	191	254	322	378	432	495	526
DDD 300 ANSI	148	168	198	267	335	395	451	514	552
E	43	52	81	109	135	235	273	321	394
F 150 ANSI	89	95	114	140	171	203	241	267	298
FF 300 ANSI	95	105	127	159	191	222	260	292	324
G Threaded	102	114	—	—	—	—	—	—	—
GG 150 ANSI	102	102	127	152	203	219	349	378	399
GGG 300 ANSI	110	111	135	165	216	236	368	397	419
H NPT Body Tapping	½	½	¾	¾	1	1	1	1	1
J NPT Cover Center Plug	½	½	¾	¾	1	1	1¼	1½	2
K NPT Cover Tapping	½	½	¾	¾	1	1	1	1	1
Valve Stem Internal Thread UNF	10-32	¼-28	¼-28	¾-24	¾-24	¾-24	¾-24	¾-24	½-20
Stem Travel	18	20	28	43	58	71	86	102	114
Approx. Ship Wt. Kgs.	30	43	86	145	295	426	760	1116	1406

Cla-Val Control Valves operate with maximum efficiency when mounted in horizontal piping with the main valve cover UP, however, other positions are acceptable. Due to component size and weight of 8 inch and larger valves, installation with cover UP is advisable. We recommend isolation valves be installed on inlet and outlet for maintenance. Adequate space above and around the valve for service personnel should be considered essential. A regular maintenance program should be established based on the specific application data. However, we recommend a thorough inspection be done at least once a year. Consult factory for specific recommendations.



— MODEL —

100-22

600 Series

Powercheck Valve



- Built-in Automatic Check Valve
- Reduced Cavitation Design
- Service Without Removal From Line
- Packless Construction
- Drip-Tight and Positive Seating

The Cla-Val Model 100-22 Powercheck Valve is a hydraulically operated diaphragm valve with a built-in check feature to prevent return flow. Available in globe or angle pattern, it consists of four major components: the body, intermediate chamber, diaphragm assembly and cover. The diaphragm assembly is the only moving part.

The diaphragm assembly which is guided top, center and bottom by a precision machined stem utilizes an FDA approved non-wicking diaphragm of nylon fabric bonded with synthetic rubber. A synthetic rubber disc retained on three and one-half sides forms a drip-tight seal with the renewable seat when pressure is applied above the diaphragm. When pressure above the diaphragm is relieved, the valve opens wide. The rate of closing or opening can be controlled by modulating the flow into or out of the cover chamber. When a pressure reversal occurs the valve will immediately close, preventing reverse flow through the valve. The split stem will allow the disc retainer assembly to check closed **regardless of the position of the diaphragm.**

The Model 100-22 Powercheck Valve is recommended on system applications where a positive check feature is necessary to prevent reverse flow.



see page 2 for approvals

Principle of Operation

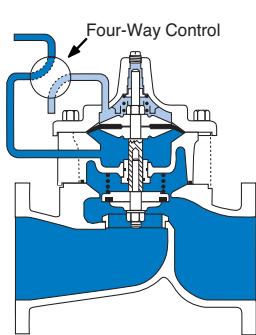

Full Open Operation

When operating pressure below the diaphragm is greater than the pressure in the cover chamber, the valve is held open, allowing full flow.

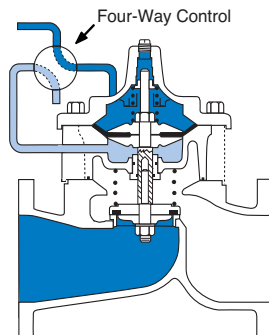

Tight Closing Operation

When pressure below the diaphragm is relieved and operating pressure is applied to the cover chamber, the valve closes drip-tight.

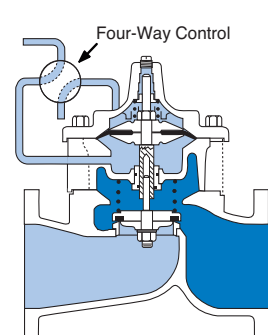

Check Action

When a static condition or pressure reversal occurs, the split stem allows the valve to instantly check closed. Return flow is prevented regardless of the diaphragm's position.

Note: For optimum operation of built-in check feature, installation with stem vertically up is recommended.

Cla-Val 100-22 Powercheck Main Valve Specifications

Available Sizes

Pattern	Flanged
Globe (inches)	4" - 24"
Globe (mm)	100 - 600 mm
Angle (inches)	4", 6", 8"
Angle (mm)	100, 150 and 200 mm

Operating Temp. Range

Fluids
-40° to 180° F -40° to 82° C



4" Globe, Flanged



6" Globe, Flanged

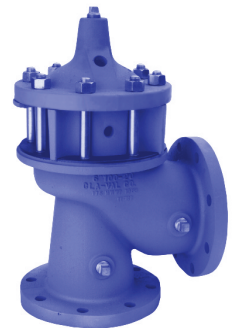

6" Angle, Flanged

Pressure Ratings (Recommended Maximum Pressure - psi)

Valve Body & Cover		Pressure Class		
		Flanged		
Grade	Material	ANSI Standards*	150 Class	300 Class
ASTM A536	Ductile Iron	B16.42	250	400
ASTM A216-WCB	Cast Steel	B16.5	285	400
UNS 87850	Bronze	B16.24	225	400

Note: * ANSI standards are for flange dimensions only.
Flanged valves are available faced but not drilled.
Valves for higher pressure are available; consult factory for details

Materials

Component	Standard Material Combinations		
Body & Cover	Ductile Iron	Cast Steel	Bronze
Available Sizes (inches)	4" - 24"	4" - 16"	4" - 16"
Available Sizes (mm)	100 - 600 mm	100 - 400 mm	100 - 400 mm
Disc Retainer & Diaphragm Washer	Cast Iron	Cast Steel	Bronze
Trim: Disc Guide, Seat & Cover Bearing	Bronze is Standard Stainless Steel is optional		
Disc	Buna-N® Rubber		
Diaphragm	Nylon Reinforced Buna-N® Rubber		
Stem, Nut & Spring	Stainless Steel		

For material options not listed, consult factory.
Cla-Val manufactures valves in more than 50 different alloys.

Options

Epoxy Coating - suffix KC

An FDA approved fusion bonded epoxy coating for use with cast iron, ductile iron or steel valves. This coating is resistant to various water conditions, certain acids, chemicals, solvents and alkalis. Epoxy coatings are applied in accordance with AWWA coating specifications C116-03. Do not use with temperatures above 175°F/ 80° C.

Viton® Rubber Parts - suffix KB

Optional diaphragm, disc and o-ring fabricated with Viton® synthetic rubber. Viton® is well suited for use with mineral acids, salt solutions, chlorinated hydrocarbons, and petroleum oils; and is primarily used in high temperature applications up to 250° F/120°C. Do not use with epoxy coating above 175°F/80° C.

For assistance in selecting appropriate valve options or valves manufactured with special design requirements, please contact our Regional Sales Office or Factory.

Approvals



NSF/ANSI 372: National Lead Free Mandate "Reduction of Lead in Drinking Water Act"



NSF International recognizes Cla-Val as complying with NSF/ANSI 61 and all applicable requirements.

Valve Size		Inches	4	6	8	10	12	14	16	18	20	24
		mm.	100	150	200	250	300	350	400	460	500	600
C _V Factor	Globe Pattern	Gal./Min. (gpm.)	136	229	480	930	1458	1725	2110	2940	3400*	4020
		Litres/Sec. (l/s.)	32.5	55	115	223	350	414	506	705	816	965
	Angle Pattern	Gal./Min. (gpm.)	135	233	545	—	—	—	—	—	—	—
		Litres/Sec. (l/s.)	32	56	132	—	—	—	—	—	—	—
Equivalent Length of Pipe	Globe Pattern	Feet (ft.)	251	777	748	621	654	750	977	983	1125	3005
		Meters (m.)	76.4	237.1	228.1	189.5	199.4	228.7	298.1	299.9	343.2	916.6
	Angle Pattern	Feet (ft.)	254	751	580	—	—	—	—	—	—	—
		Meters (m.)	77.6	229	176.9	—	—	—	—	—	—	—
K Factor	Globe Pattern		12.7	23.1	15.7	10.4	8.5	8.9	10.2	8.4	8.8	19.1
	Angle Pattern		12.9	22.3	12.2	—	—	—	—	—	—	—
Liquid Displaced from Cover Chamber When Valve Opens	Fl. Oz		—	—	—	—	—	—	—	—	—	—
	U.S. Gal.		.08	.17	.53	1.26	2.51	4.0	4.0	9.6	9.6	9.6
	ml		—	—	—	—	—	—	—	—	—	—
	Litres		.30	.64	2.0	4.8	9.5	15.1	15.1	36.2	36.2	36.2

*Estimated

C_V Factor

Formulas for computing C_V Factor, Flow (Q) and Pressure Drop (ΔP):

$$C_V = \frac{Q}{\sqrt{\Delta P}} \quad Q = C_V \sqrt{\Delta P} \quad \Delta P = \left(\frac{Q}{C_V} \right)^2$$

K Factor (Resistance Coefficient)

The Value of K is calculated from the formula: $K = \frac{894d^4}{C_V^2}$ (U.S. system units)

Equivalent Length of Pipe

Equivalent lengths of pipe (L) are determined from the formula: $L = \frac{Kd}{12f}$ (U.S. system units)

Fluid Velocity

Fluid velocity can be calculated from the following formula: $V = \frac{.4085 Q}{d^2}$ (U.S. system units)

Where:

C_V = U.S. (gpm) @ 1 psi differential at 60° F water or

= (l/s) @ 1 bar (14.5 PSIG) differential at 15° C water

d = inside pipe diameter of Schedule 40 Steel Pipe (inches)

f = friction factor for clean, new Schedule 40 pipe (dimensionless) (from Cameron Hydraulic Data, 18th Edition, P 3-119)

K = Resistance Coefficient (calculated)

L = Equivalent Length of Pipe (feet)

Q = Flow Rate in U.S. (gpm) or (l/s)

V = Fluid Velocity (feet per second) or (meters per second)

ΔP = Pressure Drop in (psi) or (bar)

Model 100-22 Flow Chart (Based on normal flow through a wide open valve)

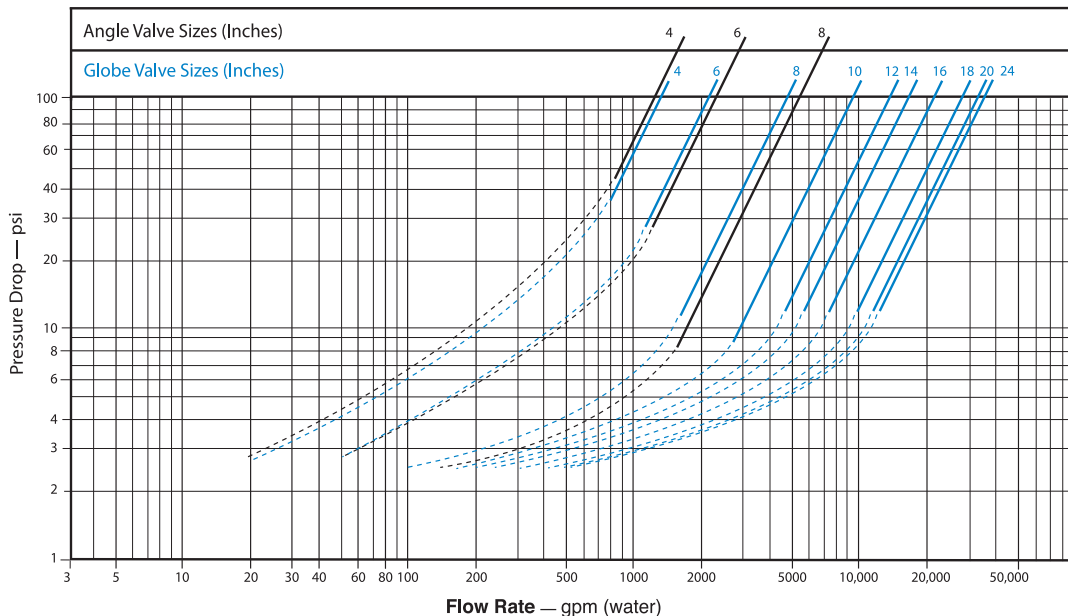

Cla-Val 100-22 Powercheck Main Valve Dimensions

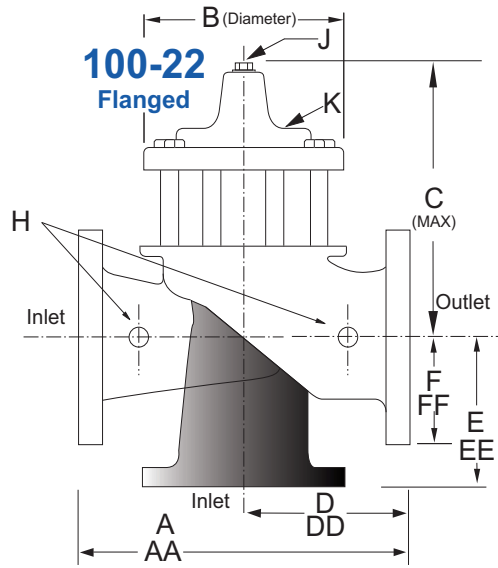

Valve Size (Inches)	4	6	8	10	12	14	16	18	20	24
A 150 ANSI	13.88	17.75	21.38	26.00	30.00	34.25	35.00	42.12	48.00	48.00
AA 300 ANSI	14.50	18.62	22.38	27.38	31.50	35.75	36.62	43.62	49.62	49.75
B Diameter	9.12	11.50	15.75	20.00	23.62	28.00	28.00	35.44	35.44	35.44
C Maximum	11.75	15.25	20.25	23.75	27.25	29.31	34.12	35.00	40.25	40.25
D 150 ANSI	6.94	8.88	10.69	—	—	—	—	—	—	—
DD 300 ANSI	7.25	9.38	11.19	—	—	—	—	—	—	—
E 150 ANSI	5.50	6.75	7.25	—	—	—	—	—	—	—
EE 300 ANSI	5.81	7.25	7.75	—	—	—	—	—	—	—
F 150 ANSI	4.50	5.50	6.75	8.00	9.50	11.00	11.75	15.88	14.56	17.00
FF 300 ANSI	5.00	6.25	7.50	8.75	10.25	—	12.75	15.88	16.06	19.00
H NPT Body Tapping	0.50	0.75	0.75	1.00	1.00	1.00	1.00	1.00	1.00	1.00
J NPT Cover Center Plug	0.50	0.75	0.75	1.00	1.00	1.25	1.25	2.00	2.00	2.00
K NPT Cover Tapping	0.50	0.75	0.75	1.00	1.00	1.00	1.00	1.00	1.00	1.00
Stem Travel	0.80	1.10	1.70	2.30	2.80	3.40	3.40	4.50	4.50	4.5
Approx. Ship Weight (lbs)	135	230	480	785	1410	2215	2215	2300	3400	3600

Valve Size (mm)	100	150	200	250	300	350	400	450	500	600
A 150 ANSI	353	451	543	660	762	870	889	1070	1219	1219
AA 300 ANSI	368	473	568	695	800	—	930	1108	1260	1263
B Diameter	232	292	400	508	600	711	711	900	900	900
C Maximum	298	387	514	603	692	744	867	889	1022	1022
D 150 ANSI	176	226	272	—	—	—	—	—	—	—
DD 300 ANSI	184	238	284	—	—	—	—	—	—	—
E 150 ANSI	140	171	184	—	—	—	—	—	—	—
EE 300 ANSI	148	184	197	—	—	—	—	—	—	—
F 150 ANSI	114	140	171	203	241	279	298	403	370	432
FF 300 ANSI	127	159	191	222	260	—	324	403	408	483
H NPT Body Tapping	0.50	0.75	0.75	1.00	1.00	1.00	1.00	1.00	1.00	1.00
J NPT Cover Center Plug	0.50	0.75	0.75	1.00	1.00	1.25	1.25	2.00	2.00	2.00
K NPT Cover Tapping	0.50	0.75	0.75	1.00	1.00	1.00	1.00	1.00	1.00	1.00
Stem Travel	20	28	43	58	71	86	86	86	114	114
Approx. Ship Weight (kgs)	61	104	218	356	640	1006	1006	1044	1544	1634

Cla-Val Control Valves operate with maximum efficiency when mounted in horizontal piping with the main valve cover UP, however, other positions are acceptable. Due to component size and weight of 10 inch and larger valves, installation with cover UP is advisable. We recommend isolation valves be installed on inlet and outlet for maintenance. Adequate space above and around the valve for service personnel should be considered essential. A regular maintenance program should be established based on the specific application data. However, we recommend a thorough inspection be done at least once a year. Consult factory for specific recommendations.

INSTALLATION AND MAINTENANCE INSTRUCTIONS

3-WAY SOLENOID VALVES, NORMALLY OPEN NORMALLY CLOSED AND UNIVERSAL CONSTRUCTION

**BULLETIN
8320**

ASCO
FORM NO. V5291R2

DESCRIPTION

Bulletin 8320 is a small 3-way solenoid operated valve with all three pipe connections located in the body. The bodies are of brass or stainless steel construction. Standard valves have General Purpose, Nema Type 1 Solenoid Enclosures. Valves that are equipped with a solenoid enclosure which is designed to meet Nema Type 4-Water tight, Nema Type 7 (C or D) Hazardous Locations - Class I, Group C or D, and Nema Type 9 (E, F or G) Hazardous Locations - Class II, Group E, F or G are shown on separate sheets of Installation and Maintenance Instructions, Form Numbers V-5391 and V-5381.

MANUAL OPERATORS (OPTIONAL)

Valves with suffix "MO" or "MS" in catalog number are provided with a Manual Operator which allows manual operation when desired or during an interruption of electrical power.

OPERATION

Normally Closed: Applies pressure when solenoid is energized; exhausts pressure when solenoid is de-energized

Normally Open: Applies pressure when solenoid is de-energized; exhausts pressure when solenoid is energized.

Universal: For normally closed or normally open operation, selection or diversion of pressure can be applied at port 1 (A), 2 (B), or 3 (C).

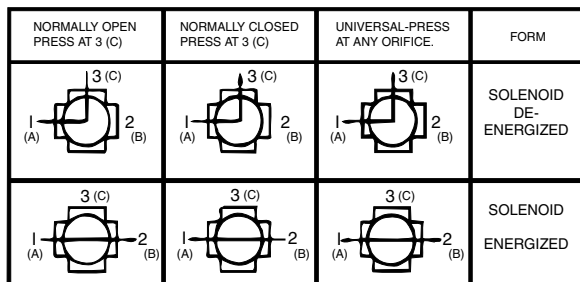

NOTE: Port Markings 1, 2, and 3 correspond directly to A, B and C.

INSTALLATION

Check Nameplate for correct Catalog Number, pressure, voltage and service.

POSITIONING

Valve may be mounted in any position

PIPING

Connect piping to valve according to markings on valve body. Refer to Flow Diagram provided. Apply pipe compound sparingly to male pipe threads only; if applied to valve threads, it may enter valve and cause operational difficulty. Pipe strain should be avoided by proper support and alignment of piping. When tightening pipe, do not use valve as lever.

IMPORTANT: For protection of the solenoid valve, install a strainer or filter suitable for the service involved in the inlet side as close to the valve as possible. Periodic cleaning is required depending on the service conditions.

WIRING

Wiring must comply with local and National Electrical Codes. For valves equipped with an explosion-proof, watertight solenoid enclosure, the electrical fittings must be approved for use in the approved hazardous locations. Housings for all solenoids are made with connections for 1/2 inch conduit. The general purpose enclosure may be rotated to facilitate wiring by removing the retaining cap.

NOTE

Alternating Current (A-C) and Direct Current (D-C) solenoids are built differently. To convert from one to other, it is necessary to change the complete solenoid, including the core assembly.

SOLENOID TEMPERATURE

Standard catalog valves are supplied with coils designed for continuous duty service. When the solenoid is energized for a long period, the solenoid enclosure becomes hot and can be touched with the bare hand for only an instant. This safe operating temperature. Any excessive heating will be indicated by the smoke and odor of burning coil insulation.

MAINTENANCE

WARNING: Turn off electrical power and line pressure to valve before making repairs. It is not necessary to remove valve from pipe line for repairs.

CLEANING

A periodic cleaning of all valves is desirable. The time between cleanings will vary, depending on the media and service conditions. In general, if the voltage to the coils is correct, sluggish valve operation or excessive leakage will indicate that cleaning is required.

IMPROPER OPERATION

1. **Faulty Control Circuit:** Check the electrical system by energizing the solenoid. A metallic click signifies the solenoid is operating. Absence of the click indicate loss of power supply. Check for loose or blown-out fuses, open-circuited or grounded coil, broken lead wires or splice.
2. **Burned-out Coil:** Check for open-circuited coil. Replace coil, if necessary.
3. **Low Voltage:** Check voltage across coil leads. Voltage must be at least 85% of nameplate ratings.
4. **Incorrect Pressure:** Check valve pressure. Pressure to valve must be within the range specified on nameplate.
5. **Excessive Leakage:** Disassemble valve and clean all parts. Replace parts that are worn or damaged with a complete Spare Parts Kit for best results.

COIL REPLACEMENT (REF. FIG. 2)

Turn off electrical power, disconnect coil lead wires and proceed as follows:

1. Remove retaining cap, nameplate and cover.
2. Slip yoke containing coil, sleeves and insulating washers off the solenoid base sub-assembly. Insulating washers are omitted when molded coil is used. In some D.C. Constructions, a single flux plate over the coil replaces yoke, sleeves and insulating washers.
3. Reassemble in reverse order of disassembly.

VALVE DISASSEMBLY AND REASSEMBLY (REF. FIG. 2)

Turn off electrical power supply and de-pressurize valve.

1. Remove retaining cap and slip entire solenoid off solenoid base subassembly or plugnut/core tube sub-assembly.
2. Unscrew bonnet or solenoid base sub-assembly. Remove core assembly, core spring and body gasket.
3. Remove end cap, body gasket, disc spring, disc holder, disc or disc holder assembly.
4. All parts are now accessible for cleaning or replacement. Replace worn or damaged parts with a complete Spare Parts Kit for best results.
5. Reassemble in reverse order of disassembly paying careful attention to exploded view provided.

ORDERING INFORMATION FOR SPARE PARTS KITS

When Ordering Spare Parts Kits or Coils
Specify Valve Catalog Number,
Serial Number and Voltage

Spare Parts Kits and Coils are available for ASCO valves. Parts marked with

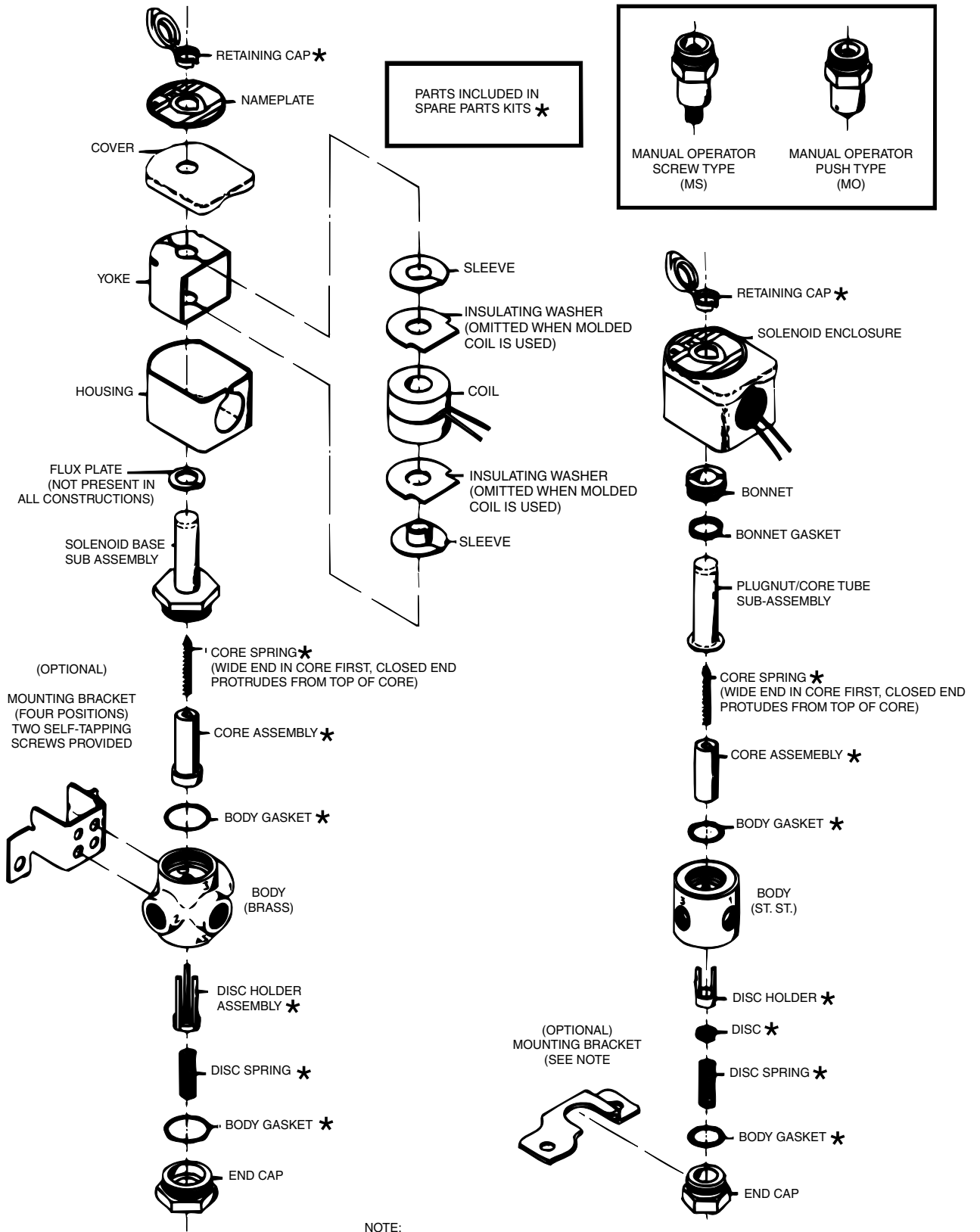

NOTE:
1. FOR MOUNTING, A FLAT SURFACE MUST BE PROVIDED ACROSS THE ENTIRE LENGTH OF THE BRACKET. THE VALVE BODY BECOMES SECURE TO BRACKET, WHEN BRACKET IS TIGHTENED IN TO POSITION. IF THE VALVE HAS A MANUAL OPERATOR, A HOLE MUST BE MADE THROUGH THE MOUNTING SURFACE FOR THE OPERATOR STEM.

INSTALLATION AND MAINTENANCE INSTRUCTIONS

OPEN-FLAME, GENERAL PURPOSE, WATERTIGHT/EXPLOSIONPROOF SOLENOIDS

**BULLETIN
8016G**

ASCO
FORM NO. V6583R5

-SERVICE NOTICE-

ASCO® solenoid valves with design change letter "G" in the catalog number (example: 8210G 1) have an epoxy encapsulated ASCO® Red Hat II. solenoid. This solenoid replaces some of the solenoids with metal enclosures and open-frame constructions. Follow these installation and maintenance instructions if your valve or operator uses this solenoid.

DESCRIPTION

Catalog numbers 8016G1 and 8016G2 are epoxy encapsulated pull-type solenoids. The green solenoid with lead wires and 1/2" conduit connection is designed to meet Enclosure Type 1 -General Purpose, Type 2-Dripproof, Types 3 and 3S-Raintight, and Types 4 and 4X-Watertight. The black solenoid on catalog numbers prefixed "EF" is designed to meet Enclosure Types 3 and 3S-Raintight, Types 4 and 4X-Watertight, Types 6 and 6P-Submersible, type 7 (A, B, C, & D) Explosionproof Class 1, Division 1, Groups A, B, C, & D and Type 9 (E, F, & G)-Dust-Ignitionproof Class 11, Division 1, Groups E, F, & G. The Class 11, Groups F & G Dust Locations designation is not applicable for solenoids or solenoid valves used for steam service or when a class "H" solenoid is used. See Temperature Limitations section for solenoid identification and nameplate/retainer for service. When installed just as a solenoid and not attached to an ASCO valve, the core has a .250-28 UNF-2B tapped hole, 0.38 minimum full thread.

Series 8016G solenoids are available in:

- **Open-Frame Construction**
The green solenoid may be supplied with 1/4" spade, screw, or DIN terminals (Refer to Figure 4).
- **Panel Mounted Construction**
These solenoids are specifically designed to be panel mounted by the customer through a panel having a .062 to .093 maximum wall thickness. (Refer to Figure 3 and section on Installation of Panel Mounted Solenoid).

Optional Features For Type 1—General Purpose Construction Only

- **Junction Box**
This junction box construction meets Enclosure Types 2,3,3S,4, and 4X. Only solenoids with 1/4" spade or screw terminals may have a junction box. The junction box provides a 1/2" conduit connection, grounding and spade or screw terminal Connections within the junction box (See Figure 5).
- **DIN Plug Connector Kit No. K236 - 034**
Use this kit only for solenoids with DIN terminals. The DIN plug connector kit provides a two pole with grounding contact DIN Type 43650 construction (See Figure 6).

OPERATION

When the solenoid is energized, the core is drawn into the solenoid base sub-assembly. **IMPORTANT:** When the solenoid is de-energized, the initial return force for the core, Whether developed by spring, pressure, or weight, must exert a minimum force to overcome residual magnetism created by the solenoid. Minimum return force for AC construction is 11 ounces, and 4 ounces for DC construction.

INSTALLATION

Check nameplate for correct catalog number, service, and wattage. Check front of solenoid for voltage and frequency.

WARNING: To prevent the possibility of electrical shock from the accessibility of live parts, install the open-frame solenoid in an enclosure.

FOR BLACK ENCLOSURE TYPES 7 AND 9 ONLY

CAUTION: To prevent fire or explosion, do not install solenoid and/or valve where ignition temperature is less than 165° C. On valves used for steam service or when a class "H" solenoid is used, do not install in hazardous atmosphere where ignition temperature is less than 180° C. See nameplate/retainer for service. **NOTE:** These solenoids have an internal non-resettable thermal fuse to limit solenoid temperature in the event that extraordinary conditions occur which could cause excessive temperatures. These conditions include high input voltage, a jammed core, excessive ambient temperature or shorted solenoid, etc. This unique feature is a standard feature only in solenoids with black explosionproof/dust-ignitionproof enclosures (types 7&9).

IMPORTANT: To protect the solenoid valve or operator, install a strainer or filter, suitable for the service involved in the inlet side as close to the valve or operator as possible. Clean periodically depending on service condition & See ASCO Series 8600, 8601, and 8602 for strainers.

Temperature Limitations

For maximum valve ambient temperatures, refer to chart. The temperature limitations listed, only indicate maximum application temperatures for field wiring rated at 90°C. Check catalog number prefix and watt rating on nameplate to determine maximum ambient temperature. See valve installation and maintenance instructions for maximum fluid temperature. **NOTE:** For steam service, refer to Wiring section, Junction Box for temperature rating of supply wires.

Temperature Limitations For Series 8016G Solenoids for use Valves Rated at 6.1, 8.1,9.1,10.6 or 11.1 Watts			
Watts Rating	Catalog Number Coil prefix	Class of Insulation	Maximum ambient Temp. °F
6.1, 8.1, 9.1, & 11.1	None, FB, KF, KP, SF, SP, SC, & SD	F	125
6.1, 8.1, 9.1, & 11.1	HB, HT, KB, KH, SS, ST, SU, & ST	H	140
10.6	None, KF, SF, & SC	F	104
10.6	HT, KH, SU, & ST	H	104

Minimum ambient temperature -40° F (-40° C); Positioning

Positioning

This solenoid is designed to perform properly when mounted in any position. However, for optimum life and performance, the solenoid should be mounted vertically and upright to reduce the possibility of foreign matter accumulating in the solenoid base sub-assembly area.

Wiring

Wiring must comply with local codes and the National Electrical Code. All solenoids supplied with lead wires are provided with a grounding wire which is green or green with yellow stripes and a 1/2" conduit connection. To facilitate wiring, the solenoid may be rotated 360°. For the watertight and explosionproof solenoid, electrical fittings must be approved for use in the approved hazardous locations.

Additional Wiring Instructions For Optional Features:

- **Open-Frame solenoid with 1/4" spade terminals**
For solenoids supplied with screw terminal connections use #12-18 AWG stranded copper wire rated at 90°C or greater. Torque terminal block screws to 10 ± 2 in-lbs (1.0 + 1.2 Nm). A tapped hole is provided in the solenoid for grounding, use a #Y10-32 machine screw. Torque grounding screw to 15 -20

in-lbs (1,7 - 2,3 Nm). On solenoids with screw terminals, the socket head screw holding the terminal block to the solenoid is the grounding screw. Torque the screw to 15 - 20 in-lbs (1,7 - 2,3 Nm). with a 5/32" hex key wrench.

• Junction Box

The junction box is used with spade or screw terminal solenoids only and is provided with a grounding screw and a 1/2" conduit connection. Connect #12-18AWG standard copper wire only to the screw terminals. Within the junction box use field wire that is rated 90°C or greater for connections. For steam service use 105°C rated wire up to 50 psi or use 125°C rated wire above 50 psi. After electrical hookup, replace cover gasket, cover, and screws. Tighten screws evenly in a crisscross manner.

• DIN Plug Connector Kit No. KC236-034

1. The open—frame solenoid is provided with DIN terminals to accommodate the DIN plug connector kit.
2. Remove center screw from plug connector. Using a small screwdriver, pry terminal block from connector cover.
3. Use #12-18 AWG stranded copper wire rated at 90°C or greater for connections. Strip wire leads back approximately 1/4" for installation in socket terminals. The use of wire-end sleeves is also recommended for these socket terminals. Maximum length of wire-end sleeves to be approximately 1/4". Tinning of the ends of the lead wires is not recommended.
4. Thread wire through gland nut, gland gasket, washer, and connector cover.

NOTE: Connector cover may be rotated in 90° increments from position shown for alternate positioning of cable entry.

5. Check DIN connector terminal block for electrical markings. Then make electrical hookup to terminal block according to markings on it. Snap terminal block into connector cover and install center screw.
6. Position connector gasket on solenoid and install plug connector. Torque center screw to 5 ± 1 in-lbs ($0,6 \pm 1,1$ Nm).

NOTE: Alternating current (AC) and direct current (DC) solenoids are built differently. To convert from one to the other, it may be necessary to change the complete solenoid including the core and solenoid base sub-assembly, not just the solenoid. Consult ASCO.

Installation of Solenoid

Solenoids may be assembled as a complete unit. Tightening is accomplished by means of a hex flange at the base of the solenoid. The 3/4" bonnet construction (Figure 1) must be disassembled for installation and installed with a special wrench adapter.

Installation of Panel Mounted Solenoid (See Figure 3)

Disassemble solenoid following instruction under Solenoid Replacement then proceed

3/4" Valve Bonnet Construction

1. Install retainer(convex side to solenoid) in 1.312 diameter mounting hole in customer panel.
2. Then position spring washer over plugnut/core tube sub-assembly.
3. Install plugnut/core tube sub-assembly through retainer in customer panel. Then replace solenoid, nameplate/retainer and red cap.

15/16" Valve Bonnet Construction

1. Install solenoid base sub-assembly through 0.69 diameter mounting hole in customer panel.
2. Position spring washer on opposite side of panel over solenoid base sub-assembly then replace.

Solenoid Temperature

Standard solenoids are designed for continuous duty service. When the solenoid is energized for a long period, the solenoid becomes hot and can be touched by hand only for an instant. This is a safe operating temperature.

MAINTENANCE

WARNING: To prevent the possibility of personal injury or property damage, turn off electrical power, depressurize solenoid operator and/or valve, and vent fluid to a safe area before servicing.

Cleaning

All solenoid operators and valves should be cleaned periodically. The time between cleaning will vary depending on medium and service conditions. In general, if the voltage to the solenoid is correct, sluggish valve operation, excessive noise or leakage will indicate that cleaning is required. Clean strainer or filter when cleaning the valve,

Preventive Maintenance

- Keep the medium flowing through the solenoid operator or valve as free from dirt and foreign material as possible.
- While in service, the solenoid operator or valve should be operated at least once a month to insure proper opening and closing.
- Depending on the medium and service conditions, periodic inspection of internal valve parts for damage or excessive wear is recommended. Thoroughly clean all parts. Replace any worn or damaged parts.

Causes of Improper Operation

- **Faulty Control Circuit:** Check the electrical system by energizing the solenoid. A metallic click signifies that the solenoid is operating. Absence of the click indicates loss of power supply. Check for loose or blown fuses, open-circuited or grounded solenoid, broken lead wires or splice connections.

- **Burned-Out Solenoid:** Check for open-circuited solenoid. Replace if necessary. Check supply voltage; it must be the same as specified on nameplate/retainer and marked on the solenoid. Check ambient temperature and check that the core is not jammed.

- **Low Voltage:** Check voltage across the solenoid leads. Voltage must be at least 85% of rated voltage.

Solenoid Replacement

1. On solenoids with lead wires disconnect conduit, coil leads, and grounding wire.

NOTE: Any optional parts attached to the old solenoid must be reinstalled on the new solenoid.

2. Disassemble solenoids with optional features as follows:

• Spade or Screw Terminals

Remove terminal connections, grounding screw, grounding wire, and terminal block (screw terminal type only).

NOTE: For screw terminals, the socket head screw holding the terminal block serves as a grounding screw.

• Junction Box

Remove conduit and socket head screw (use 5/32" hex key wrench) from center of junction box. Disconnect junction box from solenoid.

• DIN Plug Connector

Remove center screw from DIN plug connector. Disconnect DIN plug connector from adapter. Remove socket head screw (use 5/32" hex key wrench), DIN terminal adapter, and gasket from solenoid.

3. Snap off red cap from top of solenoid base sub-assembly.
4. Push down on solenoid. Then using a suitable screwdriver, insert blade in slot provided between solenoid and nameplate/retainer. Pry up slightly and push to remove. Then remove solenoid from solenoid base sub-assembly.
5. Reassemble using exploded views for parts identification and placement

Disassembly and Reassembly of Solenoids

1. Remove solenoid, see Solenoid Replacement.
2. Remove finger washer or spring washer from solenoid base sub-assembly.
3. Unscrew solenoid base sub-assembly.

NOTE: Some solenoid constructions have a plugnut/core tube sub-assembly, bonnet gasket and bonnet in place of the solenoid base sub-assembly. To remove bonnet use special wrench adapter supplied in ASCO Rebuild Kit. For wrench adapter only, order ASCO Wrench Kit No.K218 - 948.

4. The core is now accessible for cleaning or replacement.
5. If the solenoid is part of a valve, refer to basic valve installation and maintenance instructions for further disassembly.
6. Reassemble using exploded views for identification and placement of parts.

ORDERING INFORMATION FOR ASCO SOLENOIDS

When Ordering Solenoids for ASCO Solenoid Operators or Valves, order the number stamped on the solenoid. Also specify voltage and frequency.

Torque Chart

Part Name	Torque Value in inch-Pounds	Torque Value in Newton-Meters
solenoid base sub-assembly	175 ± 25	19.8 ± 2.8
valve bonnet (3/4" bonnet constructions)	90 ± 10	10.2 ± 1.1
bonnet screw (3/8" or 1/2" NPT pipe size)	25	2.8
bonnet screw (3/4" NPT pipe size)	40	4.5

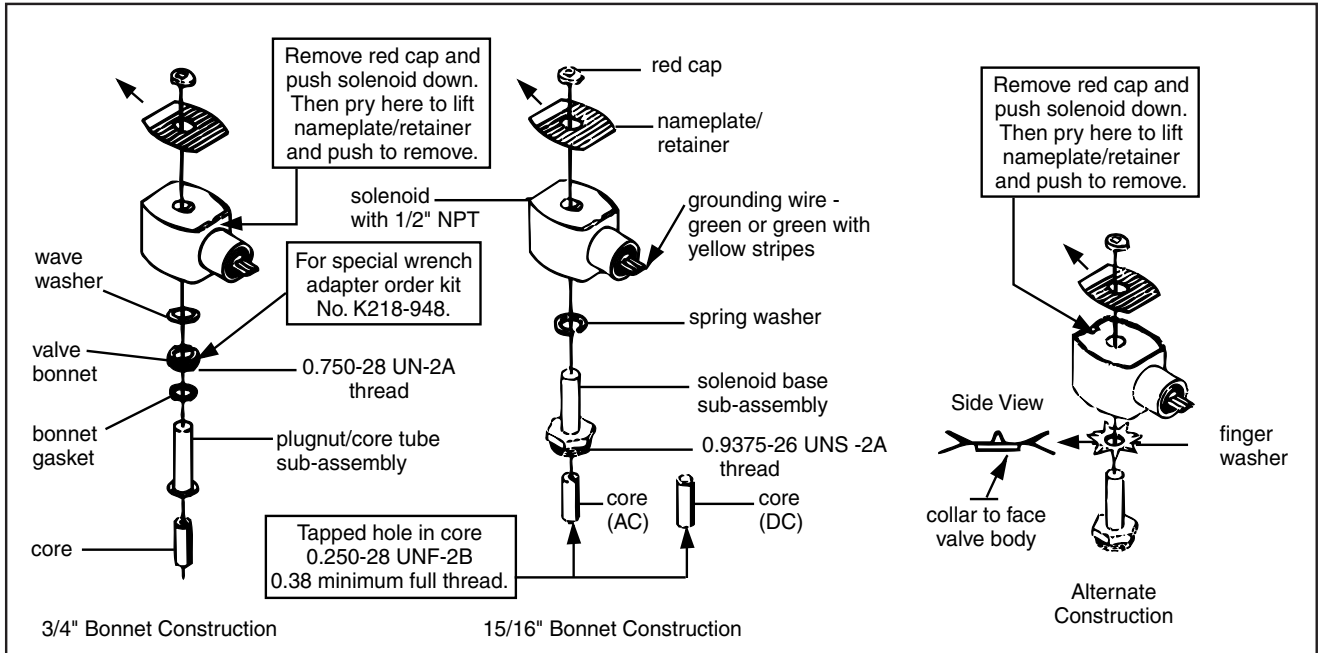

Figure 1. Series 8016G solenoids

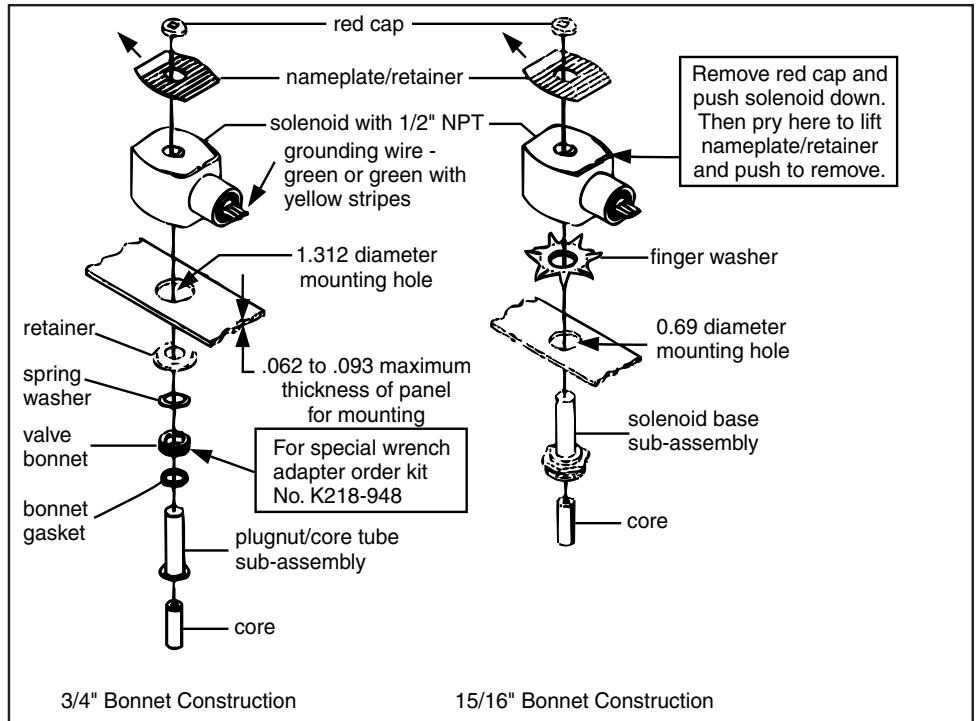
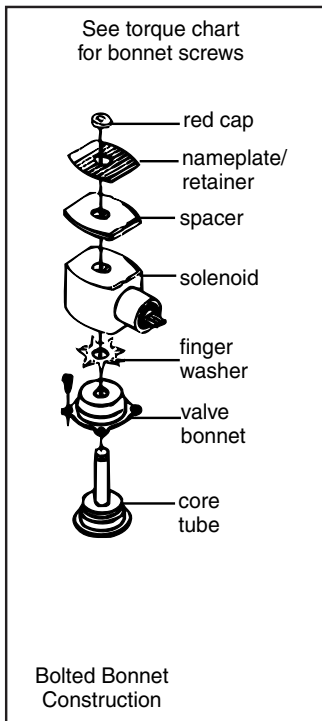

Figure 2. Series 8016G solenoid

Figure 3. Series 8016G panel mounted solenoids

Torque Chart

Part Name	Torque Value in inch-Pounds	Torque Value in Newton-Meters
terminal block screws	10 ± 2	1,1 ± 0,2
socket head screw	15 - 20	1,7 - 2,3
center screw	5 ± 1	0,6 ± 0,1

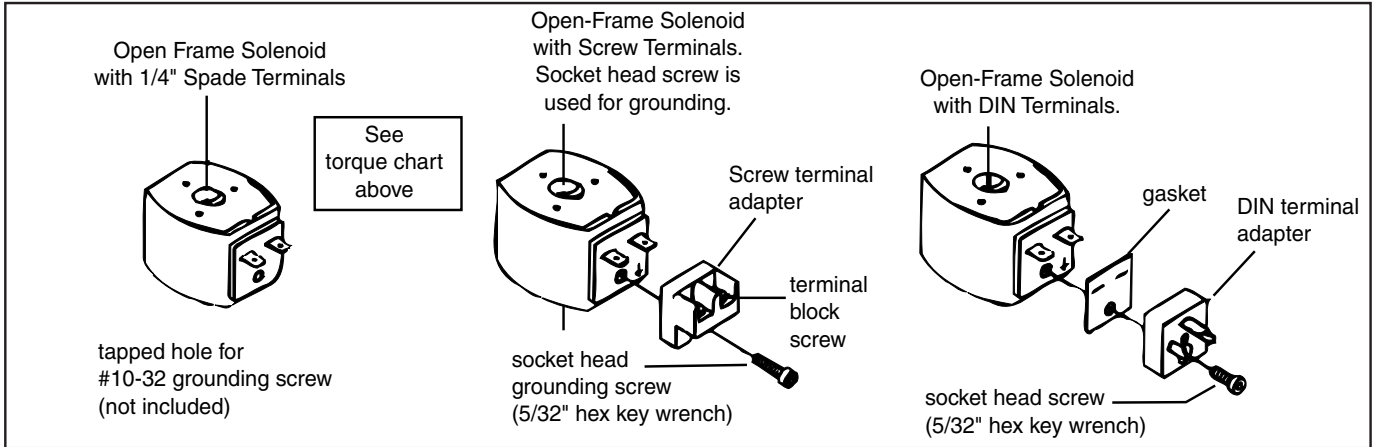

Figure 4. Open - frame solenoids

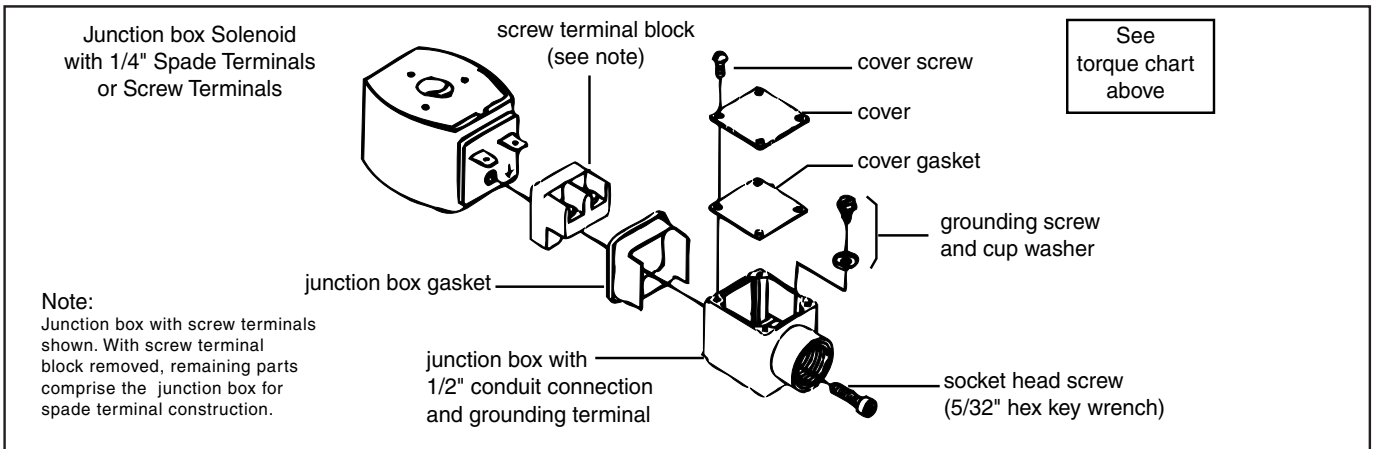
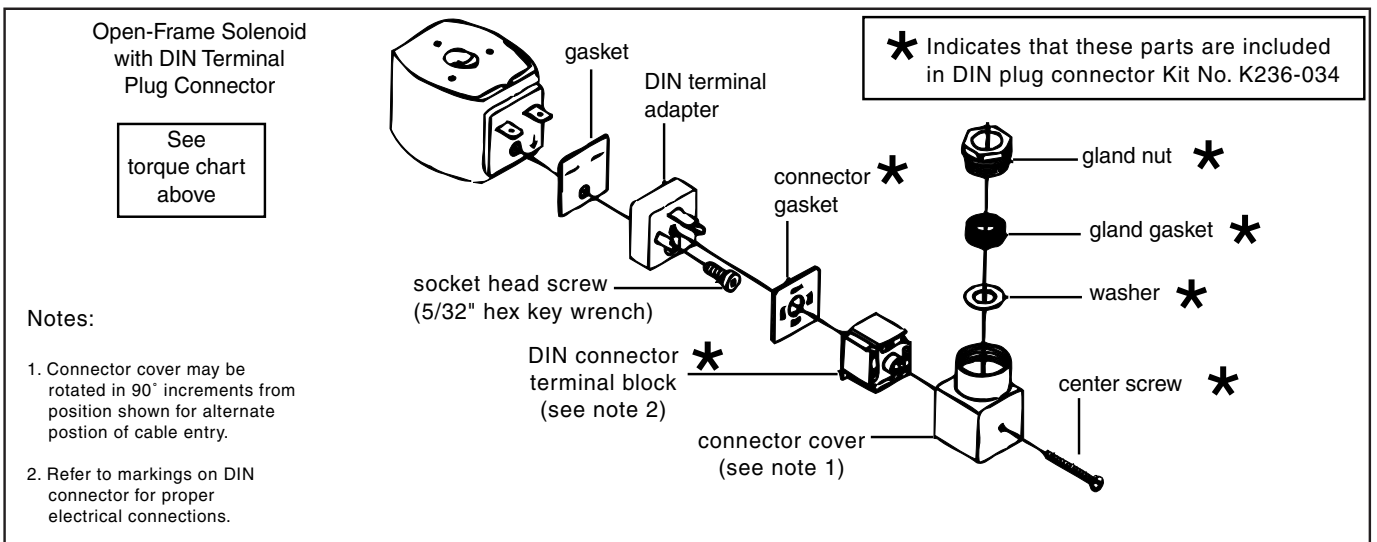

Figure 5. Open - frame solenoids



PARTS LIST

ITEM NO.	DESCRIPTION
1	SCREW, MACHINE, FIL. HD.
2	WASHER, LOCK
3	NAMEPLATE
4	COVER
5	SCREW, MACHINE, RD. HD.
6	WASHER, DIAPHRAGM
7	DIAPHRAGM
8	WASHER, DIAPHRAGM, SPRING RETAINING
9	SPRING
10	BODY, POWERTRON
11	"O" RING, BODY TO BODY
12	BODY
13	
14	
15	
16	
17	
18	STEM ASSEMBLY
19	SEAT, VALVE, UPPER
20	GASKET
21	SEAT, VALVE, LOWER
22	GASKET, STEM
23	PLUG, VENT. (USED ONLY WITH OPTIONAL FEATURE "G")
24	SEELSKREW (OMIT WITH OPTIONAL FEATURE "H")
25	"O" RING (OMIT WITH OPTIONAL FEATURE "H")
26	PLUG, PIPE (USED ONLY WITH OPTIONAL FEATURE "H")
27	O'RING, SEAT
28	PLUG, PIPE 1/8"

CLA-VAL CATALOG NUMBER	DESCRIPTION
102C-2	SPRING UNDER DIAPHRAGM BOTH ACTUATING CONNECTIONS OPEN
102C-3	SPRING OVER DIAPHRAGM BOTH ACTUATING CONNECTIONS OPEN

SUFFIX LETTER	DESCRIPTION
A	ORIFICE IN BRIDGEMALL
B	ORIFICE IN LOWER SEAT
G	VENT PLUG IN POWERTRON ACTUATING CONNECTION
H	PIPE PLUG IN POWERTRON ACTUATING CONNECTION

CATALOG NUMBER EXAMPLE:
 102C-2 B H

PIPE PLUG IN POWERTRON ACTUATING CONNECTION
 ORIFICE IN LOWER SEAT
 BASIC VALVE WITH SPRING UNDER THE DIAPHRAGM

LETTER	DESCRIPTION	DATE	BY	DATE	REVISION RECORD
E	DELETED ITEMS 13, 14, 15, 16 AND 17 IN ORDER TO MAKE ROOM FOR STEAM ASSEMBLY (SEE PARTS LIST)	11/16/66	SAV	11/17/66	66859
D	ADD ITEM NO. 27	11/17/66	SAV	11/17/66	66859
C	ADD ITEM NO. 21	11/17/66	SAV	11/17/66	66859
B	ADD ITEM NO. 27	11/17/66	SAV	11/17/66	66859
A	REPLACED NAMEPLATE	11/17/66	SAV	11/17/66	66859

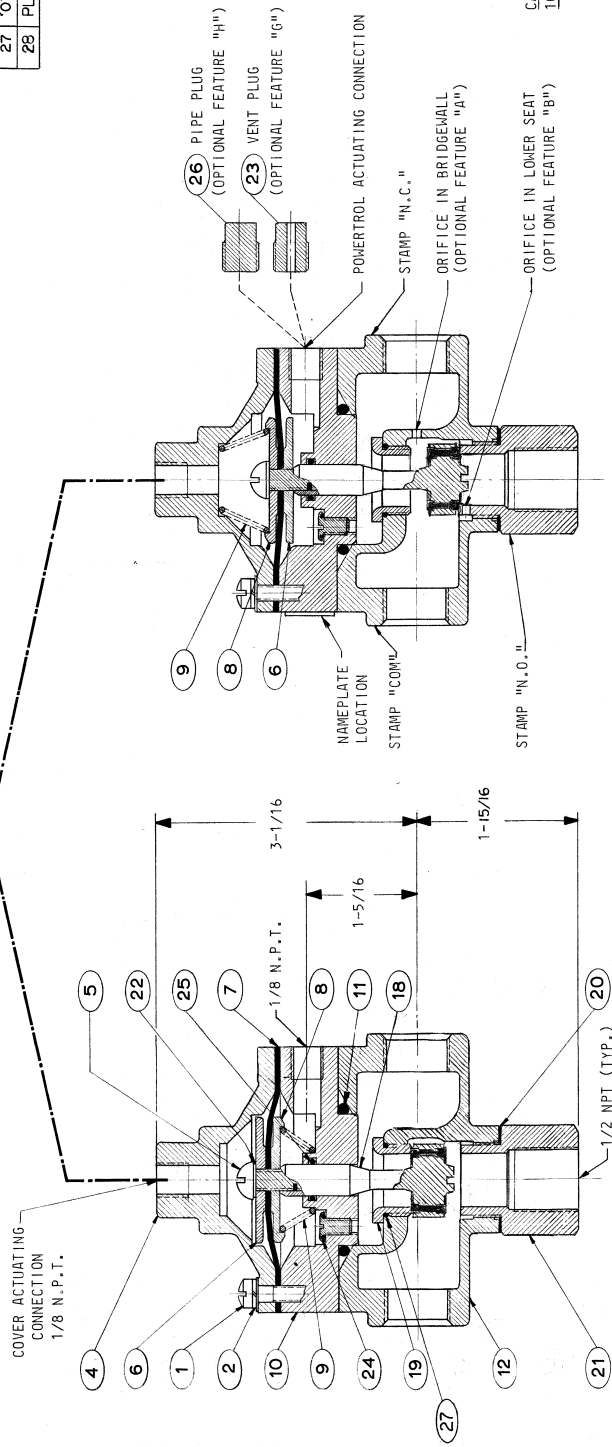
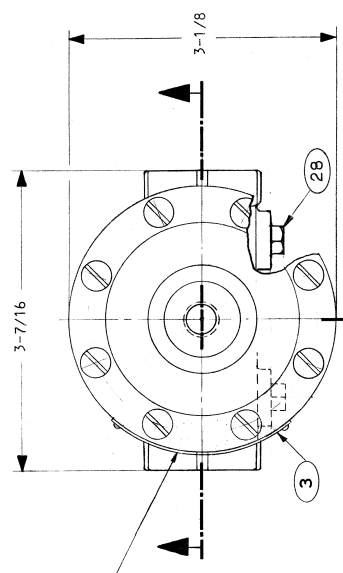

102C-2 SERIES
 (WITH SPRING UNDER DIAPHRAGM)

102C-3 SERIES
 (WITH SPRING OVER DIAPHRAGM)

DR.	CHK.	APP'D.	SCALE	DATE	REVISION RECORD
SAV	SAV	SAV		11/16/66	66859
				11/17/66	66859
				11/17/66	66859

CLA-VAL CO. NEWPORT BEACH, CALIFORNIA, U.S.A.

DESCRIPTION: 1/2" NO. 102C SERIES THREE-WAY VALVE SINGLE DIAPHRAGM - POWERTRON TYPE SCREENED ENDS

CODE NUMBER: **86184**



D 0074

Flow Control

Model CVS-1



- No Lubrication
- Corrosion Resistant
- One Moving Part
- Replaceable Teflon Coated Seal
- Fast Acting, Non-Sticking
- Easy Maintenance

The CVS-1 Shuttle Valve is precision engineered for lasting dependable service. The CVS-1 combines instantaneous action with one moving part designed for smooth positive operation with minimum wear. The flow pattern interconnects the highest pressure from two separate pressure zones (ports "A" or "B") to a common port "C". The two pressure zones, ports A or B can never flow to one another.

The design incorporates precision sealing required for low pressure or high pressure operation. The seal is teflon coated to prevent sticking under the most adverse conditions of exposure or prolonged actuation in one position. The CVS-1 Shuttle Valve incorporates all the required features for lasting dependable service.

Specifications

Size	3/8"
End Detail	3/8" NPT — Three Female Connections
Pressure Rating	400 psi Max.
Shifting Differential	10" Water Column Differential
CV Factor	"A" to "C" 3.5 "B" to "C" 3.1
Temperature Range	Water to 140°F
Materials	Body Cast Bronze ASTM B-62 Internal Trim Delrin Rubber Parts Static Seal Buna-N® Synthetic Rubber Shuttle Seal Buna-N® Synthetic Rubber Teflon Coated

Dimensions

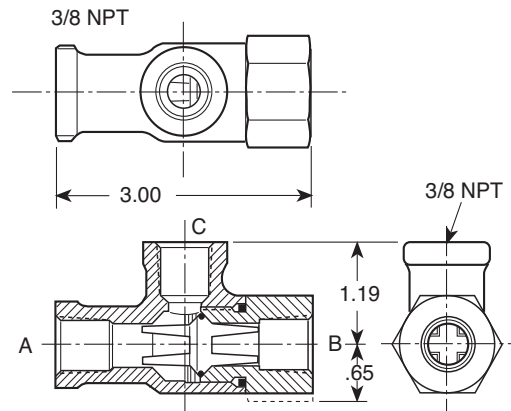

Principle of Operation

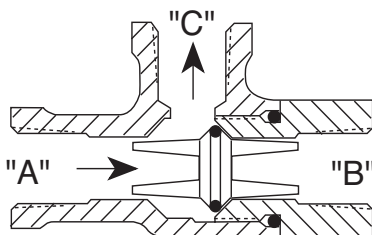

Flow Direction "A" to "C"

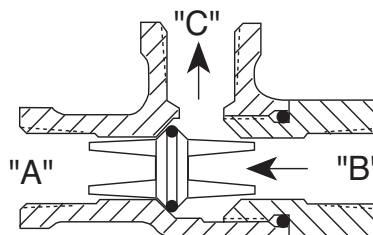

Flow Direction "B" to "C"

When Ordering, Please Specify

1. Catalog Number
2. Minimum-maximum line pressure
3. Fluid to be handled
4. Temperature
5. Materials



— MODELS — **X105L**
X105L2

Limit Switch Assemblies



- **UL Listed Switches**
- **Positive Action**
- **Rugged and Dependable**
- **Weather Proof or Explosion Proof**
- **Easy To Adjust**

The Cla-Val Model X105L/X105L2 Limit Switch Assembly is a rugged, dependable and positive acting switch assembly actuated by the opening or closing of a Cla-Val control valve on which it is mounted. The single pole, double throw micro switch can be connected either to open or to close an electrical circuit when actuated. By loosening the allen screw on the actuating collar and raising or lowering the collar on the stem, the X105L is easily adjusted to signal that the valve has fully reached the desired position (open or closed).

Installation

Single Pole Double Throw Switch

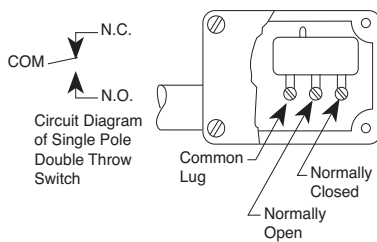

Double Pole Double Throw Switch

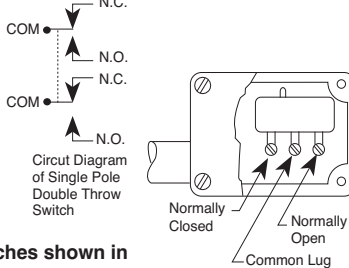

Switches shown in unactivated position.

1. Remove plug in top of valve cover.
2. Screw actuating stem into main valve stem.
3. Slip adapter down over stem and screw into place on valve cover.
4. Attach micro switch housing and bracket to adapter with jam nut.
5. Bring electrical supply circuit into unit through the 1/2" tapping in micro switch housing.
6. Adjust switch collars. (Set collar to trip switch after valve is positioned fully open or fully closed)

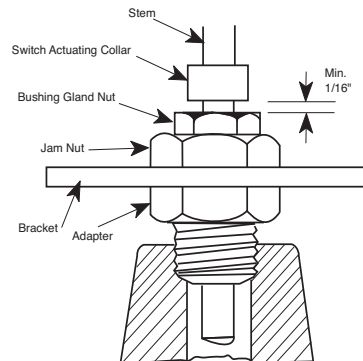

Actuating Collar Adjustment Minimum Setting

When adjusting actuating collar for proper switch action, a clearance of at least 1/16" (1/8" for 48" valve) must be provided between the collar and the bushing gland nut when valve is in the fully closed position.

Purchase Specifications

The assembly shall be bracket-mounted to exterior of an adapter attached to the center of the main valve cover. A stainless steel actuating stem with a swivel adapter shall be fastened directly to the main valve stem and move vertically through an adapter and gland with two O-ring seals as the valve moves. An adjustable collar located on the actuating stem shall actuate the sensor arm of a switch when valve has fully reached the open or closed (specify) position. The rotary-type position sensor arm shall actuate SPDT or DPDT type (specify) micro-switches mounted inside protective housing either weather-tight or explosion-proof NEMA rated (specify).

Provisions shall be made for bleeding air from valve cover through a small bleed screw and washer located on one wrench flat of adapter. All assemblies shall be capable of accommodating up to three switches. Standard materials in contact with operating fluid are brass, stainless steel, Monel and Buna-N.

A conduit hub opening in the switch enclosure shall be provided for attaching protective weatherproof conduit for the electrical switch wires (wiring and conduit supplied by others). A sealing plug shall be provided to protect conduit opening during shipping or storage.

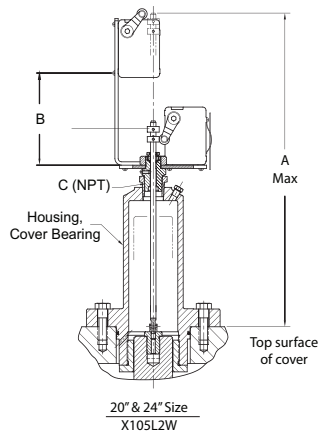
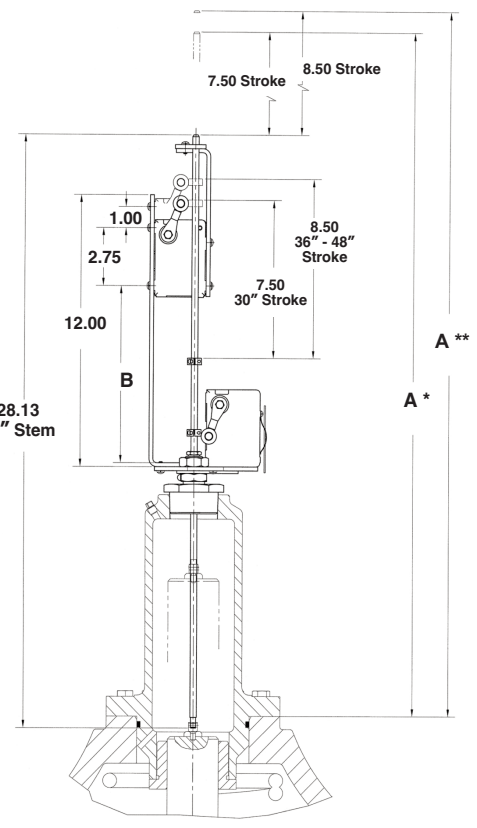
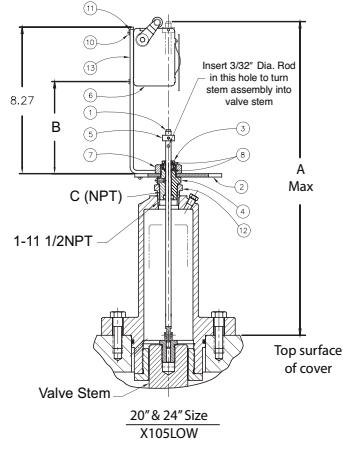
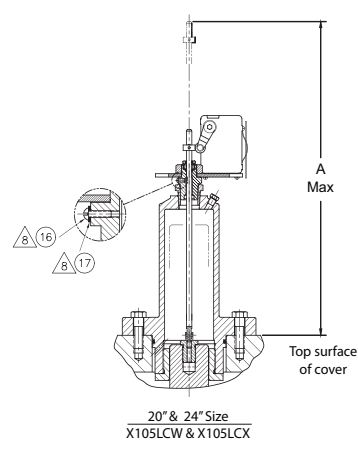
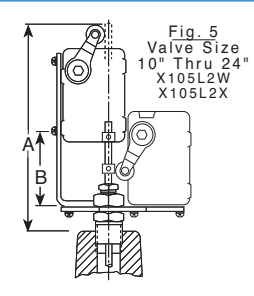
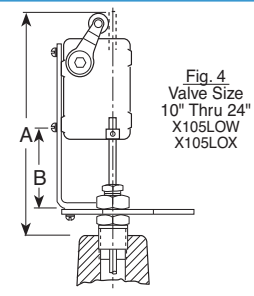
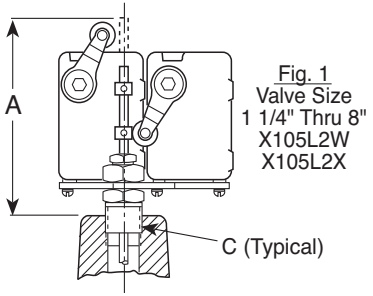
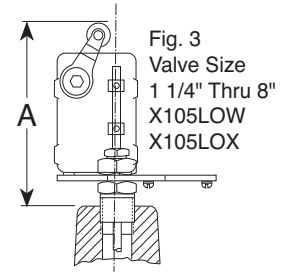
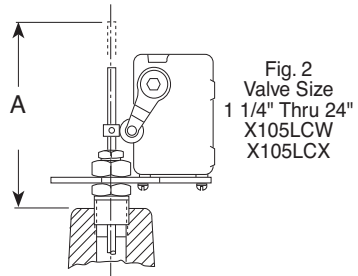
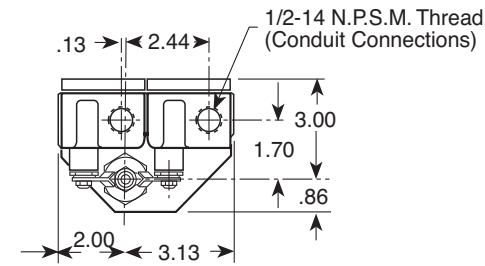

X105 Series Dimensions (In Inches)

A* - 30" • A** - 36", 42" & 48" Size

BasicValve 100-01	1 1/4	1 1/2	2	2 1/2	3	4	6	8	10	12	14	16	18	20	24	30	36*	42*	48*
Dimension "A"	10.19	10.19	7.16	7.16	7.34	7.00	6.69	6.91	9.88	9.59	9.16	10.78	10.78	18.23	19.10	35.07	36.07	36.07	36.07
Dimension "B"							1.69	1.69	2.44	2.94	2.94	2.94	2.94	4.32	5.19	8.40	8.40	8.40	8.40
C (NPT)	1/4	1/4	1/2	1/2	1/2	3/4	3/4	1	1	1 1/4	1 1/2	2	2	3/4	3/4	2	2	2	2
BasicValve 100-20					3	4	6	8	10	12	14	16	18	20	24	30	36*	42*	48*
Dimension "A"					7.16	7.34	7.00	6.69	6.91	9.88	9.59	9.59	10.78	10.78	10.78	11.30	35.07	36.07	36.07
Dimension "B"								1.69	1.69	2.44	2.94	2.94	2.94	2.94	2.94	5.19	8.40	8.40	8.40
C (NPT)					1/2	1/2	3/4	3/4	1	1	1 1/4	1 1/4	2	2	2	1	2	2	2



X105L

Limit Switch Assembly

Parts list shown is for sizes 16" and smaller.
Please consult factory for parts on sizes 18",
20", 24", 30", 36", 42" and 48".

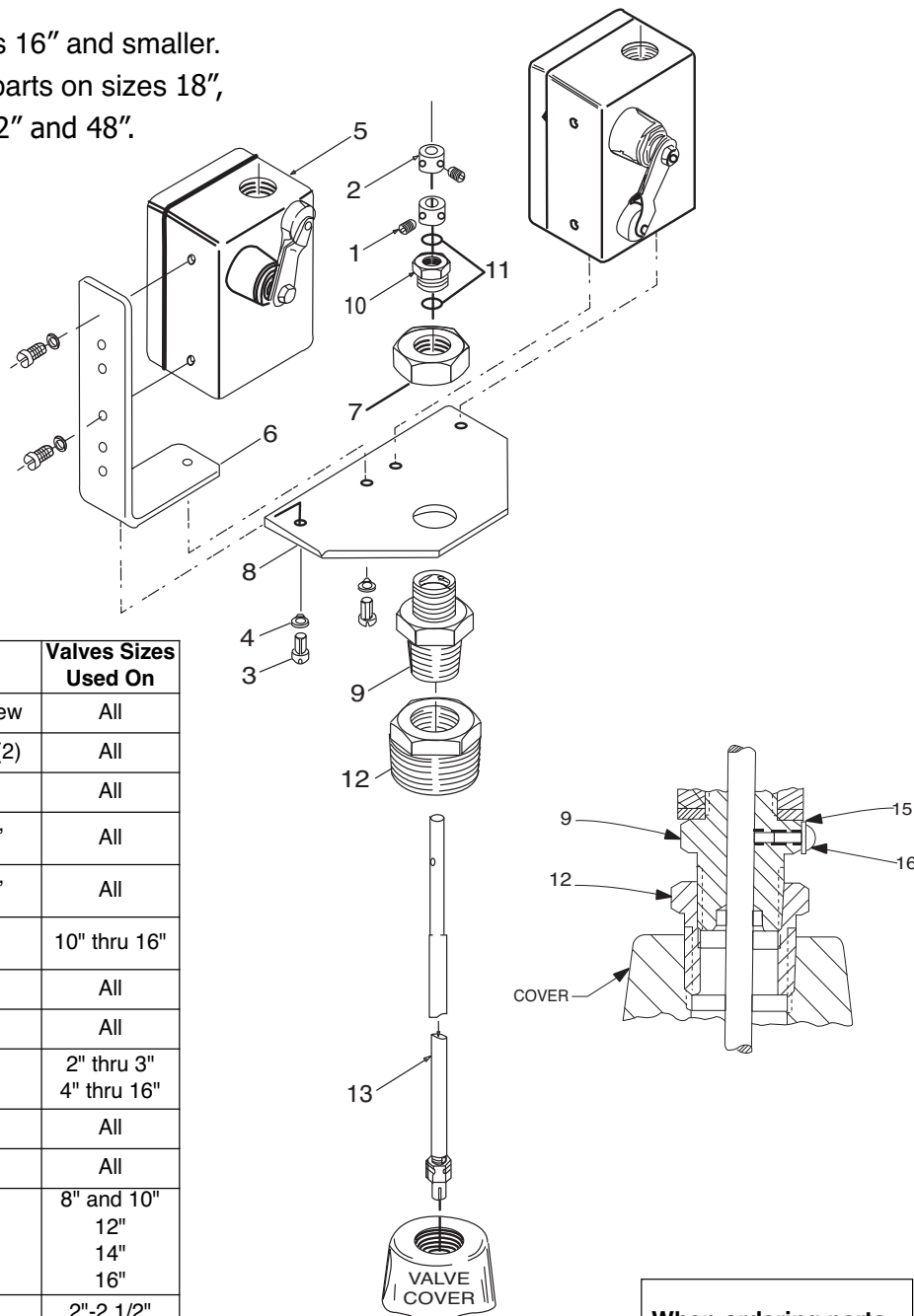

Item	Part Number	Description	Valves Sizes Used On
1-2	20441701E	Collar W/Set Screw	All
3	67578-21B	Screw, Machine (2)	All
4	67584-23F	Washer, Lock (2)	All
5	34637K	Switch Assembly, Weather Proof	All
	34633J	Switch Assembly, Explosion Proof	All
6	64310G	Bracket Switch Mounting	10" thru 16"
7	67815-06J	Nut, Jam	All
8	63674G	Plate, Mounting	All
9	2838201J 2838202G	Adapter Adapter	2" thru 3" 4" thru 16"
10	63398C	Bushing, Gland	All
11	00951E	O-Ring (2)	All
12	6764417K 6764418H 6764419F 6764491J	Bushing Bushing Bushing Bell Reducer	8" and 10" 12" 14" 16"
13	8970101F 8970102D 8970103B 8970104K 8970105G	Stem, Actuating Stem, Actuating Stem, Actuating Stem, Actuating Stem, Actuating	2"-2 1/2" 3"-4" 6"-8" 10"-12"-14" 16"
15	6551201H	Fiber Washer	All
16	6824421K	Screw 8-32 x 3/8	All

When ordering parts, please specify:

- Item Number
- Description
- Part Number

Typical Applications

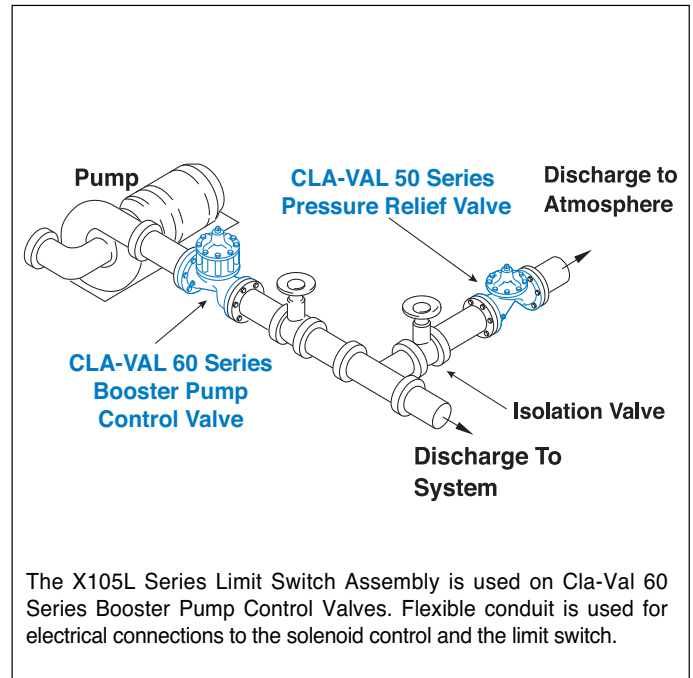
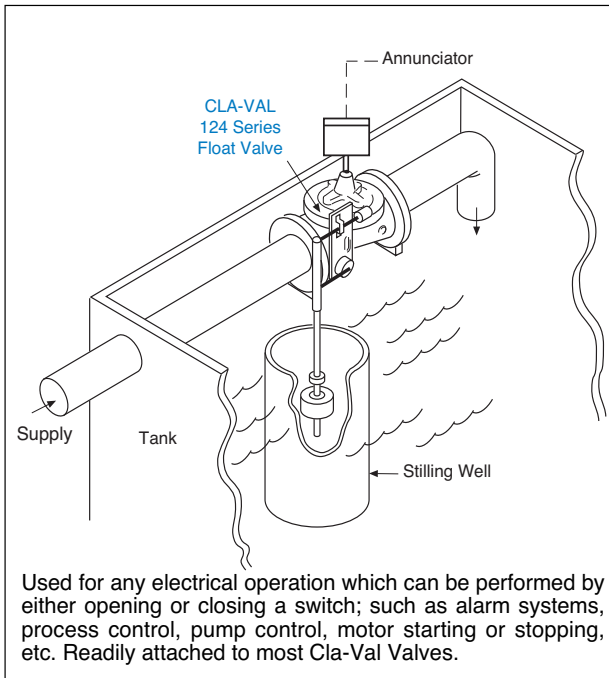

Specifications

Materials: Aluminum switch housing
Steel bracket and brass adapter
Stainless steel stem

Electrical: 1/2" Conduit connection

Switch Type: SPDT UL, File No. E12252,
CSA Certified, File No. LR57325
Weather proof
NEMA 1,3,4, and 13

Switch Rating: UL/CSA rating: L96
15 amp. 125, 250, or 480 volts AC
1/2 amp. 125 volts DC
1/4 amp. 250 volts DC

Switch Options: DPDT switches available on request
UL/CSA Rating: L59, 10 amps

Explosion proof micro switches are
NEMA 1,7, and 9
UL Listed, File No. E14274 and CSA
Certified, File No. LR57324: Class I,
Group C and D and Class II, Group
E, F and G.

When Ordering, Please Specify

1. Valve Size and Basic Valve Model Number
2. Catalog Number from Table Below
3. All Valve Name Plate Data
4. Select Single or Double Pole Switch
5. Explosion Proof or Weather Proof Type Enclosure
6. Amperes and Voltage, AC or DC
7. Actuating Position (Valve Open or Closed)

CATALOG NO.	ACTUATION POSITION	SWITCH ENCLOSURE
X105LCW	Valve Closed	Weather Proof
X105LCX	Valve Closed	Explosion Proof
X105LOW	Valve Open	Weather Proof
X105LOX	Valve Open	Explosion Proof
X105L2W	Dual	Weather Proof
X105L2X	Dual	Explosion Proof



E-X105L/X105L2 (R-11/2015)

CLA-VAL

1701 Placentia Ave. Costa Mesa, CA 92627-4475
Phone: 949-722-4800 • Fax: 949-548-5441

CLA-VAL CANADA

4687 Christie Drive
Beamsville, Ontario
Canada L0R 1B4
Phone: 905-563-4963
Fax: 905-563-4040

CLA-VAL EUROPE

Chemin des Mesanges 1
CH-1032 Romanel/
Lausanne, Switzerland
Phone: 41-21-643-15-55
Fax: 41-21-643-15-50

©COPYRIGHT CLA-VAL 2015 Printed in USA
Specifications subject to change without notice.

www.cla-val.com

Represented By:

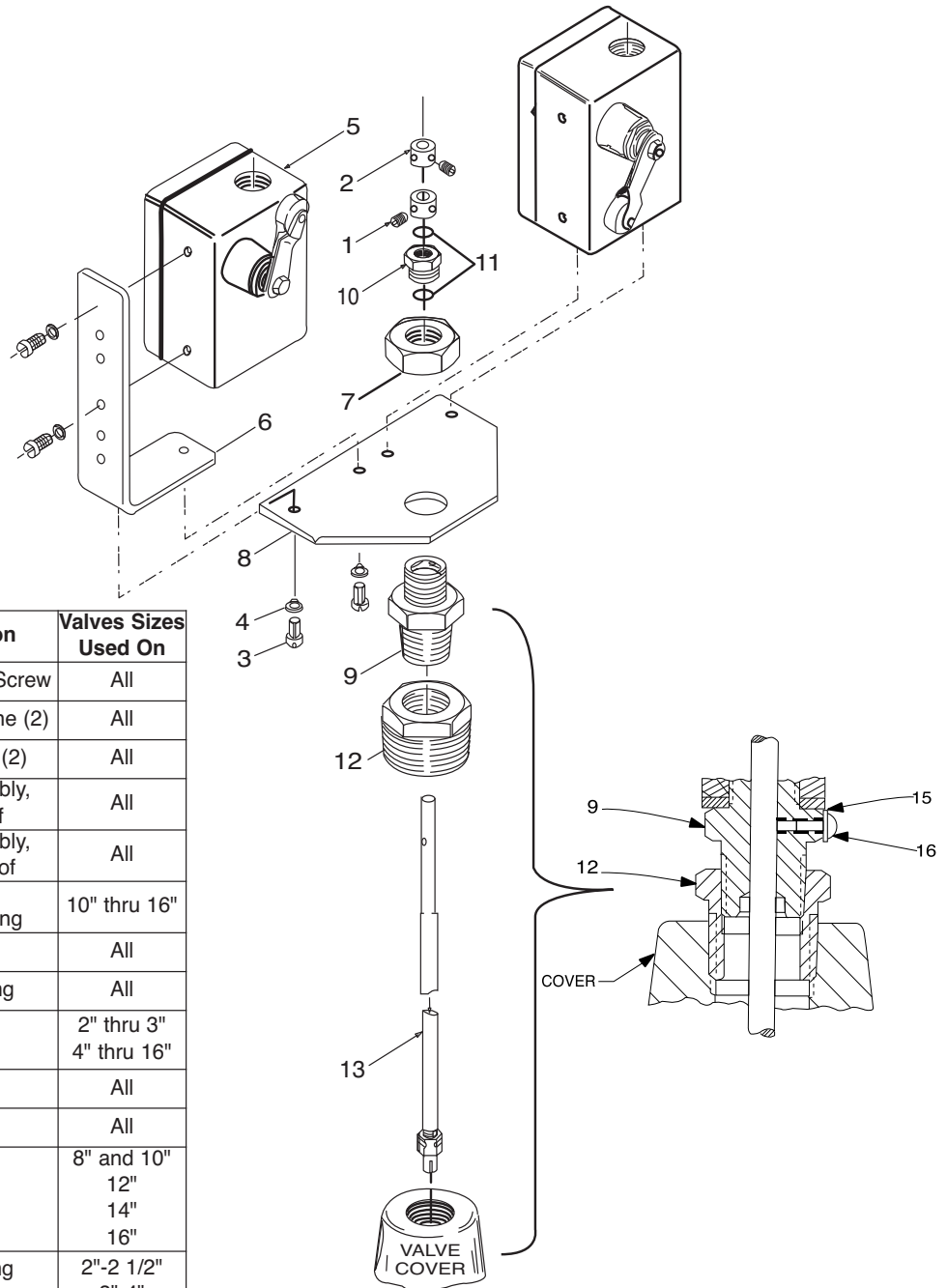
X105L**Limit Switch Assembly**

Item	Part Number	Description	Valves Sizes Used On
1-2	20441701E	Collar W/Set Screw	All
3	67578-21B	Screw, Machine (2)	All
4	67584-23F	Washer, Lock (2)	All
5	34637K	Switch Assembly, Weather Proof	All
	34633J	Switch Assembly, Explosion Proof	All
6	64310G	Bracket Switch Mounting	10" thru 16"
7	67815-06J	Nut, Jam	All
8	63674G	Plate, Mounting	All
9	2838201J	Adapter	2" thru 3"
	2838202G	Adapter	4" thru 16"
10	63398C	Bushing, Gland	All
11	00951E	O-Ring (2)	All
12	67644-17K	Bushing	8" and 10"
	67644-18H	Bushing	12"
	67644-19F	Bushing	14"
	67644-91J	Bell Reducer	16"
13	89701-01F	Stem, Actuating	2"-2 1/2"
	89701-02D	Stem, Actuating	3"-4"
	89701-03B	Stem, Actuating	6"-8"
	89701-04K	Stem, Actuating	10"-12"-14"
	89701-05G	Stem, Actuating	16"
15	6551201H	Fiber Washer	All
16	6824421K	Screw 8-32 x 3/8	All

When ordering parts, please specify:

- Item Number
- Description
- Part Number



—MODEL— **CV**
Flow Control

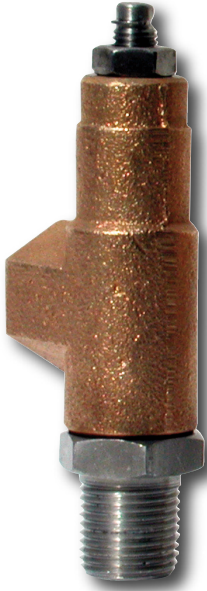

DESCRIPTION

The CV Control is an adjustable restriction which acts as a needle valve when flow is in the direction of the stem. When flow is in the reverse direction, the port area opens fully to allow unrestricted flow. When installed in the control system of a Cla-Val automatic valve, it can be arranged to function as either an opening or closing speed control.

OPERATION

The CV Flow Control permits full flow from port A to B, and restricted flow in the reverse direction. Flow from port A to B lifts the disc from seat, permitting full flow. Flow in the reverse direction seats the disc, causing fluid to pass through the clearance between the stem and the disc. This clearance can be increased, thereby increasing the restricted flow, by screwing the stem out, or counter-clockwise. Turning the stem in, or clockwise reduces the clearance between the stem and the disc, thereby reducing the restricted flow.'

INSTALLATION

Install the CV Flow Control as shown in the valve schematic. All connections must be tight to prevent leakage.

DISASSEMBLY

Follow the sequence of the item numbers assigned to the parts in the cross sectional illustration for recommended order of disassembly.

Use a scriber, or similar sharp-pointed tool to remove O-ring from the stem.

INSPECTION

Inspect all threads for damage or evidence of cross-threading. Check mating surface of seat and valve disc for excessive scoring or embedded foreign particles. Check spring for visible distortion, cracks and breaks. Inspect all parts for damage, corrosion and cleanliness.

CLEANING

After disassembly and inspection, cleaning of the parts can begin. Water service usually will produce mineral or lime deposits on metal parts in contact with water. These deposits can be cleaned by dipping the parts in a 5-percent muriatic acid solution just long enough for deposits to dissolve. This will remove most of the common types of deposits. **Caution: use extreme care when handling acid.** If the deposit is not removed by acid, then a fine grit (400) wet or dry sandpaper can be used with water. Rinse parts in water before handling. An appropriate solvent can clean parts used in fueling service. Dry with compressed air or a clean, lint-free cloth. Protect from damage and dust until reassembled.

REPAIR AND REPLACEMENT

Minor nicks and scratches may be polished out using a fine grade of emery or crocus cloth; replace parts if scratches cannot be removed.

Replace O-ring packing and gasket each time CV Flow Control is overhauled.

Replace all parts which are defective. Replace any parts which create the slightest doubt that they will not afford completely satisfactory operation. Use Inspection steps as a guide.

REASSEMBLY

Reassembly is the reverse of disassembly; no special tools are required.

TEST PROCEDURE

No testing of the flow Control is required prior to reassembly to the pilot control system on Cla-Val Main Valve.



CV

3/8" Flow Control

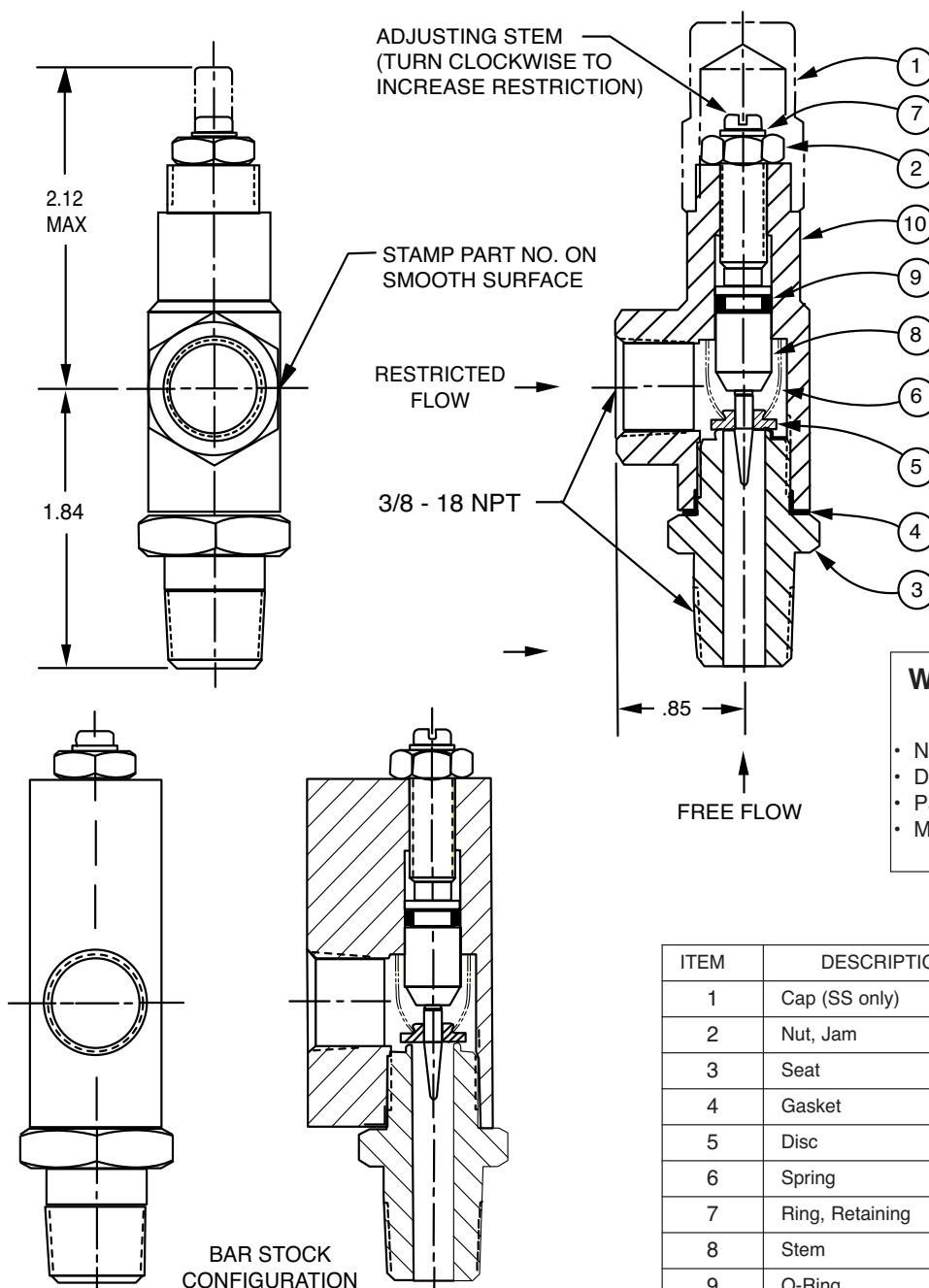
**When ordering parts,
please specify:**

- Number Stamped on Side
- Description (CV Flow Control)
- Part Description
- Material

ITEM	DESCRIPTION	QTY
1	Cap (SS only)	1
2	Nut, Jam	1
3	Seat	1
4	Gasket	1
5	Disc	1
6	Spring	1
7	Ring, Retaining	1
8	Stem	1
9	O-Ring	1
10	Housing	1



— MODEL — **X46**

Flow Clean Strainer



X46A Straight

- Self Scrubbing Cleaning Action
- Straight Type or Angle Type

The Cla-Val Model X46 Strainer is designed to prevent passage of foreign particles larger than .015". It is especially effective against such contaminant as algae, mud, scale, wood pulp, moss, and root fibers. There is a model for every Cla-Val. valve.

X46B Angle

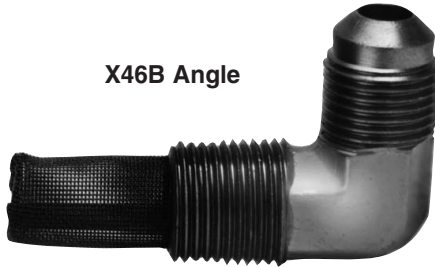

The X46 Flow Clean strainer operates on a velocity principle utilizing the circular "air foil" section to make it self cleaning. Impingement of particles is on the "leading edge" only. The low pressure area on the downstream side of the screen prevents foreign particles from clogging the screen. There is also a scouring action, due to eddy currents, which keeps most of the screen area clean.

Dimensions (In Inches)

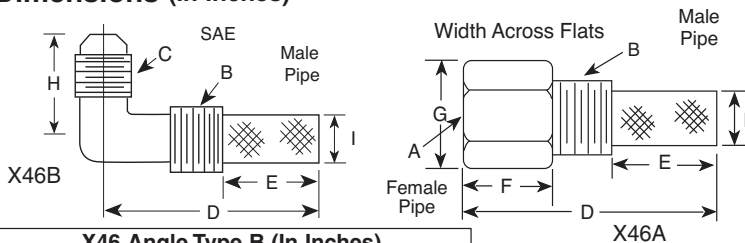

B(NPT)	C(SAE)	D	E	H	I
1/8	1/4	1-3/8	5/8	7/8	1/4
1/4	1/4	1-3/4	3/4	1	3/8
3/8	1/4	2	7/8	1	1/2
3/8	3/8	1-7/8	7/8	1	1/2
1/2	3/8	2-3/8	1	1-1/4	5/8

A (NPT)	B (NPT)	D	E	F	G	I
1/8	1/8	1-3/4	3/4	1/2	1/2	1/4
1/4	1/4	2-1/4	1	3/4	3/4	3/8
3/8	3/8	2-1/2	1	7/8	7/8	1/2
3/8	1/2	2-1/2	1-1/4	1/2	7/8	3/4
1/2	1/2	3	1-1/4	1	1-1/8	3/4
3/8	3/4	3-3/8	2	1/2	1	7/8
3/4	3/4	4	2	1	1-1/2	7/8
3/8	1	4-1/4	2-3/4	1/2	1-3/8	7/8
1	1	4-1/2	2-3/4	1-1/4	1-3/4	7/8
1/2	1	4-1/4	2-3/4	1/2	1-3/8	7/8

When Ordering, Please Specify:

- Catalog Number X46
- Straight Type or Angle Type
- Size Inserted Into and Size Connection
- Materials

INSTALLATION

The strainer is designed for use in conjunction with a Cla-Val Main Valve, but can be installed in any piping system where there is a moving fluid stream to keep it clean. When it is used with the Cla-Val Valve, it is threaded into the upstream body port provided for it on the side of the valve. It projects through the side of the Main Valve into the flow stream. All liquid shunted to the pilot control system and to the cover chamber of the Main Valve passes through the X46 Flow Clean Strainer.

INSPECTION

Inspect internal and external threads for damage or evidence of cross-threading. Check inner and outer screens for clogging, embedded foreign particles, breaks, cracks, corrosion, fatigue, and other signs of damage.

DISASSEMBLY

Do not attempt to remove the screens from the strainer housing.

CLEANING

After inspection, cleaning of the X46 can begin. Water service usually will produce mineral or lime deposits on metal parts in contact with water. These deposits can be cleaned by dipping X46 in a 5-percent muriatic acid solution just long enough for deposit to dissolve. This will remove most of the common types of deposits.

Caution: use extreme care when handling acid. If the deposit is not removed by acid, then a fine grit (400) wet or dry sandpaper can be used with water. Rinse parts in water before handling. An appropriate solvent can clean parts used in fueling service. Dry with compressed air or a clean, lint-free cloth. Protect from damage and dust until reassembled.

REPLACEMENT

If there is any sign of damage, or if there is the slightest doubt that the Model X46 Flow Clean Strainer may not afford completely satisfactory operation, replace it. Use Inspection steps as a guide. Neither inner screen, outer screen, nor housing is furnished as a replacement part. Replace Model X46 Flow Clean Strainer as a complete unit.

When ordering replacement Flow-Clean Strainers, it is important to determine pipe size of the tapped hole into which the strainer will be inserted (refer to column A or F), and the size of the external connection (refer to column B or G).

AK	07-10-08	BB	ADDED PN'S 67783-62B (NED 62200)
AK	08-14-08	BC	ADDED PN'S 67783-63K (NED 62218)
PC	10-1-2008	BD	ADDED PN 67783-64H (NED 62446)
CAD REVISION RECORD - DO NOT REVISE MANUALLY		BY	DATE
LTR	DESCRIPTION		
A-AY	SEE REVISION FILE		
BA	ADDED PN'S 67783-59H, 67783-60F & 67783-61D (ECO 20434)	AK	03-14-06

 CLA-VAL CO. NEWPORT BEACH, CALIFORNIA	CATALOG NO.	DRAWING NO.	REV
		67783	BD
TYPE OF VALVE AND MAIN FEATURES		DESIGN	
<p style="text-align: center; font-size: 24pt;">CK2 COCK/BALL VALVE</p>		DRAWN	MGR 4-02-80
		CHK'D	KD 4-03-80
		APV'D	CH 4-07-80

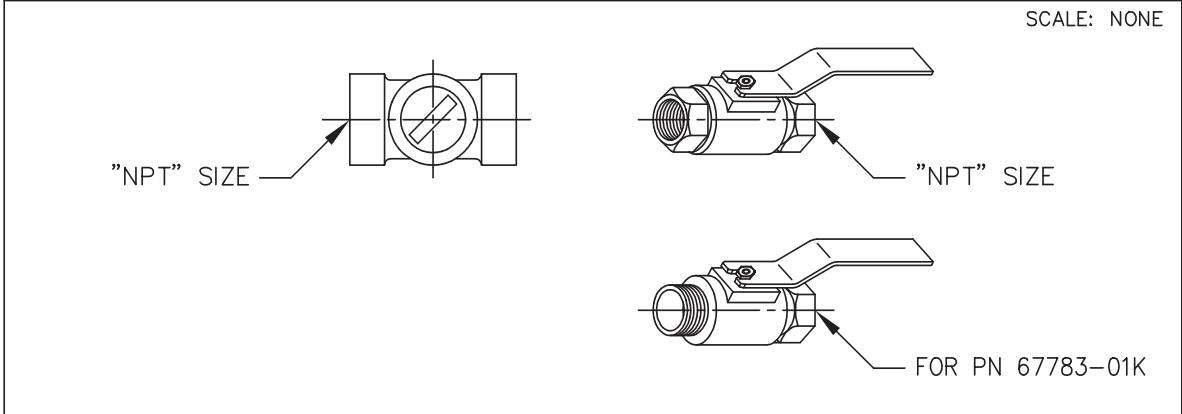

CLA-VAL PART NO. AND MATERIAL								
BRONZE WITH HANDLE	STEEL WITH HANDLE	IRON WITH HANDLE	316 SST WITH HANDLE	316 SST W/ LOCKING HANDLE	BRONZE WITH HANDLE	MONEL WITH HANDLE	MONEL W/ LOCKING HANDLE	SIZE "NPT"
67783-01K*	-09C	-17F	-25J SUPSD BY-26G		-41F SUPSD BY-01K			1/8"
-02H	-10A	-18D	-26G	-51E SUPSD BY-26G -52C	-42D SUPSD BY-02H	-55F		1/4"
-03F * -59H***	-11J	-19B	-27E	-46E SUPSD BY-27E -53A	-45G -57B * *	-48A SUPSD BY-49J	-63K	3/8"
-04D -60F ***	-12G	-20K	-28C	-54J	-43B SUPSD BY-04D	-49J	-62B	1/2"
-05A -61D ***	-13E	-21H	-29A	-64H	-44K SUPSD BY-05A	-56D		3/4"
-06J	-14C	-22F	-30J			-58K		1"
-07G	-15K	-23D	-31G					1 1/4"
-08E	-16H	-24B	-32E					1 1/2"
-50G			-47C					2"

- * SEE ENGINEERING APPROVED VENDORS TABLE (SHEET 2 OF 2).
- ** HAMMOND VALVE 8501 ONLY.
- *** WILKINS CK2 (SEE SHEET 2 OF 2)

"THIS DRAWING IS THE PROPERTY OF CLA-VAL CO. AND SAME AND COPIES MADE THEREOF, IF ANY, SHALL BE RETURNED TO IT UPON DEMAND. DELIVERY AND DISCLOSURE HEREOF ARE SOLELY UPON CONDITION THAT THE SAME SHALL NOT BE USED, COPIED OR REPRODUCED, NOR SHALL THE SUBJECT HEREOF BE DISCLOSED IN ANY MANNER TO ANYONE FOR ANY PURPOSE, EXCEPT AS HEREIN AUTHORIZED, WITHOUT PRIOR WRITTEN APPROVAL OF CLA-VAL CO. THIS DRAWING IS SUBMITTED CONFIDENTIALLY AND MAY NOT BE USED IN THE MANUFACTURE OF ANY MATERIAL OR PRODUCT OTHER THAN SUCH MATERIALS AND PRODUCTS FURNISHED TO CLA-VAL CO. WHETHER OR NOT THE EQUIPMENT OR INFORMATION SHOWN HEREON IS PATENTED OR OTHERWISE PROTECTED, FULL TITLE AND COPYRIGHTS, IF ANY, IN AND TO THIS DRAWING AND/OR INFORMATION DELIVERED OR SUBMITTED ARE FULLY RESERVED CLA-VAL CO."



X43 Strainer

ITEM	DESCRIPTION	MATERIAL
1	Pipe Plug	Steel
2	Strainer Plug	Brass
3	Gasket	Copper
4	Screen	SST
5	Body	Brass

No parts available. Replacement assembly only.

Standard 60 mesh pilot system strainer for fluid service.

Size	Stock Number
3/8 x 3/8	33450J

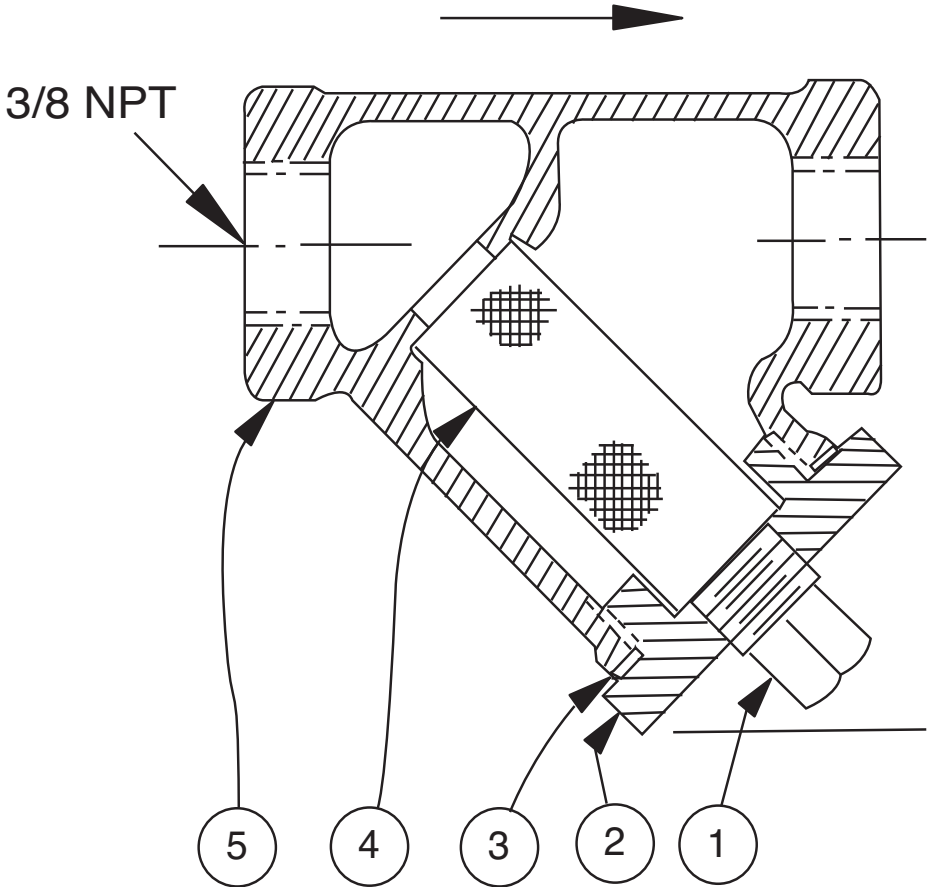

Proper Identification

For ordering repair kits, replacement parts, or for inquiries concerning valve operation, it is important to properly identify Cla-Val products already in service by including all nameplate data with your inquiry. Pertinent product data includes valve function, size, material, pressure rating, end details, type of pilot controls used and control adjustment ranges.

Identification Plates

For product identification, cast-in body markings are supplemented by identification plates as illustrated on this page. The plates, depending on type and size of product, are mounted in the most practical position. **It is extremely important that these identification plates are not painted over, removed, or in any other way rendered illegible.**

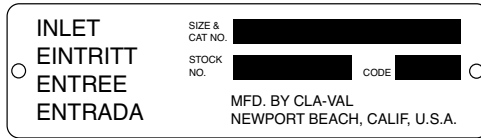

This brass plate appears on valves sized 2 1/2" and is located on the top of the inlet flange.

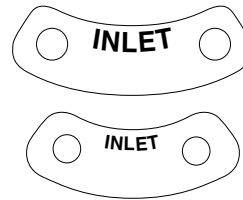

These two brass plates appear on 3/8", 1/2", and 3/4" size valves and are located on the valve cover.



This brass plate appears on altitude valves only and is found on top of the outlet flange.

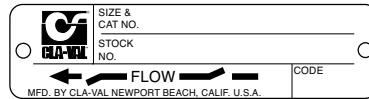

These two brass plates appear on threaded valves 1" through 3" size or flanged valves 1" through 2". It is located on only one side of the valve body.

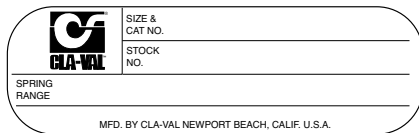

This tag is affixed to the cover of the pilot control valve. The adjustment range appears in the spring range section.

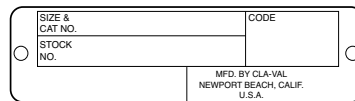

This brass plate is used to identify pilot control valves. The adjustment range is stamped into the plate.

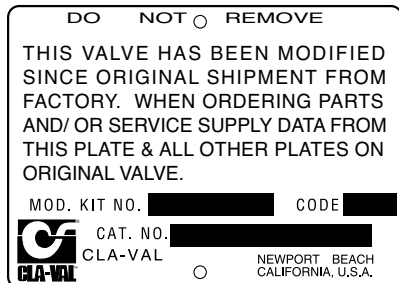

This aluminum plate is included in pilot system modification kits and is to be wired to the new pilot control system after installation.

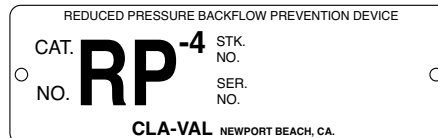

This brass plate is used on our backflow prevention assemblies. It is located on the side of the Number Two check (2" through 10"). The serial number of the assembly is also stamped on the top of the inlet flange of the Number One check.

HOW TO ORDER

Because of the vast number of possible configurations and combinations available, many valves and controls are not shown in published product and price lists. For ordering information, price and availability on product that are not listed, please contact your local Cla-Val office or our factory office located at:

P. O. Box 1325
Newport Beach, California 92659-0325
(949) 722-4800
FAX (949) 548-5441

SPECIFY WHEN ORDERING

- Model Number
- Globe or Angle Pattern
- Adjustment Range (As Applicable)
- Valve Size
- Threaded or Flanged
- Body and Trim Materials
- Optional Features
- Pressure Class

UNLESS OTHERWISE SPECIFIED

- Globe or angle pattern are the same price
- Ductile iron body and bronze trim are standard
- X46 Flow Clean Strainer or X43 "Y" Strainer are included
- CK2 Isolation Valves are included in price on 4" and larger valve sizes (6" and larger on 600 Series)

LIMITED WARRANTY

Automatic valves and controls as manufactured by Cla-Val are warranted for three years from date of shipment against manufacturing defects in material and workmanship that develop in the service for which they are designed, provided the products are installed and used in accordance with all applicable instructions and limitations issued by Cla-Val. Electronic components manufactured by Cla-Val are warranted for one year from the date of shipment.

We will repair or replace defective material, free of charge, that is returned to our factory, transportation charges prepaid, if upon inspection, the material is found to have been defective at time of original shipment. This warranty is expressly conditioned on the purchaser's providing written notification to Cla-Val immediate upon discovery of the defect.

Components used by Cla-Val but manufactured by others, are warranted only to the extent of that manufacturer's guarantee.

This warranty shall not apply if the product has been altered or repaired by others, Cla-Val shall make no allowance or credit for such repairs or alterations unless authorized in writing by Cla-Val.

DISCLAIMER OF WARRANTIES AND LIMITATIONS OF LIABILITY

The foregoing warranty is exclusive and in lieu of all other warranties and representations, whether expressed, implied, oral or written, including but not limited to any implied warranties or merchantability or fitness for a particular purpose. All such other warranties and representations are hereby cancelled.

Cla-Val shall not be liable for any incidental or consequential loss, damage or expense arising directly or indirectly from the use of the product. Cla-Val shall not be liable for any damages or charges for labor or expense in making repairs or adjustments to the product. Cla-Val shall not be liable for any damages or charges sustained in the adaptation or use of its engineering data and services. No representative of Cla-Val may change any of the foregoing or assume any additional liability or responsibility in connection with the product. The liability of Cla-Val is limited to material replacements F.O.B. Newport Beach, California.

TERMS OF SALE

ACCEPTANCE OF ORDERS

All orders are subject to acceptance by our main office at Newport Beach, California.

CREDIT TERMS

Credit terms are net thirty (30) days from date of invoice.

PURCHASE ORDER FORMS

Orders submitted on customer's own purchase order forms will be accepted only with the express understanding that no statements, clauses, or conditions contained in said order form will be binding on the Seller if they in any way modify the Seller's own terms and conditions of sales.

PRODUCT CHANGES

The right is reserved to make changes in pattern, design or materials when deemed necessary, without prior notice.

PRICES

All prices are F.O.B. Newport Beach, California unless expressly stated otherwise on our acknowledgement of the order. Prices are subject to change without notice. The prices at which any order is accepted are subject to adjustment to the Seller's price in effect at the time of shipment. Prices do not include sales, excise, municipal, state or any other Government taxes. Minimum order charge \$100.00.

RESPONSIBILITY

We will not be responsible for delays resulting from strikes, accidents, negligence of carriers, or other causes beyond our control. Also, we will not be liable for any unauthorized product alterations or charges accruing there from.

RISK

All goods are shipped at the risk of the purchaser after they have been delivered by to the carrier. Claims for error, shortages, etc., must be made upon receipt of goods.

EXPORT SHIPMENTS

Export shipments are subject to an additional charge for export packing.

RETURNED GOODS

1. Customers must obtain written approval from Cla-Val prior to returning any material.
2. Cla-Val reserves the right to refuse the return of any products.
3. Products more than six (6) months old cannot be returned for credit.
4. Specially produced, non-standard models cannot be returned for credit.
5. Rubber goods such as diaphragms, discs, o-rings, etc., cannot be returned for credit, unless as part of an unopened vacuum sealed repair kit which is less than six months old.
6. Goods authorized for return are subject to a 35% (\$100 minimum) restocking charge and a service charge for inspection, reconditioning, replacement of rubber parts, retesting, repainting and repackaging as required.
7. Authorized returned goods must be packaged and shipped prepaid to Cla-Val, 1701 Placentia Avenue, Costa Mesa, California 92627.



E-Product I.D. (R-3/2011)

CLA-VAL

PO Box 1325 Newport Beach CA 92659-0325
Phone: 949-722-4800 • Fax: 949-548-5441

CLA-VAL CANADA

4687 Christie Drive
Beamsville, Ontario
Canada L0R 1B4
Phone: 905-563-4963
Fax: 905-563-4040

CLA-VAL EUROPE

Chemin des Mesanges 1
CH-1032 Romanel/
Lausanne, Switzerland
Phone: 41-21-643-15-55
Fax: 41-21-643-15-50

©COPYRIGHT CLA-VAL 2011 Printed in USA
Specifications subject to change without notice.

www.cla-val.com

Represented By:



—MODEL— **REPAIR KITS**

Model 100-01 Hytrol Main Valve

BUNA-N MATERIAL				
	RUBBER KIT	REPAIR KIT	REBUILD KIT	STUD & NUT KIT
	STOCK NO.	STOCK NO.	STOCK NO.	STOCK NO.
3/8"	9169801K		21176614B	21176633J
1/2"	9169802H	21176602F	21176615A	21176634H
3/4"	9169802H	21176602F	21176615A	21176634H
1" Non-Guided	9169803F	21176601G	21176616K	21176636F
1"	9169804D	21176603E	21176617J	21176636F
1 1/4"	9169804D	21176603E	21176617J	21176636F
1 1/2"	9169804D	21176603E	21176617J	21176636F
2"	9169805A	21176608K	21176618H	21176637E
2 1/2"	9169811J	21176609J	21176619G	21176638D
3"	9169812G	21176604D	21176620D	21176639C
4"	9169813E	21176605C	21176621C	21176640K
6"	9169815K	21176606B	21176622B	21176641J
8"	9817901D	21176607A	21176623A	21176642H
10"	9817902B	21176610F	21176624K	21176643G
12"	9817903K	21176611E	21176625J	21176644F
14"	9817904H	21176612D	21176626H	21176645E
16"	9817905E	21176613C	21176627G	21176645E

Model 100-20 Hytrol Main Valve

BUNA-N MATERIAL				
	RUBBER KIT	REPAIR KIT	REBUILD KIT	STUD & NUT KIT
	STOCK NO.	STOCK NO.	STOCK NO.	STOCK NO.
3"	9169805A	21176608K	21176618H	21176637E
4"	9169812G	21176604D	21176620D	21176639C
6"	9169813E	21176605C	21176621C	21176640K
8"	9169815K	21176606B	21176622B	21176641J
10"	9817901D	21176607A	21176623A	21176642H
12"	9817902B	21176610F	21176624K	21176643G
14"	9817903K	21176611E	21176625J	21176644F
16"	9817903K	21176611E	21176625J	21176644F

Consult factory for larger sizes

Rubber Kit Includes: Diaphragm, Disc, Spacer Washers

Repair Kit Includes: Diaphragm, Disc, Spacer Washers, Epoxy Coated Disc Retainer, Epoxy Coated Diaphragm Washer, Protective Washer

Rebuild Kit Includes: Diaphragm, Disc, Spacer Washers, Epoxy Coated Disc Retainer, Epoxy Coated Diaphragm Washer, Protective Washer, Stainless Steel Bolts & Washers (6" & Below), Stainless Steel Studs, Nuts, & Washers (8" & Above), Stem, Stem Nut, Disc Guide

Stud & Nut Kit Includes: Stainless Steel Bolts & Washers (6" & Below), Stainless Steel Studs, Nuts, & Washers (8" & Above)

Repair Kits for 100-02/100-21 Powertrol and 100-03/100-22 Powercheck Main Valves

For: Powertrol and Powercheck Main Valves—150 Pressure Class Only

Includes: Diaphragm, Disc (or Disc Assembly) and O-rings and full set of spare Spacer Washers.

Valve Size	Kit Stock Number 100-02	Valve Size	Kit Stock Number	
			100-02 & 100-03	100-21 & 100-22
3/8"	9169901H	2 1/2"	9169910J	N/A
1/2" & 3/4"	9169902F	3"	9169911G	9169905J
1"	9169903D	4"	9169912E	9169911G
1 1/4" & 1 1/2"	9169904B	6"	9169913C	9169912E
2"	9169905J	8"	99116G	9169913C
		10"	9169939H	99116G
		12"	9169937B	9169939H

Larger Sizes: Consult Factory.

Repair Kits for 100-04/100-23 Hy-Check Main Valves

For: Hy-Check Main Valves—150 Pressure Class Only

Includes: Diaphragm, Disc and O-Rings and full set of spare Spacer Washers.

Valve Size	Kit Stock Number		Valve Size	Kit Stock Number	
	100-04	100-23		100-04	100-23
4"	20210901B	N/A	12"	20210905H	20210904J
6"	20210902A	20210901B	14"	20210906G	N/A
8"	20210903K	20210902A	16"	20210907F	20210905H
10"	20210904J	20210903K	20"	N/A	20210907F
			24"	N/A	20210907F

Larger Sizes: Consult Factory.

Repair Kits for Pilot Control Valves (In Standard Materials Only)

Includes: Diaphragm, Disc (or Disc Assembly), O-Rings, Gaskets or spare Screws as appropriate.

BUNA-N® (Standard Material)				VITON (For KB Controls)	
Pilot Control	Kit Stock Number	Pilot Control	Kit Stock Number	Pilot Control	Kit Stock Number
CDB	9170006C	CFM-9	12223E	CDB-KB	9170012A
CDB-30	9170023H	CRA (w/bucking spring)	9170001D	CRA-KB	N/A
CDB-31	9170024F	CRD (w/bucking spring)	9170002B	CRD-KB (w/bucking spring)	9170008J
CDB-7	9170017K	CRD (no bucking spring)	9170003K	CRL-KB	9170013J
CDH-2	18225D	CRD-18	20275401K	CDHS-2BKB	9170010E
CDHS-2	44607A	CRD-22	98923G	CDHS-2FKB	9170011C
CDHS-2B	9170004H	CRL (55F, 55L)	9170007A	CDHS-18KB (no bucking spring)	9170009G
CDHS-2F	9170005E	CRL60/55L-60	9170033G	102C-KB	1726202D
CDHS-3C-A2	24657K	CRL60/55L60 1"	9170042H		
CDHS-8A	2666901A	CRL-4A	43413E		
CDHS-18	9170003K	CRL-5 (55B)	65755B		
CDS-4	9170014G	CRL-5A (55G)	20666E		
CDS-5	14200A	CRL-18	20309801C		
CDS-6	20119301A	Universal CRL	9170041K		
CDS-6A	20349401C	CV	9170019F		
CFCM-M1	1222301C	X105L (O-ring)	00951E	Buna-N®	
CFM-2	12223E	102B-1	1502201F		
CFM-7	1263901K	102C-2	1726201F	CRD Disc Ret. (Solid)	C5256H
CFM-7A	1263901K	102C-3	1726201F	CRD Disc Ret. (Spring)	C5255K

Repair Assemblies (In Standard Materials Only)

Control	Description	Stock Number
CF1-C1	Pilot Assembly Only	89541H
CF1-CI	Complete Float Control less Ball and Rod	89016A
CFC2-C1	Disc, Distributor and Seals	2674701E
CSM 11-A2-2	Mechanical Parts Assembly	97544B
CSM 11-A2-2	Pilot Assembly Only	18053K
33A 1"	Complete Internal Assembly and Seal	2036030B
33A 2"	Complete Internal Assembly and Seal	2040830J

When ordering, please give complete nameplate data of the valve and/or control being repaired. MINIMUM ORDER CHARGE APPLIES

CLA-VAL

1701 Placentia Ave • Costa Mesa CA 92627 Phone: 949-722-4800 • Fax: 949-548-5441 • E-mail: info@cla-val.com • www.cla-val.com

© Copyright Cla-Val 2018 Printed in USA Specifications subject to change without notice.

N-RK (R-08/2018)