



— MODEL — **61-02**

Deep Well Pump Control Valve



- Prevent Surges in Pipelines
- Simple Hydraulic Operation
- Adjustable Opening and Closing Speeds
- Solenoid Control Can Be Operated Manually
- Proven Reliable Design

The Cla-Val Model 61-02 Deep Well Pump Control Valve is designed to protect pipelines from surges caused by the starting and stopping of deep well pumps. This is a hydraulically operated diaphragm valve which is controlled by a solenoid pilot valve. Separate adjustable flow control valves in the pilot system regulate the opening and closing rates. A limit switch on the valve stem serves as an electrical interlock between the valve and the pump motor.

The operation of the valve is completely automatic and controlled by the solenoid valve. With the pump off, the valve is wide open. When the pump is started, the solenoid is energized and the valve begins to close slowly, discharging air and the initial rush of sand and water from the pump column to atmosphere. As the valve closes the pump output is gradually diverted into the main line, preventing the development of a starting surge.

When it is time to shut-off the pump, the solenoid is de-energized. The pump continues to run while the pump control valve opens slowly, diverting pump output to atmosphere. As pump pressure gradually decreases, the main line check valve closes slowly, preventing shock or slam during the pump stopping cycle. When the pump control valve is wide open, the limit switch assembly releases the pump starter and the pump stops.

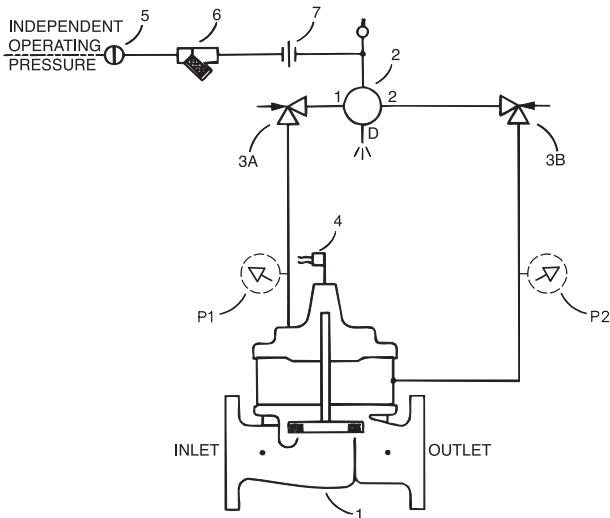

Schematic Diagram

Item	Description
1	100-02 Powertrol Main Valve
2	CSM11-A2-2 Solenoid Control
3	CV Flow Control
4	X105LOW Switch Assembly
5	CK2 Isolation Valve
6	X43 "Y" Strainer
7	Union

Options

Item	Description
P	X141 Pressure Gauge

Typical Installation

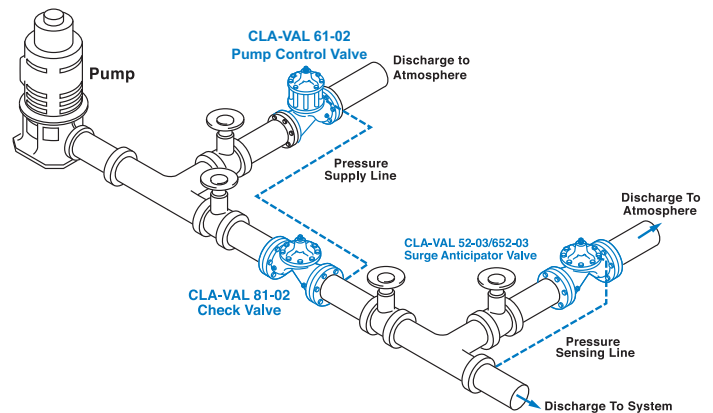

Install Model 61-02 valve as shown. Use a minimum of 1/2" tubing to connect operating pressure connection of the valve to the system side of check valve. Flexible conduit should be used for electrical connections to the solenoid control and the limit switch assembly. A Model 52-02 or 652-03 Surge Anticipator is recommended for power failure and surge protection.

Pressure Ratings (Recommended Maximum Pressure - psi)

Valve Body & Cover		Pressure Class			
		Flanged			Threaded
Grade	Material	ANSI Standards*	150 Class	300 Class	End‡ Details
ASTM A536	Ductile Iron	B16.42	250	640	400
ASTM A216-WCB	Cast Steel	B16.5	285	720	400
UNS 87850	Bronze	B16.24	225	500	400

Note: * ANSI standards are for flange dimensions only.
 Flanged valves are available faced but not drilled.
 ‡ End Details machined to ANSI B2.1 specifications.
Valves for higher pressure are available; consult factory for details

Materials

Component	Standard Material Combinations		
Body & Cover	Ductile Iron	Cast Steel	Bronze
100-02 Available Sizes	2-1/2" - 24"	2-1/2" - 16"	2-1/2" - 16"
Disc Retainer & Diaphragm Washer	Cast Iron	Cast Steel	Bronze
Trim: Disc Guide, Seat & Cover Bearing	Bronze is Standard Stainless Steel is Optional		
Disc	Buna-N® Rubber		
Diaphragm	Nylon Reinforced Buna-N® Rubber		
Stem, Nut & Spring	Stainless Steel		

For material options not listed, consult factory.
 Cla-Val manufactures valves in more than 50 different alloys.

Model 61-02 (uses 100-02 Powertrol Main Valve)

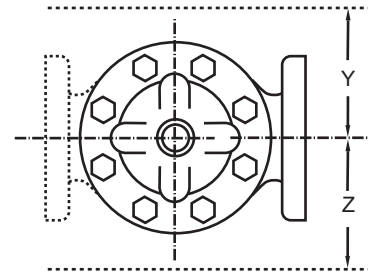
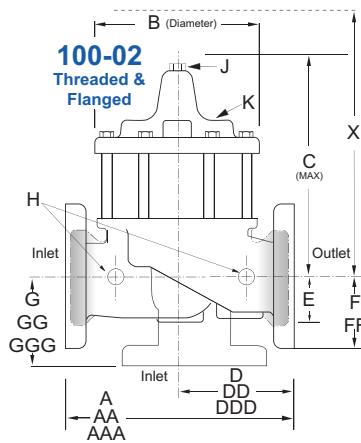

61-02 Series Dimensions (In Inches)

Valve Size (Inches)	2 1/2	3	4	6	8	10	12	14	16	18	20	24
A Threaded	11.00	12.50	—	—	—	—	—	—	—	—	—	—
AA 150 ANSI	11.00	12.00	15.00	20.00	25.38	29.75	34.00	39.00	41.38	46.00	52.00	61.50
AAA 300 ANSI	11.62	13.25	15.62	21.00	26.38	31.12	35.50	40.50	43.50	47.64	53.62	63.24
AAAA Grooved End	11.00	12.50	15.00	20.00	25.38	—	—	—	—	—	—	—
B Diameter	8.00	9.12	11.50	15.75	20.00	23.62	28.00	32.75	35.50	41.50	45.00	53.16
C Maximum	10.31	11.19	14.25	18.44	21.81	23.38	29.31	32.12	35.00	49.43	53.09	56.50
CC Maximum Grooved End	9.63	10.25	13.50	17.18	20.43	—	—	—	—	—	—	—
D Threaded	5.50	6.25	—	—	—	—	—	—	—	—	—	—
DD 150 ANSI	5.50	6.00	7.50	10.00	12.69	14.88	17.00	19.50	20.81	—	—	—
DDD 300 ANSI	5.88	6.38	7.88	10.50	13.25	15.56	17.75	20.25	21.62	—	—	—
DDDD Grooved End	—	6.00	7.50	—	—	—	—	—	—	—	—	—
E	1.69	2.06	3.19	4.31	5.31	9.25	10.75	12.62	15.50	12.95	15.00	17.75
EE Grooved End	2.88	3.12	4.25	6.00	7.56	—	—	—	—	—	—	—
F 150 ANSI	3.50	3.75	4.50	5.50	6.75	8.00	9.50	10.50	11.75	15.00	16.50	19.25
FF 300 ANSI	3.75	4.13	5.00	6.25	7.50	8.75	10.25	11.50	12.75	15.00	16.50	19.25
G Threaded	4.00	4.50	—	—	—	—	—	—	—	—	—	—
GG 150 ANSI	4.00	4.00	5.00	6.00	8.00	8.62	13.75	14.88	15.69	—	—	—
GGG 300 ANSI	4.31	4.38	5.31	6.50	8.50	9.31	14.50	15.62	16.50	—	—	—
GGGG Grooved End	—	4.25	5.00	—	—	—	—	—	—	—	—	—
H NPT Body Tapping	0.50	0.50	0.75	0.75	1.00	1.00	1.00	1.00	1.00	1.00	1.00	1.00
J NPT Cover Center Plug	0.50	0.50	0.75	0.75	1.00	1.00	1.25	1.50	2.00	1.50	1.50	1.50
K NPT Cover Tapping	0.50	0.50	0.75	0.75	1.00	1.00	1.00	1.00	1.00	1.00	1.00	1.00
Stem Travel	0.70	0.80	1.10	1.70	2.30	2.80	3.40	4.00	4.50	5.10	5.63	6.75
Approx. Ship Weight (lbs)	65	95	190	320	650	940	1675	2460	3100	4300	5400	8150
Approx. X Pilot System	17.00	18.00	21.00	34.00	37.00	39.00	45.00	48.00	50.00	50.00	50.00	68.00
Approx. Y Pilot System	10.00	11.00	12.00	20.00	22.00	24.00	26.00	29.00	30.00	30.00	30.00	39.00
Approx. Z Pilot System	10.00	11.00	12.00	20.00	22.00	24.00	26.00	29.00	30.00	30.00	30.00	39.00

61-02 Valve Selection	100-02 Pattern: Globe (G), Angle (A), End Connections: Threaded (T), Flanged (F) Indicate Available Sizes												
	Inches	2½	3	4	6	8	10	12	14	16	18	20	24
	mm	65	80	100	150	200	250	300	350	400	450	500	600
Main Valve 100-02	Pattern	G, A	G, A	G, A	G, A	G, A	G, A	G, A	G, A	G, A	G	G	G, A
	End Detail	T, F	T, F	F	F	F	F	F	F	F	F	F	F
Suggested Flow (gpm)	Maximum	300	460	800	1800	3100	4900	7000	8400	11000	14000	17000	25000
	Maximum Intermittent	370	580	990	2250	3900	6150	8720	10540	13700	17500	21700	31300
Suggested Flow (Liters/Sec)	Maximum	19	29	50	113	195	309	442	530	694	883	1073	1577
	Maximum Intermittent	23	37	62	142	246	387	549	664	863	1104	1369	1972

100-02 Series is the full internal port Powertrol Main Valve.

CSM11 Solenoid Control Power Consumption

Volts	Amperes		Coil Resistance
AC 60 Hz	Holding	Inrush	Ohms
24	2.88	25.4	0.5
120	.575	5.1	14.1
208	.330	2.93	40
240	.288	2.54	58
440	.156	1.38	174
440	.143	1.27	233
Volts	Amperes		Coil Resistance
(AC 50 Hz)	Holding	Inrush	Ohms
110	.48	4.6	15.7
220	.24	2.3	66
240	.22	2.1	88



CSM11 Specifications

Enclosure General purpose NEMA Type 3; Aluminum
 Note: For other enclosures and NEMA Types, consult factory

Housing Body — Aluminum
 Trim — Stainless Steel

Operating Pressure: Maximum pressure 300 psi, for higher pressure consult factory.

Coil Insulation Class A (molded)

AC voltage 15.4 watts

Pilot System Specifications

Temperature Range

Water to 180°F Max

Materials

Standard Pilot System Materials

Pilot Control: Low Lead Bronze

Trim: Stainless Steel Type 303

Rubber: Buna-N® Synthetic Rubber

Optional Pilot System Materials

Pilot Systems are available with optional Aluminum, Stainless Steel or Monel materials.

Wiring Diagram

Auto-Off-Hand	= Selector Switch
1CR	= Relay, DPST Normally Open
2CR	= Relay, DPST Normally Open
3CR	= Relay, TPST Normally Open
SW ₁	= Switch, Remote Start, Automatic
SW ₂	= Switch, SPDT, Valve Limit Switch Connect to N.C. Terminal
PVS	= Pilot Valve Solenoid
M	= Pump Motor Starter

Note: SW₂ and PVS supplied by Cla-Val. All other electrical items supplied by customer. SW₂ is included in the X105L switch assembly which is mounted on the pump control valve cover.

Shown In Pump Off Position

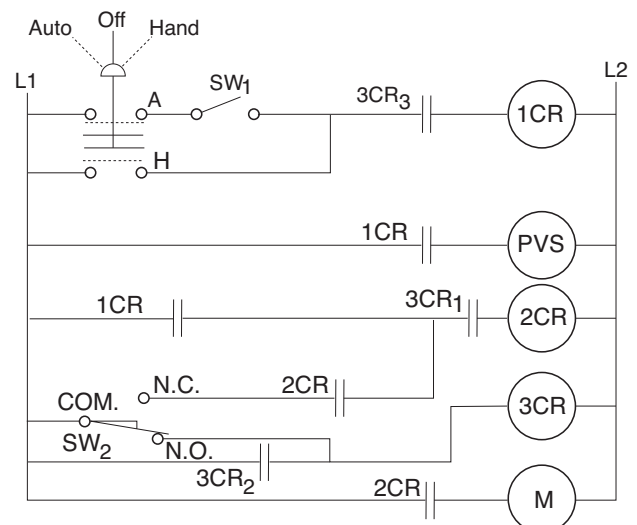

Sequence Of Operation

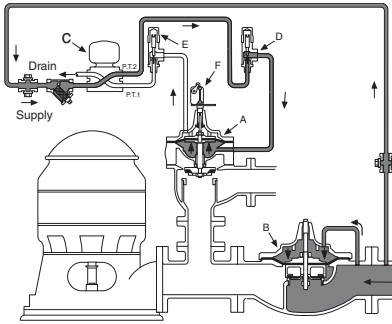

Pump Off...

With pump off, static line pressure holds the main line check valve "B" closed. Line pressure is transmitted through solenoid control "C" and speed control "D" to the lower chamber of valve "A". Upper chamber of pump control valve "A" is vented to atmosphere so valve "A" is held wide open.

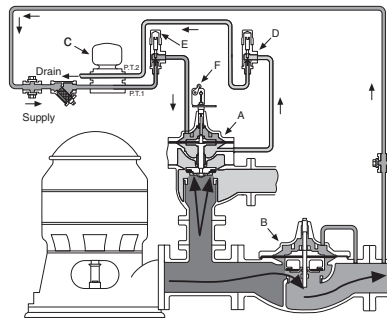

Starting Cycle...

Starting switch closes, pump starts, solenoid "C" energizes and shifts, allowing line pressure to flow into upper chamber of valve "A" through solenoid control "C" and opening speed control "E". Closing speed of valve "A" is controlled by speed control "D" which limits the rate fluid is relieved from under the diaphragm. As valve "A" closes, pumping pressure opens main line check valve "B", gradually permitting full flow.

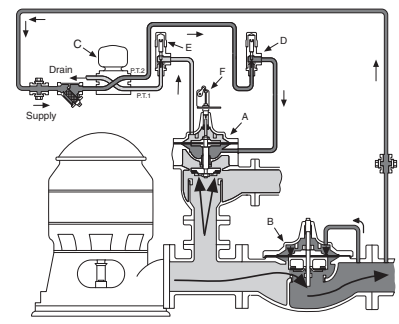

Stopping Cycle...

Starting switch opens, solenoid "C" de-energizes and shifts, as pump continues to run, pump pressure flows into lower chamber of valve "A" through solenoid "C" and opening speed control "D". Pressure in upper chamber of valve "A" is relieved to atmosphere through opening speed control "E" and solenoid control "C". As valve "A" opens, flow through main line check valve "B" gradually lessens until valve "A" is wide open and the limit switch "F" shuts off the pump.

Selecting The Valve

To be effective, this valve must be sized so it relieves to atmosphere that part of the pump discharge head which is in excess of the normal system static pressure. To do this, the valve is sized to permit the full pump discharge through the valve at a pressure low enough to keep the system check valve from opening. As the pump control valve closes, the pumping pressure exceeds the system pressure and gradually flows into the system.

We recommend selecting a valve size which will have a pressure loss that is at least 10 psi less than the system static pressure. Use the flow rate which is found on the pump's flow vs discharge pressure chart. Select the flow corresponding to the system static pressure, less 10 psi.

Determining Valve Size

1. Determine the system's static pressure (the pressure downstream of the check valve with the pump off); subtract 10 psi, this is the Design Pressure P.
2. From the pump's flow vs. discharge pressure curve, determine the flow (Q) at the Design Pressure P.
3. Using the formula, calculate the Cv.

$$Cv = \frac{Q}{\sqrt{P}}$$

4. Select the valve size from the table which has a Cv that is equal to, or greater than, the calculated Cv in step 3 above.

Example

1. System Static Pressure with the pump off = 70 psi.
2. Determine the Design Pressure P by subtracting 10 psi (70 psi - 10 psi = 60 psi Design Pressure)
3. From the pump curve we determine that the valve must allow a flow of 800 GPM at 60 psi.
4. Using the Formula:

$$Cv = \frac{Q}{\sqrt{P}} \quad \text{Where: } Q = 800 \text{ GPM} \\ P = 60 \text{ psi (70 psi - 10 psi)}$$

$$\text{Example } Cv = \frac{800}{\sqrt{60}} = 103$$

61-02 Valve Selection Chart Cv Values

Valve Size	Globe	Angle
2½	85	101
3	115	139
4	200	240
6	460	541
8	770	990
10	1245	1575
12	1725	2500
14	2300	3060
16	2940	4200
18	3725	--
20	5345	--
24	7655	--

Example (continued)

5. From the table above the best valve choice is:
3" 61-02 Globe Pattern

Drain Provisions

Each time the valve opens or closes, water is discharged from the solenoid exhaust port, the amount varying with the valve size. Provisions should be made for the disposal of this water. Exhaust tube must be free of any back pressure. Provide an air gap between the solenoid exhaust tube and drain facility.

When Ordering, Specify:

1. Catalog No. 61-02
2. Valve Size
3. Pattern - Globe or Angle
4. Pressure Class
5. Trim Material
6. Electrical Selection
7. Desired Options
8. When Vertically Installed