



—MODEL— **90-48/690-48**

Pressure Reducing Valve with Low Flow By-Pass

The Cla-val Model 90-48 Pressure Reducing Valve with Low Flow By-Pass automatically reduces a higher inlet pressure to a steady lower downstream pressure regardless of changing flow rate. The pressure reducing valve is hydraulically operated and controlled by a CRD pilot control, which senses pressure at the main valve outlet. An increase in outlet pressure forces the CRD pilot control to close and a decrease in outlet pressure opens the control. This causes the main valve cover pressure to vary, modulating the main valve and thereby maintaining constant outlet pressure. The control system is very sensitive to slight pressure changes and immediately controls the main valve to maintain the desired downstream pressure. Pressure setting adjustment is made with a single adjusting screw

INSTALLATION

1. Allow sufficient room around the valve assembly to make adjustments and for servicing.
2. It is recommended that gate or line block valves be installed on both ends of the 90-48/690-48 valve assembly to facilitate isolating the valve for maintenance. Minimum one pipe diameter apart.

NOTE: BEFORE THE VALVE IS INSTALLED, PIPE LINES SHOULD BE FLUSHED OF ALL CHIPS, SCALE, AND FOREIGN MATTER.

3. Place the valve assembly in the line with flow through the valve in the direction indicated on the inlet plate or by flow arrows. Check all fittings and hardware for proper makeup and that no apparent damage is evident. Be sure main valve cover nuts/bolts are tight. Pressure in some applications can be very high so be thorough in checking and inspecting for proper installation and makeup.
4. Cla-Val Valves operate with maximum efficiency when mounted in horizontal piping with the cover UP; however, other positions are acceptable. Due to size and weight of cover and internal components of six inch and larger valves, installation with the cover up is advisable. This makes periodic inspection of internal parts readily accessible.
5. Caution must be taken in the installation of this valve to insure that galvanic and/or electrolytic action does not take place. The proper use of dielectric fittings and gaskets are required in all systems using dissimilar metals.

OPERATION AND START-UP

1. Prior to pressurizing the valve assembly make sure the necessary gauges to measure pressure in the system are installed as required by the system engineer. A Cla-Val X101 Valve Position Indicator may be installed in the center cover port to provide a visual indication of the valve movement during startup.

CAUTION: During start-up and test procedures a large volume of water may be discharged downstream. Check that the downstream venting is adequate to prevent damage to personnel and equipment. **All adjustments in pressure should be made slowly while under flowing conditions.** If the main valve closes too fast it may cause surging in upstream piping.

2. If isolation valves (B) are installed in pilot system open these valves (see schematic).
3. Optional Cla-Val CV Flow Controls (C or S) provide adjustable regulation of flow in and out of the main valve chamber to minimize pulsations that sometime occur at very low flow rates. If CV Controls are installed, loosen jam nut and turn adjustment screw counterclockwise from closed position 3.5 turns for an initial setting.
4. Open the upstream gate or block valve just slightly to allow the main valve assembly and pilot system to fill with liquid. Downstream gate or block valve must be closed.
5. Carefully loosen tube fittings at highest points and bleed air from pilot control system. Carefully loosen the plug at top of main valve cover to bleed air from cover. If an indicator is installed, carefully loosen the air bleed valve at top of indicator. Tighten tube fittings.
6. Open the upstream gate or block valve fully.
7. Slowly open the downstream gate or block valve. Flow should occur and pressure should remain constant.
8. Adjust the Pilot Controls to desired pressure. To change pressure setting, turn the adjusting screw clockwise to increase pressure, counterclock-

wise to decrease pressure. There must be liquid flowing through the valve during pressure adjustments. When the desired setting has been made, tighten jam nut and replace CRD cover. Low flow by-pass control (4) must be set higher (minimum 5 psi) than main CRD (3).

9. To check the operation of the valve, open and close the downstream gate valve. The downstream pressure should remain constant.
10. If opening and closing speed controls (C or S) are installed in the valve pilot system, fine tune the opening and closing speed of the main valve while performing step 9. Turn the CV adjustment screw clockwise on the opening speed control to make the main valve open slower. Turn the adjustment screw clockwise on the closing speed control to make the main valve close slower. When adjustments have been completed tighten jam nuts.

MAINTENANCE

1. Cla-Val Valves and Controls require no lubrication or packing and a minimum of maintenance. However, a periodic inspection schedule should be established. Minimum of once per year.
2. Repair and maintenance procedures of the Cla-Val Hytrol Main Valve and pilot control components are included in a more detailed IOM manual. It can be downloaded from our web site (www.cla-val.com) or obtained by contacting a Cla-Val Regional Sales Office.
3. **When ordering parts always refer to the catalog number and stock number on the valve nameplate.**

SYMPTOM	PROBABLE CAUSE	REMEDY
Main valve fails to open	No pressure at valve inlet	Check inlet pressure
	Main valve diaphragm assembly inoperative	Disassemble, clean and polish stem, replace defective parts
	Pilot Valve (CRD) not opening: 1. No spring compression 2. Damaged spring 3. Spring guide not in place 4. Yoke dragging on inlet nozzle	1. Tighten adjusting screw 2. Disassemble and replace 3. Assemble properly 4. Assemble properly
	Flow Control (CV) disc inoperative, corrosion or excessive scale buildup on stem	Disassemble, clean and polish stem. Replace worn parts
Main valve fails to close	Foreign matter between disc and seat or worn disc. Scale on stem or diaphragm ruptured	Disassemble main valve, remove matter, clean parts and replace defective parts
	Flow Clean Strainer plugged	Remove and clean or replace
	CK2 (isolation valves) closed	Open isolation valves
Fails to regulate	Pilot Valve (CRD) remains open: 1. Spring compressed solid 2. Mechanical obstruction 3. Worn disc 4. Yoke dragging on inlet nozzle diaphragm nut 5. Diaphragm damaged or loose diaphragm nut. Leakage from vent hole in cover	1. Back off adjusting screw 2. Disassemble and remove obstruction 3. Disassemble remove and replace disc retainer assembly 4. Assemble properly 5. Disassemble, replace diaphragm and/or tighten nut
	Air in main valve cover and/or tubing	Loosen top cover plug and fittings and bleed air
	Pilot Valve (CRD) yoke dragging on inlet nozzle	Assemble properly
	Pilot Valve (CRD) spring not in correct range to control	Check outlet pressure requirements and compare existing spring with Spring Chart

90-48/690-48 SCHEMATIC

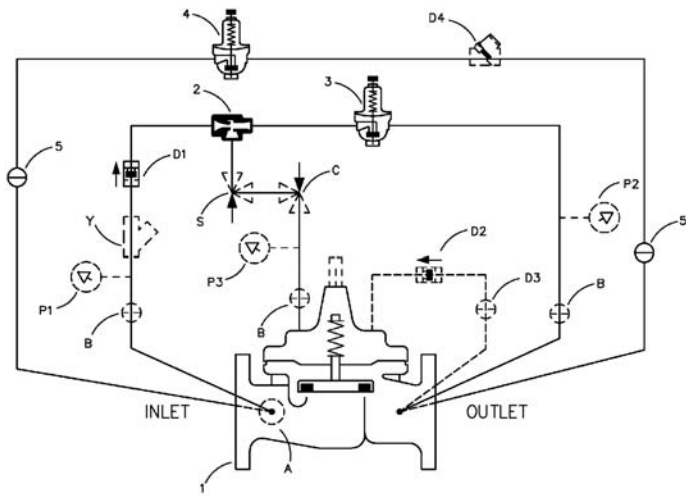

BASIC COMPONENTS

- 1 100-01 Hytrol (Main Valve)
- 2 X47A Restriction Fitting
- 3 CRD Pressure Reducing Control
- 4 CRD-L Pressure Reducing Control
- 5 CK2 (Isolation Valve)

OPTIONAL FEATURES

- A X46A Flow Clean Strainer
- B CK2 (Isolation Valve)
- C Closing Speed Control
- D Check Valves with Isolation Valve
- P X141 Pressure Gauge
- S Opening Speed Control
- V X101 Valve Position Indicator
- Y X43 "Y" Strainer

CRD

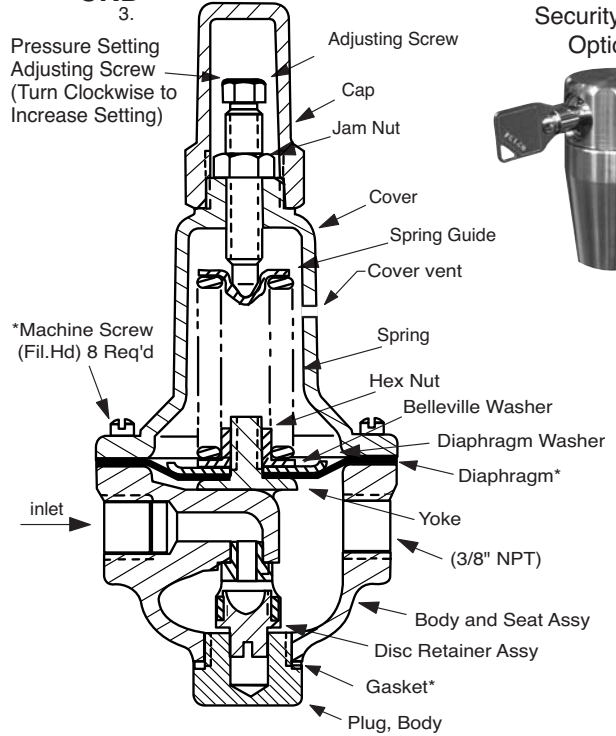

X140-1 Security Cap Option



CRD adjust range (psi)	Spring Color	psi change per turn*
2 - 30	Stainless Steel	3
15 - 75	Red	9
20-105	Stainless Steel	12
30 - 300	Green	27

* approximate. Use gauge at valve outlet to set

Low Flow ByPass (set higher)

CRD-L Adjustment Range
15 to 65 psi
25 to 100 psi
80 to 150 psi

Use gauge at valve outlet to set

MAIN VALVE

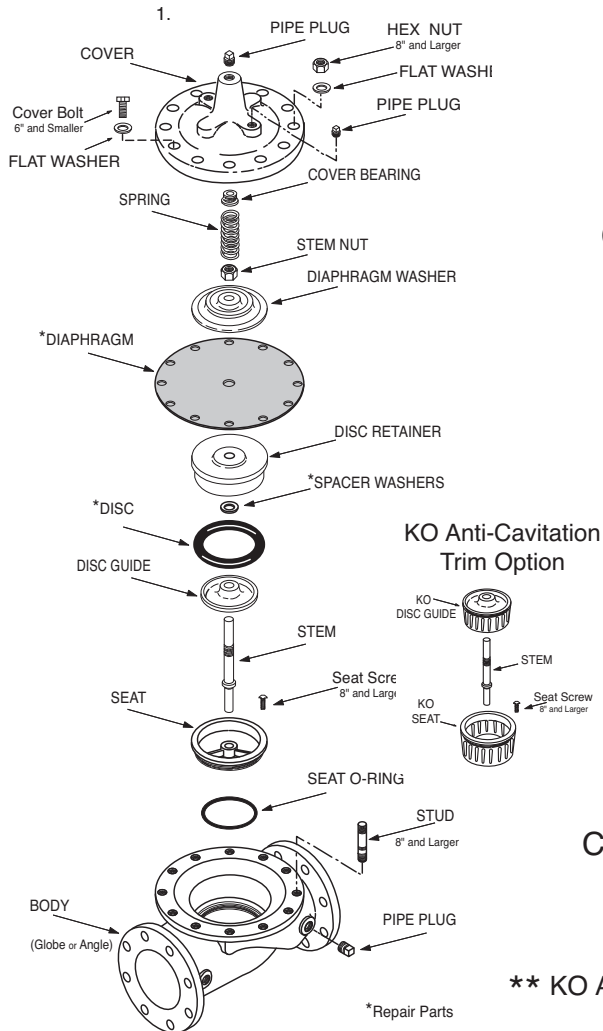

CRD-L
4.



X47A
2.



CK2
5.



CDC-1
D.



X46A
A.



CV
C.



X43
Y.



** KO ANTI-CAVITATION TRIM CAN BE ADDED TO ANY STANDARD HYTROL VALVE