

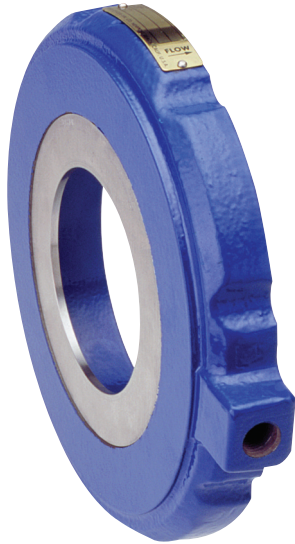

—MODEL— **X52E**

Orifice Plate Assembly

- Wafer Design
- Fits ANSI 125, 150, 250, 300
- Optional Materials Available
- Easy to use size Selection Chart



The Cla-Val Model X52E Orifice Plate Assembly is typically used with Cla-Val flow control valves. The orifice plate is an essential component used to generate a specific, predictable pressure drop in the system. The X52E uses a wafer design holder which offers a compact light-weight assembly that is easy to install. The X52E has a Chamfered "Inlet" side so even after installation, correct orientation can be easily verified.

The orifice plate portion of the assembly is made of 302 stainless steel with other materials options also available. The plate is machined to a recommended "square edge". The plate holder portion of the assembly is Ductile Iron standard. Fusion-bonded epoxy coating is an option. The holder may be made of other materials.

Selecting an orifice plate bore size is made by using charts provided.

We recommend installation of this assembly with the sensing port to the side of the pipeline to prevent air pockets and obstructions in the sensing line. Installation adjacent to a butterfly valve is not recommended as the orifice plate assembly may interfere with the opening of this type of valve.

Dimensions

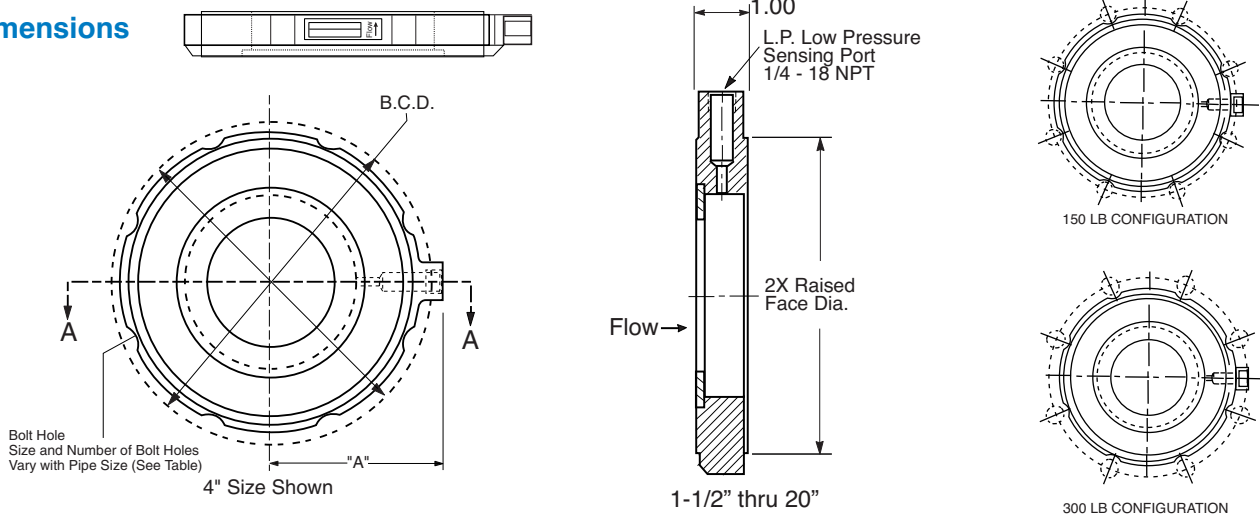

NOMINAL PIPE SIZE (inches)	1-1/2	2	2-1/2	3	4	6	8	10	12	14	16	18	20	24	30*	36*
Diameter of Flange	3.63	4.25	5.00	5.75	7.00	9.75	12.00	14.14	16.50	19.00	21.12	23.50	25.62	Refer to E-X52A-1 Sheet	Consult Factory	
Diameter of Raised Face	2.88	3.63	4.13	5.00	6.19	8.50	10.63	12.75	15.00	16.25	18.50	21.00	23.00			
"A" Dim from CL to top of boss	2.31	2.62	3.00	3.38	4.00	5.38	6.50	7.62	8.75	10.00	11.06	12.50	13.75			
Diameter of Bolt Circle (B.C.D.)	3.88	4.75	5.50	6.00	7.50	9.50	11.75	14.25	17.00	18.75	21.25	22.75	25.00			
150 Lb.	Number of Bolts	4	4	4	4	8	8	8	12	12	12	16	16			
	Radius of Bolt Holes	.31	.38	.38	.38	.38	.44	.44	.50	.50	.56	.56	.62	.62		
300 Lb.	Diameter of Bolt Circle	4.50	5.00	5.50	6.63	7.88	10.63	13.00	15.25	17.75	20.25	22.50	24.75	27.00		
	Number of Bolts	4	8	8	8	8	12	12	16	16	20	20	24	24		

*Consult Factory

Sizing An Orifice Plate Bore: Example

1. In determining a bore size, the nominal flow rate (or range of flow) and the pipe size in which the orifice plate assembly will be installed must be known.
2. Sizing a bore for:

A constant flow rate:

Select the sizing chart that matches pipe size and locate the flow rate under the nominal column which is closest to required flow; select the corresponding bore size dimension.

Example:

A 6" pipe with a desired constant flow of 700 gpm. Using the 6" chart, the closest flow in the nominal column is 670 gpm which has a corresponding bore size of 3.80".

6" Valve / Pipe Size			
Bore Size	Flow - gpm		
	Min.	Max.	Nominal
4.60	490	1960	1100
4.40	435	1740	980
4.20	380	1520	850
4.00	330	1320	750
3.80	300	1200	670
3.60	265	1060	590
3.40	230	920	520
3.20	200	800	450
3.00	175	700	395
2.80	150	600	340
2.60	130	520	295
2.40	110	440	245

A flow range:

Select the sizing chart that matches pipe size and locate required flow range between the minimum and maximum limits of an orifice bore. Frequently the flow range will fit between more than one bore size. To resolve this, decide the flow rate that system will be operated at most frequently. Locate the flow which is closest to this under the nominal flow column, and select the corresponding bore size dimension.

Example:

A 6" pipe with a flow range of 300-1000 gpm. Using the 6" chart, more than one bore size can accommodate this range. The most frequent flow rate will be 500 gpm. Using the nominal flow column, the closest flow is 520 gpm which has a corresponding bore size of 3.40"

6" Valve / Pipe Size			
Bore Size	Flow - gpm		
	Min.	Max.	Nominal
4.60	490	1960	1100
4.40	435	1740	980
4.20	380	1520	850
4.00	330	1320	750
3.80	300	1200	670
3.60	265	1060	590
3.40	230	920	520
3.20	200	800	450
3.00	175	700	395
2.80	150	600	340
2.60	130	520	295
2.40	110	440	245

Orifice Plate Bore Charts

1 ½" Valve / Pipe Size			
Bore Size	Flow - gpm		
	Min.	Max.	Nominal
1.20	35	142	61
1.00	21	85	37
0.80	13	51	22
0.70	10	38	16
0.60	7	28	12
0.50	5	19	8

2" Valve / Pipe Size			
Bore Size	Flow - gpm		
	Min.	Max.	Nominal
1.55	55	220	125
1.50	50	200	115
1.40	42	168	95
1.20	29	116	65
1.00	19	76	45
.80	12	50	28

Orifice Plate Bore Charts

2 ½" Valve / Pipe Size			
Bore Size	Flow - gpm		
	Min.	Max.	Nominal
1.87	80	330	180
1.60	55	220	120
1.40	40	160	88
1.20	28	115	62
1.00	19	80	43
.80	12	50	28

4" Valve / Pipe Size			
Bore Size	Flow - gpm		
	Min.	Max.	Nominal
3.00	205	820	450
2.80	170	680	390
2.60	140	560	310
2.40	115	460	260
2.20	96	384	215
2.00	78	312	175
1.80	63	252	140
1.60	49	196	110
1.40	38	152	84
1.20	28	112	62

8" Valve / Pipe Size			
Bore Size	Flow - gpm		
	Min.	Max.	Nominal
6.00	830	3320	1850
5.80	760	3040	1700
5.60	680	2720	1550
5.40	620	2480	1400
5.20	570	2280	1275
5.00	515	2060	1150
4.80	470	1800	1050
4.60	425	1700	950
4.40	385	1540	860
4.20	345	1380	780
4.00	310	1240	700

12" Valve / Pipe Size			
Bore Size	Flow - gpm		
	Min.	Max.	Nominal
9.00	1850	7400	4200
8.50	1575	6300	3500
8.00	1350	5400	3000
7.50	1150	4600	2600
7.00	980	3920	2200
6.50	840	3360	1875
6.00	700	2800	1575
5.50	580	2320	1300
5.00	480	1920	1075
4.50	385	1540	870

3" Valve / Pipe Size			
Bore Size	Flow - gpm		
	Min.	Max.	Nominal
2.29	120	480	270
2.20	105	420	240
2.00	84	336	190
1.80	65	260	145
1.60	50	200	115
1.40	38	152	86
1.20	28	112	62
1.00	19	76	43

6" Valve / Pipe Size			
Bore Size	Flow - gpm		
	Min.	Max.	Nominal
4.60	490	1960	1100
4.40	435	1740	980
4.20	380	1520	850
4.00	330	1320	750
3.80	300	1200	670
3.60	265	1060	590
3.40	230	920	520
3.20	200	800	450
3.00	175	700	395
2.80	150	600	340
2.60	130	520	295
2.40	110	440	245

10" Valve / Pipe Size			
Bore Size	Flow - gpm		
	Min.	Max.	Nominal
7.50	1300	5200	2900
7.00	1075	4300	2400
6.50	880	3520	1950
6.00	730	2920	1650
5.50	600	2400	1350
5.00	490	1960	1100
4.50	390	1560	870
4.00	310	1240	690
3.50	235	940	525
3.00	175	700	385

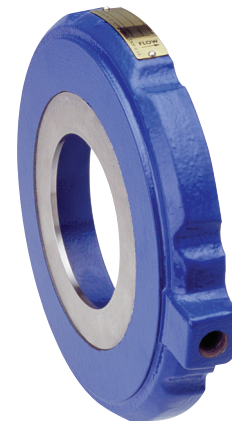

Orifice Plate Bore Charts (continued)

14" Valve / Pipe Size			
Bore Size	Flow - gpm		
	Min.	Max.	Nominal
10.00	2350	9400	5200
9.50	2025	8100	4500
9.00	1750	7000	3900
8.50	1500	6000	3400
8.00	1300	5200	2900
7.50	1150	4600	2500
7.00	960	3840	2150
6.50	820	3280	1850
6.00	700	2800	1550
5.50	585	2340	1300
5.00	480	1920	1075
4.50	385	1540	860

18" Valve / Pipe Size			
Bore Size	Flow - gpm		
	Min.	Max.	Nominal
13.00	5200	15500	9000
12.00	4100	12300	7100
11.50	3700	11000	6400
11.00	3300	9850	5700
10.50	2950	8800	5100
10.00	2600	7850	4550
9.50	2350	6200	3600
9.00	2100	6200	3600
8.50	1850	5500	3200
8.00	1650	4850	2800
7.50	1400	4250	2450
7.00	1250	3650	2100

24" Valve / Pipe Size			
Bore Size	Flow - gpm		
	Min.	Max.	Nominal
17.00	8500	25500	15000
16.00	7500	21500	12500
15.00	6100	18400	10500
14.50	5700	17000	9800
14.00	5200	15600	9000
13.50	4800	14400	8300
13.00	4400	13200	7600
12.50	4000	12100	7000
12.00	3700	11100	6400
11.50	3400	10100	5800
11.00	3100	9200	5300
10.50	2800	8300	4800
10.00	2500	7500	4400

16" Valve / Pipe Size			
Bore Size	Flow - gpm		
	Min.	Max.	Nominal
11.50	3100	12400	7000
11.00	2700	10800	6100
10.50	2400	9600	5400
10.00	2100	8400	4700
9.50	1850	7400	4200
9.00	1650	6600	3650
8.50	1450	5800	3250
8.00	1250	5000	2850
7.50	1100	4400	2450
7.00	950	3800	2150
6.50	810	3240	1800
6.00	700	2800	1550

20" Valve / Pipe Size			
Bore Size	Flow - gpm		
	Min.	Max.	Nominal
14.00	6000	18000	10500
13.50	5300	16000	9500
13.00	4800	14500	8500
12.50	4300	12900	7500
12.00	3900	11700	6700
11.50	3400	10500	6100
11.00	3200	9500	5500
10.50	2900	8600	5000
10.00	2600	7700	4500
9.50	2300	6100	3600
9.00	2000	6100	3600
8.50	1800	5400	3200

36" Valve / Pipe Size			
Bore Size	Flow - gpm		
	Min.	Max.	Nominal
26.00	20000	60000	35000
24.00	16000	48500	28000
22.00	13000	39000	22500
21.00	12000	35000	20500
20.00	10500	31000	18000
19.00	9500	28000	16000
18.00	8500	24500	14500
17.00	7500	22000	12500
16.00	6500	19300	11000
15.00	5600	16900	9800
14.00	4900	14600	8500
13.00	4200	12600	7300