



– MODEL – **CRA**
 REMOTE SENSING TYPE

Pressure Reducing Control

DESCRIPTION

The CRA Pressure Reducing Control automatically reduces a higher inlet pressure to a lower outlet pressure. It is a direct acting, spring loaded, diaphragm type valve that operates hydraulically or pneumatically and is designed to sense pressure from a remote point. It may be used as a self-contained valve or as a pilot control for a Cla-Val Co. main valve. It will hold a constant downstream pressure at the remote sensing point within very close pressure limits.

OPERATION

The CRA Pressure Reducing Control is normally held open by the force of the compression spring above the diaphragm; delivery pressure acts on the underside of the diaphragm. Flow through the valve responds to changes in pressure at the the sensing point.

INSTALLATION

The CRA Pressure Reducing Control may be installed in any position. There is one inlet port and two outlets, for either straight or angle installation. The second outlet port can be used for a gauge connection. A flow arrow is marked on the body casting.

ADJUSTMENT PROCEDURE

The CRA Pressure Reducing Control can be adjusted to provide a delivery pressure range as specified on the nameplate.

Pressure adjustment is made by turning the adjustment screw to vary the spring pressure on the diaphragm. The greater the compression on the spring the higher the pressure setting.

1. Turn the adjustment screw in (clockwise) to increase delivery pressure.
2. Turn the adjustment screw out (counter-clockwise) to decrease the delivery pressure. When pressure adjustment is completed, tighten jam nut on adjustment screw and replace protective cap.

Flow rates are not critical during pressure setting. The approximate minimum flow rates given in the table are for the main valve on which the CRA is installed.

Valve Size	1 ¼"-3"	4"-8"	10"-16"
Minimum Flow GPM	15-30	50-200	300-650

MAINTENANCE

Disassembly

To disassemble follow the sequence of the item numbers assigned to parts in the sectional illustration.

Reassembly

Reassembly is the reverse of disassembly. Caution must be taken to avoid having the yoke (17) drag on the inlet nozzle of the body (18). Follow this procedure:

1. Place yoke (17) in body and screw the disc retainer assembly (16) until it bottoms.
2. Install gasket (14) and spring (19) for 2-30 psi range onto plug (13) and screw into body. Disc retainer must enter guide hole in plug as it is assembled. Screw the plug in by hand. Use wrench to tighten only.
3. Place gasket (25) and powertrol body (21) on yoke extension (17). Refer to sectional view for proper reassembly of (21) onto body (18).
4. Place lower diaphragm washer (24), "o" ring (22), diaphragm (12), upper diaphragm washer (11), and bellville washer (20) on yoke extension (17). Screw on diaphragm nut (10) finger tight.
5. Place two machine screws (4) through (21) (25) and screw into body (18). Do not include the diaphragm (12) in this operation. This holds parts aligned for next step, and allows the diaphragm to move and be properly located during tightening of nut (10).
6. Hold the diaphragm so that screw holes in the diaphragm (12)

and powertrol body (21) align. Tighten diaphragm nut (10) with a wrench. At the final tightening release the diaphragm and permit it to rotate approximately 5° to 10°. The diaphragm holes should now be properly aligned with the body holes.

To check for proper alignment proceed as follows:

Rotate diaphragm clockwise and counterclockwise as far as possible. Diaphragm screw holes should rotate equal distance on either side of powertrol body screw holes ±1/8".

Repeat assembly procedure until diaphragm and yoke are properly aligned. There must be no contact between yoke and body nozzle during its normal opening and closing movement. To simulate this movement hold powertrol body and diaphragm holes aligned. Move yoke to open and closed positions. There must be no evidence of contact or dragging.

7. Remove machine screws per step 5.
8. Install spring (9) with spring guide (8) on top of spring.
9. Install cover (5) using eight machine screws (4).
10. Replace adjusting screw (2) and nut (3), then cap (1).

SYMPTOM	PROBABLE CAUSE	REMEDY
Fails to open when pressure lowers	No spring compression	Tighten adjusting screw
	Mineral buildup on yoke extension (17)	Disassemble and clean part, Replace "O" rings (22) and (23).
	Damaged spring	Disassemble and replace.
	Spring guide (8) is not in place	Disassemble and place guide (8) on top of spring (9).
Fails to close when delivery pressure rises	Yoke dragging on inlet nozzle	Disassembled and reassemble use procedure.
	Spring compressed	Back off adjusting screw
	Mineral deposit on yoke extension (17)	Disassemble and clean part. Replace "o" rings (22) and (23).
	Mechanical obstruction	Disassemble and remove obstruction
	Worn disc	Disassemble, remove and replace disc retainer assembly. (16)
Leakage from cover vent hole	Yoke dragging on inlet nozzle	Refer to paragraph 6
	Damaged diaphragm (12)	Disassemble and replace
	Loose diaphragm nut (10)	Remove cover and tighten nut



CRA

REMOTE SENSING TYPE

Pressure Reducing Control

(Bronze Body with 303SS Trim)

When ordering parts specify:

- All nameplate data
- Description
- Item number

Size (inch)	Stock Number	SEAT DIA.	Adjustment Range (PSI)
3/8	7974406G	1/4	2 - 30
3/8	7974403D	1/4	15-75
3/8	7974409A	1/4	20 - 105
3/8	7974404B	1/4	30 - 300
Factory Set Pressure			PSI per Turn*
2 - 30 set @ 10 psi			3.0
15 - 75 set @ 20 psi			9.0
20 - 105 set @ 20 psi			12.0
30 - 300 set @ 60 psi			27.0

*Approximate-Final Adjustment should be with a pressure gauge and with flow.

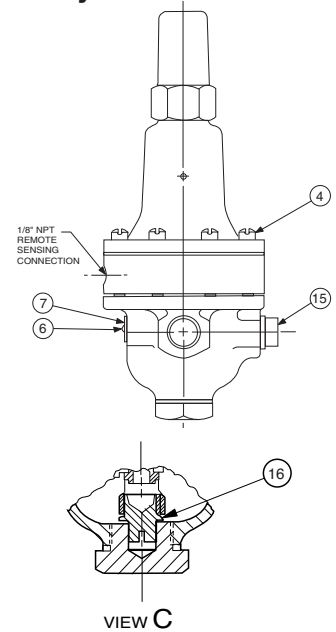
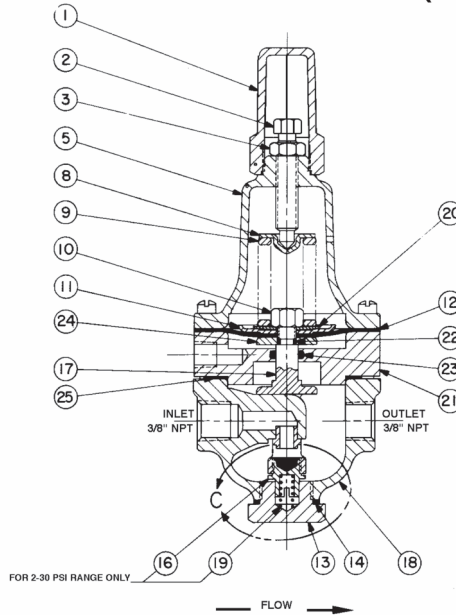

Item	Description	Material	Part Number	List Price
1	Cap	PL	67628J	
2	Adjusting Screw	BRS	7188201D	
3	Jam Nut (3/8-16)	303	6780106J	
4*	Machine Screw 10-32x1-1/4"(Fil.Hd.) 8 Req'd	SS	6757874A	
5	Cover	BRS	C2544K	
6	Nameplate Screw	SS	67999D	
7	Nameplate	BRS	C0022001G	
8	Spring Guide	302	71881H	
9	Spring (15-75 psi)	CHR/VAN	71884B	
	Spring (30-300 psi)	CHR/VAN	71885B	
	Spring (2 - 30 psi)	SS	81594E	
10	Hex Nut 5/16 - 18	303	71883D	
11	Diaphragm Washer (upper)	302	71891G	
12*	Diaphragm	NBR	C6936D	
13	Plug, Body	BRS	V5653A	
14*	Gasket	Fiber	40174F	
15	Plug, 3/8 NPT	BRS	6766003F	
16*	Disc Retainer Assy. (2 - 30 psi)	SS/Rub	C8348K	
	Disc Retainer Assy. (15 - 75 psi)	SS/Rub	37133G	
	Disc Retainer Assy. (20 - 105 psi)	SS/Rub	37133G	
	Disc Retainer Assy. (30 - 300 psi)	SS/Rub	37133G	
17	Yoke	VBZ	C1799A	
18	Body & Seat Assy, 1/4" Seat	BR/SS	8339701J	
19*	Bucking Spring (Required with 2 - 30psi)	302	V05586	
20	Belleville Washer	STL	7055007E	
21	Powertrol Body	BRS	C3388A	
22*	O-Ring	NBR	00708J	
23*	O-Ring	NBR	00746J	
24	Diaphragm Washer (lower)	BRS	C1804J	
25	Gasket	NBR	8059401D	
*	Repair Kit (No Bucking Spring)	Buna®-N	20153404F	
*	Repair Kit (with Bucking Spring)	Buna®-N	9170001D	