

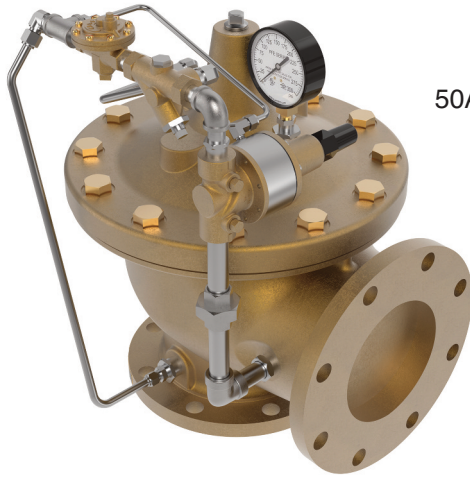

— MODEL — **50-20**

Seawater Service Pressure Relief Valve



50A-20 (Angle)

- **Fast Opening to Maintain Steady Line Pressure**
- **Accommodates Wide Range of Flow Rates**
- **Closes Gradually for Surge-Free Operation**
- **Adjustable Pressure Settings, Not Affected by Pressure At Valve Discharge**

The Cla-Val Model 50-20 Seawater Service Pressure Relief Valve is designed specifically to automatically relieve excess pressure in fire protection pumping systems. Pilot controlled, it maintains constant system pressure at the pump discharge within very close limits as demands change.

Schematic Diagram

Item Description

- | | |
|---|------------------------------|
| 1 | 100S/2100S Hytrol Main Valve |
| 2 | CRL Pressure Relief Control |
| 3 | X44A Strainer & Orifice Assy |
| 4 | 81-01 Check Valve |

Optional Features

Item Description

- | | |
|---|---------------------------|
| B | CK2 Isolation Valves |
| C | CV Flow Control (Closing) |
| F | Remote Pilot Sensing |
| H | Drain to Atmosphere |
| S | CV Flow Control (Opening) |

Please note that if the Model 50-20 is to be used on a continuous duty basis to maintain fire-system pressure, suitable back pressure must be provided on the valve to prevent cavitation damage. Consult the factory for details.

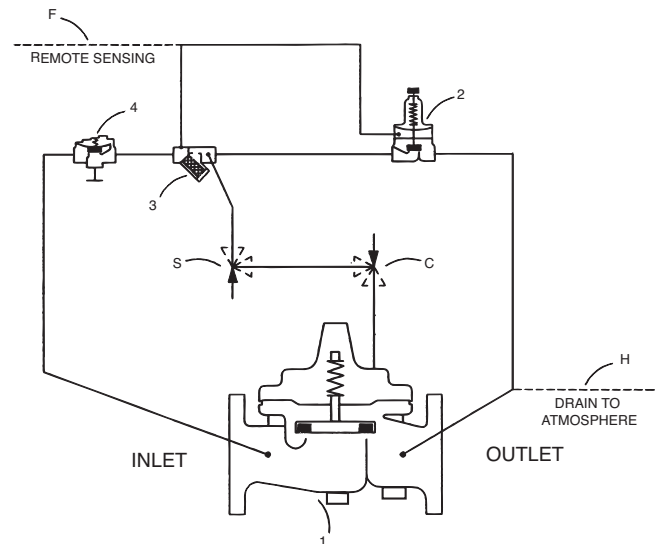

Specification

Sizes: Threaded Ends: 1 1/2" - 3"
Globe Flanged: 2" - 36"
Angle Flanged: 2" - 16"

End Details: Cast Steel ANSI B16.5
Bronze ANSI B16.24
Stainless Steel ANSI B16.5
Ductile Iron ANSI B16.42

Pressure 150 Class 250 psi Max.
Ratings: 300 Class 400 psi Max.

Temperature

Range: Water 180°F Max.

Materials: **Main valve body & cover**
Ductile Iron ASTM A-536*
Cast Steel ASTM A216-WCB*
Naval Bronze ASTM B61
Stainless Steel ASTM A743-CF-8M
Ni. AL. Bronze ASTM B148
Super Duplex SST

Main valve trim:

ASTM B61 Bronze Seat,
Monel Trim

Pilot control system:

Cast Bronze with Monel Trim
Monel, Super Duplex Stainless Steel optional
Stainless Steel 316 Tubing & Fittings

Adjustment 20 - 200 psi (150 class)
Ranges: 100 - 300 psi (300 class)

*The 50G-20 (globe) and 50A-20 (angle) in cast steel are supplied with standard internal and external epoxy coating

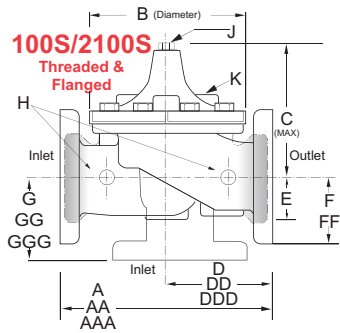

Model 50-20 Dimensions

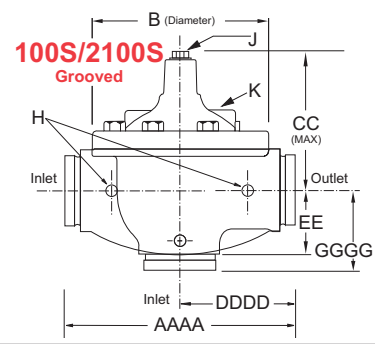

Valve Size (Inches)	1	1 1/4	1 1/2	2	2 1/2	3	4	6	8	10	12	14	16	18	20	24	30	36
A Threaded	7.25	7.25	7.25	9.38	11.00	12.50	—	—	—	—	—	—	—	—	—	—	—	—
AA 150 ANSI	—	—	8.50	9.38	11.00	12.00	15.00	20.00	25.38	29.75	34.00	39.00	41.38	46.00	52.00	61.50	63.00	76.00
AAA 300 ANSI	—	—	9.00	10.00	11.62	13.25	15.62	21.00	26.38	31.12	35.50	40.50	43.50	47.64	53.62	63.24	64.50	76.00
AAAA Grooved End	—	—	8.50	9.00	11.00	12.50	15.00	20.00	25.38	—	—	—	—	—	—	—	—	—
B Dia.	5.62	5.62	5.62	6.62	8.00	9.12	11.50	15.75	20.00	23.62	28.00	32.75	35.50	41.50	45.00	53.16	56.00	66.00
C Max.	5.50	5.50	5.50	6.50	7.56	8.19	10.62	13.38	16.00	17.12	20.88	24.19	25.00	39.06	41.90	43.93	54.60	61.50
CC Max. Grooved End	—	—	4.75	5.75	6.88	7.25	9.31	12.12	14.62	—	—	—	—	—	—	—	—	—
D Threaded	3.25	3.25	3.25	4.75	5.50	6.25	—	—	—	—	—	—	—	—	—	—	—	—
DD 150 ANSI	—	—	4.00	4.75	5.50	6.00	7.50	10.00	12.69	14.88	17.00	19.50	20.81	—	—	30.75	—	—
DDD 300 ANSI	—	—	4.25	5.00	5.88	6.38	7.88	10.50	13.25	15.56	17.75	20.25	21.62	—	—	31.62	—	—
DDDD Grooved End	—	—	4.75	—	6.00	7.50	—	—	—	—	—	—	—	—	—	—	—	—
E	1.12	1.12	1.12	1.50	1.69	2.06	3.19	4.31	5.31	9.25	10.75	12.62	15.50	12.95	15.00	17.75	21.31	24.56
EE Grooved End	—	—	2.00	2.50	2.88	3.12	4.25	6.00	7.56	—	—	—	—	—	—	—	—	—
F 150 ANSI	—	—	2.50	3.00	3.50	3.75	4.50	5.50	6.75	8.00	9.50	10.50	11.75	15.00	16.50	19.25	22.50	25.60
FF 300 ANSI	—	—	3.06	3.25	3.75	4.13	5.00	6.25	7.50	8.75	10.25	11.50	12.75	15.00	16.50	19.25	24.00	25.60
G Threaded	1.88	1.88	1.88	3.25	4.00	4.50	—	—	—	—	—	—	—	—	—	—	—	—
GG 150 ANSI	—	—	4.00	3.25	4.00	4.00	5.00	6.00	8.00	8.62	13.75	14.88	15.69	—	—	22.06	—	—
GGG 300 ANSI	—	—	4.25	3.50	4.31	4.38	5.31	6.50	8.50	9.31	14.50	15.62	16.50	—	—	22.90	—	—
GGGG Grooved End	—	—	3.25	—	4.25	5.00	—	—	—	—	—	—	—	—	—	—	—	—
H NPT Body Tapping	.375	.375	.375	.375	.50	.50	.75	.75	1	1	1	1	1	1	1	1	2	2
J NPT Cover Center Plug	.25	.25	.25	.50	.50	.50	.75	.75	1	1	1.25	1.5	2	1.5	1.5	1.5	2	2
K NPT Cover Tapping	.375	.375	.375	.375	.50	.50	.75	.75	1	1	1	1	1	1	1	1	2	2
Stem Travel	0.4	0.4	0.4	0.6	0.7	0.8	1.1	1.7	2.3	2.8	3.4	4.0	4.5	5.1	5.63	6.75	7.5	8.5
Approx. Ship Wt. Lbs.	15	15	15	35	50	70	140	285	500	780	1165	1600	2265	2982	3900	6200	7703	11720

Valve Size (mm)	25	32	40	50	65	80	100	150	200	250	300	350	400	450	500	600	750	900
A Threaded	184	184	184	238	279	318	—	—	—	—	—	—	—	—	—	—	—	—
AA 150 ANSI	—	—	216	238	279	305	381	508	645	756	864	991	1051	1168	1321	1562	1600	1930
AAA 300 ANSI	—	—	229	254	295	337	397	533	670	790	902	1029	1105	1210	1362	1606	1638	1930
AAAA Grooved End	—	—	216	228	279	318	381	508	645	—	—	—	—	—	—	—	—	—
B Dia.	143	143	143	168	203	232	292	400	508	600	711	832	902	1054	1143	1350	1422	1676
C Max.	140	140	140	165	192	208	270	340	406	435	530	614	635	992	1064	1116	1387	1562
CC Max. Grooved End	—	—	120	120	146	175	184	236	308	371	—	—	—	—	—	—	—	—
D Threaded	83	83	83	121	140	159	—	—	—	—	—	—	—	—	—	—	—	—
DD 150 ANSI	—	—	102	121	140	152	191	254	322	378	432	495	528	—	—	781	—	—
DDD 300 ANSI	—	—	108	127	149	162	200	267	337	395	451	514	549	—	—	803	—	—
DDDD Grooved End	—	—	—	121	—	152	191	—	—	—	—	—	—	—	—	—	—	—
E	29	29	29	38	43	52	81	110	135	235	273	321	394	329	381	451	541	624
EE Grooved End	—	—	52	64	73	79	108	152	192	—	—	—	—	—	—	—	—	—
F 150 ANSI	—	—	64	76	89	95	114	140	171	203	241	267	298	381	419	489	572	650
FF 300 ANSI	—	—	78	83	95	105	127	159	191	222	260	292	324	381	419	489	610	650
G Threaded	48	48	48	83	102	114	—	—	—	—	—	—	—	—	—	—	—	—
GG 150 ANSI	—	—	102	83	102	102	127	152	203	219	349	378	399	—	—	560	—	—
GGG 300 ANSI	—	—	102	89	110	111	135	165	216	236	368	397	419	—	—	582	—	—
GGGG Grooved End	—	—	—	83	—	108	127	—	—	—	—	—	—	—	—	—	—	—
H NPT Body Tapping	.375	.375	.375	.375	.50	.50	.75	.75	1	1	1	1	1	1	1	1	2	2
J NPT Cover Center Plug	.25	.25	.25	.50	.50	.50	.75	.75	1	1	1.25	1.5	2	1.5	1.5	1.5	2	2
K NPT Cover Tapping	.375	.375	.375	.375	.50	.50	.75	.75	1	1	1	1	1	1	1	1	2	2
Stem Travel	10	10	10	15	18	20	28	43	58	71	86	102	114	130	143	171	190	216
Approx. Ship Wt. Kgs.	7	7	7	16	23	32	64	129	227	354	528	726	1027	1353	1769	2812	3494	5316

Valve Capacity

Valve Size (inches)	1	1 1/4	1 1/2	2	2 1/2	3	4	6	8	10	12	14	16	18	20	24	30	36
Max. Continuous GPM	55	93	125	210	300	460	800	1800	3100	4900	7000	8400	11000	14000	17000	25000	42000	50000
Max Surge GPM	120	210	280	470	670	1000	1800	4000	7000	11000	16000	19000	25000	31000	39000	56500	63000	85000

Purchase Specifications

The Fire Pump Pressure Relief Valve shall modulate to relieve excess pressure in a fire protection system. It shall maintain constant pressure in the system regardless of demand changes. It shall be pilot controlled and back pressure shall not affect its set point. It shall be actuated by line pressure through a pilot control system and open fast in order to maintain steady system pressure as system demand decreases. It shall close gradually to control surges and shall re-seat drip-tight within 5% of its pressure setting. The main valve shall be of the hydraulically-operated, pilot-controlled, diaphragm-type, globe or angle valve. It shall have a single, removable, teflon-coated seat. Internal and exter-

We recommend providing adequate space around valve for maintenance work.

nal epoxy coating, a stem guided at both ends, and a resilient disc with a rectangular cross section, being contained on 3 1/2 sides. No external packing glands shall be permitted and the diaphragm shall not be used as a seating surface. The pilot control shall be a direct-acting, adjustable, spring-loaded, diaphragm-type valve designed for modulating service to permit flow when controlling pressure exceeds spring setting. It shall be the MODEL 50G-20 (globe) or Model 50A-20 (angle) Pressure Relief Valve as manufactured by Cla-Val, Newport Beach, California.