

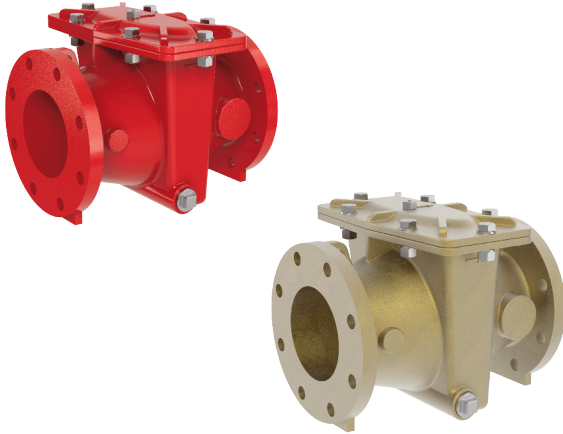

—MODEL— **X43HL**

Cla-Val Model X43HL Strainer



Now available up to
48-inches/1200 mm

- Low Pressure Drop
- Ductile Iron Fusion Bonded Epoxy Coated construction with a 316 Stainless Steel Strainer
- Also available: Nickel Aluminum Bronze Construction with a Titanium Strainer
- Large Flow Area H-Style Design
- Service Without Removal From Line

The durable Cla-Val Model X43HL Strainer is the easiest and most cost effective way to protect piping and equipment from damage caused by pipeline debris. Its large flow area and durable materials of construction means it can withstand the harsh conditions often encountered in refinery and offshore applications. The body port allows for installation of a manual flush valve to clear small amounts of debris from the strainer without removing the cover. For more thorough cleaning, the top cover can easily be removed without taking strainer out of the pipeline. The strainer may be installed in any position, however, installation with cover up is recommended

Model X43HL Strainer Typical Application

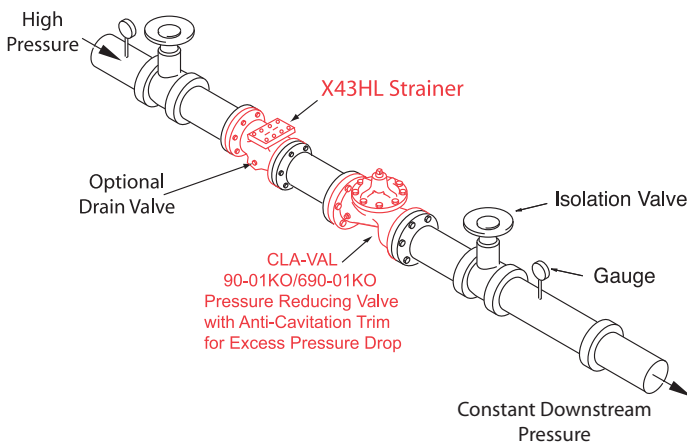

Model X43HL Flow Chart

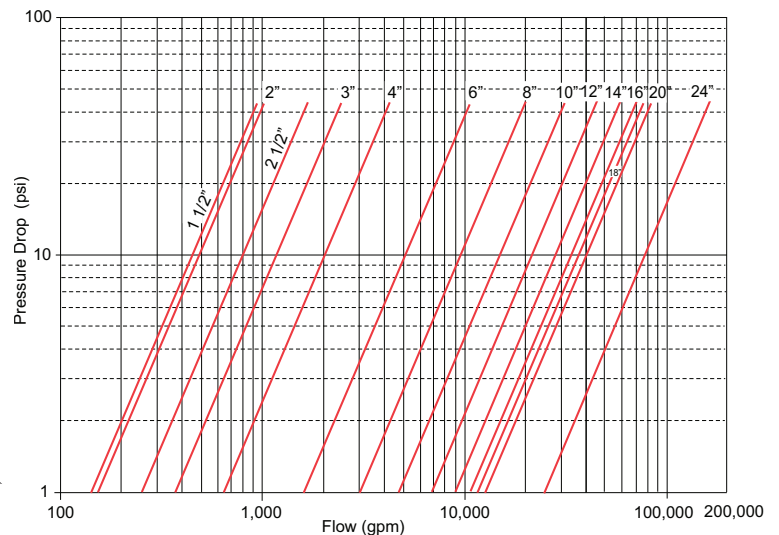

Please consult factory to confirm flow data for strainers larger than 24-inch.

C_v Factor

Strainer Size (inches)	1 1/2	2	2 1/2	3	4	6	8	10	12	14	16	18	20	24
C _v (Gal/Min. - gpm.)	96	150	254	367	654	1644	3922	4566	6800	8949	11692	12796	18264	26302
C _v (Litres/Sec - l/s.)	23	36	61	85	157	395	702	1097	1580	2150	2809	3555	4388	6319

C_v in gpm = gpm @ 1psid head loss • C_v in l/s = l/s @ 1bar head loss

Specifications

Sizes (Inches):	1½, 2, 2½, 3, 4, 6, 8, 10, 12, 14, 16, 18, 20, 24, 36 and 48
Sizes (mm):	40, 50, 65, 80, 100, 150, 200, 250, 300, 350, 400, 450, 500, 600, 900 and 1200
Ends:	Flanged, ANSI Class 150 and 300 (Note: 300# Flanges are Raised Face)
Max Pressure Rating:	150 - 250 psi • 300 - 400 psi
Fluids:	Compatible with Materials of Construction
Temperature:	Maximum 180°F
Materials:	
Body & Cover:	Ductile Iron ANSI B16.62; Fusion Bonded Epoxy Coating Standard or NiAlBrz ASTM B148
Cover Seal:	Buna-N® Synthetic Rubber
Strainer:	316 Stainless Steel; Ductile Iron, Epoxy Coated Frame or in Titanium on a NiAlBrz Frame
Strainer Mesh Sizes:	Standard 10 mesh / 2000 Micron / Openings 0.078 inch Optional .039 and .059 inch openings available
Drain/Blow-Off Connection:	Furnished with Plug as Standard.
Bolts:	SS 303 or Titanium

Please consult factory to confirm dimensional data for larger sizes

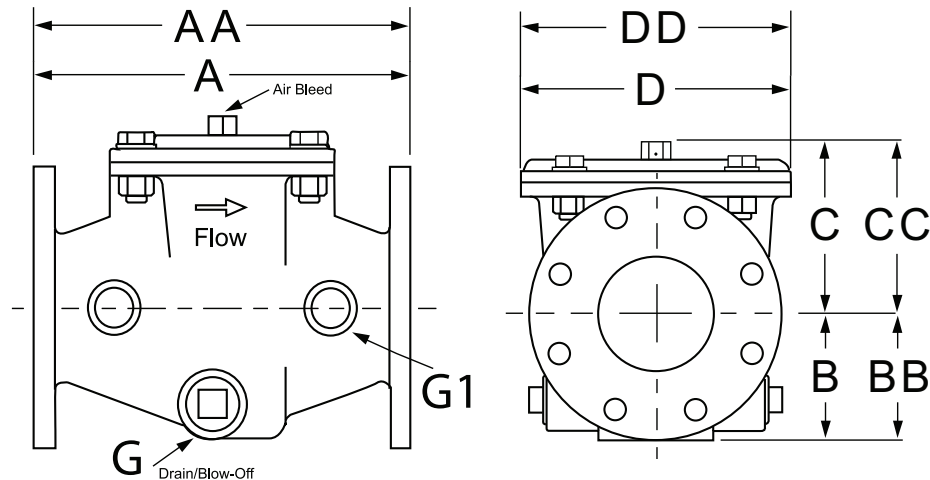

Dimensions

Strainer Size (inches)	1 ½	2	2 ½	3	4	6	8	10	12	14	16	18	20	24
A 150 ANSI	9.06	9.06	9.06	11.81	11.81	15.75	19.69	22.83	24.02	25.59	31.50	31.50	37.40	43.31
AA 300 ANSI	9.13	9.13	9.13	11.89	11.89	15.83	19.76	22.91	24.09	25.67	31.57	31.57	37.48	43.39
B 150 ANSI	3.26	3.26	3.66	4.06	4.33	5.63	6.69	8.86	8.88	10.24	12.20	13.18	19.09	19.09
BB 300 ANSI	3.26	3.26	3.66	4.06	4.33	5.63	6.69	8.86	9.56	10.94	12.20	13.18	19.09	19.09
C Max. 150 ANSI	3.78	3.78	3.78	5.91	5.91	7.52	8.82	11.61	15.16	14.96	19.69	19.69	23.98	23.98
CC Max. 300 ANSI	5.20	5.20	5.35	6.22	6.22	7.99	9.33	12.79	15.67	15.67	19.69	19.69	23.98	23.98
D Dia. 150 ANSI	7.87	7.87	7.87	9.25	9.25	15.74	18.11	22.05	26.77	26.77	35.43	35.43	46.85	46.85
DD Dia. 300 ANSI	7.99	7.99	7.99	9.37	9.37	15.86	18.23	22.17	26.85	26.85	35.43	35.43	46.85	46.85
G Drain/Blow-off Plug	1¼	1¼	1¼	1¼	1¼	1¼	1¼	1¼	2	2	2	2	3	3
Approx. Ship Wt. Lbs.	33	36	39	59	73	143	212	432	626	683	970	1073	1175	1962

Strainer Size (mm)	40	50	65	80	100	150	200	250	300	350	400	450	500	600
A 150 ANSI	230	230	230	300	300	400	500	580	610	650	800	800	950	1100
AA 300 ANSI	232	232	232	302	302	402	502	582	612	652	802	802	952	1102
B 150 ANSI	83	83	93	103	110	143	170	225	228	260	310	335	485	485
BB 300 ANSI	83	83	93	103	110	143	170	225	243	278	310	335	485	486
C Max. 150 ANSI	96	96	96	150	150	191	224	295	385	380	500	500	609	609
CC Max. 300 ANSI	132	132	136	158	158	203	237	325	398	398	500	500	609	609
D Dia. 150 ANSI	200	200	200	235	235	400	460	560	680	680	900	900	1190	1190
DD Dia. 300 ANSI	203	203	203	238	238	403	463	563	682	682	900	900	1190	1190
G Drain/Blow-off Plug	1¼	1¼	1¼	1¼	1¼	1¼	1¼	1¼	2	2	2	2	3	3
Approx. Ship Wt. (kg)	15	16	18	27	33	65	96	196	284	310	440	600	810	890