

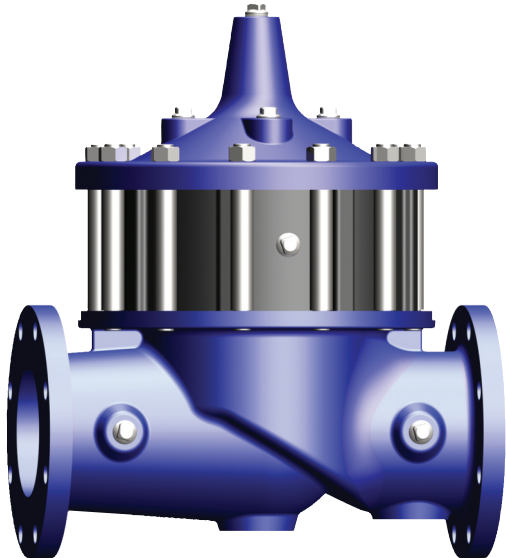

— MODEL — **100-02KO**

Powertrol Valve



- **Virtually Cavitation Free Operation**
- **Severe Service Design - High Pressure Differentials**
- **Reduced Noise and Vibration**
- **316 Stainless Steel Disc Guide and Seat Standard**
- **Drip-Tight, Positive Sealing**
- **Service Without Removal From Line**
- **Retrofit to Standard Hytrol Valves**

The Cla-Val Model 100-02KO Anti-Cavitation Powertrol Valve is designed for applications where there is a high potential for damage from cavitation. Specify this valve series for a wide variety of control valve applications having pressure differentials up to 300 psid or for relief valves having atmospheric discharge up to 150 psid.

The 100-02KO Powertrol main valve provides optimum internal pressure control through a unique anti-cavitation trim design. Constructed of 316 Stainless Steel, the seat and disc guide trim components feature dual interlocked sleeves containing radial slots that deflect internal flow to impinge upon itself in the center of the flow path, harmlessly dissipating the potential cavitation damage. This unique design also lessens the possibility of fouling if large particles in the water are present due to the large flow path of the radial slots.

The 100-02KO Powertrol is the basic valve used in Cla-Val Automatic Control Valves is recommended where independent operating pressure is desired for high differential applications requiring remote control, pressure regulation, solenoid operation, rate of flow control, or liquid level control.

The Anti-Cavitation Trim components can be retrofitted to existing valves if the application indicates an appropriate need. Please consult factory for details.

Principle of Operation

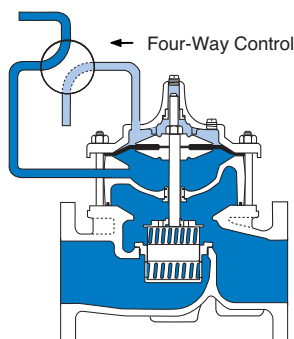

Full Open Operation

When operating pressure below the diaphragm is applied and operating pressure is relieved from the cover chamber and, the valve is held open, allowing full flow.

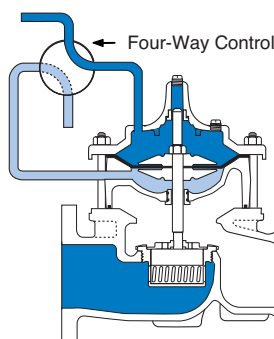

Tight Closing Operation

When pressure below the diaphragm is relieved and operating pressure is applied to the cover chamber, the valve closes drip-tight.

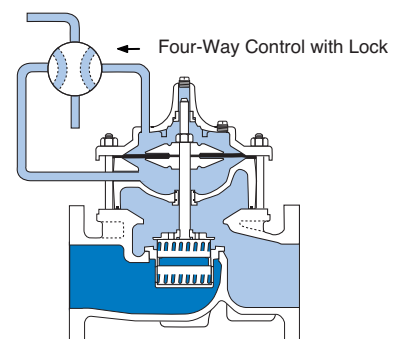

Modulating Action

The valve holds any intermediate position when operating pressure is equal above and below the diaphragm. A Cla-Val four-way pilot control with "lock" position can maintain this balance by stopping flow in the pilot control system.

100-02KO Main Valve Specifications

Available Sizes

Pattern	Globe	Angle	Grooved End
Size (mm)	80 - 600 mm	80 - 400 & 600 mm	80 - 200 mm

Pressure Ratings (Recommended Maximum Pressure - psi)

Valve Body & Cover		Pressure Class			
		Flanged			Threaded
Grade	Material	ANSI Standards*	150 Class	300† Class	End‡ Details
ASTM A536	Ductile Iron	B16.42	250	400	400
ASTM A216-WCB	Cast Steel	B16.5	285	400	400
UNS 87850	Bronze	B16.24	225	400	400

Note: * ANSI standards are for flange dimensions only.
 Flanged valves are available faced but not drilled.
 ‡ End Details machined to ANSI B2.1 specifications.
 † Consult factory when Maximum Operating Pressure Differential (MOPD) is greater than 400 PSID
“Valves for higher pressure are available; consult factory for details”

Materials

Component	Standard Material Combinations		
Body & Cover	Ductile Iron	Cast Steel	Bronze
Available Sizes (mm)	80 - 600 mm	80 - 400 mm	80 - 400 mm
Disc Retainer & Diaphragm Washer	Cast Iron	Cast Steel	Bronze
Trim: Disc Guide, Seat & Cover Bearing	Stainless Steel is Standard		
Disc	Buna-N® Rubber		
Diaphragm	Nylon Reinforced Buna-N® Rubber		
Stem, Nut & Spring	Stainless Steel		
For material options not listed consult factory. Cla-Val manufactures valves in more than 50 different alloys.			

Operating Temp. Range

Fluids
-40° to 82° C

Options

Epoxy Coating - suffix KC

The NF/ANSI 61 fusion bonded epoxy coating option is for use with cast iron, ductile iron or steel valves. This coating is resistant to various water conditions, certain acids, chemicals, solvents and alkalis. epoxy coatings are applied in accordance with AWWA coating specifications C116-03. Do not use with temperatures above 80° C.

Viton® Rubber Parts - suffix KB

Optional diaphragm, disc and o-ring fabricated with Viton® synthetic rubber. Viton® is well suited for use with mineral acids, salt solutions, chlorinated hydrocarbons, and petroleum oils; and is primarily used in high temperature applications up to 120° C. Do not use with epoxy coating above 80° c.

Heavy Spring - suffix KH

The heavy spring option is used in applications where there is low differential pressure across the valve, and the additional spring force is needed to help the valve close. The option is best suited for valves used in on-off (non-modulating) service.

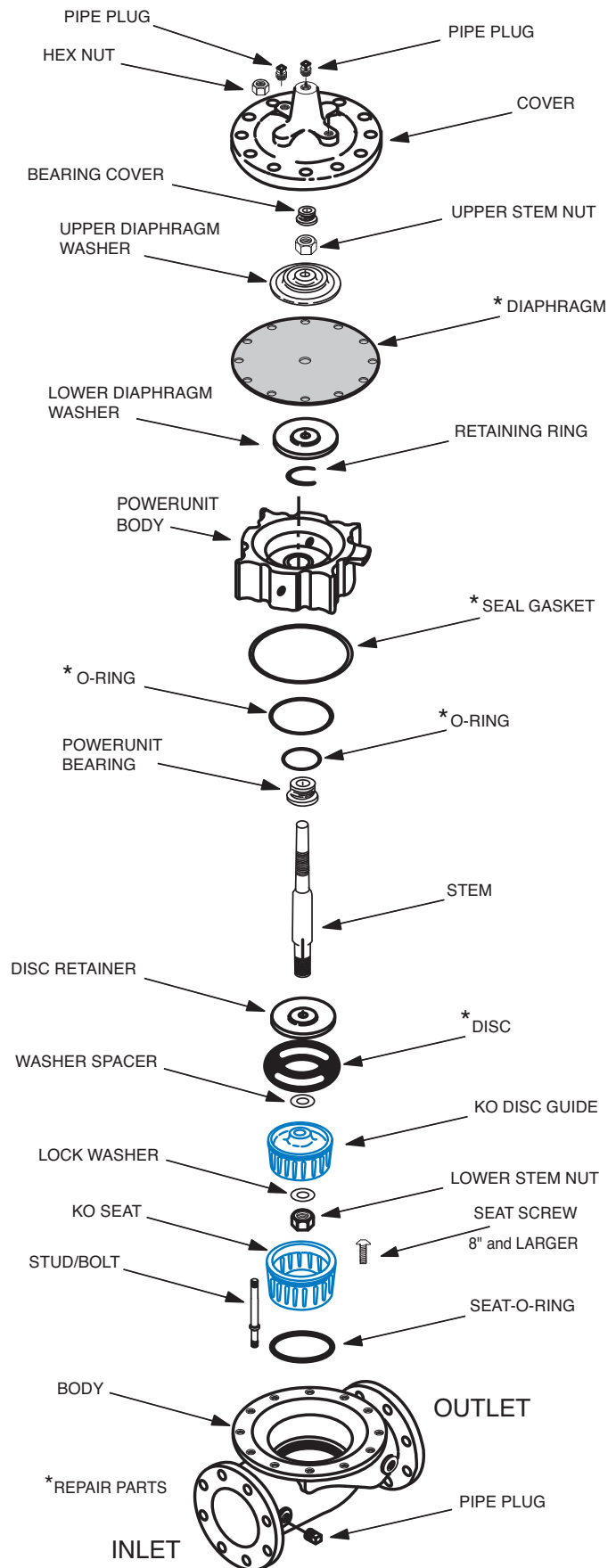

For assistance in selecting appropriate valve options or valves manufactured with special design requirements, please contact our Regional Sales Office or Factory.

100-02KO Main Valve Functional Data

Valve Size		Inches	3	4	6	8	10	12	14	16	18	20	24
		mm.	80	100	150	200	250	300	350	400	450	500	600
C_V Factor	Globe Pattern	Gal./Min. (gpm.)	52	90	218	362	602	900	1100	1200	1550	1950	3900
		Litres/Sec. (l/s.)	12.5	21.6	52	87	159	194	264	288	360	469	938
	Angle Pattern	Gal./Min. (gpm.)	55	95	232	388	479	790	1075	1175	—	—	3775
		Litres/Sec. (l/s.)	13.2	22.8	56	93	115	190	258	282	—	—	906
Equivalent Length of Pipe	Globe Pattern	Feet (ft.)	416	572	858	1315	2444	2118	1937	3022	3537	4199	4532
		Meters (m.)	127	174	262	401	745	646	590	921	1078	1280	1381
	Angle Pattern	Feet (ft.)	372	514	757	1145	2133	2226	2021	3152	—	—	2583
		Meters (m.)	113	157	231	349	650	678	616	961	—	—	787
K Factor	Globe Pattern		29.3	29.0	25.5	27.7	41.0	27.7	22.8	31.4	30.2	29.5	15.4
	Angle Pattern		26.2	26.0	22.5	24.1	35.8	29.1	23.8	32.8	—	—	16.4
Liquid Displaced from Cover Chamber When Valve Opens		U.S. Gal.	.08	.17	.53	1.26	2.5	4.0	6.5	9.6	11	12	29
		Litres	.30	.64	2.0	4.8	9.5	15.1	25.6	36.2	41.6	45.4	110

C_V Factor

Formulas for computing C_V Factor, Flow (Q) and Pressure Drop (ΔP):

$$C_V = \frac{Q}{\sqrt{\Delta P}} \quad Q = C_V \sqrt{\Delta P} \quad \Delta P = \left(\frac{Q}{C_V} \right)^2$$

K Factor (Resistance Coefficient)

The Value of K is calculated from the formula: $K = \frac{894d^4}{C_V^2}$
(U.S. system units)

Equivalent Length of Pipe

Equivalent lengths of pipe (L) are determined from the formula: $L = \frac{Kd}{12f}$
(U.S. system units)

Fluid Velocity

Fluid velocity can be calculated from the following formula: $V = \frac{.4085 Q}{d^2}$
(U.S. system units)

Where:

C_V = U.S. (gpm) @ 1 psi differential at 60° F water
or

= (l/s) @ 1 bar (14.5 PSIG) differential
at 15° C water

d = inside pipe diameter of Schedule 40 Steel Pipe (inches)

f = friction factor for clean, new Schedule 40 pipe
(dimensionless) (from Cameron Hydraulic Data,
18th Edition, P 3-119)

K = Resistance Coefficient (calculated)

L = Equivalent Length of Pipe (feet)

Q = Flow Rate in U.S. (gpm) or (l/s)

V = Fluid Velocity (feet per second) or (meters per second)

ΔP = Pressure Drop in (psi) or (bar)

Model 100-02KO Flow Chart (Based on normal flow through a wide open valve)

SOLID LINE IS FULL OPEN FLOW CURVES FOR 18 FT/SEC CONTINUOUS DUTY APPLICATIONS
DASHED LINE IS FULL OPEN FLOW CURVE FOR 25 FT/SEC INTERMITTENT DUTY APPLICATIONS

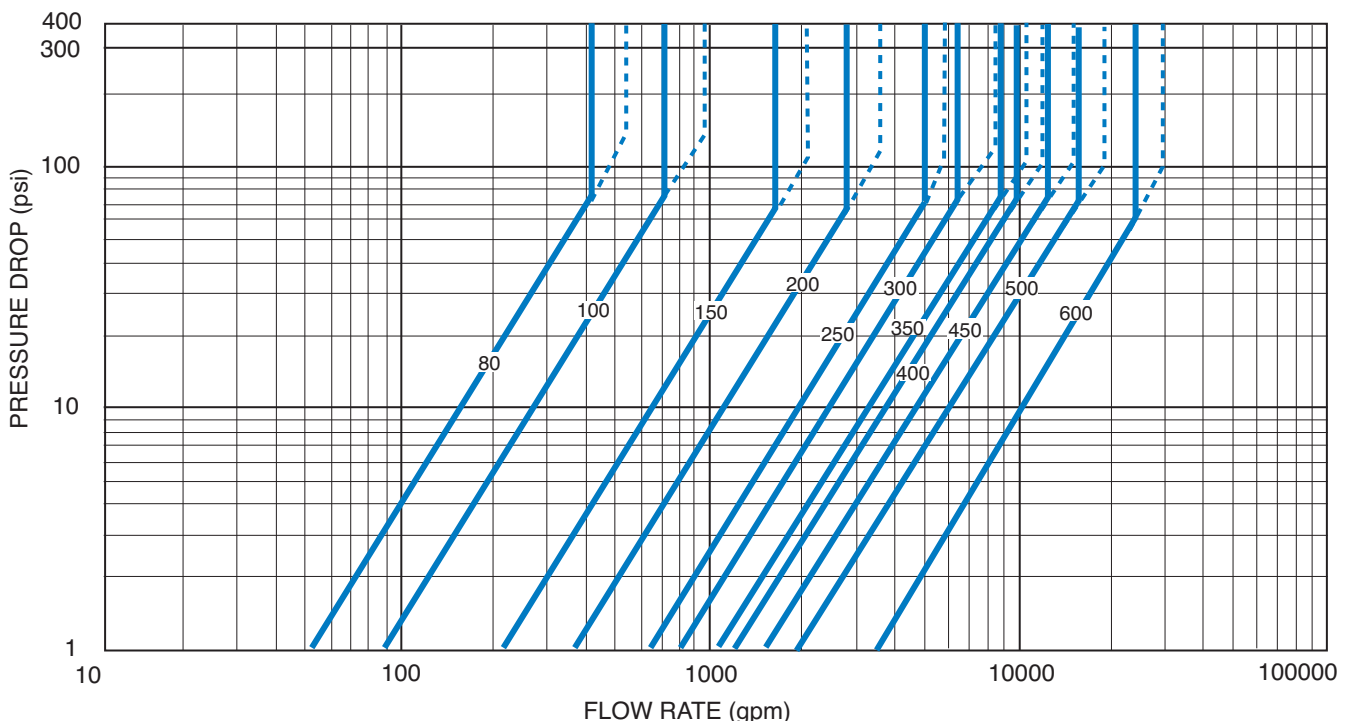

100-02KO Main Valve Dimensions

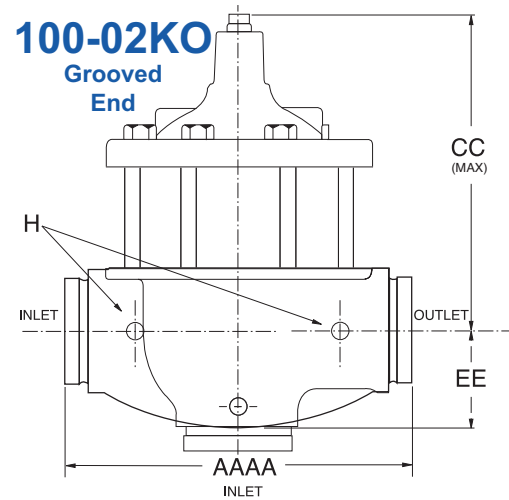
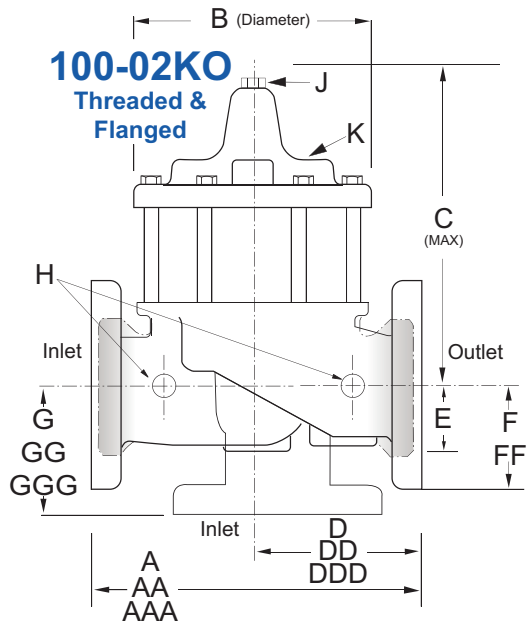

Valve Size (mm)	80	100	150	200	250	300	350	400	450	500	600
A Threaded	318	—	—	—	—	—	—	—	—	—	—
AA 150 ANSI	305	381	508	645	756	864	991	1051	1168	1321	1562
AAA 300 ANSI	337	397	533	670	790	902	1029	1105	1210	1326	1606
AAAA Grooved End	318	381	508	645	—	—	—	—	—	—	—
B Diameter	232	292	400	508	600	711	832	902	1054	1143	1350
C Maximum	284	362	468	554	594	744	816	889	1255	1348	1435
CC Maximum Grooved End	245	260	343	436	—	—	—	—	—	—	—
D Threaded	159	—	—	—	—	—	—	—	—	—	—
DD 150 ANSI	152	191	254	322	378	432	495	528	—	—	—
DDD 300 ANSI	162	200	267	337	395	451	514	549	—	—	—
DDDD Grooved End	152	191	—	—	—	—	—	—	—	—	—
E	52	81	110	135	235	273	321	394	329	381	451
EE Grooved End	79	108	152	192	—	—	—	—	—	—	—
F 150 ANSI	95	114	140	171	203	241	267	298	381	419	489
FF 300 ANSI	105	127	159	191	222	260	292	324	381	419	489
G Threaded	114	—	—	—	—	—	—	—	—	—	—
GG 150 ANSI	102	127	152	203	219	349	378	399	—	—	—
GGG 300 ANSI	111	135	165	216	236	368	397	419	—	—	—
GGGG Grooved End	108	127	—	—	—	—	—	—	—	—	—
H NPT Body Tapping	0.50	0.75	0.75	1.00	1.00	1.00	1.00	1.00	1.00	1.00	1.00
J NPT Cover Center Plug	0.50	0.75	0.75	1.00	1.00	1.25	1.50	2.00	—	—	—
K NPT Cover Tapping	0.50	0.75	0.75	1.00	1.00	1.00	1.00	1.00	1.00	1.00	1.00
Valve Stem Int. Thread UNF	1/4-28	1/4-28	3/8-24	3/8-24	3/8-24	3/8-24	3/8-24	1/2-20	3/4-16	3/4-16	3/4-16
Stem Travel	20	28	43	58	71	86	102	114	130	143	171
Approx. Ship Weight (kgs)	43	86	145	295	426	760	1116	1406	1950	2449	3696

Cla-Val Control Valves operate with maximum efficiency when mounted in horizontal piping with the main valve cover UP, however, other positions are acceptable. Due to component size and weight of 200 mm and larger valves, installation with cover UP is advisable. We recommend isolation valves be installed on inlet and outlet for maintenance. Adequate space above and around the valve for service personnel should be considered essential. A regular maintenance program should be established based on the specific application data. However, we recommend a thorough inspection be done at least once a year. Consult factory for specific recommendations.