

WATER HAMMER PROBLEMS IN YOUR RISER MAINS?

If you're having issues with your water hammer causing damage, Cla-Val has a solution.

The Problem: Water Hammer, at Pump Startup, Causing Damage

- 1 Water line riser pressure is pressurized
- 2 Water is drawn off, and the level in the line drops
- 3 A vacuum is created above the water line, straining pipes and fittings
- 4 When the pump starts, the system is re-pressurized
- 5 The vacuum pressure draws water up the rise, and the pressure spike can cause bursts and leaks

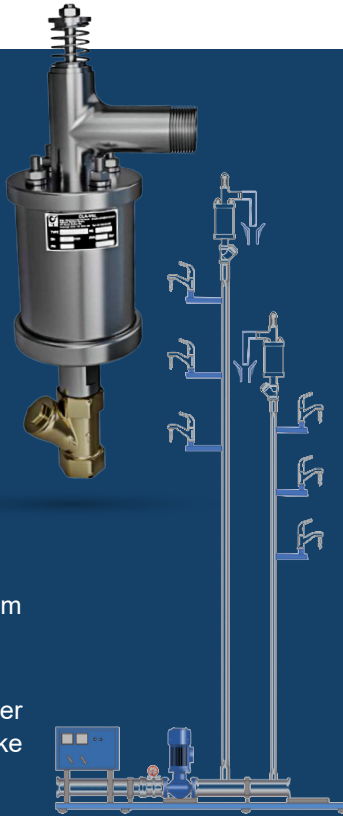

The Solution: Cla-Val's Model 39-SA Surge Arrestor & Air Release Valve

- 1 As the water level drops, air is drawn into the riser
- 2 This prevents a vacuum from forming
- 3 When the pump starts and the system is re-pressurized, air is released at a controlled rate
- 4 This stops dangerous surges, and pressurized air is released during normal operation

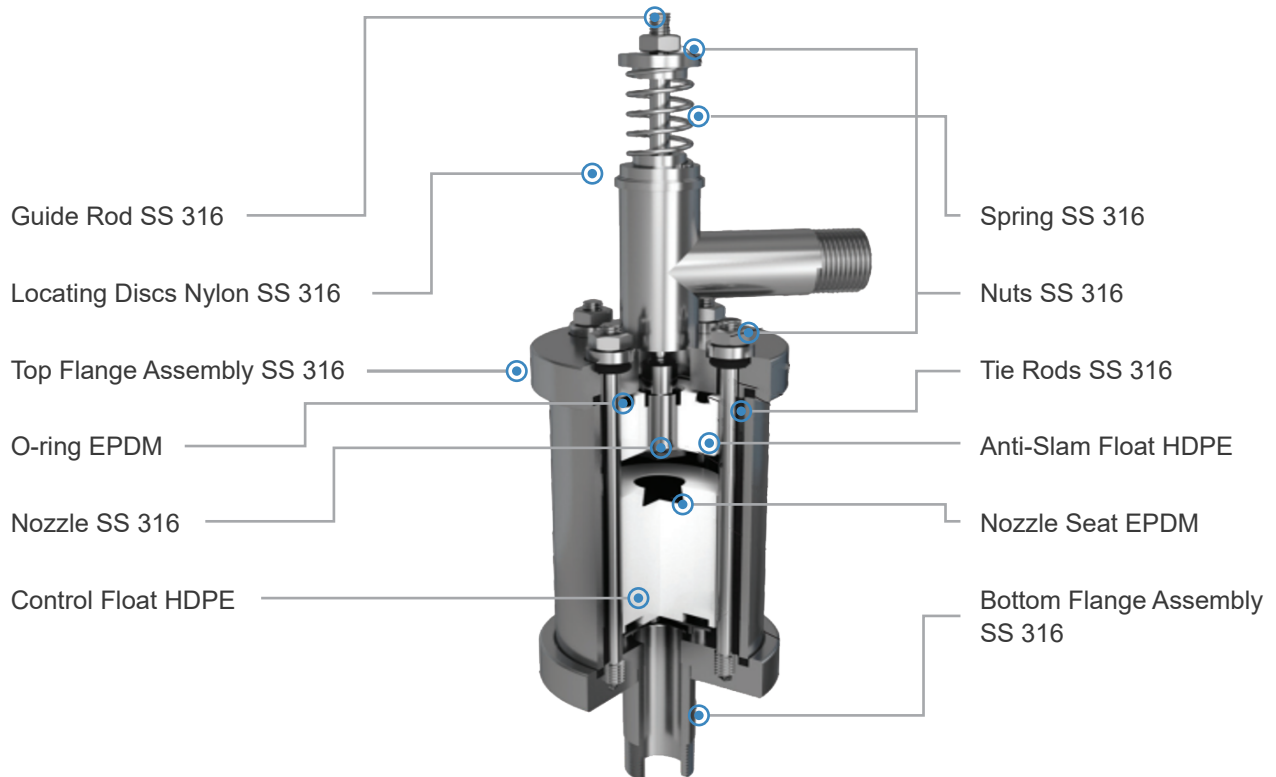

Contact your local Cla-Val Salesperson/Agent at

cla-val.com/contact-us

CLOSER LOOK

CLOSER LOOK