

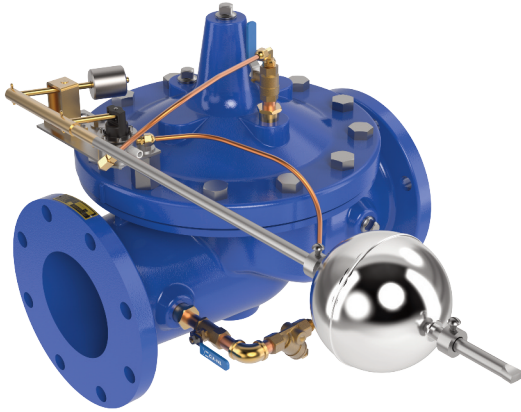

# MODEL— 124-14 Float Valve with Pressure Sustaining Control

- Accurate and Repeatable Level Control
- Fully Adjustable High and Low Level Settings
- Simple Design, Proven Reliable
- Easy Installation and Maintenance



The Cla-Val Model 124-14 Float Valve accurately controls the liquid level in tanks as well sustains pressure using a CRL or CRL-60 Pressure Relief Pilot Control to a pre-determined set point. The valve is designed to open when level reaches a low level, while still maintaining the pre-set upstream pressure. When the liquid level reaches a pre-set high point, the valve will close drip-tight.

This is a hydraulically operated, diaphragm valve with the pilot control and float mechanism mounted on the cover of the main valve. The float positions the pilot control to close the valve when the float contacts the upper stop. The high and low liquid levels are adjusted by positioning the stop collars on the float rod. The difference between high and low levels can be adjusted to as little as 1" (25 mm), or to as much as 18" (450 mm).

Level settings can be as much as 11.5 feet (17,526 mm) below the valve. The float mechanism may be located remotely from the main valve.

## Schematic Diagram

### Item Description

- 1 100-01 Hytrol Main Valve
- 2 X42N-3 Strainer Needle Valve
- 3 CRL/CRL-60 Pressure Relief Control
- 4 CF1-C1 Float Control
- 5 100-01 Hytrol (Reverse Flow)

## Optional Features

### Item Description

- B CK2 Isolation Valve
- D Check Valves with Cock
- F Remote Pilot Sensing
- H Drain to Atmosphere
- M X144 e-FlowMeter
- P X141 Pressure Gauge
- S CV Flow Control (Opening)
- V X101 Valve Position Indicator

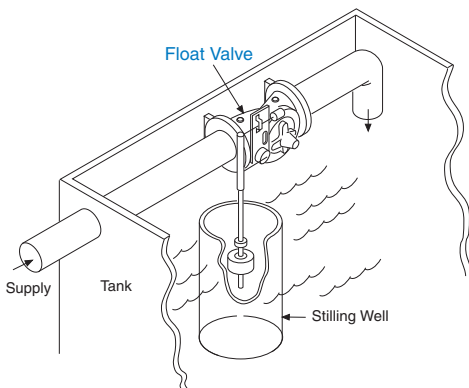
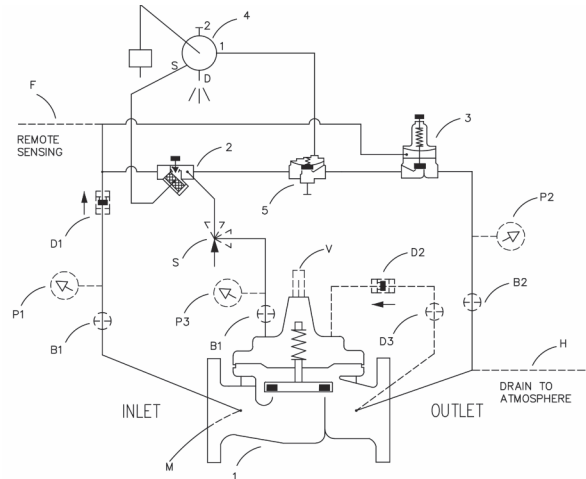

## Typical Application

The Model 124-14 Float Valve is commonly mounted above the high water level in a tank. Globe pattern valves are supplied standard with the float control mounted on the cover as illustrated, with a horizontal discharge. Angle pattern valves are configured to discharge downward.

### Notes:

1. We recommend protecting tubing and valve from freezing temperatures.
2. Must be inspected periodically.

## Installation

A stilling well (8" / 300mm minimum diameter) must be provided around the float. When the valve is mounted on top of the tank roof, a 2" (50mm) clearance hole should be provided for side movement of the float rod where the rod goes through the top of the tank.

A clear independent source of air or water may be used to operate the valve (option F). The pressure from this independent source must at all times be equal to or greater than pressure at the valve inlet. If minimum flowing line pressure is less than 10 psi, consult factory.

If the float control is remotely mounted from the main valve, the control may be installed at any elevation above the valve, provided the flowing line pressure in psi is greater than the vertical distance in feet between the valve and the float control. See the technical data sheet on Model CF1-C1 for additional information.

## Model 124-14 (Uses 100-01 Hytrol Main Valve)

### Pressure Ratings (Recommended Maximum Pressure - psi)

Valve Body & Cover		Pressure Class			
		Flanged		Threaded	
Grade	Material	ANSI Standards*	150 Class	300 Class	End† Details
ASTM A536	Ductile Iron	B16.42	250	400	400
ASTM A216-WCB	Cast Steel	B16.5	285	400	400
UNS 87850	Bronze	B16.24	225	400	400

Note: \* ANSI standards are for flange dimensions only.  
 Flanged valves are available faced but not drilled.  
 † End Details machined to ANSI B2.1 specifications.  
**Valves for higher pressure are available; consult factory for details**

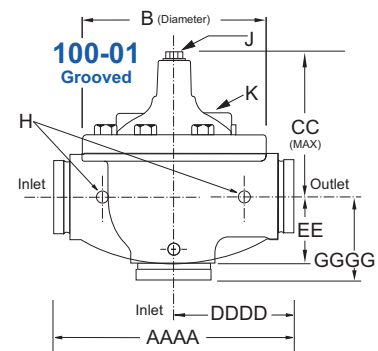
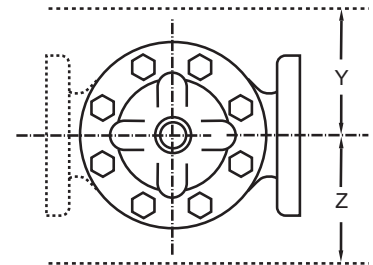
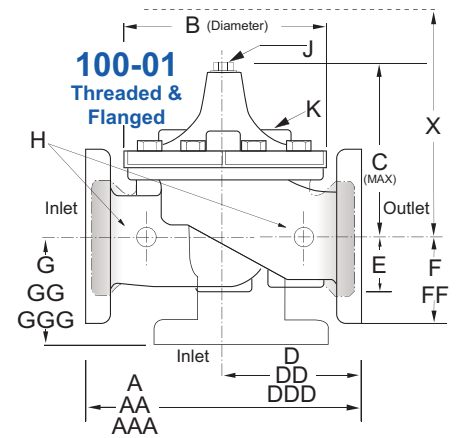

### Materials

Component	Standard Material Combinations		
Body & Cover	Ductile Iron	Cast Steel	Bronze
Available Sizes (inches)	½" - 6"	½" - 6"	½" - 6"
Available Sizes (mm)	15 - 150	15 - 150	15 - 150
Disc Retainer & Diaphragm Washer	Cast Iron	Cast Steel	Bronze
Trim: Disc Guide, Seat & Cover Bearing	Bronze is Standard Stainless Steel is Optional		
Disc	Buna-N® Rubber		
Diaphragm	Nylon Reinforced Buna-N® Rubber		
Stem, Nut & Spring	Stainless Steel		
For material options not listed, consult factory. Cla-Val manufactures valves in more than 50 different alloys.			

### Model 124-14 Dimensions (inches)

Valve Size (Inches)	½*	¾*	1*	1	1¼	1½	2	2½	3	4	6
A Threaded	3.50	3.50	5.12	7.25	7.25	7.25	9.38	11.00	12.50	—	—
AA 150 ANSI	—	—	—	—	—	8.50	9.38	11.00	12.00	15.00	20.00
AAA 300 ANSI	—	—	—	—	—	9.00	10.00	11.62	13.25	15.62	21.00
AAAA Grooved End	—	—	—	—	—	8.50	9.00	11.00	12.50	15.00	20.00
B Diameter	3.12	3.12	4.38	5.62	5.62	5.62	6.62	8.00	9.12	11.50	15.75
C Maximum	5.88	5.88	6.25	5.50	5.50	5.50	6.50	7.56	8.19	10.62	13.38
CC Maximum Grooved End	—	—	—	—	—	4.75	5.75	6.88	7.25	9.31	12.12
D Threaded	—	—	—	3.25	3.25	3.25	4.75	5.50	6.25	—	—
DD 150 ANSI	—	—	—	—	—	4.00	4.75	5.50	6.00	7.50	10.00
DDD 300 ANSI	—	—	—	—	—	4.25	5.00	5.88	6.38	7.88	10.50
DDDD Grooved End	—	—	—	—	—	—	4.75	—	6.00	7.50	—
E	0.88	0.88	1.63	1.12	1.12	1.12	1.50	1.69	2.06	3.19	4.31
EE Grooved End	—	—	—	—	—	2.00	2.50	2.88	3.12	4.25	6.00
F 150 ANSI	—	—	—	—	—	2.50	3.00	3.50	3.75	4.50	5.50
FF 300 ANSI	—	—	—	—	—	3.06	3.25	3.75	4.13	5.00	6.25
G Threaded	—	—	—	1.88	1.88	1.88	3.25	4.00	4.50	—	—
GG 150 ANSI	—	—	—	—	—	4.00	3.25	4.00	4.00	5.00	6.00
GGG 300 ANSI	—	—	—	—	—	4.25	3.50	4.31	4.38	5.31	6.50
GGGG Grooved End	—	—	—	—	—	—	3.25	—	4.25	5.00	—
H NPT Body Tapping	0.125	0.125	0.25	0.375	0.375	0.375	0.375	0.50	0.50	0.75	0.75
J NPT Cover Center Plug	0.125	0.125	0.25	0.25	0.25	0.25	0.50	0.50	0.50	0.75	0.75
K NPT Cover Tapping	0.125	0.125	0.25	0.375	0.375	0.375	0.375	0.50	0.50	0.75	0.75
Stem Travel	—	—	—	0.40	0.40	0.40	0.60	0.70	0.80	1.10	1.70
Approx. Ship Weight (lbs)	3	8	8	15	15	15	35	50	70	140	285

**Model 124-14 Metric Dimensions** (Uses 100-01 Hytrol Main Valve)

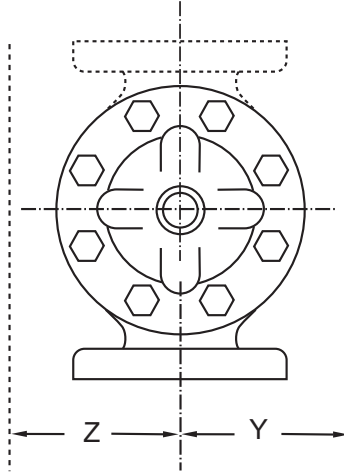
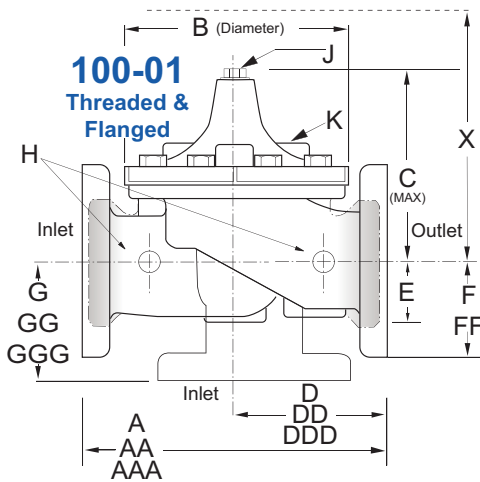

**Float Control Overview**

The Cla-Val Model CF1-C1 Float Control is a float-actuated, multi-port pilot control which provides non-modulating, two-position, on-off operation. It is used primarily to operate remotely located Cla-Val valves requiring three-way or four-way pilot valve operation. Designed for used in open tanks, this control operates on a minimum level change of approximately one inch.

**CF1-C1 Stainless Steel Float**

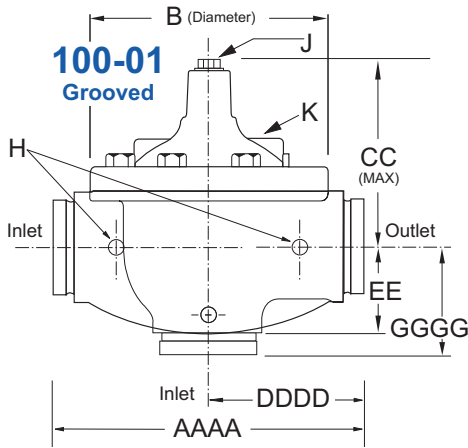

**Model 124-14 Dimensions (mm)**

Valve Size (mm)	15*	20*	25*	25	32	40	50	65	80	100	150
A Threaded	89	89	130	184	184	184	238	279	318	—	—
AA 150 ANSI	—	—	—	—	—	216	238	279	305	381	508
AAA 300 ANSI	—	—	—	—	—	229	254	295	337	397	533
AAAA Grooved End	—	—	—	—	—	216	228	279	318	381	508
B Diameter	80	80	111	143	143	143	168	203	232	292	400
C Maximum	149	149	159	140	140	140	165	192	208	270	340
CC Maximum Grooved End	—	—	—	—	—	120	146	175	184	236	308
D Threaded	—	—	—	83	83	83	121	140	159	—	—
DD 150 ANSI	—	—	—	—	—	102	121	140	152	191	254
DDD 300 ANSI	—	—	—	—	—	108	127	149	162	200	267
DDDD Grooved End	—	—	—	—	—	—	121	—	152	191	—
E	23	23	42	29	29	29	38	43	52	81	110
EE Grooved End	—	—	—	—	—	52	64	73	79	108	152
F 150 ANSI	—	—	—	—	—	64	76	89	95	114	140
FF 300 ANSI	—	—	—	—	—	78	83	95	105	127	159
G Threaded	—	—	—	48	48	48	83	102	114	—	—
GG 150 ANSI	—	—	—	—	—	102	83	102	102	127	152
GGG 300 ANSI	—	—	—	—	—	102	89	110	111	135	165
GGGG Grooved End	—	—	—	—	—	—	83	—	108	127	—
H NPT Body Tapping	0.125	0.125	0.25	0.375	0.375	0.375	0.375	0.50	0.50	0.75	0.75
J NPT Cover Center Plug	0.125	0.125	0.25	0.25	0.25	0.25	0.50	0.50	0.50	0.75	0.75
K NPT Cover Tapping	0.125	0.125	0.25	0.375	0.375	0.375	0.375	0.50	0.50	0.75	0.75
Stem Travel	—	—	—	10	10	10	15	18	20	28	43
Approx. Ship Weight (kgs)	1.4	1.4	6	7	7	7	16	23	32	64	129

124-14 Valve Selection	100-01 Pattern: Globe (G), Angle (A), End Connections: Threaded (T), Grooved (GR), Flanged (F) Indicate Available Sizes																		
	Inches	½	¾	1	1¼	1½	2	2½	3	4	6	8	10	12	14	16	18	20	24
	mm	15	20	25	32	40	50	65	80	100	150	200	250	300	350	400	450	500	600
Main Valve 100-01	Pattern	G	G	G, A	G, A	G, A	G, A	G, A	G, A	G, A	G, A	See the 124-02/624-02 Technical Data Sheet for larger sizes.							
	End Detail	T	T	T	T	T, F, Gr*	T, F, Gr	T, F, Gr*	T, F, Gr	F, Gr	F, Gr*								
Suggested Flow (gpm)	Maximum	19	33	55	93	125	210	300	460	800	1800								
	Maximum Intermittent	24	42	68	120	160	260	370	580	990	2250								
Suggested Flow (Liters/Sec)	Maximum	1.2	2.1	3.5	6	8	13	19	29	50	113								
	Maximum Intermittent	1.5	2.6	4.3	7.6	10	16	23	37	62	142								

100-01 Series is the full internal port Hytrol.

\*Globe Grooved Only

## Pilot System Dimensions

### 124-14 Float Valve (Globe)

Size	½"-¾"	1"	1¼"-1½"	2"	2½"	3"	4"	6"
	(15 - 20mm)	(25 mm)	(32 - 40 mm)	(50 mm)	(65 mm)	(80 mm)	(100 mm)	(150 mm)
X	2.50" (65 mm)	5.50" (140 mm)	6.00" (150 mm)	6.25" (160 mm)	6.75" (170 mm)	7.25" (180 mm)	8.00" (200 mm)	10.25" (260 mm)
Y	4.25" (108 mm)	4.75" (120 mm)	6.75" (170 mm)	7.00" (178 mm)	7.75" (197 mm)	8.25" (210 mm)	9.50" (240 mm)	10.50" (265 mm)
Z (MAX)*	29.75" (756 mm)	28.50" (724 mm)	28.25" (718 mm)	28.50" (724 mm)	28.75" (730 mm)	29.00" (737 mm)	29.25" (743 mm)	29.25" (743 mm)

### 124-14 Float Valve (Angle)

Size	1½"	2"	2½"	3"	4"	6"
	(40 mm)	(50 mm)	(65 mm)	(80 mm)	(100 mm)	(150 mm)
X	6.00" (150 mm)	6.25" (160 mm)	6.75" (170 mm)	7.25" (180 mm)	8.25" (210 mm)	10.50" (265 mm)
Y	6.75" (170 mm)	7.00" (178 mm)	7.75" (197 mm)	7.06" (179 mm)	9.00" (230 mm)	10.00" (254 mm)
Z (MAX)*	28.25" (718 mm)	28.50" (724 mm)	28.75" (730 mm)	29.00" (737 mm)	29.25" (743 mm)	29.25" (743 mm)

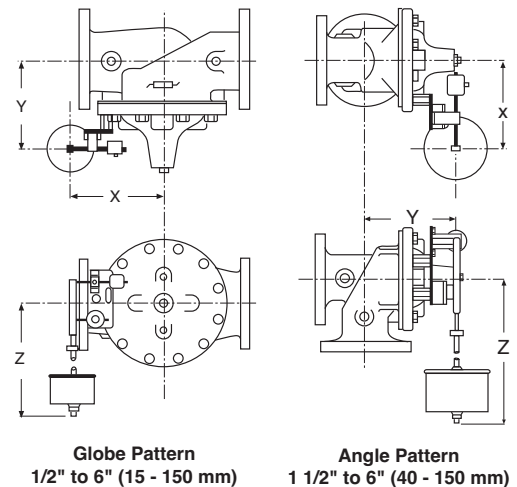

#### Notes:

- 1) \*Z (Max.) is with standard float rod.
- 2) We recommend providing adequate space around valve for maintenance work
- 3) Dimensions cover Threaded, Flanged and Grooved connections.

## Pilot System Specifications

### Pressure Rating

300 psi Max.

### Temperature Rating

Water: to 180°F (82°C) Maximum

### Materials

In contact with operating fluid:

Nylon-reinforced Delrin, Stainless Steel,

Monel, with Buna-N® seals

Float linkage and float rod: Brass and PVC

Base plate: 316 Stainless Steel

Float: 304 Stainless Steel

### Float

5<sup>3</sup>/<sub>8</sub>" (180mm) diameter.

### Float Rod

Standard: Two 12" (300mm) sections PVC rod, 6" (150 mm) & smaller

12" (300mm) extension increments at additional cost. Larger counterweight required if float rod length exceeds 5' (1524mm).

**Optional:** 24" (600mm) stainless steel rod, with 24" (600mm) extension increments at additional cost. Larger counterweight required if float rod length exceeds 2' (600mm).

If maximum temperature exceeds 160°F (71°C) specify stainless steel float rod.

### Adjustment Range

Level Differential:

1" min. to 18" max. (25 - 450mm) with PVC rod.

1" min to 40" max. (25 - 1016mm) with stainless steel rod.

### Operating Fluids

Clean liquids or gases compatible with specified materials.

### When Ordering, Please Specify

1. Catalog No. 124-14
2. Valve Size
3. Pattern - Globe or Angle
4. Pressure Class
5. Threaded or Flanged
6. Float Rod Material and Length
7. Float Ball Material
8. Desired Options
9. When Vertically Installed