

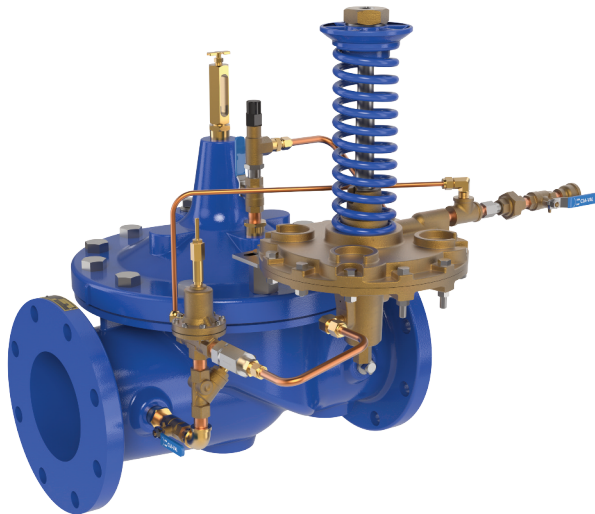

MODEL— 610-02

Altitude Valve For Two-Way Flow with Delayed Opening



- **Accurate and Repeatable Level Control**
- **Drip-Tight Positive Shut-Off**
- **Reliable Hydraulic Operation**
- **Easily Adjustable Control**
- **Completely Automatic Operation**

The Cla-Val Model 610-02 Altitude Valve controls the high water level in reservoirs without the need for floats or other devices. It is a non-throttling valve that remains fully open until the shut-off point is reached. This valve closes at the high water level, and for return flow, delays its opening until the pressure at the valve inlet lowers to a preset adjustable pressure of one to seven pounds.

This valve is hydraulically operated and pilot controlled. The pilot control operates on the differential in forces between a spring load and the water level in the reservoir. When the force of the spring is overcome by the force of the reservoir head, the pilot closes the main valve. The desired high water level is set by adjusting the spring force. The pilot control measures the reservoir head through a customer supplied sensing line* connected directly to the reservoir.

This valve can also be furnished with auxiliary controls to meet the need for multiple functions, such as: pressure sustaining, pressure reduction, rate of flow control, solenoid override, etc.

Schematic Diagram

Item	Description
1	100-20 Hytrol Main Valve
2	CDS6A Altitude Control
3	X101 Valve Position Indicator
4	Bell Reducer
5	X58A Restriction Assembly
6	CSC Swing Check Valve
7	CVC Flow Check Control
8	CV Flow Control (Closing)

Optional Features

Item	Description
A	X46A Flow Clean Strainer
B	CK2 Isolation Valve
R	Reservoir Gauge with Tester
S	CV Flow Control (Opening)
Y	X43 "Y" Strainer

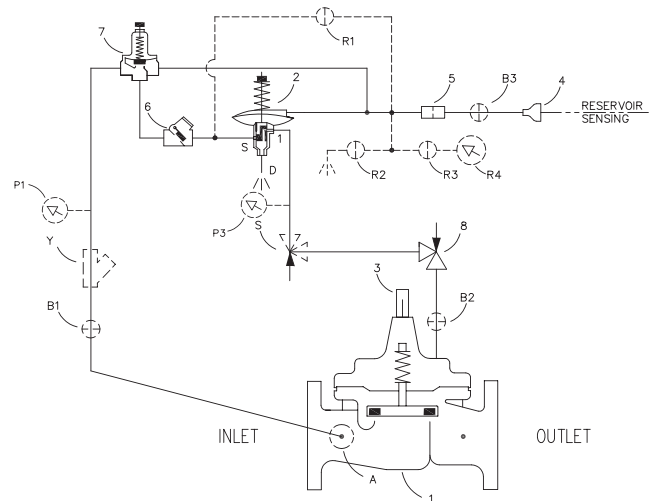

Typical Applications

Used on reservoirs where water is supplied and withdrawn through the altitude valve. The valve closes at the high water level. When pressure at the valve inlet lowers to the desired opening point, the pilot control opens the main valve for return flow to the system. The return flow pressure setting is adjustable to 6 psi below the shut-off pressure. For more information see data sheet E-CDS6A.

*Note: The reservoir pressure sensing line should be 3/4" minimum I.D. installed with a 2° slope from the valve to the reservoir slope to avoid air pockets.

Note: We recommend protecting tubing and valve from freezing temperatures.

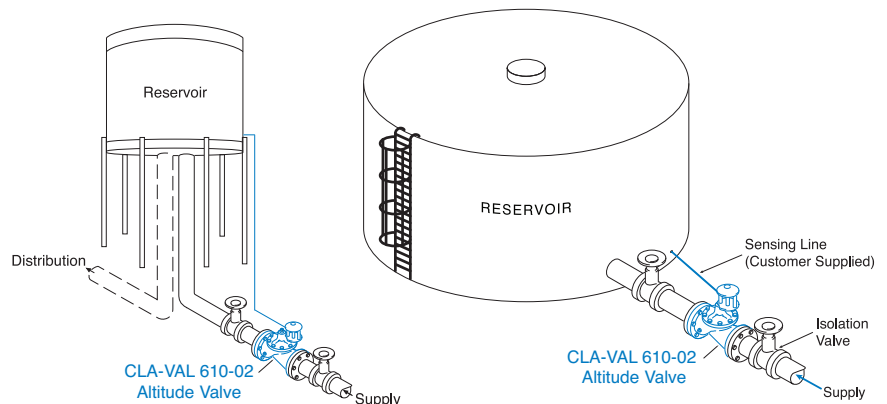

Model 610-02 (Uses Basic Valve Model 100-20)

Pressure Ratings (Recommended Maximum Pressure - psi)

Valve Body & Cover		Pressure Class		
		Flanged		
Grade	Material	ANSI Standards*	150 Class	300 Class
ASTM A536	Ductile Iron	B16.42	250	400
ASTM A216-WCB	Cast Steel	B16.5	285	400
UNS 87850	Bronze	B16.24	225	400

Note: * ANSI standards are for flange dimensions only.
 Flanged valves are available faced but not drilled.
 † End Details machined to ANSI B2.1 specifications.
Valves for higher pressure are available; consult factory for details

Materials

Component	Standard Material Combinations		
	Ductile Iron	Cast Steel	Bronze
Body & Cover	Ductile Iron	Cast Steel	Bronze
Available Sizes	3" - 48" 80 - 1200 mm	3" - 16" 80 - 400 mm	3" - 16" 80 - 400 mm
Disc Retainer & Diaphragm Washer	Cast Iron	Cast Steel	Bronze
Trim: Disc Guide, Seat & Cover Bearing	Bronze is Standard Stainless Steel is Optional		
Disc	Buna-N® Rubber		
Diaphragm	Nylon Reinforced Buna-N® Rubber		
Stem, Nut & Spring	Stainless Steel		

For material options not listed, consult factory.
 Cla-Val manufactures valves in more than 50 different alloys.

Cover Capacity

Liquid Volume Displaced from Diaphragm Chamber When Valve Opens or Closes

Valve Size	Displacement
3"	.032 gal
4"	.080 gal
6"	.169 gal
8"	.531 gal
10"	1.26 gal
12"	2.51 gal
14"	2.51 gal
16"	4.00 gal
18"	4.00 gal
20"	9.57 gal
24"	9.57 gal
30"	29.00 gal

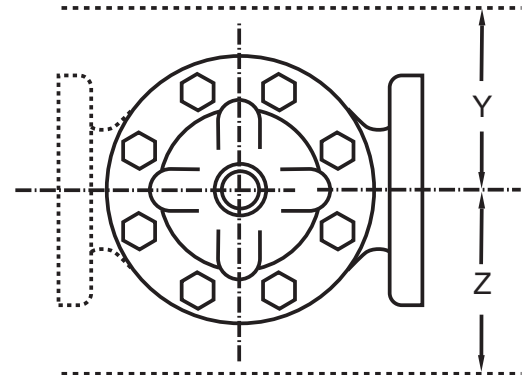
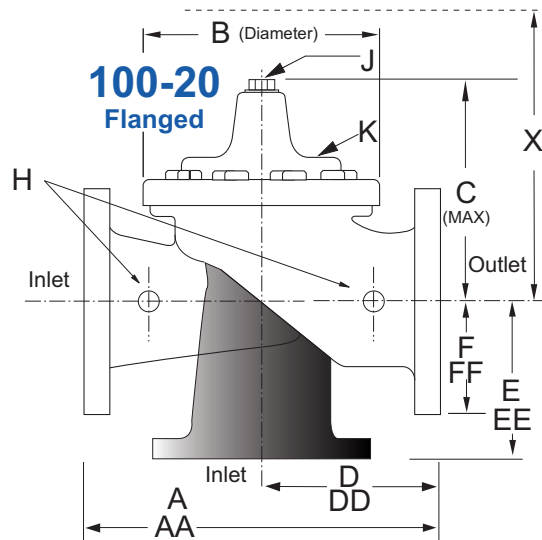

Model 610-02 Dimensions (In Inches)

Valve Size (Inches)	3	4	6	8	10	12	14	16	18	20	24	30	36	48
A 150 ANSI	10.25	13.88	17.75	21.38	26.00	30.00	34.25	35.00	42.12	48.00	48.00	63.25	65.00	88.0
AA 300 ANSI	11.00	14.50	18.62	22.38	27.38	31.50	35.75	36.62	43.63	49.62	49.75	63.75	67.00	90.62
B Diameter	6.62	9.12	11.50	15.75	20.00	23.62	27.47	28.00	35.44	35.44	35.44	53.19	56.00	66.00
C Maximum	7.00	8.62	11.62	15.00	17.88	21.00	20.88	25.75	25.00	31.50	31.50	43.94	54.75	59.00
D 150 ANSI	—	6.94	8.88	10.69	12.75	14.94	—	—	20.93	21.06	—	—	—	—
DD 300 ANSI	—	7.25	9.38	11.19	—	—	—	—	—	—	—	—	—	—
E 150 ANSI	—	5.50	6.75	7.25	8.06	8.68	—	—	15.81	15.94	—	—	—	—
EE 300 ANSI	—	5.81	7.25	7.75	—	—	—	—	—	—	—	—	—	—
F 150 ANSI	3.75	4.50	5.50	6.75	8.00	9.50	11.00	11.75	15.88	14.56	17.00	19.88	25.50	34.00
FF 300 ANSI	4.12	5.00	6.25	7.50	8.75	10.25	11.50	12.75	15.88	16.06	19.00	22.00	27.50	38.50
H NPT Body Tapping	0.375	0.50	0.75	0.75	1.00	1.00	1.00	1.00	1.00	1.00	1.00	1.00	2.00	2.00
J NPT Cover Center Plug	0.50	0.50	0.75	0.75	1.00	1.00	1.25	1.25	2.00	2.00	2.00	1.00	2.00	2.00
K NPT Cover Tapping	0.375	0.50	0.75	0.75	1.00	1.00	1.00	1.00	1.00	1.00	1.00	1.00	2.00	2.00
Stem Travel	0.60	0.80	1.10	1.70	2.30	2.80	3.40	4.50	4.50	4.50	6.50	7.50	7.50	8.50
Approx. Ship Weight (lbs)	45	85	195	330	625	900	1250	1380	2365	2551	2733	6500	8545	13100
Approx. X Pilot System	13	15	27	30	33	36	36	41	40	46	55	68	79	86
Approx. Y Pilot System	10	11	18	20	22	24	26	26	30	30	30	39	40	47
Approx. Z Pilot System	10	11	18	20	22	24	26	26	30	30	30	39	42	49

Model 610-02 Metric Dimensions (Uses Main Valve Model 100-20)

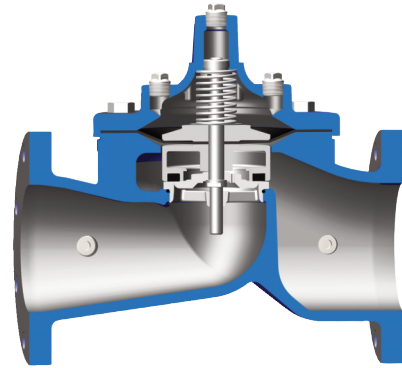
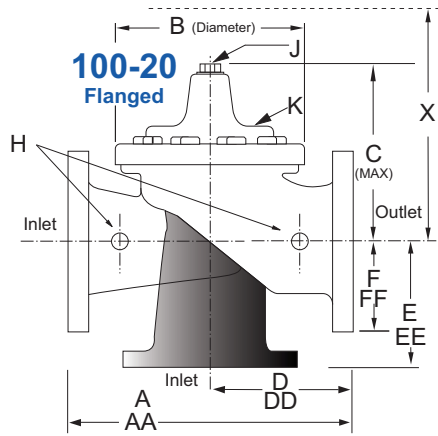

Model 100-20 Reduced Port Hytrol Main Valve

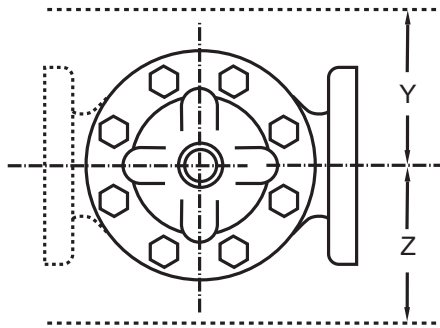

610-02 Dimensions (mm)

Valve Size (mm)	80	100	150	200	250	300	350	400	450	500	600	750	900	1200
A 150 ANSI	260	353	451	543	660	762	870	889	1070	1219	1219	1607	1651	2235
AA 300 ANSI	279	368	473	568	695	800	908	930	1108	1260	1263	1619	1702	2302
B Diameter	168	232	292	400	508	600	698	711	900	900	900	1351	1422	1676
C Maximum	178	219	295	381	454	533	530	654	635	800	800	1116	1391	1499
D 150 ANSI	—	176	226	272	324	380	—	—	532	535	—	—	—	—
DD 300 ANSI	—	184	238	284	—	—	—	—	—	—	—	—	—	—
E 150 ANSI	—	140	171	184	205	349	—	—	402	405	—	—	—	—
EE 300 ANSI	—	148	184	197	—	—	—	—	—	—	—	—	—	—
F 150 ANSI	95	114	140	171	203	241	279	289	403	370	432	505	648	864
FF 300 ANSI	105	127	159	191	222	260	292	324	403	408	483	559	699	978
H NPT Body Tapping	0.375	0.50	0.75	0.75	1.00	1.00	1.00	1.00	1.00	1.00	1.00	1.00	2.00	2.00
J NPT Cover Center Plug	0.50	0.50	0.75	0.75	1.00	1.00	1.25	1.25	2.00	2.00	2.00	1.00	2.00	2.00
K NPT Cover Tapping	0.375	0.50	0.75	0.75	1.00	1.00	1.00	1.00	1.00	1.00	1.00	1.00	2.00	2.00
Stem Travel	15	20	28	43	58	71	86	86	114	114	114	165	191	216
Approx. Ship Weight (kgs)	20	39	89	150	284	409	568	627	681	1157	1249	2951	3876	5942
Approx. X Pilot System	331	381	686	762	839	915	915	1042	1016	1169	1397	1728	2007	2185
Approx. Y Pilot System	254	280	458	508	559	610	661	661	762	762	762	991	1016	1194
Approx. Z Pilot System	254	280	458	508	559	610	661	661	762	762	762	991	1067	1245

610-02 Valve Selection	100-20 Pattern: Globe (G), Angle (A), End Connections: Flanged (F) Indicate Available Sizes															
	Inches	3	4	6	8	10	12	14	16	18	20	24	30	36	42	48
	mm	80	100	150	200	250	300	350	400	450	500	600	750	900	1000	1200
Main Valve 100-20	Pattern	G	G, A	G, A	G, A	G	G	G	G	G	G	G	G	G	G	G
	End Detail	F	F	F	F	F	F	F	F	F	F	F	F	F	F	F
Suggested Flow (gpm)	Maximum	260	580	1025	2300	4100	6400	9230	9230	16500	16500	16500	28000	33500	33500	33500
Suggested Flow (Liters/Sec)	Maximum	16	37	65	145	258	403	581	581	1040	1040	1040	1764	2115	2115	2115

100-20 Series is the reduced internal port size version of the 100-01 Series.

Pilot System Specifications

Adjustment Ranges

- 5 - 40 ft.
- 30 - 80 ft.
- 70 - 120 ft.
- 110 - 160 ft.
- 150 - 200 ft.

Temperature Range

Water: to 180°F

If flowing line pressure is less than 10 psi, consult factory for full details.

If inlet pressure is above 150 psi, consult factory for recommendations.

Materials

Standard Pilot System Materials

- Pilot Control: Low Lead Bronze
- Trim: Stainless Steel Type 303
- Rubber: Buna-N® Synthetic Rubber

Optional Pilot System Materials

Pilot Systems are available with optional Aluminum, Stainless Steel, or Monel materials. Valve position indicator is standard

Altitude Pilot Control Overview



- **Very Accurate and Reliable**
- **Low Maintenance**
- **Bronze and Stainless Steel Wetted Parts**

The Cla-Val Model CDS6A Altitude Pilot Control is a spring-loaded, three-way, diaphragm-actuated control that provides high-level shutoff for Cla-Val 210 Series Altitude Control Valves. The CDS6A controls the high water level in a reservoir or tank without the need for floats or other devices. It is a non-throttling pilot that remains fully open until the reservoir reaches the high level shutoff point. High accuracy is assured by remotely sensing the pressure head of the reservoir or tank. The single adjusting nut can be easily set in the field to close the main valve when liquid level reaches the desired high level set-point within five adjustment ranges.

The CDS6A operating principle uses a differential in forces between the spring load and the hydraulic head of the fluid level in the reservoir or tank to activate the pilot valve of the control. When the force of the spring setting (or the desired high level shutoff point) is overcome by the force of the reservoir head, the pilot valve shifts positions automatically and closes the main valve. When the reservoir head is eight to ten inches less than the spring setting, the pilot valve shifts to open the main valve.

When Ordering Please Specify

1. Catalog No. 610-02
2. Valve Size
3. Pattern - Globe or Angle
4. Pressure Class
5. Threaded or Flanged
6. Materials Desired
7. Adjustment Range
8. Desired Options
9. When Vertically Installed
10. When "D" feature is ordered, the "H" feature is required.

For a comprehensive overview of Cla-Val Altitude Control Valves, please visit www.cla-val.com and use keyword search "Altitude".



CLA-VAL

1701 Placentia Avenue • Costa Mesa, CA 92627

800-942-6326 • Web Site: www.cla-val.com • E-mail: info@cla-val.com

CLA-VAL CANADA

4687 Christie Drive
Beamsville, Ontario
Canada L0R 1B4
Phone: 905-563-4963
www.cla-val.com
E-mail sales@cla-val.ca

CLA-VAL EUROPE

Chemin des Mésanges 1
CH-1032 Romanel/
Lausanne, Switzerland
Phone: 41-21-643-15-55
www.cla-val.ch
E-mail: info@cla-val.ch

CLA-VAL UK

Dainton House, Goods Station Road
Tunbridge Wells
Kent TN11 2 DH England
Phone: 44-1892-514-400
www.cla-val.ch
E-mail: info@cla-val.co.uk

CLA-VAL FRANCE

Porte du Grand Lyon 1
ZAC du Champ du Périer
France - 01700 Neyron
Phone: 33-4-72-25-92-93
www.cla-val.ch
E-mail: info@cla-val.ch

CLA-VAL ASIA PACIFIC

45 Kennaway Road
Woolston, Christchurch, 8023
New Zealand
Phone: 64-39644860
www.cla-valpacific.com
E-mail: info@cla-valpacific.com