



— MODEL — **661-02**

Deep Well Pump Control Valve



- Prevent Surges in Pipelines
- Simple Hydraulic Operation
- Adjustable Opening and Closing Speeds
- Solenoid Control Can Be Operated Manually
- Proven Reliable Design

The Cla-Val Model 661-02 Deep Well Pump Control Valve is designed to protect pipelines from surges caused by the starting and stopping of deep well pumps. This is a hydraulically operated diaphragm valve which is controlled by a solenoid pilot valve. Separate adjustable flow control valves in the pilot system regulate the opening and closing rates. A limit switch on the valve stem serves as an electrical interlock between the valve and the pump motor.

The operation of the valve is completely automatic and controlled by the solenoid valve. With the pump off, the valve is wide open. When the pump is started, the solenoid is energized and the valve begins to close slowly, discharging air and the initial rush of sand and water from the pump column to atmosphere. As the valve closes the pump output is gradually diverted into the main line, preventing the development of a starting surge.

When it is time to shut-off the pump, the solenoid is de-energized. The pump continues to run while the pump control valve opens slowly, diverting pump output to atmosphere. As pump pressure gradually decreases, the main line check valve closes slowly, preventing shock or slam during the pump stopping cycle. When the pump control valve is wide open, the limit switch assembly releases the pump starter and the pump stops.

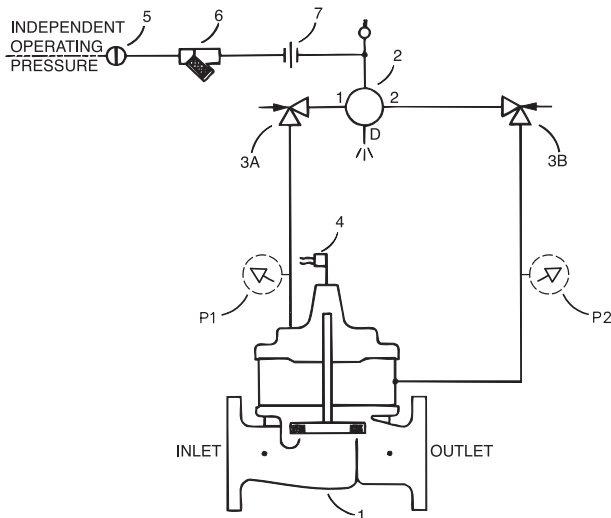

Schematic Diagram

Item	Description
1	100-21 Powertrol Main Valve
2	CSM11-A2-2 Solenoid Control
3	CV Flow Control
4	X105LOW Switch Assembly
5	CK (Isolation Valve)
6	X43 "Y" Strainer
7	Union

Options

Item	Description
P	X141 Pressure Gauge

Typical Installation

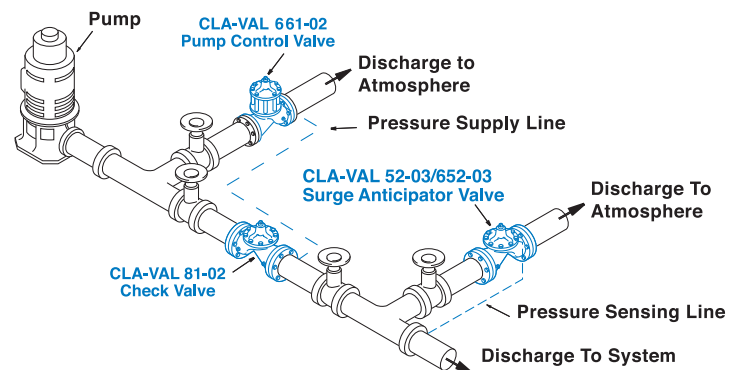

Install Model 661-02 valve as shown. Use a minimum of 12mm tubing to connect operating pressure connection of the valve to the system side of check valve. Flexible conduit should be used for electrical connections to the solenoid control and the limit switch assembly. A Model 52-02 or 652-03 Surge Anticipator is recommended for power failure and surge protection.

Pressure Ratings (Recommended Maximum Pressure - psi)

Valve Body & Cover		Pressure Class			
		Flanged			Threaded
Grade	Material	ANSI Standards*	150 Class	300 Class	End† Details
ASTM A536	Ductile Iron	B16.42	250	640	400
ASTM A216-WCB	Cast Steel	B16.5	285	720	400
UNS 87850	Bronze	B16.24	225	500	400

Note: * ANSI standards are for flange dimensions only.
 Flanged valves are available faced but not drilled.
 † End Details machined to ANSI B2.1 specifications.
Valves for higher pressure are available; consult factory for details

Materials

Component	Standard Material Combinations		
Body & Cover	Ductile Iron	Cast Steel	Bronze
100-21 Available Sizes	80 - 750 mm	80 - 400 mm	80 - 400 mm
Disc Retainer & Diaphragm Washer	Cast Iron	Cast Steel	Bronze
Trim: Disc Guide, Seat & Cover Bearing	Bronze is Standard Stainless Steel is Optional		
Disc	Buna-N® Rubber		
Diaphragm	Nylon Reinforced Buna-N® Rubber		
Stem, Nut & Spring	Stainless Steel		

For material options not listed, consult factory.
 Cla-Val manufactures valves in more than 50 different alloys.

Model 661-02 (uses 100-21 Powerrol Main Valve)

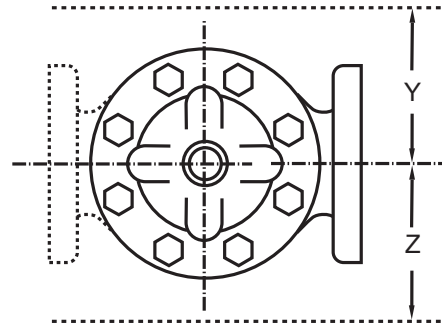
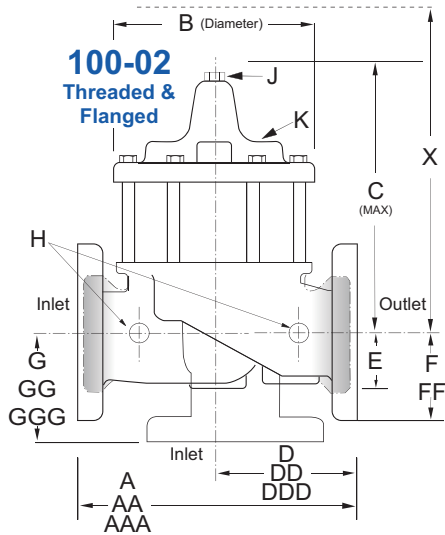

661-02 Series Dimensions (mm)

Valve Size (mm)	80	100	150	200	250	300	350	400	450	500	600	750
A 150 ANSI	260	353	451	543	660	762	870	889	1070	1219	1219	1607
AA 300 ANSI	279	368	473	568	695	800	908	930	1108	1260	1264	—
B Diameter	168	232	292	400	508	600	711	711	900	900	900	1351
C Maximum	235	298	387	514	603	692	744	867	889	1022	1022	1435
D 150 ANSI	—	176	226	272	—	—	—	—	—	—	—	—
DD 300 ANSI	—	184	238	284	—	—	—	—	—	—	—	—
E 150 ANSI	—	140	171	184	—	—	—	—	—	—	—	—
EE 300 ANSI	—	148	184	197	—	—	—	—	—	—	—	—
F 150 ANSI	95	114	140	171	203	241	279	298	403	370	432	505
FF 300 ANSI	105	127	159	191	222	260	—	324	403	408	483	—
H NPT Body Tapping	0.38	0.50	0.75	0.75	1.00	1.00	1.00	1.00	1.00	1.00	1.00	1.00
J NPT Cover Center Plug	0.50	0.50	0.75	0.75	1.00	1.00	1.25	1.25	2.00	2.00	2.00	2.00
K NPT Cover Tapping	0.38	0.50	0.75	0.75	1.00	1.00	1.00	1.00	1.00	1.00	1.00	1.00
Stem Travel	15	20	28	43	58	71	86	86	86	114	114	165
Approx. Ship Weight (kgs)	32	61	104	218	356	640	1006	1006	1044	1544	1634	3496
Approx. X Pilot System	406	457	787	914	991	1092	1143	1270	1270	1422	1626	2057
Approx. Y Pilot System	254	279	457	508	559	610	660	660	660	762	762	991
Approx. Z Pilot System	254	279	457	508	559	610	660	660	660	762	762	991

661-02 Valve Selection	100-21 Pattern: Globe (G), Angle (A), End Connections: Flanged (F) Indicate Available Sizes											
	Inches	3	4	6	8	10	12	14	16	18	20	24
	mm	80	100	150	200	250	300	350	400	450	500	600
Main Valve 100-21	Pattern	G	G, A	G, A	G, A	G	G	G	G	G	G	G
	End Detail	F	F	F	F	F	F	F	F	F	F	F
Suggested Flow (gpm)	Maximum	260	580	1025	2300	4100	6400	9230	9230	16500	16500	16500
Suggested Flow (Liters/Sec)	Maximum	16	37	65	145	258	403	581	581	1040	1040	1040

100-21 Series is the reduced internal port size version of the 100-02 Series. Consult factory for 750 mm Valve Selection Data.

CSM11 Solenoid Control Power Consumption

Volts	Amperes		Coil Resistance
	Holding	Inrush	Ohms
AC 60 Hz			
24	2.88	25.4	0.5
120	.575	5.1	14.1
208	.330	2.93	40
240	.288	2.54	58
440	.156	1.38	174
440	.143	1.27	233
Volts	Amperes		Coil Resistance
	Holding	Inrush	Ohms
(AC 50 Hz)			
110	.48	4.6	15.7
220	.24	2.3	66
240	.22	2.1	88



CSM11 Specifications

- Enclosure General purpose NEMA Type 3; Aluminum
Note: For other enclosures and NEMA Types, consult factory
- Housing Body — Aluminum
Trim — Stainless Steel
- Operating Pressure: Maximum pressure 300 psi, for higher pressure consult factory.
- Coil Insulation Class A (molded)
- AC voltage 15.4 watts

Pilot System Specifications

Temperature Range

Water to 180°F Max

Materials

Standard Pilot System Materials

- Pilot Control: Low Lead Bronze
- Trim: Stainless Steel Type 303
- Rubber: Buna-N® Synthetic Rubber

Optional Pilot System Materials

Pilot Systems are available with optional Aluminum, Stainless Steel or Monel materials.

Wiring Diagram

Auto-Off-Hand	= Selector Switch
1CR	= Relay, DPST Normally Open
2CR	= Relay, DPST Normally Open
3CR	= Relay, TPST Normally Open
SW ₁	= Switch, Remote Start, Automatic
SW ₂	= Switch, SPDT, Valve Limit Switch Connect to N.C. Terminal
PVS	= Pilot Valve Solenoid
M	= Pump Motor Starter

Note: SW₂ and PVS supplied by Cla-Val. All other electrical items supplied by customer. SW₂ is included in the X105L switch assembly which is mounted on the pump control valve cover.

Shown In Pump Off Position

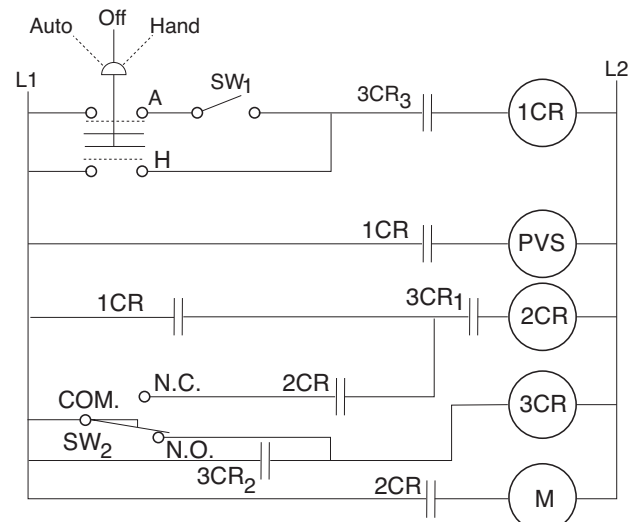

Sequence Of Operation

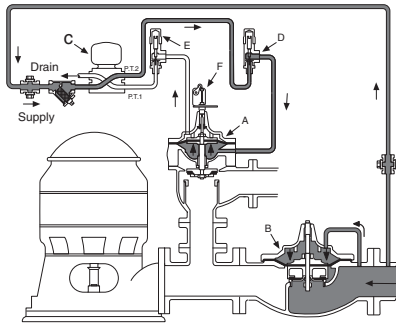

Pump Off...

With pump off, static line pressure holds the main line check valve "B" closed. Line pressure is transmitted through solenoid control "C" and speed control "D" to the lower chamber of valve "A". Upper chamber of pump control valve "A" is vented to atmosphere so valve "A" is held wide open.

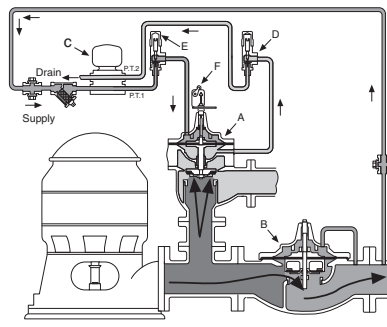

Starting Cycle...

Starting switch closes, pump starts, solenoid "C" energizes and shifts, allowing line pressure to flow into upper chamber of valve "A" through solenoid control "C" and opening speed control "E". Closing speed of valve "A" is controlled by speed control "D" which limits the rate fluid is relieved from under the diaphragm. As valve "A" closes, pumping pressure opens main line check valve "B", gradually permitting full flow.

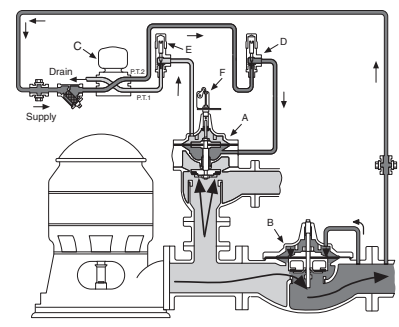

Stopping Cycle...

Starting switch opens, solenoid "C" de-energizes and shifts, as pump continues to run, pump pressure flows into lower chamber of valve "A" through solenoid "C" and opening speed control "D". Pressure in upper chamber of valve "A" is relieved to atmosphere through opening speed control "E" and solenoid control "C". As valve "A" opens, flow through main line check valve "B" gradually lessens until valve "A" is wide open and the limit switch "F" shuts off the pump.

Selecting The Valve

To be effective, this valve must be sized so it relieves to atmosphere that part of the pump discharge head which is in excess of the normal system static pressure. To do this, the valve is sized to permit the full pump discharge through the valve at a pressure low enough to keep the system check valve from opening. As the pump control valve closes, the pumping pressure exceeds the system pressure and gradually flows into the system.

We recommend selecting a valve size which will have a pressure loss that is at least 10 psi less than the system static pressure. Use the flow rate which is found on the pump's flow vs discharge pressure chart. Select the flow corresponding to the system static pressure, less 10 psi.

Determining Valve Size

1. Determine the system's static pressure (the pressure downstream of the check valve with the pump off); subtract 10 psi, this is the Design Pressure P.
2. From the pump's flow vs. discharge pressure curve, determine the flow (Q) at the Design Pressure P.
3. Using the formula, calculate the Cv.

$$Cv = \frac{Q}{\sqrt{P}}$$

4. Select the valve size from the table which has a Cv that is equal to, or greater than, the calculated Cv in step 3 above.

Example

1. System Static Pressure with the pump off = 70 psi.
2. Determine the Design Pressure P by subtracting 10 psi (70 psi - 10 psi = 60 psi Design Pressure)
3. From the pump curve we determine that the valve must allow a flow of 800 GPM at 60 psi.
4. Using the Formula:

$$Cv = \frac{Q}{\sqrt{P}} \quad \text{Where: } Q = 800 \text{ GPM} \\ P = 60 \text{ psi (70 psi - 10 psi)}$$

$$\text{Example } Cv = \frac{800}{\sqrt{60}} = 103$$

Valve Size	Globe	Angle
80	62	--
100	136	135
150	229	233
200	480	545
250	930	--
300	1458	--
350	--	--
400	2110	--
500	3400	--
600	3500	--

Consult Factory for Cv Values on sizes 450 mm and 750 mm.

Example (continued)

5. From the table above the best valve choices are:
100mm 661-02 Globe Pattern
100mm 661-02 Angle Pattern

Drain Provisions

Each time the valve opens or closes, water is discharged from the solenoid exhaust port, the amount varying with the valve size. Provisions should be made for the disposal of this water. Exhaust tube must be free of any back pressure. Provide an air gap between the solenoid exhaust tube and drain facility.

When Ordering, Please Specify:

- | | |
|-----------------------------|------------------------------|
| 1. Catalog No. 661-02 | 2. Valve Size |
| 3. Pattern - Globe or Angle | 4. Pressure Class |
| 5. Trim Material | 6. Electrical Selection |
| 7. Desired Options | 8. When Vertically Installed |
| 9. Epoxy Coating | |