



— MODEL — **81-12**

Check Valve



- Simple Proven Design
- No-Slam Operation
- Drip-Tight Shut-Off
- Recommended for Variable Speed Pumps
- No Packing Glands or Stuffing Boxes
- Easy to Install & Maintain

The Cla-Val Model 81-12 Check Valve is a hydraulically operated No-Slam Check Valve. This valve opens when the pressure at the inlet exceeds the discharge pressure. A gradual rate of opening prevents sudden opening surges. When a pressure reversal occurs the higher downstream pressure is applied to the cover chamber through the control tube lines, and the valve closes drip tight.

This valve is ideally suited for use where a positive shutoff is required. The rubber disc assures tight sealing even if the fluid contains grit or other small-size particles. The simple packless design insures reliable operation and freedom from leaks.

Schematic Diagram

Item	Description
1	100-01 Hytrol Main Valve

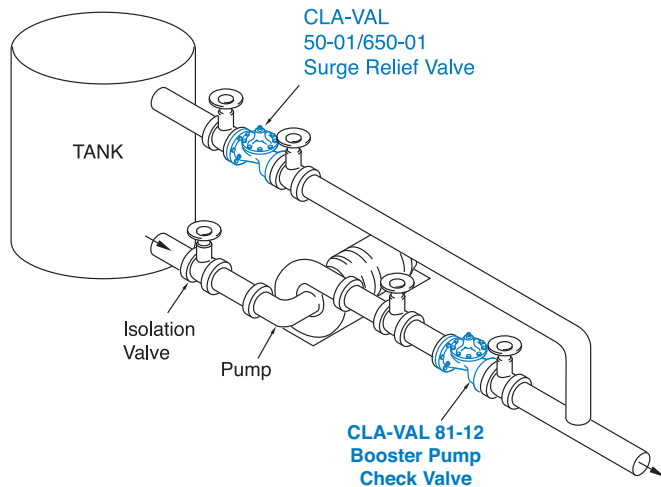
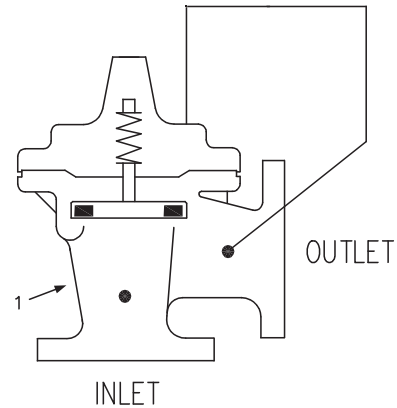

Typical Applications

Install on the discharge of booster pumps to prevent return flow when pump is off. Relief valve as shown is good practice to minimize surges when pump stops.

For valve sizes larger than 4", use Model 81-02.

81-12 Valve Selection	100-01 Pattern: Globe (G), Angle (A), End Connections: Threaded (T), Grooved (GR), Flanged (F) Indicate Available Sizes							
	Inches	1	1¼	1½	2	2½	3	4
	mm	25	32	40	50	65	80	100
Basic Valve 100-01	Pattern	G, A	G, A	G, A	G, A	G, A	G, A	G, A
	End Detail	T	T	T, F, GR	T, F, GR	T, F, GR*	T, F, GR	T, F, GR
Suggested Flow (gpm)	Maximum	16	28	38	64	90	140	240
Suggested Flow (Liters/Sec)	Maximum	1	1.8	2.4	4	5.7	8.8	15.1
100-01 Series is the full internal port Hytrol.								*Globe Grooved Only

Flowrates shown are for a velocity of 6 fps (1.8 m/s).

Velocities can be increased to 10 fps (3.05 m/s) if required, and the installation of a surge valve in the system is recommended in velocities above 6 ft/sec. (1.8 m/sec)

Pilot System Specifications

Temperature Rating

Water: to 180°F. Max.

Speed Controls

For valves with opening and closing speed controls order Model 81-02

Materials

Standard Pilot System Materials

Fittings: Brass
Tubing: Copper

Optional Pilot System Materials

Pilot Systems are available with optional stainless steel or Monel materials.

When ordering please specify:

1. Catalog No. 81-12
2. Valve Size
3. Pattern: Globe or Angle
4. Pressure Class
5. Threaded or Flanged
6. Desired Options
7. When Vertically Installed

Model 81-12 Dimensions (In Inches)

Valve Size (Inches)	1	1¼	1½	2	2½	3	4
A Threaded	7.25	7.25	7.25	9.38	11.00	12.50	—
AA 150 ANSI	—	—	8.50	9.38	11.00	12.00	15.00
AAA 300 ANSI	—	—	9.00	10.00	11.62	13.25	15.62
AAAA Grooved End	—	—	8.50	9.00	11.00	12.50	15.00
B Diameter	5.62	5.62	5.62	6.62	8.00	9.12	11.50
C Maximum	5.50	5.50	5.50	6.50	7.56	8.19	10.62
CC Maximum Grooved End	—	—	4.75	5.75	6.88	7.25	9.31
D Threaded	3.25	3.25	3.25	4.75	5.50	6.25	—
DD 150 ANSI	—	—	4.00	4.75	5.50	6.00	7.50
DDD 300 ANSI	—	—	4.25	5.00	5.88	6.38	7.88
DDDD Grooved End	—	—	—	4.75	—	6.00	7.50
E	1.12	1.12	1.12	1.50	1.69	2.06	3.19
EE Grooved End	—	—	2.00	2.50	2.88	3.12	4.25
F 150 ANSI	—	—	2.50	3.00	3.50	3.75	4.50
FF 300 ANSI	—	—	3.06	3.25	3.75	4.13	5.00
G Threaded	1.88	1.88	1.88	3.25	4.00	4.50	—
GG 150 ANSI	—	—	4.00	3.25	4.00	4.00	5.00
GGG 300 ANSI	—	—	4.25	3.50	4.31	4.38	5.31
GGGG Grooved End	—	—	—	3.25	—	4.25	5.00
H NPT Body Tapping	0.375	0.375	0.375	0.375	0.50	0.50	0.75
J NPT Cover Center Plug	0.25	0.25	0.25	0.50	0.50	0.50	0.75
K NPT Cover Tapping	0.375	0.375	0.375	0.375	0.50	0.50	0.75
Stem Travel	0.40	0.40	0.40	0.60	0.70	0.80	1.10
Approx. Ship Weight (lbs)	15	15	15	35	50	70	140

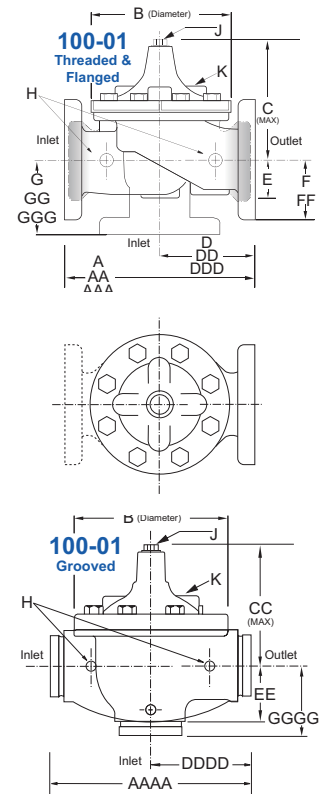

Pressure Ratings (Recommended Maximum Pressure - psi)

Valve Body & Cover		Pressure Class			
		Flanged			Threaded
Grade	Material	ANSI Standards*	150 Class	300 Class	300 Class
ASTM A536	Ductile Iron	B16.42	250	400	400
ASTM A216-WCB	Cast Steel	B16.5	285	400	400
UNS 87850	Bronze	B16.24	225	400	400

Note: * ANSI standards are for flange dimensions only.
Flanged valves are available faced but not drilled.
‡ End Details machined to ANSI B2.1 specifications.
Valves for higher pressure are available; consult factory for details

Materials

Component	Standard Material Combinations		
Body & Cover	Ductile Iron	Cast Steel	Bronze
Available Sizes	1" - 4"	1" - 4"	1" - 4"
Disc Retainer & Diaphragm Washer	Cast Iron	Cast Steel	Bronze
Trim: Disc Guide, Seat & Cover Bearing	Bronze is Standard Stainless Steel is Optional		
Disc	Buna-N® Rubber		
Diaphragm	Nylon Reinforced Buna-N® Rubber		
Stem, Nut & Spring	Stainless Steel		

For material options not listed, consult factory.
Cla-Val manufactures valves in more than 50 different alloys.