

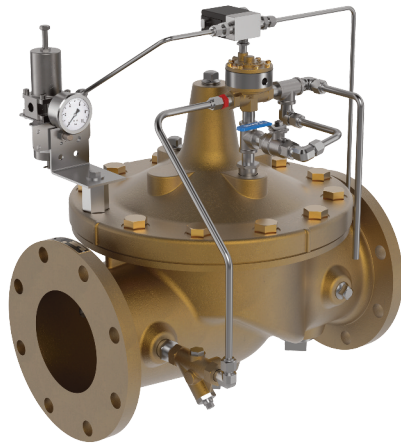

MODEL 134-61

Fire Deluge Solenoid and Remote Control Valve for Sea Water Service



- **cULus Listed**
- **Fast Acting Solenoid Control**
- **Reliable Drip Tight Shut-off**
- **Simple Design, Proven Reliable**
- **Easy Installation & Maintenance**

The Cla-Val Model 134-61 Seawater Service Solenoid Control Valve is an on-off pneumatic/hydraulic control valve which either opens or closes upon receiving an electrical signal to the solenoid pilot control. This valve consists of cULus listed 100GS/2100GS hytrol main valve, a three-way solenoid valve and an auxiliary pilot valve. This pilot control system alternately applies pressure to/or relieves pressure from the diaphragm chamber of the main valve. It is furnished either normally open (de-energize solenoid to open) or normally closed (energized solenoid to open).

Schematic Diagram

- | Item | Description |
|------|------------------------------------|
| 1 | 100GS Hytrol Main Valve |
| 2 | CS3XM Solenoid Control |
| 3 | 100-02 Powertrol (Auxiliary Valve) |
| 4 | X58C Restriction Assembly |
| 5 | Ball Valve |
| 6 | Regulator |

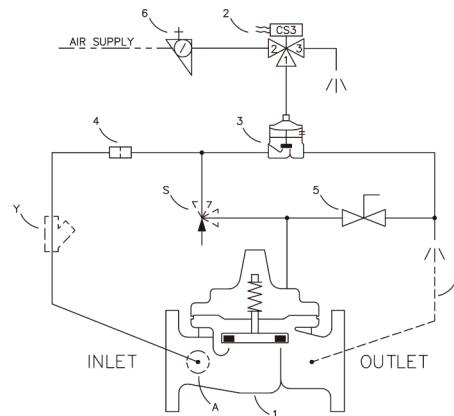

Specification

SIZES Globe: 3" - 12" flanged
Angle: 3" - 12" flanged

END DETAILS Ductile Iron 150 ANSI B16.42 flanged
Cast Steel 150 ANSI B16.5 flanged

PRESSURE RATINGS 150 class, 250 psi maximum (Ductile Iron)
150 class, 285 psi maximum (Cast Steel)
300 class, 400 psi maximum

TEMPERATURE RANGE Water: to 180° F. Max

MATERIALS Main valve body & cover

Ductile Iron ASTM A-536*
Cast Steel ASTM A216-WCB*
Nickel Aluminum Bronze ASTM B148 C95800
Super Duplex Stainless Steel ASTM A890 GR5A
Stainless Steel ASTM A743-CF-8M

Main valve trim:

Bronze / Monel

Tubeing & Fittings

316 SST, Monel, or 2507 SDS

Pilot control system:

Cast Bronze ASTM B61
cULus Listed 3" - 12"

Functional Data

Valve Size	Inches	3	4	6	8	10	12	
	mm	80	100	150	200	250	300	
Cv Factor	Globe Pattern	Gal./Min. (gpm.)	115	200	440	770	1245	1725
		Litres/Sec. (L/s)	27.6	48	105.6	184.8	299	414
	Angle Pattern	Gal./Min. (gpm.)	139	240	541	990	1575	2500
		Litres/Sec. (L/s)	33.4	58	130	238	378	600

Cover Capacity

Valve Size	Displacement
3"	.080 gal
4"	.169 gal
6"	.531 gal
8"	1.26 gal
10"	2.51 gal
12"	4.00 gal

100GS (Globe)

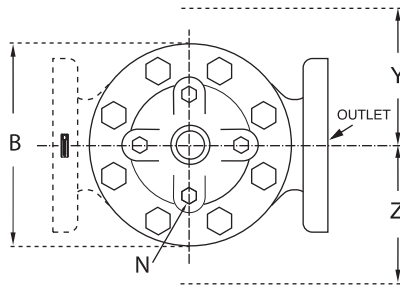
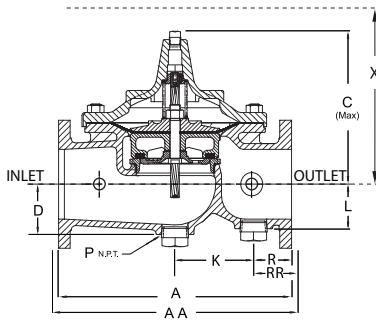

2100GS (Angle)

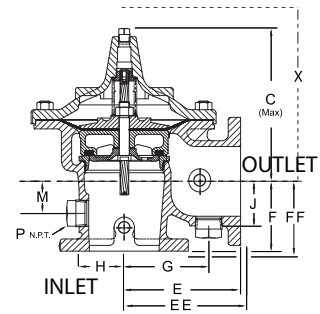

Valve Size (in)	3	4	6	8	10	12
A 150 ANSI	12.00	15.00	20.00	25.38	29.75	34.00
AA 300 ANSI	13.25	15.62	21.00	26.38	31.12	35.50
B Dia.	9.12	11.50	15.75	20.00	23.62	28.00
C Max.	8.19	10.62	13.28	16.00	17.12	21.00
D	2.56	3.19	4.31	5.16	8.50	9.39
E 150 ANSI	7.00	8.50	10.00	12.69	14.88	17.00
EE 300 ANSI	--	8.81	10.50	13.19	--	17.75
F 150 ANSI	4.00	4.97	6.00	8.00	8.62	13.75
FF 300 ANSI	--	5.28	6.50	8.50	--	14.50
G	4.75	5.94	7.25	8.50	10.50	17.00
H	2.69	2.81	3.88	5.31	6.56	7.00
J	2.56	2.81	3.81	4.81	5.81	7.00
K	7.00	4.03	6.75	17.00	15.50	21.00
L	2.56	2.81	3.81	4.81	8.50	9.39
M	1.75	2.41	2.75	4.00	4.24	8.75
N NPT	1/2"-14	3/4"-14	3/4"-14	1"-11 1/2	1"-11 1/2	1"-11 1/2
P NPT	1-1/4"-11 1/2"	2"-11 1/1/2"				
R 150 ANSI	2.50	3.47	3.25	4.19	7.12	6.50
RR 150 ANSI	3.12	3.78	3.75	4.69	7.81	7.25
X Pilot System	15.00	17.00	29.00	31.00	33.00	35.00
Y Pilot System	11.00	12.00	20.00	22.00	24.00	26.00
Z Pilot System	11.00	12.00	20.00	22.00	24.00	26.00

Valve Size (mm)	80	100	150	200	250	300
A 150 ANSI	305	381	508	645	756	864
AA 300 ANSI	337	397	533	670	791	902
B Dia.	232	292	400	508	600	711
C Max.	208	270	340	406	435	533
D	65	81	110	131	216	239
E 150 ANSI	178	216	254	322	378	432
EE 300 ANSI	--	224	267	350	--	451
F 150 ANSI	102	126	152	203	219	349
FF 300 ANSI	--	134	165	216	--	368
G	121	151	184	216	267	432
H	68	71	99	135	167	178
J	65	71	97	122	148	178
K	178	102	171	432	394	533
L	65	71	97	122	216	239
M	45	61	70	102	108	222
N NPT	1/2"-14	3/4"-14	3/4"-14	1"-11 1/2	1"-11 1/2	1"-11 1/2
P NPT	1-1/4"-11 1/2"	2"-11 1/1/2"				
R 150 ANSI	64	88	83	106	181	165
RR 150 ANSI	79	96	95	119	198	184
X Pilot System	381	432	737	787	838	889
Y Pilot System	279	305	508	559	610	660
Z Pilot System	279	305	508	559	610	660

Pilot System Specifications

Temperature Range

Water: to 180°F

Fluids

Air, water, light oils

Rubber Parts

Buna-N® Synthetic Rubber

Solenoid Control*

Body:

316 SS

Enclosure:

NEMA Type 1, 2, 3, 3S, 4, 4X general purpose watertight

NEMA Type 6, 6P, 7, 9 watertight

Explosion Proof available at extra cost

Voltages:

110, 220 -50Hz AC

24, 120, 240, 480 -60Hz AC

6, 12, 24, 120, 240 - DC

Others available at extra cost

Max. operating pressure differential: 200 psi

Coil:

Insulation molded Class F

Watts AC 6

AC Volt Amps Inrush 30

AC Volt Amps Holding 16

Watts DC 10.6

Manual operator available at extra cost.

cULus Listed: 3" - 12"

*Optional material available for Seawater Service

When Ordering, Please Specify

1. Catalog No. 134-61
2. Valve Size
3. Pattern - Globe or Angle
4. Pressure Class
5. Threaded, Flanged or Grooved
6. Material Desired
7. Energized or De-energized to Open Main Valve
8. Solenoid Enclosure, Voltage & Hertz
9. When Vertically Installed



134-61 (R-03/2021)

CLA-VAL

1701 Placentia Avenue • Costa Mesa CA 92627

800-942-6326 • Web Site: www.cla-val.com • E-mail: info@cla-val.com

CLA-VAL CANADA

4687 Christie Drive
Beamsville, Ontario
Canada L0R 1B4
Phone: 905-563-4963
www.cla-val.com
E-mail: sales@cla-val.ca

CLA-VAL EUROPE

Chemin des Mésanges 1
CH-1032 Romanel/
Lausanne, Switzerland
Phone: 41-21-643-15-55
www.cla-val.ch
E-mail: cla-val@cla-val.ch

CLA-VAL UK

Dainton House, Goods Station Road
Turbridge Wells
Kent TN11 2 DH England
Phone: 44-1892-514-400
www.cla-val.ch
E-mail: info@cla-val.ch

CLA-VAL FRANCE

Porte du Grand Lyon 1
ZAC du Champ du Pérrier
France - 01700 Neyron
Phone: 33-4-72-25-92-93
www.cla-val.ch
E-mail: cla-val@cla-val.ch

CLA-VAL ASIA PACIFIC

45 Kennaway Road
Woolston, Christchurch, 8023
New Zealand
Phone: 64-39644860
www.cla-valpacific.com
E-mail: info@cla-valpacific.com