



Series 582

Two-Door Wafer Check Valve



**Meets the Federal
Mandate Limiting Lead
in Drinking Water**

SPECIFICATIONS

The two-door wafer check valve shall be compact wafer design to fit between ANSI flanges. The check valve doors shall be spring-loaded closed, by means of one or more heavy-duty stainless steel torsion springs. Flow shall cause the doors to open and upon pump shut down, the torsion spring will shut the doors, before reverse flow starts, for non-slam closure.

Seating shall be resilient Buna-N®, watertight and molded to the body. Valves 10" and larger shall be supplied with an eye bolt for lifting. The valve shall be a Cla-Val Series 582 Valves sizes 2" - 6" with alignment grooves for mounting between 150 or 300 lb. flanges. Valves sizes 8" - 36" inches will be wafer style to be mounted between 150 lb. flanges.

- **Low Head Loss**
- **Resilient Seat**
- **Non-Slam Closure**
- **Stabilizer Spheres Prevent Vibration Wear**

The Cla-Val Series 582 Two-Door Wafer Check Valve has torsion springs that force the two doors to shut before flow reversal, reducing the water hammer potential that normally occurs with single-door swing check valves. To help reduce water hammer, the two-door design also reduces the travel distance from open to shutoff for a quicker response. Extremely short in lay length, the valve is both a compact and economical solution. Two-Door Wafer Check Valves are available in sizes 2" to 36". Valve sizes 2" - 6" are dual rated to 150 and 300 pressure classes. Valve sizes 8" - 36" are rated to 150 pressure class.

Although lighter in weight than globe style swing check valves, Cla-Val Two-Door Wafer Check Valves are designed for heavy-duty applications. For ease of installation, valves 10" and larger are supplied with a tapped hole for installing a lifting eye bolt.

Materials

Valve Body:

Ductile Iron - ASTM 536 65-45-12

Doors:

Aluminum Bronze ASTM B148

Disc & Seat:

Stainless Steel

Spring:

Stainless Steel

Note: Standard offering is two-part epoxy coating interior and exterior

**Lug pattern available -
consult factory**

Flow in Gallons Per Minute

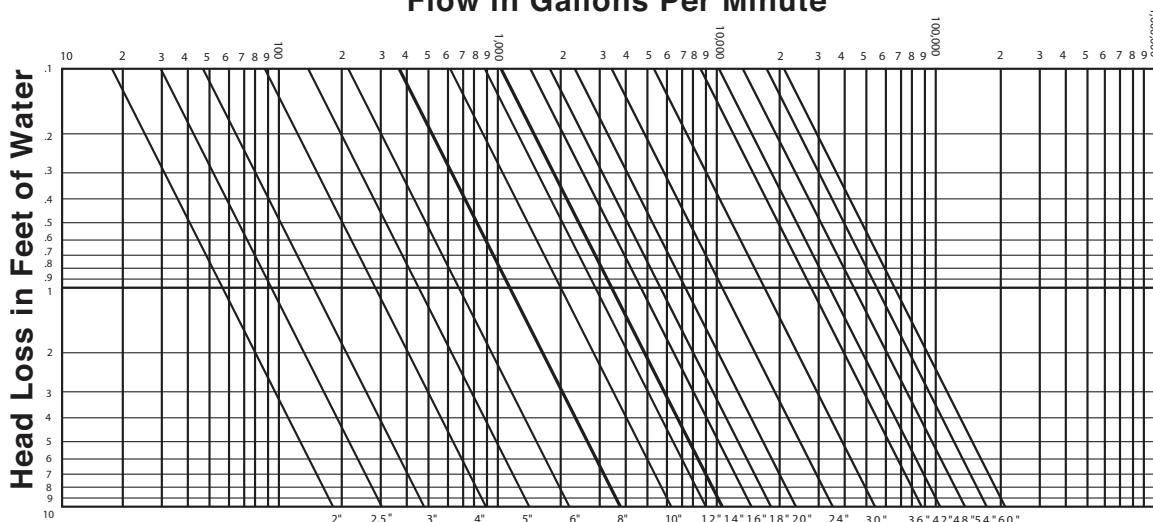

582 Series - Two-Door Wafer Check Valve

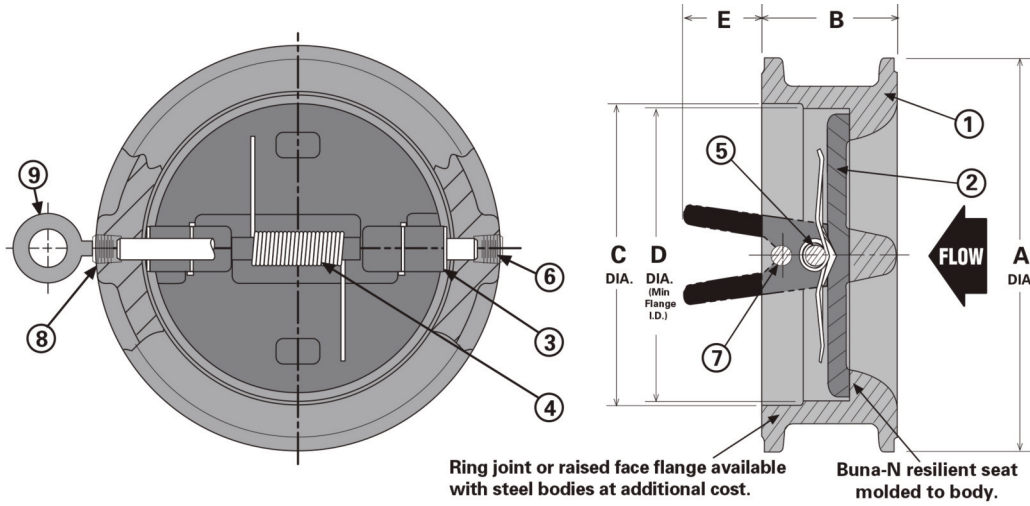

Size	Class	A	B	C	D	E	Wt.	
2" 50	125	4" 102	2.125" 54	2.563" 65	1.875" 48	.188" 5	5 2	
		4" 102	2.375" 60	2.563" 65	1" 25	—	6 3	
	250	4.25" 108	2.125" 54	2.563" 65	1.875" 48	.188" 5	8 4	
		4.25" 108	2.375" 60	2.563" 65	1" 25	—	8 4	
	2.5" 65	125	4.75" 121	2.375" 60	3.125" 79	2.375" 60	.375" 10	8 4
			4.75" 121	2.625" 67	3.125" 79	2" 51	.25" 6	8 4
250		5" 127	2.375" 60	3.125" 79	2.375" 60	.375" 10	11 5	
		5" 127	2.625" 67	3.125" 79	2" 51	.25" 6	12 5	
3" 80	125	5.25" 133	2.625" 67	3.5" 89	3" 76	.5" 13	10 5	
		5.25" 133	2.875" 73	3.5" 89	2.75" 70	.25" 6	11 5	
	250	5.75" 146	2.625" 67	3.5" 89	3" 76	.5" 13	15 7	
		5.75" 146	2.875" 73	3.5" 89	2.75" 70	.25" 6	16 7	
4" 100	125	6.75" 171	2.625" 67	4.5" 114	4.375" 111	1.125" 29	12 5	
		6.75" 171	2.875" 73	4.5" 114	4" 102	.875" 22	14 6	
	250	7" 178	2.625" 67	4.5" 114	4.375" 111	1.125" 29	20 9	
		7" 178	2.875" 73	4.5" 114	4" 102	.875" 22	22 10	
5" 125	125-150	6.75" 171	2.625" 67	4.5" 114	4.375" 111	1.125" 29	30 14	
	250-300	8.375" 213	3.25" 83	5.563" 141	5" 127	1.25" 32	33 15	
6" 150	125	8.625" 219	3.75" 95	6.625" 168	6" 152	1.5" 38	30 14	
		8.625" 219	3.875" 98	6.625" 168	5.875" 149	1.375" 35	32 15	
	250	9.75" 248	3.75" 95	6.625" 168	6" 152	1.5" 38	40 18	
		9.75" 248	3.875" 98	6.625" 168	5.875" 149	1.375" 35	44 20	
8" 200	125-150	10.875" 276	5" 127	8.75" 222	7.75" 197	1.5" 38	52 24	
		250-300	12" 305	5" 127	8.75" 222	7.75" 197	1.5" 38	70 32
	125	13.25" 337	5.5" 140	10.75" 273	10" 254	2.625" 67	63 29	
		150	13.25" 337	5.75" 146	10.75" 273	9.75" 248	2.375" 60	100 45
250	14.125" 359	5.5" 140	10.75" 273	10" 254	2.625" 67	110 50		
	300	14.125" 359	5.75" 146	10.75" 273	9.75" 248	2.375" 60	115 52	

Inch
Millimeter

lbs.
kg

Note: Two or more springs used on sizes 14" (350mm) & larger.

Size	Class	A	B	C	D	E	Wt.
12" 300	125-150	16" 406	7.125" 181	12.75" 324	10.875" 276	2.625" 67	150 68
		250-300	16.5" 419	7.125" 181	12.75" 324	10.875" 276	2.625" 67
14" 350	125-150	17.625" 448	7.25" 184	14" 356	13" 330	3.5" 89	220 100
		250-300	19" 483	8.75" 222	14" 356	12" 305	2" 51
16" 400	125-150	20.125" 511	7.5" 191	16" 406	15" 381	4.25" 108	275 125
		250-300	21.5" 546	9.125" 232	16" 406	14" 356	2.625" 67
18" 450	125-150	21.5" 546	8" 203	18" 457	17" 432	4.875" 124	300 136
		250-300	23.375" 594	10.375" 264	18" 457	16" 406	2.5" 64
20" 500	125	23.25" 591	8.375" 213	20" 508	18" 457	6.75" 171	325 147
		150	23.75" 603	8.625" 219	20" 508	18" 457	6.5" 165
	250	25.625" 651	11.5" 292	20" 508	17" 432	3.625" 92	450 204
		300	25.625" 651	11.5" 292	20" 508	17" 432	3.625" 92
24" 600	125-150	28.125" 714	8.75" 222	24" 610	22.625" 575	8.875" 225	700 318
	250-300	30.375" 772	12.5" 318	24" 610	21" 533	5.125" 130	1135 515
30" 750	125-150	34.625" 879	12" 305	30" 762	28.625" 727	11.125" 283	1100 499
	250-300	37.25" 946	14.5" 368	30" 762	27.375" 695	8.625" 219	1400 635
36" 900	125-150	41.125" 1045	14.5" 368	36" 914	34" 864	12.375" 314	1520 689
	250-300	43.75" 1111	18.875" 479	36" 914	33" 838	8" 203	1900 862
42" 1100	125-150	47.875" 1216	17" 432	42" 1067	40.375" 1026	15.125" 384	3000 1361
	250-300	50.625" 1286	22.375" 568	42" 1067	39" 991	9.75" 248	3500 1588
48" 1200	125-150	54.375" 1381	20.625" 524	48" 1219	46.625" 1184	16.875" 429	4500 2041
	250-300	58.625" 1489	24.75" 629	48" 1219	45.625" 1159	12.75" 324	5500 2495
54" 1400	125-150	60.875" 1546	21.25" 540	54" 1372	52.875" 1343	19.625" 498	6700 3039
		1500	67.25" 1708	25" 635	59.5" 1511	50" 1270	16" 406

Inch
Millimeter

Notes

Install the Cla-Val Series 582 Two-Door Wafer Check Valve between two standard flanges in the horizontal or vertical, flow up position.

For horizontal flow, this valve must be installed with disc hinge pin in the vertical position to ensure proper operation.