



— MODEL — **850-20**

800 Series (Tubular Diaphragm Valve)

# Seawater Relief Valve



- Low Head Loss
- One Spring for all Pressure Ranges between 30 and 200 PSIG
- Cast Steel Construction
- Pressure Excursions Do Not Exceed 3% of Set Pressure
- Fusion Coated Epoxy Inside and Out
- Anti-Cavitation Design
- Nickel Aluminum Bronze Construction Option (Alloy C95800)
- Duplex Stainless Steel Construction Option (Alloy 2205)
- Low Maintenance
- Simple and Reliable Operation
- 1-Year Warranty

The Cla-Val Model 850-20 Seawater Relief Valve is a pressure-operated, in-line axial valve. A tube diaphragm actuates the valve, which is comprised of three major components: 1) Tube 2) Barrier and 3) Body. There is only one moving part in the valve — the tube diaphragm. There are no shafts, packing, stem guides or springs.

The tube diaphragm is a one piece, homogeneous nitrile rubber part which is extremely durable. The ends of the tube are thick solid rubber, designed to fit between mating flanges. This design eliminates the possibility of cutting the tube diaphragm due to over tightening or piping misalignment during installation.

The tube forms a drip tight seal around the barrier when the pressure is equalized between the valve inlet and the control chamber. When pressure is removed from the control chamber, the valve is open. The minimum recommended operating pressure is 40 P.S.I. of inlet pressure.

## Principle of Operation

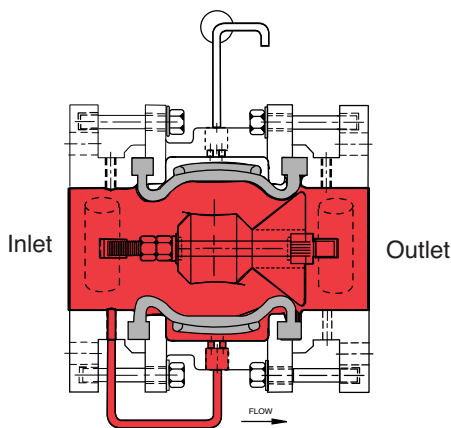

**Full Open Operation**

The valve opens when pilot set pressure is reached and pressure in the control chamber is relieved.

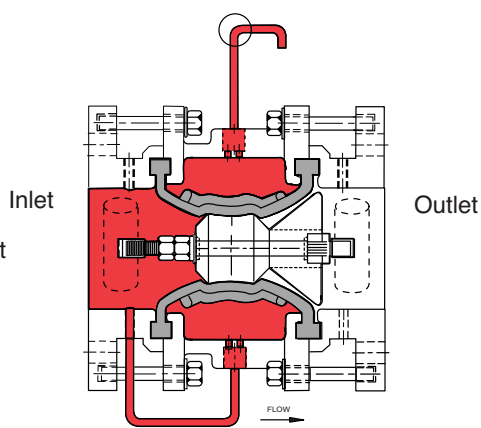

**Tight Closing Operation**

Water pressure (equal to inlet pressure) from valve inlet or from upstream of valve is applied to the control chamber. Valve closes bubble tight.

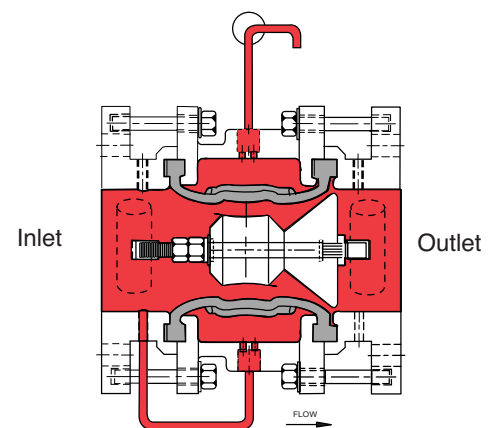

**Modulating Action**

The valve tube diaphragm holds any intermediate position when a quantity of water is exhausted from the control chamber via the pilot. The quantity of water in the control chamber is established by the "set pressure" of the pilot.

The control chamber is filled or exhausted to atmosphere, maintaining "set pressure."

## Dimensions

## Model 850-20

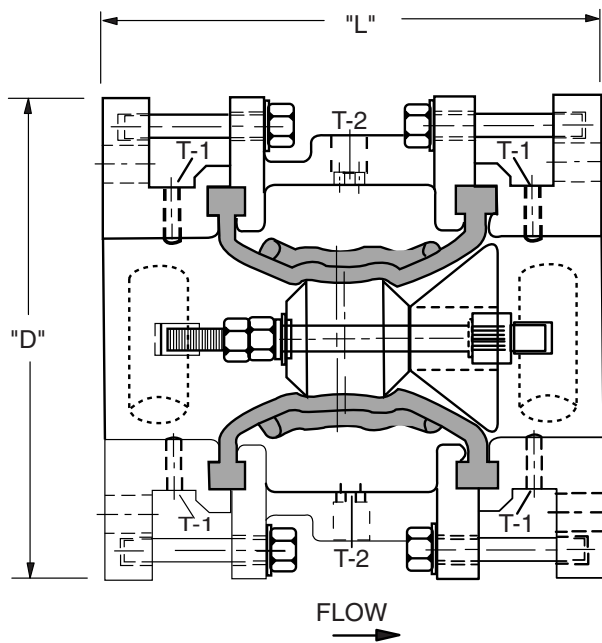

Valve Size (Inches)	3	4	6	8	10
L	8.75	9.75	10.75	11.75	14.00
D	7.5	9.5	11.75	14.00	16.44
T-1/T-2 (NPT)	1/4	1/4	3/8	3/8	1/2
Approx. Wt. (Lbs.)	67	99	135	185	270

Valve Size (mm)	80	100	150	200	250
L	222	248	273	299	356
D	191	241	299	356	418
T-1/T-2 (NPT)	1/4	1/4	3/8	3/8	1/2
Approx. Wt. (kgs.)	30	45	61	84	123

FLOW FACTORS		
SIZE (IN)	CV (gpm)	KV
3"	160	36.4
4"	340	77.3
6"	885	201
8"	1667	379
*10"	2424	550

### Valve Capacity\*

\* CALCULATED

Valve Sizes	3"	4"	6"	8"	10"
NFPA 20 Maximum Recommended GPM	500	1000	2500	5000	11000

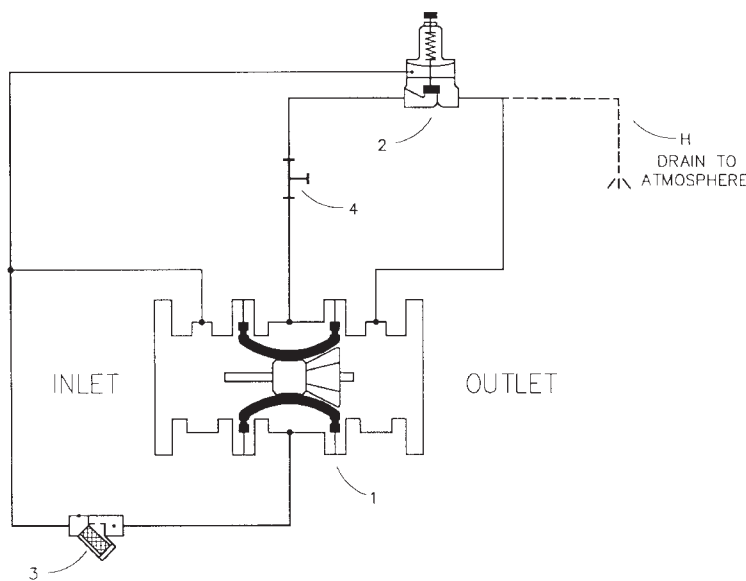

### MAIN VALVE

Ends: Flanged ANSI B16.5 (150lb Class)  
 Body: Cast Steel (ASTM A216 WCB)  
 Tube Diaphragm: Nitrile Rubber  
 Barrier: Urethane  
 Bolts: 316 SS  
 Pressure: 250 psig (17.24 BAR)  
 Temp. Range: 32° F to 180° F (0° C to 82.2° C)

### MAIN VALVE OPTIONS

Body: Nickel Aluminum Bronze (Alloy C95800) or Duplex SS (Alloy 2205)

### PILOT VALVE

All Parts: Bronze / Monel  
 O-Rings: Nitrile Rubber  
 Control: Controls Pressure Excursions within 3% of Set Point  
 Spring Range: 30 to 200 PSIG  
 Operation: Normally Closed; Opens at Set Pressure; Modulates

### PILOT VALVE OPTIONS

All Wetted Parts: Monel (Alloy 400)

## 850-20 Basic Components

### Item Description

- 100-43 TDV Main Valve
- CRL Pressure Relief Control
- X44A Strainer and Orifice Assembly
- 4" Gauge Connection

Cla-Val 800 Series Control Valves operate with maximum efficiency when mounted in horizontal or vertical piping. Adequate space above and around the valve for service personnel should be considered essential. A regular maintenance program should be established based on the specific application data. However, we recommend a thorough inspection be done at least once a year. Consult factory for specific recommendations.



E-850-20 (R-03/2021)

## CLA-VAL

1701 Placentia Avenue • Costa Mesa, Ca 92627  
 800-942-6326 • Web Site: [www.cla-val.com](http://www.cla-val.com) • E-mail: [info@cla-val.com](mailto:info@cla-val.com)

**CLA-VAL CANADA**  
 4687 Christie Drive  
 Beamsville, Ontario  
 Canada L0R 1B4  
 Phone: 905-563-4963  
 Fax: 905-563-4040  
 E-mail: [sales@cla-val.ca](mailto:sales@cla-val.ca)

**CLA-VAL EUROPE**  
 Chemin des Mésanges 1  
 CH-1032 Romanel/  
 Lausanne, Switzerland  
 Phone: 41-21-643-15-55  
[www.cla-val.ch](http://www.cla-val.ch)  
 E-mail: [info@cla-val.ch](mailto:info@cla-val.ch)

**CLA-VAL UK**  
 Dainton House, Goods Station Road  
 Tunbridge Wells  
 Kent TN11 2 DH England  
 Phone: 44-1892-514-400  
[www.cla-val.ch](http://www.cla-val.ch)  
 E-mail: [info@cla-val.ch](mailto:info@cla-val.ch)

**CLA-VAL FRANCE**  
 Porte du Grand Lyon 1  
 ZAC du Champ du Pérrier  
 France - 01700 Neyron  
 Phone: 33-4-72-25-92-93  
[www.cla-val.ch](http://www.cla-val.ch)  
 E-mail: [info@cla-val.ch](mailto:info@cla-val.ch)

**CLA-VAL ASIA PACIFIC**  
 45 Kennaway Road  
 Woolston, Christchurch, 8023  
 New Zealand  
 Phone: 64-39644860  
[www.cla-valpacific.com](http://www.cla-valpacific.com)  
 E-mail: [info@cla-valpacific.com](mailto:info@cla-valpacific.com)