



# MODEL 90-FS-PRV-25

## Factory Set (2-1/2-inch) Pressure Reducing Valve



- Sensitive and Accurate Pressure Control
- Complies with NFPA for Class I Systems
- UL/ ULC Listed

The Cla-Val 2 1/2" Model 90-FS-PRV-25 Is a UL/ULC listed Factory Set pressure reducing valve which can be used as a standpipe valve, floor control valve and a checking device.

The valve is in compliance with NFPA for Class I systems and can handle "Flow" and "No Flow" conditions and rated for systems up to a maximum inlet pressure of 400 psi.

A brass body is standard but can be supplied with a chrome plate finish. An optional Supervisory Switch is available at an additional charge.

### End Connection Options

- Female NPT x Male Hose - Angle - (FM)
- Female NPT x Female NPT- Straight - (SF)
- Groove x Groove - Angle - (GG)
- Groove x Groove -Straight -(SG)
- Groove x Male Outlet -Angle - (GM)

### Dimensions

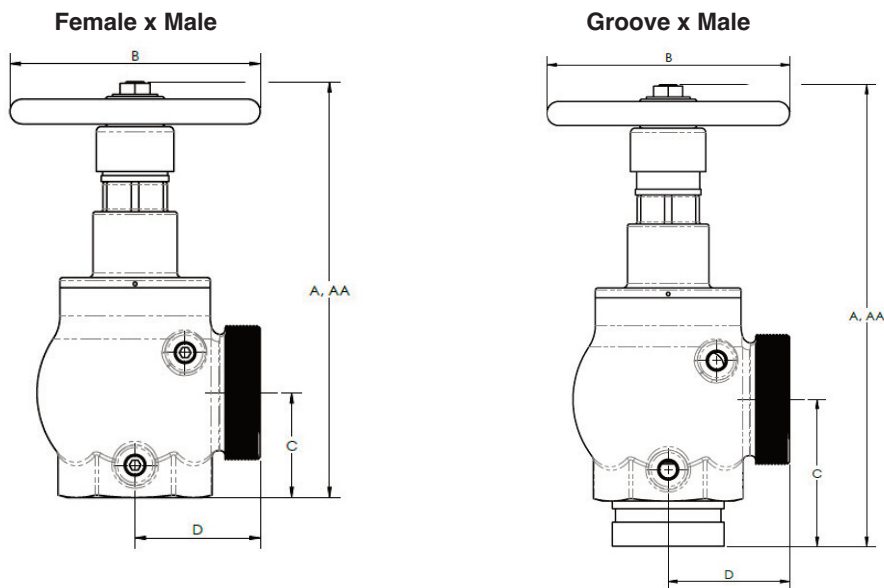

		A	AA	BØ	C	D
2.5 Factory Set	Female x Male	10-1/2" (264.1)	10-3/4" (274.1)	6-1/4" (158.8)	2-3/4" (66.7)	3-1/4" (79.4)
	Groove x Male	12" (302.5)	12-1/4" (312.5)	6-1/4" (158.8)	3-3/4" (96.3)	3-1/4" (79.4)