CLA-VAL

AUTOMATIC CONTROL VALVES

90-48/690-48

Place this manual with personnel responsible
for maintenance of this valve



Installation



Operation

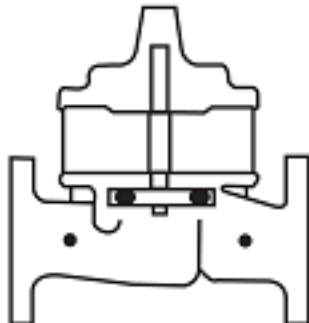

Maintenance



CLA-VAL • 1701 Placentia Avenue • Costa Mesa, CA 92627 • (949) 722-4800 • info@cla-val.com
CLA-VAL CANADA LTD. • 4687 Christie Drive • Beamsville, Ontario, LOR 1B4 Canada • (905) 563-4963

www.cla-val.com • info@cla-val.com



NEWPORT BEACH, CALIFORNIA

CATALOG NO.
90-48/690-48

DRAWING NO.
20251

REV
E

TYPE OF VALVE AND MAIN FEATURES

PRESSURE REDUCING VALVE
WITH LOW FLOW PRESSURE REDUCING BY-PASS

DESIGN

DRAWN	IC	8-4-89
CHK'D	JH	8-11-89
APVD	CH	8-11-89

----- NOT FURNISHED BY CLA-VAL CO. ----- OPTIONAL FEATURES

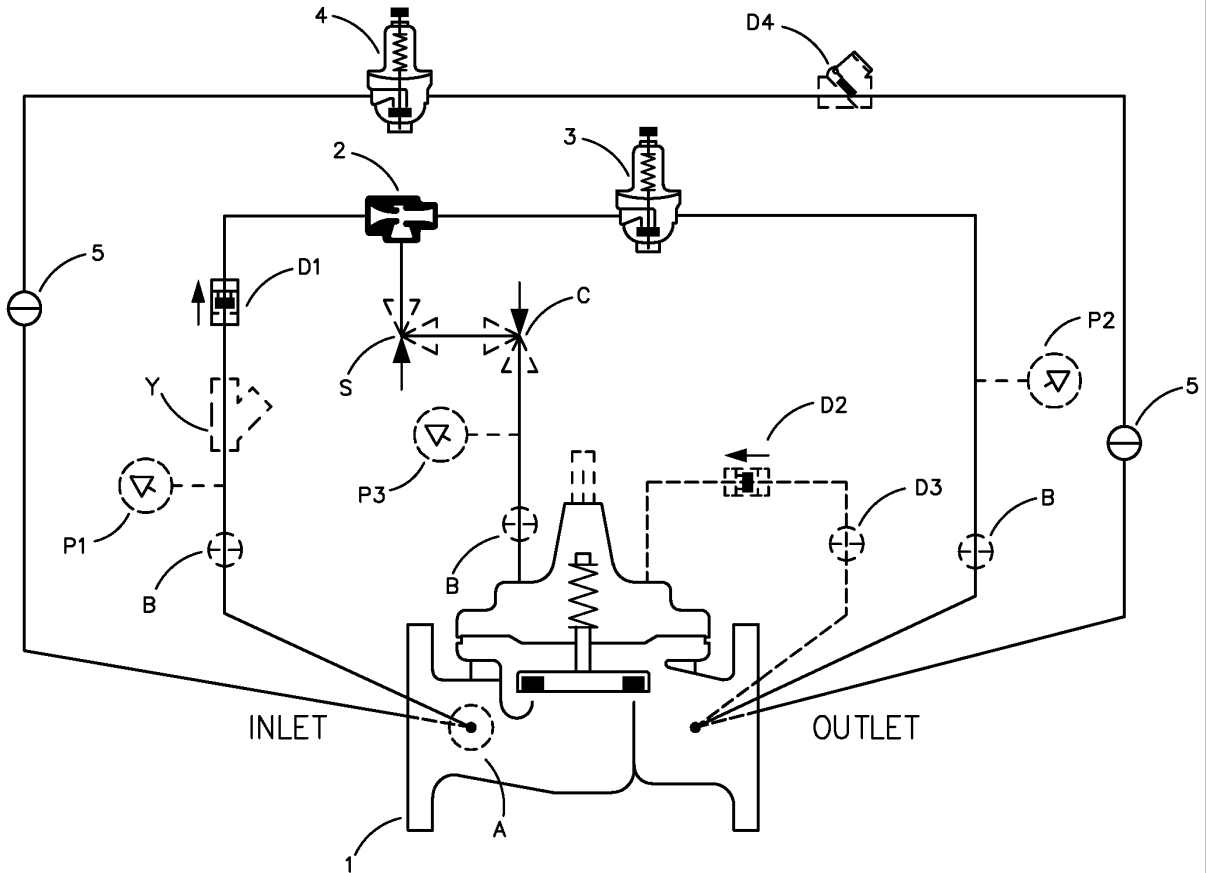

ITEM NO.	BASIC COMPONENTS	QTY
1	100-01 HYTROL (90-48) MAIN VALVE	1
	100-20 HYTROL (690-48) MAIN VALVE	
2	X47A EJECTOR	1
3	CRD PRESSURE REDUCING CONTROL	1
4	CRDL PRESSURE REDUCING CONTROL	1
5	CK2 COCK (ISOLATION VALVE)	2

OPTIONAL FEATURE SUFFIX		ADDED TO CATALOG NUMBER	
A	X46A FLOW CLEAN STRAINER	1	V X101 VALVE POSITION INDICATOR 1
B	CK2 COCK (ISOLATION VALVE)	3	Y X43 "Y" STRAINER 1
C	CV FLOW CONTROL (CLOSING)	1	
D	CHECK VALVES WITH COCK	1	
P	X141 PRESSURE GAUGE	3	
S	CV FLOW CONTROL (OPENING)	1	

4-9-15
 AV
 CHANGED ITEM (4) TO CRDL; REMOVED SIZE CALLOUT TO ITEM (1) (ECO 25021)
 E

CAD REVISION RECORD - DO NOT REVISE MANUALLY
 DESCRIPTION
 BY DATE
 AK 1-27-10
 A-C SEE REVISION FILE
 D ADDED OPTIONAL FEATURES P & V (ECO 21821)

THIS DRAWING IS THE PROPERTY OF CLA-VAL CO. AND SAME AND COPIES MADE THEREOF, IF ANY, SHALL BE RETURNED TO IT UPON DEMAND. DELIVERY AND DISCLOSURE HEREOF ARE MADE SOLELY UPON CONDITION THAT THE SAME SHALL NOT BE USED, COPIED OR REPRODUCED, NOR SHALL THE SUBJECT HEREOF BE DISCLOSED IN ANY MANNER TO ANYONE FOR ANY PURPOSE, EXCEPT AS HEREIN AUTHORIZED, WITHOUT PRIOR WRITTEN APPROVAL OF CLA-VAL CO. THIS DRAWING IS SUBMITTED CONFIDENTIALLY AND MAY NOT BE USED IN THE MANUFACTURE OF ANY MATERIAL OR PRODUCT OTHER THAN SUCH MATERIALS AND PRODUCTS FURNISHED TO CLA-VAL CO. WHETHER OR NOT THE EQUIPMENT OR INFORMATION SHOWN HEREON IS PATENTED OR OTHERWISE PROTECTED, FULL TITLE AND COPYRIGHTS, IF ANY, IN AND TO THIS DRAWING AND/OR INFORMATION DELIVERED OR SUBMITTED ARE FULLY RESERVED BY CLA-VAL CO.®



NEWPORT BEACH, CALIFORNIA

CATALOG NO.

90-48/690-48

DRAWING NO.

20251

REV

E

TYPE OF VALVE AND MAIN FEATURES

PRESSURE REDUCING VALVE
WITH LOW FLOW PRESSURE REDUCING BY-PASS

DESIGN

DRAWN	IC	8-4-89
CHK'D	JH	8-11-89
AP'VD	CH	8-11-89

OPERATING DATA

I. PRESSURE REDUCING FEATURE:

PRESSURE REDUCING CONTROL (3) IS A NORMALLY OPEN CONTROL THAT SENSES MAIN VALVE OUTLET PRESSURE CHANGES. AN INCREASE IN OUTLET PRESSURE TENDS TO CLOSE CONTROL (3) AND A DECREASE IN OUTLET PRESSURE TENDS TO OPEN CONTROL (3). THIS CAUSES MAIN VALVE COVER PRESSURE TO VARY AND THE MAIN VALVE MODULATES (OPENS AND CLOSES) MAINTAINING A RELATIVELY CONSTANT OUTLET PRESSURE. PRESSURE REDUCING CONTROL (3) ADJUSTMENT: TURN THE ADJUSTING SCREW CLOCKWISE TO INCREASE THE SETTING.

II. LOW-FLOW PRESSURE REDUCING BYPASS FEATURE:

PRESSURE REDUCING CONTROL (4) IS A NORMALLY OPEN, DIRECT ACTING CONTROL THAT RESPONDS TO MAIN VALVE OUTLET PRESSURE CHANGES. AN INCREASE IN OUTLET PRESSURE CLOSES CONTROL (4) AND A DECREASE IN OUTLET PRESSURE OPENS CONTROL (4). WHEN CONTROL (3) CLOSES, CONTROL (4) REMAINS OPEN. THIS PERMITS THE HIGHER INLET PRESSURE TO FLOW THROUGH CONTROL (4), BYPASSING THE MAIN VALVE UNTIL DOWNSTREAM PRESSURE INCREASES TO THE SET POINT OF CONTROL (4) AND CONTROL (4) CLOSES. PRESSURE REDUCING CONTROL (4) ADJUSTMENT: PRESSURE REDUCING CONTROL (4) MUST BE SET HIGHER THAN PRESSURE REDUCING CONTROL (3). TURN THE ADJUSTING SCREW CLOCKWISE TO INCREASE THE SETTING.

III. OPTIONAL FEATURE OPERATING DATA:

SUFFIX A (FLOW CLEAN STRAINER)

A SELF-CLEANING STRAINER IS INSTALLED IN THE MAIN VALVE INLET BODY BOSS WHICH PROTECTS THE PILOT SYSTEM FROM FOREIGN PARTICLES.

SUFFIX B (ISOLATION VALVES)

CK2 COCKS (B) ARE USED TO ISOLATE THE PILOT SYSTEM FROM MAIN LINE PRESSURE. THESE VALVES MUST BE OPEN DURING NORMAL OPERATION.

SUFFIX C (CLOSING SPEED CONTROL)

FLOW CONTROL (C) CONTROLS THE CLOSING SPEED OF THE MAIN VALVE. TURN THE ADJUSTING STEM CLOCKWISE TO MAKE THE MAIN VALVE CLOSE SLOWER.

SUFFIX D (CHECK VALVES WITH COCK):

WHEN OUTLET PRESSURE IS HIGHER THAN INLET PRESSURE, CHECK VALVE (D2) OPENS AND (D1) & (D4) CLOSE. THIS DIRECTS THE HIGHER OUTLET PRESSURE INTO THE MAIN VALVE COVER AND THE MAIN VALVE CLOSES.

CAD REVISION RECORD - DO NOT REVISE MANUALLY

DESCRIPTION

BY

DATE

LTR

SEE SHEET 1



NEWPORT BEACH, CALIFORNIA

CATALOG NO.

90-48/690-48

DRAWING NO.

20251

REV

E

TYPE OF VALVE AND MAIN FEATURES

PRESSURE REDUCING VALVE
WITH LOW FLOW PRESSURE REDUCING BY-PASS

DESIGN

DRAWN	IC	8-4-89
CHK'D	JH	8-11-89
AP'VD	CH	8-11-89

OPERATING DATA-CONTINUED

SUFFIX P (PRESSURE GAUGE):

PRESSURE GAUGES (P) PROVIDE PRESSURE READING IN THE INLET, OUTLET AND COVER CONNECTIONS.

SUFFIX S (OPENING SPEED CONTROL)

FLOW CONTROL (S) CONTROLS THE OPENING SPEED OF THE MAIN VALVE. TURN THE ADJUSTING STEM CLOCKWISE TO MAKE THE MAIN VALVE OPEN SLOWER.

SUFFIX V (VALVE POSITION INDICATOR):

VALVE POSITION INDICATOR (V) DISPLAYS A VISUAL POSITION OF THE MAIN VALVE STEM.

SUFFIX Y (Y-STRAINER)

A Y-PATTERN STRAINER IS INSTALLED IN THE PILOT SUPPLY LINE TO PROTECT THE PILOT SYSTEM FROM FOREIGN PARTICLES. THE STRAINER SCREEN MUST BE CLEANED PERIODICALLY.

IV. CHECK LIST FOR PROPER OPERATION:

- () SYSTEM VALVES OPEN UPSTREAM AND DOWNSTREAM.
- () AIR REMOVED FROM THE MAIN VALVE COVER AND PILOT SYSTEM AT ALL HIGH POINTS.
- () CK2 COCKS (B) & (D3) OPEN (OPTIONAL FEATURE).
- () PERIODIC CLEANING OF STRAINER (Y) IS RECOMMENDED (OPTIONAL FEATURE).
- () CK2 COCKS (5) OPEN DURING NORMAL OPERATION.
- () CV FLOW CONTROLS (C) & (S) OPEN AT LEAST 4 TURNS (OPTIONAL FEATURE).

CAD REVISION RECORD - DO NOT REVISE MANUALLY

DESCRIPTION

DATE

BY

LTR

SEE SHEET 1



Recommended Inspections

Cla-Val recommends that an inspection be performed on our products annually. The inspection should include both a visual and functional test of the main valve/component and the pilot system. The inspection ensures that no damage or premature wear occurred due to velocity, pressure, or foreign matter within the fluid that may have exceeded the valve's design. Please consult the maintenance manual for specific information on the model. Manuals are available for download at Cla-Val.com, as well as contact information for a company representative.

Accurate record-keeping is a best practice for any preventative maintenance program, and Cla-Val strongly recommends this action through an asset management program. Cla-Val provides a free asset management tool, Link2Valves [Link2Valves - Cla-Val \(cla-val.com\)](http://Link2Valves - Cla-Val (cla-val.com)), to assist in preventative maintenance record-keeping and scheduling.

This drawing is the property of CLA-VAL CO. and same and copies hereof shall be returned to CLA-VAL CO. upon demand. Safety and dimensions listed are made only upon condition that the user will follow proper operation and maintenance, and that the design herein be identical to the original as shown on the drawings, except on items indicated, without other written approval of CLA-VAL CO. This drawing is neither a contract nor a warranty and may not be used in the manufacture of any material or product other than those specifically and expressly authorized by CLA-VAL CO. Neither is it the obligation or intention of CLA-VAL CO. to assume or otherwise undertake, for the life and royalties, if any, to and to this drawing and/or alterations hereon or substituted or fully covered by CLA-VAL CO.

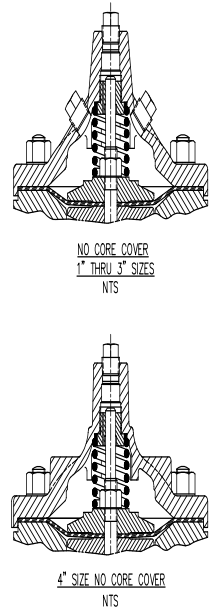
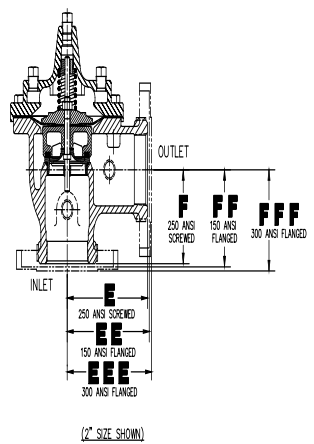
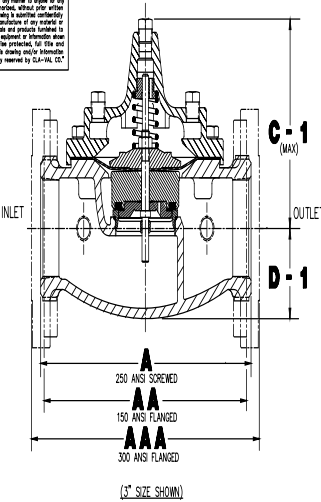

OLD STYLE BODY CONFIGURATIONS

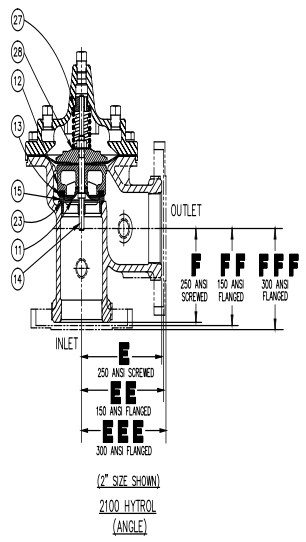
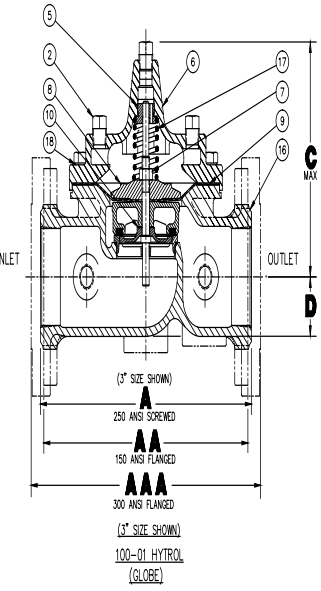
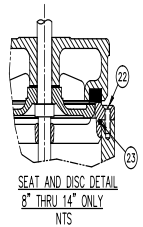
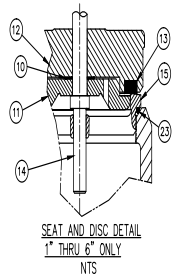
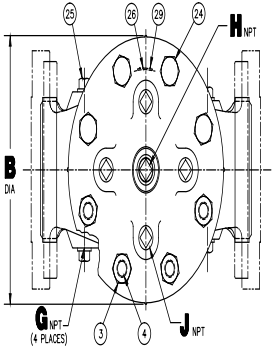

REVISIONS			
REV	DESCRIPTION	DATE	APPROVED
A	3" SIZE REVISION FILE		
E	REVISED A REVISION ON DIA; ADD DIM 4.00 & 4.25 ON VALVE SIZE 1 1/2" (ECC 1898)	10-18-98	AK
F	ADDED 1" SIZE SCREWED CONFIGURATION TO THE DWG (ECC 21834)	10-18-10	AK
G	DELETED 1" SIZE VALVE FROM DIMENSION TABLE, PARTS LIST, AND RELATED COVER BEARING DETAIL VIEW (ECC 21934)	6-16-10	PC
H	ADDED SHEET 2 (ECC 22323)	10-16-11	AK
J	ADDED WASHERS & REVISED STUD LENGTH ON 150-20 VALVES (ECC 23135)	07-18-12	MS
K	SP-E: ADDED VIEW OF BEARING HOUSING ASST FOR 30"; ADDED VIEW OF BOLT ON BEARING ON SEAT FOR 30"; UPDATED TABLE FOR 30" SIZE PER DRAWING 22868 (ECC 25001)	3-25-15	MS
L	ASSEMBLY DETAIL; ADDED DIAPHRAGM WASHER SEAL DETAIL (ECC 25304)	09-18-15	RP
M	SHEET 1: SIZES FOR ITEM NO.'S 3 & 4 (STUD AND NUT) WAS 6" THRU 14" ONLY; SIZES FOR ITEM NO. 24 (BOLT) WAS 1" THRU 4" ONLY. (ECC 26536)	01-14-16	VL

VALVE SIZES	DIMENSION TABLE													
	1"	1 1/4"	1 1/2"	2"	2 1/2"	3"	4"	6"	8"	10"	12"	14"	F"	
A	7.25	7.25	7.25	9.38	11.00	12.50	-	-	-	-	-	-	-	
AA	-	-	8.50	9.38	11.00	12.00	15.00	20.00	25.38	29.75	34.00	39.00		
AAA	-	-	9.00	10.00	11.62	13.25	15.62	21.00	26.38	31.12	35.50	40.50		
B DIA	5.62	5.62	5.62	6.62	8.00	9.12	11.50	15.75	20.00	23.62	28.00	32.75		
C MAX	5.50	5.50	5.50	6.50	7.56	8.19	10.62	13.38	16.00	-	-	-		
C-1 MAX	-	4.75	4.75	5.75	6.88	7.25	9.31	12.12	14.62	17.12	20.88	24.19		
D	1.12	1.12	1.12	1.50	1.69	2.06	3.19	4.31	5.31	-	-	-		
D-1	-	2.00	2.00	2.50	2.88	3.12	4.25	6.00	7.56	9.25	10.75	12.62		
E	3.25	3.25	3.25	4.75	5.50	6.25	-	-	-	-	-	-		
EE	-	-	4.00	4.75	5.50	6.00	7.50	10.00	12.89	14.88	17.00	19.50		
EEE	-	-	4.25	5.00	5.88	6.38	7.88	10.50	13.25	15.56	17.75	20.25		
F	1.88	1.88	1.88	3.25	4.00	4.50	-	-	-	-	-	-		
FF	-	-	4.00	3.25	4.00	4.00	5.00	6.00	8.00	8.62	13.75	14.88		
FFF	-	-	4.25	3.50	4.31	4.38	5.31	6.50	8.50	9.31	14.50	15.62		
G NPT	3/8"	3/8"	3/8"	3/8"	1/2"	1/2"	3/4"	3/4"	1"	1"	1"	1"		
H NPT	1/4"	1/4"	1/4"	1/2"	1/2"	1/2"	3/4"	3/4"	1"	1"	1-1/4"	1-1/2"		
J NPT	1/4"	1/4"	1/4"	3/8"	1/2"	1/2"	3/4"	3/4"	1"	1"	1"	1"		

* 3/8" NPT FOR NO CORE COVER

** USE ON PAINTED OR EPOXY-COATED VALVES ONLY
** RECOMMENDED SPARE PARTS

ITEM NO.	DESCRIPTION	QTY
29	SCREEN DRIVE	2
28	WASHER, SPRING, LOWER **	1
27	WASHER, SPRING, UPPER **	1
26	NAMEPLATE	1
25	PLUG, PIPE, BODY	A/R
24	BOLT, HEX HD. (1" THRU 6" ONLY)	A/R
23	O-RING, SEAT	1
22	SCREW, FLAT HD. (8" THRU 14" ONLY)	A/R
21		
20		
19		
18	WASHER, FLAT	A/R
17	SPRING	1
16	BODY	1
15	SEAT	1
14	STEM	1
13	DISC	1
12	RETAINER, DISC	1
11	GUIDE, DISC	1
10	WASHER, SPACER	2
9	DIAPHRAGM	1
8	WASHER, DIAPHRAGM	1
7	NUT, STEM	1
6	COVER	1
5	BEARING, COVER	1
4	STUD (8" THRU 14" ONLY)	A/R
3	NUT, HEX (8" THRU 14" ONLY)	A/R
2	PLUG, PIPE, COVER	A/R
1	PLUG, PIPE, CENTER COVER	1

UNLESS OTHERWISE SPECIFIED DIMENSIONS ARE IN INCHES
TOLERANCES ARE:
FRACTIONS DECIMALS ANGULAR
± 1/32 0.01 ± 0.001 ± 0.5°
MAX +.02 -.02
MIN +.02 -.02

CONTRACT NO. _____
DATE _____
REV _____
DATE _____
BY _____
CHK _____
DATE _____
APP'D _____
DATE _____

1" THRU 14"
100-01 & 2100 HYTROL

86184 90842

1/2 & NPTD INTRC SHEET 1 OF 2
M. 05-11-18

This drawing is the property of CIA-VAL CO. and same and copies must be returned if they shall be retained by a user thereof. Safety and instructions listed are made only upon condition that the user will follow all safety and instructions, and shall be responsible for the design in all cases. No part of this drawing is to be used in the construction of any machine or equipment after this drawing and parts have been approved by CIA-VAL CO. Washer or not the standard or alternative shall depend on purchase or otherwise indicated. For file and reference, if any, to and to this drawing only for alterations indicated or authorized on file received by CIA-VAL CO.

REVISIONS			
REV.	DESCRIPTION	DATE	APPROVED
REV. SHEET 1			

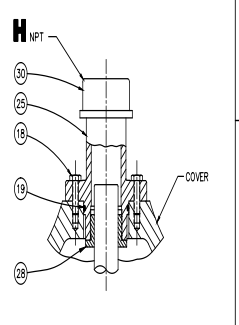
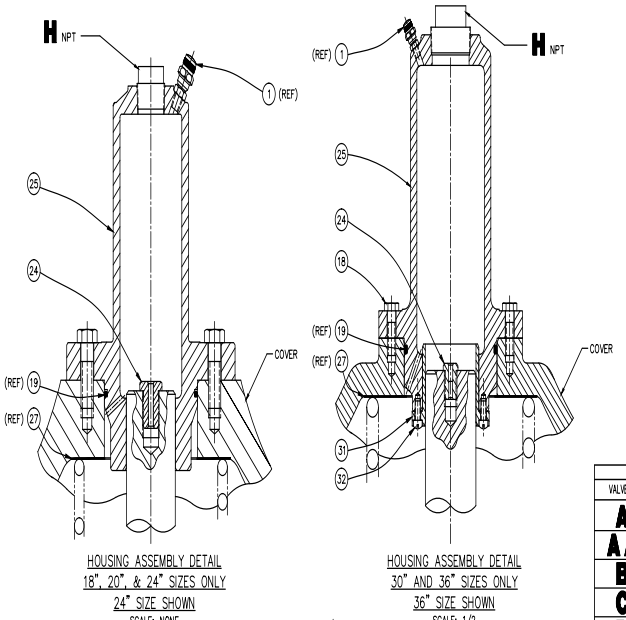
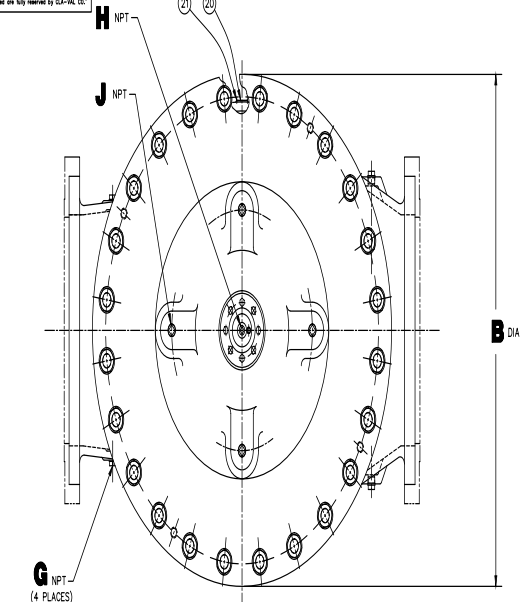

COVER BEARING/HOUSING DETAIL
16" SIZE ONLY
SCALE: NONE

HOUSING ASSEMBLY DETAIL
18", 20", & 24" SIZES ONLY
24" SIZE SHOWN
SCALE: NONE

HOUSING ASSEMBLY DETAIL
30" AND 36" SIZES ONLY
36" SIZE SHOWN
SCALE: 1/2

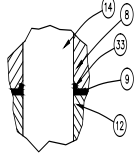

DIAPHRAGM WASHER SEAL DETAIL
30" SIZE ONLY
SCALE: 1/2

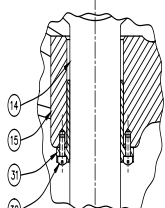

SEAT DETAIL
36" SIZE ONLY
SCALE: 1/2

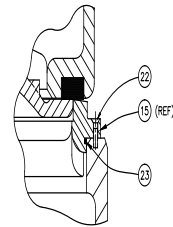

SEAT AND DISC DETAIL
SCALE: NONE

VALVE SIZES	DIMENSION TABLE					
	16"	18"	20"	24"	30"	36"
A	41.38	46.00	52.00	61.50	63.00	72.75
AA	35.50	47.64	53.62	63.25	64.50	-
B DIA	25.00	29.06	42.21	45.00	54.60	59.00
C MAX	15.50	12.95	15.00	17.75	21.31	24.50
D	20.81	-	-	30.75	-	-
E	21.62	-	-	31.62	-	-
EE	15.69	-	-	22.06	-	-
F	16.50	-	-	22.90	-	-
FF	-	15.00	16.50	19.25	22.50	28.50
G NPT	1"	1"	1"	1"	2"	2"
H NPT	2"	1"	1"	1"	2"	2"
J NPT	1"	1"	1"	1"	2"	2"
K	-	15.00	16.50	19.25	22.50	28.50

NOTES: UNLESS OTHERWISE SPECIFIED.

PLUG ITEM NO. 28 SCREW INTO ITEM NO. 8 DIAPHRAGM WASHER TO PRESERVE THREADS FOR FIELD SERVICE HANDLING.

** USE ON PAINTED OR EPOXY-COATED VALVES ONLY
** RECOMMENDED SPARE PARTS

ITEM NO.	DESCRIPTION	QTY
33	O-RING (30" ONLY)	1
32	SCREW FL. HD. (30" AND 36" ONLY)	A/R
31	INSERT COVER BEARING (30" AND 36" ONLY)	A/R
30	CAP. PIPE (16" ONLY)	1
29	WASHER FLAT	A/R
28	BEARING COVER (16" ONLY)	1
27	WASHER, SPRING, UPPER **	1
26	SCREW SOCKET CUP POINT	3
25	HOUSING	1
24	BUSHING, ADAPTER	1
23	O-RING, SEAT	1
22	SCREW FLAT HD.	A/R
21	SCREW DRIVE	2
20	MANEPLATE	1
19	O-RING	1
18	BOLT, HEX HD.	8
17	SPRING	1
16	BODY	1
15	SEAT	1
14	STEM	1
13	DISC	1
12	RETAINER, DISC	1
11	GUIDE, DISC	1
10	WASHER, SPACER	2
9	DIAPHRAGM	1
8	WASHER, DIAPHRAGM	1
7	NUT, STEM	1
6	COVER	1
5	WASHER, SPRING, LOWER **	1
4	STUD	A/R
3	NUT, HEX	A/R
2	PLUG, PIPE	A/R
1	VALVE, PURGE (18" - 36" ONLY)	1

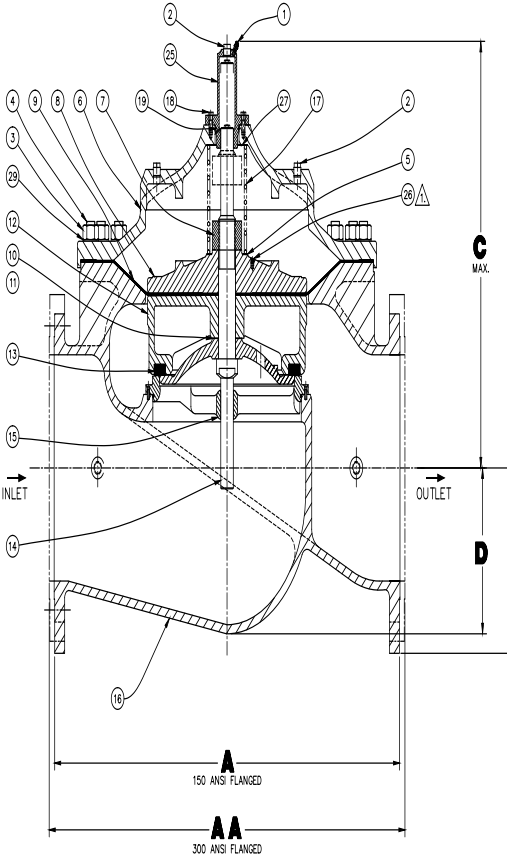

(24" SIZE SHOWN)
100-01 HYTROL
(GLOBE)

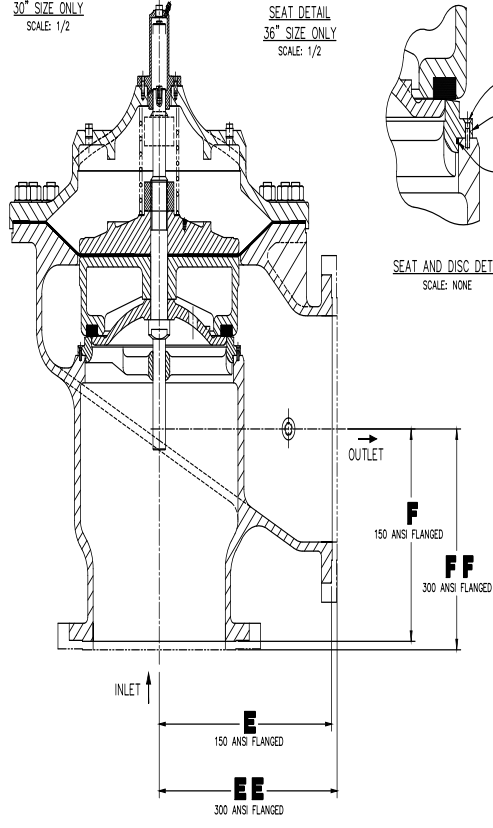

(24" SIZE SHOWN)
2100-01 HYTROL
(ANGLE)

UNLESS OTHERWISE SPECIFIED DIMENSIONS ARE IN INCHES
TOLERANCES ARE:
FINISH DIMENSIONS ANGULAR
± 0.01 0.01 0.03
MAX +0.02 -0.01
MIN +0.02 -0.01

SURFACE FINISH: 1/16"
BREAK CORNERS TO MAX
FILLET RADIUS 0.05

--DO NOT SCALE DRAWING--

CONTRACT NO. _____

APPROVE _____ DATE _____

DRAWN: WEP 11-9-82

CHECKED: KD 11-22-82

DATE CH 10-21-83

BY: M

16" THRU 36"
100-01 & 2100 HYTROL

86184 90842

SCALE: 1/16" & NOTED

DATE: 11-9-11-18

SHEET 2 OF 2



—MODEL— **100-01**
Hytrol Valve

Description

The Cla-Val Model 100-01 Hytrol Valve is a main valve for Cla-Val Automatic Control Valves. It is a hydraulically operated, diaphragm-actuated, globe or angle pattern valve.

This valve consists of three major components; body, diaphragm assembly, and cover. The diaphragm assembly is the only moving part. The diaphragm assembly uses a diaphragm of nylon fabric bonded with synthetic rubber. A synthetic rubber disc, contained on three and one half sides by a disc retainer and disc guide, forms a seal with the valve seat when pressure is applied above the diaphragm. The diaphragm assembly forms a sealed chamber in the upper portion of the valve, separating operating pressure from line pressure.

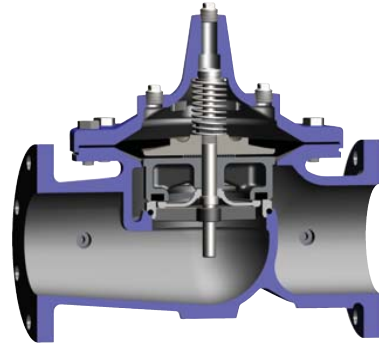

Installation

1. Before valve is installed, pipe lines should be flushed of all chips, scale and foreign matter.
2. It is recommended that either gate or block valves be installed on both ends of the 100-01 Hytrol Valve to facilitate isolating the valve for preventive maintenance and repairs.
3. Place the valve in the line with flow through the valve in the direction indicated on the inlet nameplate. (See "Flow Direction" Section)
Note: Valve can be installed in the vertical or horizontal position.
4. Allow sufficient room around valve to make adjustments and for disassembly.
5. Cla-Val 100-01 Hytrol Valves operate with maximum efficiency when mounted in horizontal piping with the cover UP, however, other positions are acceptable. Due to size and weight of the cover and internal components of 8 inch and larger valves, installation with the cover UP is advisable. This makes internal parts readily accessible for periodic inspection.

6. Caution must be taken in the installation of this valve to insure that galvanic and/or electrolytic action does not take place. The proper use of dielectric fittings and gaskets are required in all systems using dissimilar metals.
7. If a pilot control system is installed on the 100-01 Hytrol Valve, use care to prevent damage. If it is necessary to remove fittings or components, be sure they are kept clean and replaced exactly as they were.
8. After the valve is installed and the system is first pressurized, vent air from the cover chamber and pilot system tubing by loosening fittings at all high points.

Principles of Operation

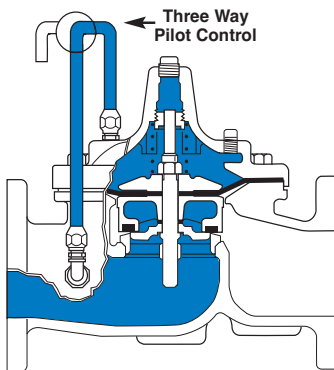

Tight Closing Operation

When pressure from the valve inlet (or an equivalent independent operating pressure) is applied to the diaphragm chamber the valve closes drip-tight.

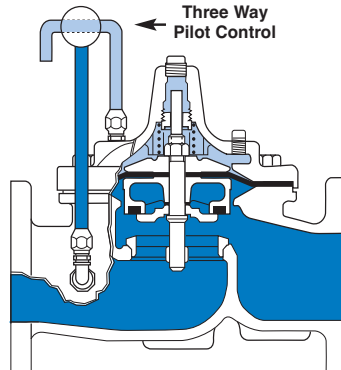

Full Open Operation

When pressure in diaphragm chamber is relieved to a zone of lower pressure (usually atmosphere) the line pressure (5 psi Min.) at the valve inlet opens the valve.

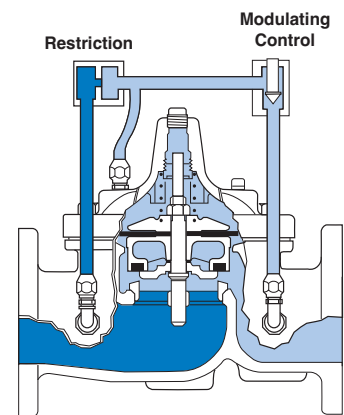

Modulating Action

Valve modulates when diaphragm pressure is held at an intermediate point between inlet and discharge pressure. With the use of a Cla-Val. "modulating control," which reacts to line pressure changes, the pressure above the diaphragm is varied, allowing the valve to throttle and compensate for the change.

Flow Direction

The flow through the 100-01 Hytrol Valve can be in one of two directions. When flow is “up-and-over the seat,” it is in “normal” flow and the valve will fail in the open position. When flow is “over-the seat-and down,” it is in “reverse” flow and the valve will fail in the closed position. There are no permanent flow arrow markings.



Recommended Tools

1. Three pressure gauges with ranges suitable to the installation to be put at Hytrol inlet, outlet and cover connections.
2. Cla-Val Model X101 Valve Position Indicator. This provides visual indication of valve position without disassembly of valve.
3. Other items are: suitable hand tools such as screwdrivers, wrenches, etc. soft jawed (brass or aluminum) vise, 400 grit wet or dry sandpaper and water for cleaning.

Troubleshooting

The following troubleshooting information deals strictly with the Model 100-01 Hytrol Valve. This assumes that all other components of the pilot control system have been checked out and are in proper working condition. (See appropriate sections in Technical Manual for complete valve).

All trouble shooting is possible without removing the valve from the line or removing the cover. It is highly recommended to permanently install a Model X101 Valve Position Indicator and three gauges in unused Hytrol inlet, outlet and cover connections.

SYMPTOM	PROBABLE CAUSE	REMEDY
Fails to Close	Closed isolation valves in control system, or in main line.	Open Isolation valves.
	Lack of cover chamber pressure.	Check upstream pressure, pilot system, strainer, tubing, valves, or needle valves for obstruction.
	Diaphragm damaged. (See Diaphragm Check.)	Replace diaphragm.
	Diaphragm assembly inoperative. Corrosion or excessive scale build up on valve stem. (See Freedom of Movement Check)	Clean and polish stem. Inspect and replace any damaged or badly eroded part.
	Mechanical obstruction. Object lodged in valve. (See Freedom of Movement Check)	Remove obstruction.
	Worn disc. (See Tight Sealing Check)	Replace disc.
	Badly scored seat. (See Tight Sealing Check)	Replace seat.
Fails to Open	Closed upstream and/or downstream isolation valves in main line.	Open isolation valves.
	Insufficient line pressure.	Check upstream pressure. (Minimum 5 psi flowing line pressure differential.)
	Diaphragm assembly inoperative. Corrosion or excessive buildup on valve stem. (See Freedom of Movement Check)	Clean and polish stem. Inspect and replace any damaged or badly eroded part.
	Diaphragm damaged. (For valves in "reverse flow" only)	Replace diaphragm.

After checking out probable causes and remedies, the following three checks can be used to diagnose the nature of the problem before maintenance is started. They must be done in the order shown.

Three Checks

The 100-01 Hytrol Valve has only one moving part (the diaphragm and disc assembly). So, there are only three major types of problems to be considered.

First: Valve is stuck - that is, the diaphragm assembly is not free to move through a full stroke either from open to close or vice versa.

Second: Valve is free to move and can't close because of a worn out diaphragm.

Third: Valve leaks even though it is free to move and the diaphragm isn't leaking.

CAUTION:

*Care should be taken when doing the troubleshooting checks on the 100-01 Hytrol Valve. These checks do require the valve to open fully. This will either allow a high flow rate through the valve, or the downstream pressure will quickly increase to the inlet pressure. In some cases, this can be very harmful. Where this is the case, and there are no block valves in the system to protect the downstream piping, it should be realized that **the valve cannot be serviced under pressure**. Steps should be taken to remedy this situation before proceeding any further.*

Diaphragm Check (#1)

1. Shut off pressure to the Hytrol Valve by slowly closing upstream and downstream isolation valves. **SEE CAUTION.**
2. Disconnect or close all pilot control lines to the valve cover and leave only one fitting in highest point of cover open to atmosphere.
3. With the cover vented to atmosphere, slowly open upstream isolation valve to allow some pressure into the Hytrol Valve body. Observe the open cover tapping for signs of continuous flow. It is not necessary to fully open isolating valve. Volume in cover chamber capacity chart will be displaced as valve moves to open position. Allow sufficient time for diaphragm assembly to shift positions. If there is no continuous flow, you can be quite certain the diaphragm is sound and the diaphragm assembly is tight. If the fluid appears to flow continuously this is a good reason to believe the diaphragm is either damaged or it is loose on the stem. In either case, this is sufficient cause to remove the valve cover and investigate the leakage. (See "Maintenance" Section for procedure.)

COVER CHAMBER CAPACITY (Liquid Volume displaced when valve opens)

Valve size (inches)	Displacement	
	Gallons	Liters
1 1/4	.020	.07
1 1/2	.020	.07
2	.032	.12
2 1/2	.043	.16
3	.080	.30
4	.169	.64
6	.531	2.0
8	1.26	4.8
10	2.51	9.5
12	4.00	15.1
14	6.50	24.6
16	9.57	36.2
20	12.00	45.4
24	29.00	109.8
30	42.00	197.0
36	90.00	340.0

Freedom of Movement Check (#2)

4. Determining the Hytrol Valve's freedom of movement can be done by one of two methods.
5. For most valves it can be done after completing Diaphragm Check (Steps 1, 2, and 3). **SEE CAUTION.** At the end of step 3 the valve should be fully open.
6. If the valve has a Cla-Val X101 Position Indicator, observe the indicator to see that the valve opens wide. Mark the point of maximum opening.
7. Re-connect enough of the control system to permit the application of inlet pressure to the cover. Open pilot system cock so pressure flows from the inlet into the cover.
8. While pressure is building up in the cover, the valve should close smoothly. There is a hesitation in every Hytrol Valve closure, which can be mistaken for a mechanical bind. The stem will appear to stop moving very briefly before going to the closed position. This slight pause is caused by the diaphragm flexing at a particular point in the valve's travel and is not caused by a mechanical bind.
9. When closed, a mark should be made on the X101 Valve position indicator corresponding to the "closed" position. The distance between the two marks should be approximately the stem travel shown in chart.

STEM TRAVEL

(Fully Open to Fully Closed)

Valve Size (inches)		Travel (inches)	
Inches	MM	Inches	MM
1 1/4	32	0.4	10
1 1/2	40	0.4	10
2	50	0.6	15
2 1/2	65	0.7	18
3	80	0.8	20
4	100	1.1	28
6	150	1.7	43
8	200	2.3	58
10	250	2.8	71
12	300	3.4	86
14	350	4.0	100
16	400	4.5	114
20	500	5.6	143
24	600	6.7	165
30	800	7.5	190
36	900	8.5	216

10. If the stroke is different than that shown in stem travel chart this is a good reason to believe something is mechanically restricting the stroke of the valve at one end of its travel. If the flow does not stop through the valve when in the indicated "closed" position, the obstruction probably is between the disc and the seat. If the flow does stop, then the obstruction is more likely in the cover. In either case, the cover must be removed, and the obstruction located and removed. The stem should also be checked for scale build-up. (See "Maintenance, section for procedure.)

11. For valves 6" and smaller, the Hytrol Valve's freedom of movement check can also be done after all pressure is removed from the valve. **SEE CAUTION.** After closing inlet and outlet isolation valves and bleeding pressure from the valve, check that the cover chamber and the body are temporarily vented to atmosphere. Insert fabricated tool into threaded hole in top of valve stem, and lift the diaphragm assembly manually. Note any roughness. The diaphragm assembly should move smoothly throughout entire valve stroke. The tool is fabricated from rod that is threaded on one end to fit valve stem and has a "T" bar handle of some kind on the other end for easy gripping. (See chart in Step 4 of "Disassembly" Section.)

12. Place marks on this diaphragm assembly lifting tool when the valve is closed and when manually positioned open. The distance between the two marks should be approximately the stem travel shown in stem travel chart. If the stroke is different than that shown, there is a good reason to believe something is mechanically restricting the stroke of the valve. The cover must be removed, and the obstruction located and removed. The stem should also be checked for scale build-up. (See "Maintenance" Section for procedure.)

Tight Sealing Check (#3)

13. Test for seat leakage after completing checks #1 & #2 (Steps 1 to 12). **SEE CAUTION.** Close the isolation valve downstream of the Hytrol Valve. Apply inlet pressure to the cover of the valve, wait until it closes. Install a pressure gauge between the two closed valves using one of the two ports in the outlet side of the Hytrol. Watch the pressure gauge. If the pressure begins to climb, then either the downstream isolation valve is permitting pressure to creep back, or the Hytrol is allowing pressure to go through it. Usually the pressure at the Hytrol inlet will be higher than on the isolation valve discharge, so if the pressure goes up to the inlet pressure, you can be sure the Hytrol is leaking. Install another gauge downstream of isolating valve. If the pressure between the valves only goes up to the pressure on the isolation valve discharge, the Hytrol Valve is holding tight, and it was just the isolation valve leaking.

Maintenance

Preventative Maintenance

The Cla-Val Co. Model 100-01 Hytrol Valve requires no lubrication or packing and a minimum of maintenance. However, a periodic inspection schedule should be established to determine how the operating conditions of the system are affecting the valve. The effect of these actions must be determined by inspection.

Disassembly

Inspection or maintenance can be accomplished without removing the valve from the line. Repair kits with new diaphragm and disc are recommended to be on hand before work begins.

WARNING: Maintenance personnel can be injured and equipment damaged if disassembly is attempted with pressure in the valve. **SEE CAUTION.**

1. Close upstream and downstream isolation valves **and independent operating pressure when used** to shut off all pressure to the valve.
2. Loosen tube fittings in the pilot system to remove pressure from valve body and cover chamber. After pressure has been released from the valve, use care to remove the controls and tubing. Note and sketch position of tubing and controls for re-assembly. The schematic in front of the Technical Manual can be used as a guide when reassembling pilot system.
3. Remove cover nuts and remove cover. If the valve has been in service for any length of time, chances are the cover will have to be loosened by driving upward along the edge of the cover with a **dull cold chisel**.

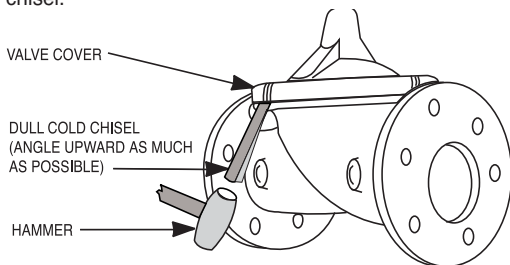

On 6" and smaller valves block and tackle or a power hoist can be used to lift valve cover by inserting proper size eye bolt in place of the center cover plug. on 8" and larger valves there are 4 holes (5/8" – 11 size) where jacking screws and/or eye bolts may be inserted for lifting purposes. **Pull cover straight up** to keep from damaging the integral seat bearing and stem.

COVER CENTER PLUG SIZE

Valve Size	Thread Size (NPT)
1 1/4" – 1 1/2"	1/4"
2" – 3"	1/2"
4" – 6"	3/4"
8" – 10"	1"
12"	1 1/4"
14"	1 1/2"
16"	2"
20" & 24"	2"
30" & 36"	2"

4. Remove the diaphragm and disc assembly from the valve body. With smaller valves this can be accomplished by hand by **pulling straight up on the stem so as not to damage the seat bearing**. On large valves, an eye bolt of proper size can be installed in the stem and the diaphragm assembly can be then lifted with a block and tackle or power hoist. Take care not to damage the stem or bearings. The valve won't work if these are damaged.

VALVE STEM THREAD SIZE

Valve Size	Thread Size (UNF Internal)
1 1/4" – 2 1/2"	10–32
3" – 4"	1/4–28
6" – 14"	3/8–24
16"	1/2–20
20	3/4–16
24"	3/4–16
30"	3/4–16
36"	3/4–16

5. The next item to remove is the stem nut. Examine the stem threads above the nut for signs of mineral deposits or corrosion. If the threads are not clean, use a wire brush to remove as much of the residue as possible. Attach a good fitting wrench to the nut and give it a sharp "rap" rather than a steady pull. Usually several blows are sufficient to loosen the nut for further removal. On the smaller valves, the entire diaphragm assembly can be held by the stem in a vise **equipped with soft brass jaws** before removing the stem nut.

The use of a pipe wrench or a vise without soft brass jaws scars the fine finish on the stem. No amount of careful dressing can restore the stem to its original condition. Damage to the finish of the stem can cause the stem to bind in the bearings and the valve will not open or close.

6. After the stem nut has been removed, the diaphragm assembly breaks down into its component parts. Removal of the disc from the disc retainer can be a problem if the valve has been in service for a long time. Using two screwdrivers inserted along the outside edge of the disc usually will accomplish its removal. Care should be taken to preserve the spacer washers in water, particularly if no new ones are available for re-assembly.

7. The only part left in the valve body is the seat which ordinarily does not require removal. Careful cleaning and polishing of inside and outside surfaces with 400 wet/dry sandpaper will usually restore the seat's sharp edge. If, however, it is badly worn and replacement is necessary, it can be easily removed.

Seats in valve sizes 1 1/4" through 6" are threaded into the valve body. They can be removed with accessory X109 Seat Removing Tool available from the factory. On 8" and larger valves, the seat is held in place by flat head machine screws. Use a tight-fitting, long shank screwdriver to prevent damage to seat screws. If upon removal of the screws the seat cannot be lifted out, it will be necessary to use a piece of angle or channel iron with a hole drilled in the center. Place it across the body so a long stud can be inserted through the center hole in the seat and the hole in the angle iron. By tightening the nut a uniform upward force is exerted on the seat for removal.

NOTE: Do not lift up on the end of the angle iron as this may force the integral bearing out of alignment, causing the stem to bind.

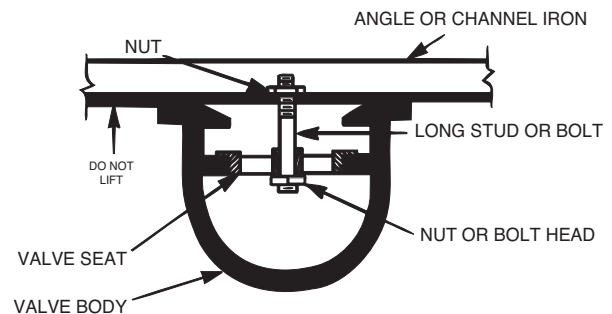

Lime Deposits

One of the easiest ways to remove lime deposits from the valve stem or other metal parts is to dip them in a 5-percent muriatic acid solution just long enough for the deposit to dissolve. This will remove most of the common types of deposits. **CAUTION: USE EXTREME CARE WHEN HANDLING ACID.** Rinse parts in water before handling. If the deposit is not removed by acid, then a fine grit (400) wet or dry sandpaper can be used with water.

Reassembly

1. Reassembly is the reverse of the disassembly procedure. If a new disc has been installed, it may require a different number of spacer washers to obtain the right amount of “grip” on the disc. When the diaphragm assembly has been tightened to a point where the diaphragm cannot be twisted, the disc should be compressed very slightly by the disc guide. Excessive compression should be avoided. Use just enough spacer washers to hold the disc firmly without noticeable compression.

2. MAKE SURE THE STEM NUT IS VERY TIGHT. Attach a good fitting wrench to the nut and give it a sharp “rap” rather than a steady pull. Usually several blows are sufficient to tighten the stem nut for final tightening. Failure to do so could allow the diaphragm to pull loose and tear when subjected to pressure.

Inspection of Parts

After the valve has been disassembled, each part should be examined carefully for signs of wear, corrosion, or any other abnormal condition. Usually, it is a good idea to replace the rubber parts (diaphragm and disc) unless they are free of signs of wear. These are available in a repair kit. Any other parts which appear doubtful should be replaced. **WHEN ORDERING PARTS, BE SURE TO GIVE COMPLETE NAMEPLATE DATA, ITEM NUMBER AND DESCRIPTION.**

NOTE: If a new disc isn't available, the existing disc can be turned over, exposing the unused surface for contact with the seat. The disc should be replaced as soon as practical.

3. Carefully install the diaphragm assembly by lowering the stem through the seat bearing. Take care not to damage the stem or bearing. Line up the diaphragm holes with the stud or bolt holes on the body. on larger valves with studs, it may be necessary to hold the diaphragm assembly up part way while putting the diaphragm over the studs.

4. Put spring in place and replace cover. Make sure diaphragm is lying smooth under the cover.

5. Tighten cover nuts firmly using a cross-over pattern until all nuts are tight.

6. Test Hytrol Valve before re-installing pilot valve system.

Test Procedure After Valve Assembly

There are a few simple tests which can be made in the field to make sure the Hytrol Valve has been assembled properly. Do these before installing pilot system and returning valve to service. These are similar to the three troubleshooting tests.

1. Check the diaphragm assembly for freedom of movement after all pressure is removed from the valve. **SEE CAUTION.** Insert fabricated tool into threaded hole in top of valve stem, and lift the diaphragm assembly manually. Note any roughness, sticking or grabbing. The diaphragm assembly should move smoothly throughout entire valve stroke. The tool is fabricated from rod that is threaded on one end to fit valve stem (See chart in Step 4 of “Disassembly” section.) and has a “T” Bar handle of some kind on the other end for easy gripping.

Place marks on this diaphragm assembly lifting tool when the valve is closed and when manually positioned open. The distance between the two marks should be approximately the stem travel shown in stem travel chart. (See “Freedom of Movement Check” section.) If the stroke is different than that shown, there is a good reason to believe something is mechanically restricting the stroke of the valve. The cover must be removed, the obstruction located and removed. (See “Maintenance” Section for procedure.)

Due to the weight of the diaphragm assembly this procedure is not possible on valves 8” and larger. on these valves, the same determination can be made by carefully introducing a low pressure-less than five psi) into the valve body with the cover vented. **SEE CAUTION.** Looking in cover center hole see the diaphragm assembly lift easily without hesitation, and then settle back easily when the pressure is removed.

2. To check the valve for drip-tight closure, a line should be connected from the inlet to the cover, and pressure applied at the inlet of the valve. If properly assembled, the valve should hold tight with as low as ten PSI at the inlet. See “Tight Sealing Check” section.)

3. With the line connected from the inlet to the cover, apply full working pressure to the inlet. Check all around the cover for any leaks. Re-tighten cover nuts if necessary to stop leaks past the diaphragm.

4. Remove pressure, then re-install the pilot system and tubing exactly as it was prior to removal. **Bleed air from all high points.**

5. Follow steps under “Start-Up and Adjustment” Section in Technical Manual for returning complete valve back to service.

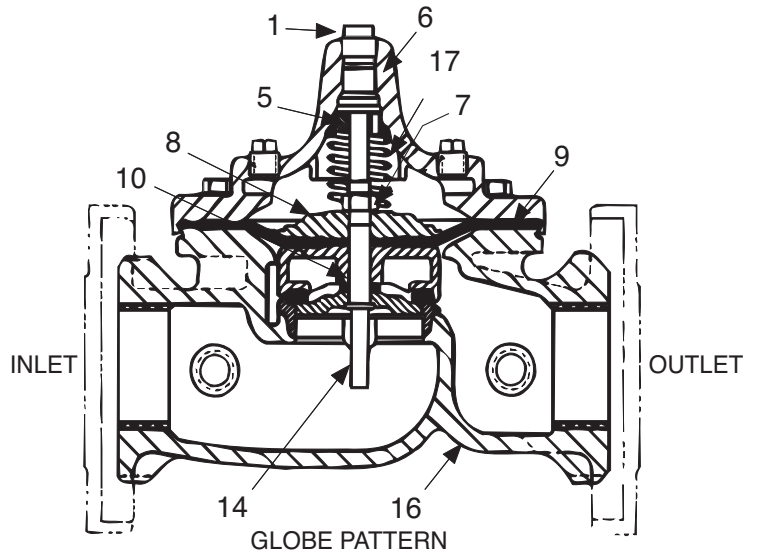
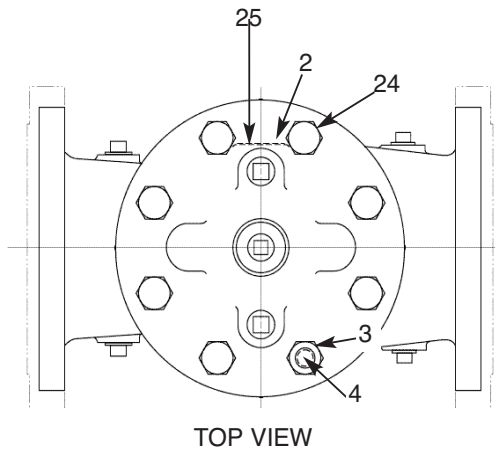

PARTS LIST

Item	Description
1.	Pipe Plug
2.	Drive Screws (for nameplate)
3.	Hex Nut (8" and larger)
4.	Stud (8" and larger)
5.	Cover Bearing
6.	Cover
7.	Stem Nut
8.	Diaphragm Washer
9.	Diaphragm
10.	Spacer Washers
11.	Disc Guide
12.	Disc Retainer
13.	Disc
14.	Stem
15.	Seat
16.	Body
17.	Spring
22.	Flat Head Screws (8" and larger)
23.	Seat O-Ring
24.	Hex head Bolt (1 1/4" thru 4")
25.	Nameplate
26.	Upper Spring Washer (Epoxy coated valves only)
27.	Lower Spring Washer (Epoxy coated valves only)
28.	Cover Bearing Housing (16" only)
29.	Cover O-Ring (16" only)
30.	Hex Bolt (16" only)
31.	Pipe Cap (16" only)

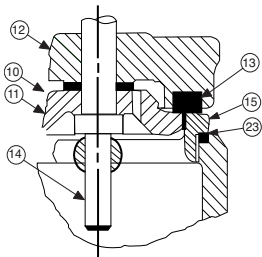
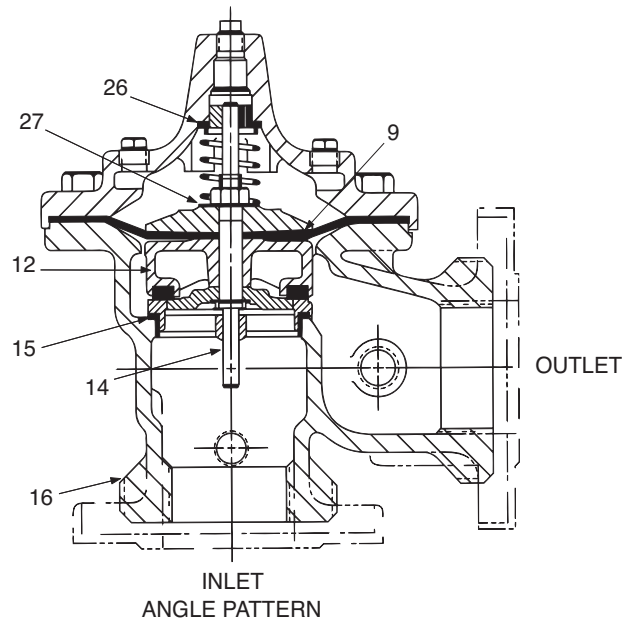

1 1/4" - 6" SEAT DETAIL

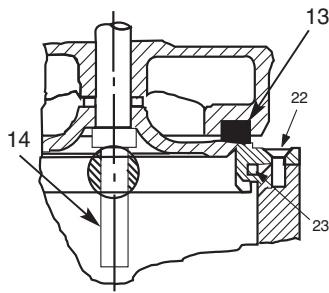

8" - 24" SEAT DETAIL

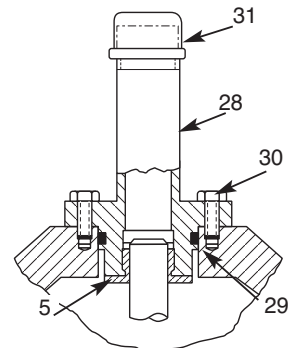

16" COVER DETAIL



—MODEL—100-01 Hytrol Valve Service Data

Description 100-01 Hytrol Valve

The Cla-Val Model 100-01 Hytrol Valve is a main valve for Cla-Val Automatic Control Valves. It is a hydraulically operated, diaphragm-actuated, globe or angle pattern valve.

This valve consists of three major components; body, diaphragm assembly, and cover. The diaphragm assembly is the only moving part. The diaphragm assembly uses a diaphragm of nylon fabric bonded with synthetic rubber. A synthetic rubber disc, contained on three and one half sides by a disc retainer and disc guide, forms a seal with the valve seat when pressure is applied above the diaphragm. The diaphragm assembly forms a sealed chamber in the upper portion of the valve, separating operating pressure from line pressure.

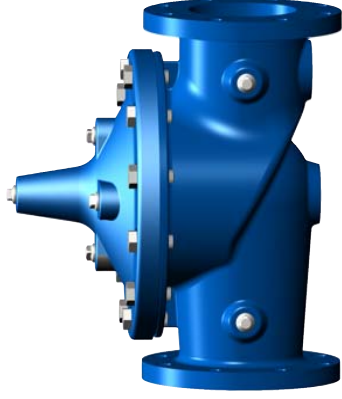

Description 100-20 600 Series Hytrol Valve

The Cla-Val Model 100-20 Hytrol Valve (600 Series main valve) have only one part -the body- that is different from standard 100 Series Cla-Val main valve parts. The remaining parts of the 600 series main valve are standard Cla-Val main valve parts. All service and maintenance information for the standard 100 Series main valves also apply to the 600 series main valves.

The most important thing to remember when ordering main valve repair kits and replacement parts, except for the body, all other parts are going to be for a smaller size main valve. Cla-Val identifies main valve parts with the flange size of the standard 100 Series main valve. Refer to the "Main Valve Sizes" chart below.

HYTROL Service Data

HYTROL SIZE		Stem Travel		Cover Capacity Displacement		Valve Stem Thread		Cover Center Plug		Cover Nut or Bolt			Cover Lifting Holes		Cover Plug		Cover Torque		Stem Nut**		Stem Nut Torque	
100-01	100-20	inches	mm	inches	mm	Gallons	Liters	UNF-Internal	NPT	Thread (Bolt)	Socket	Qty	UNC	Thread	Socket	ft. Lbs.	in. Lbs.	Thread	Socket (Long)	Lubed	DRY	
1"	25			0.3	8				1/4"	1/4" - 20 (B)	7/16"	8				4	48	3/8" - 24		4	6	
1 1/4"	32			0.4	10	0.020	0.07	10 - 32	1/4"	5/16" - 18 (B)	1/2"	8				8	96	7/16" - 20		6	10	
1 1/2"	40			0.4	10	0.020	0.07	10 - 32	1/4"	5/16" - 18 (B)	1/2"	8				8	96	7/16" - 20		6	10	
2"	50			0.6	15	0.032	0.12	10 - 32	1/2"	3/8" - 16 (B)	9/16"	8		3/8"	7/16"	12		1/2" - 20	3/4"	10	15	
2 1/2"	65			0.7	18	0.043	0.16	10 - 32	1/2"	7/16" - 14 (B)	5/8"	8		1/2"	9/16"	20		5/8" - 18	15/16"	21	30	
3"	80	4"	100	0.8	20	0.080	0.30	1/4 - 28	1/2"	1/2" - 13 (B)	3/4"	8		1/2"	9/16"	30		5/8" - 18	15/16"	21	30	
4"	100	6"	150	1.1	23	0.169	0.64	1/4 - 28	3/4"	3/4" - 10 (B)	1 1/8"	8		3/4"	5/8"	110		5/8" - 16	1 1/16"	40	60	
6"	150	8"	200	1.7	43	0.531	2.00	3/8 - 24	3/4"	3/4" - 10 (B)	1 1/8"	12		3/4"	5/8"	110		7/8" - 14	1 5/16"	85	125	
8"	200	10"	250	2.3	58	1.26	4.80	3/8 - 24	1"	3/4" - 10	1 1/4"	16	5/8" - 11	1"	13/16"	110		1 1/8" - 12	1 13/16"	125	185	
10"	250	12"	300	2.8	71	2.51	9.50	3/8 - 24	1"	7/8" - 9	1 7/16"	20	3/4" - 10	1"	13/16"	160		1 1/2" - 12	1 7/8"	252	375	
12"	300	16"	400	3.4	86	4.0	15.10	3/8 - 24	1 1/4"	1 1/8" - 7	1 13/16"	20	3/4" - 10	1"	13/16"	390		1 1/2" - 12	2 1/2"	270	400	
14"	350			3.9	99	6.5	24.60	3/8 - 24	1 1/2"	1 1/4" - 7	2"	20	1" - 8	1"	13/16"	545		1 1/2" - 12	2 1/2"	280	420	
16"	400	20", 24"	600	4.5	114	9.6	36.20	1/2 - 20	2"	1 1/4" - 7	2"	20	1" - 8	1"	13/16"	545		2" - 16	3"	500	750	
20"	500			5.63	143	12	45.40	3/4 - 16	1 1/2"	1 3/8" - 6	2 1/8"	24	1" - 8	1"	13/16"	670		2 1/4" - 16	3 1/2"	930	N/R	
24"	600	30"	800	6.75	165	29.0	108.80	3/4 - 16*	3/4"	1 1/2" - 12	2 3/8"	24	1 1/8" - 7	1"	13/16"	800		3" - 12	Special	1350	N/R	

* Adapter p/n 2594101E inside 1/4" - 28"

Grade 5 Bolts
"Heavy" Grade Nuts
Tighten cover nuts in a "star" cross-over pattern

** Must Use ONLY Cla-Val Supplied part

BOLT/NUT TORQUING PROCEDURES ON VALVE COVERS

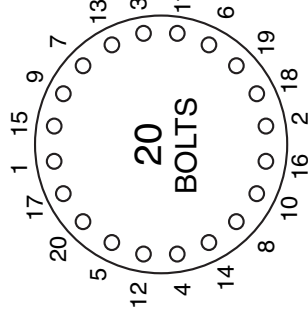
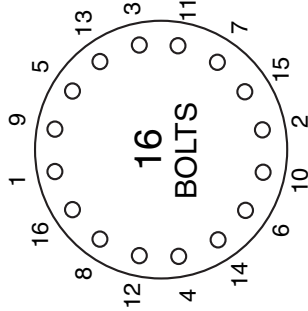
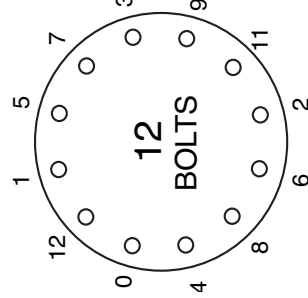
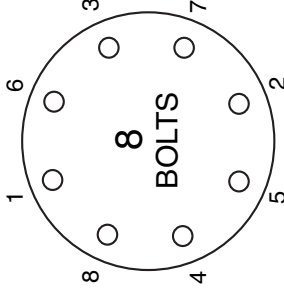
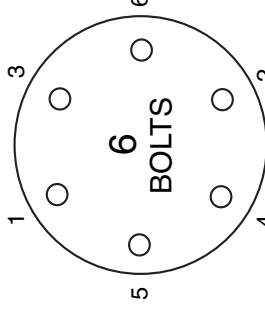
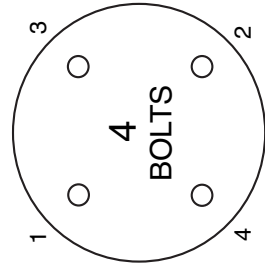

Follow this procedure when reassembling MAIN Valve:

1. Tightens bolts/nuts in a "Star" or "Cross-Over" pattern following the numbers shown above to insure that cover seats evenly on the diaphragm material and body.
2. Torque the bolt/nuts in three stages with a "Star" or "Cross-Over" pattern for each stage:
 - A. To approximately 10% of final torque.
 - B. To approximately 75% of final torque.
 - C. To final required torque.
3. Valves that are to be tested to 375 PSI or higher should be retorqued after 24 hours.

100-01 Hytrol Main Valve Assembly

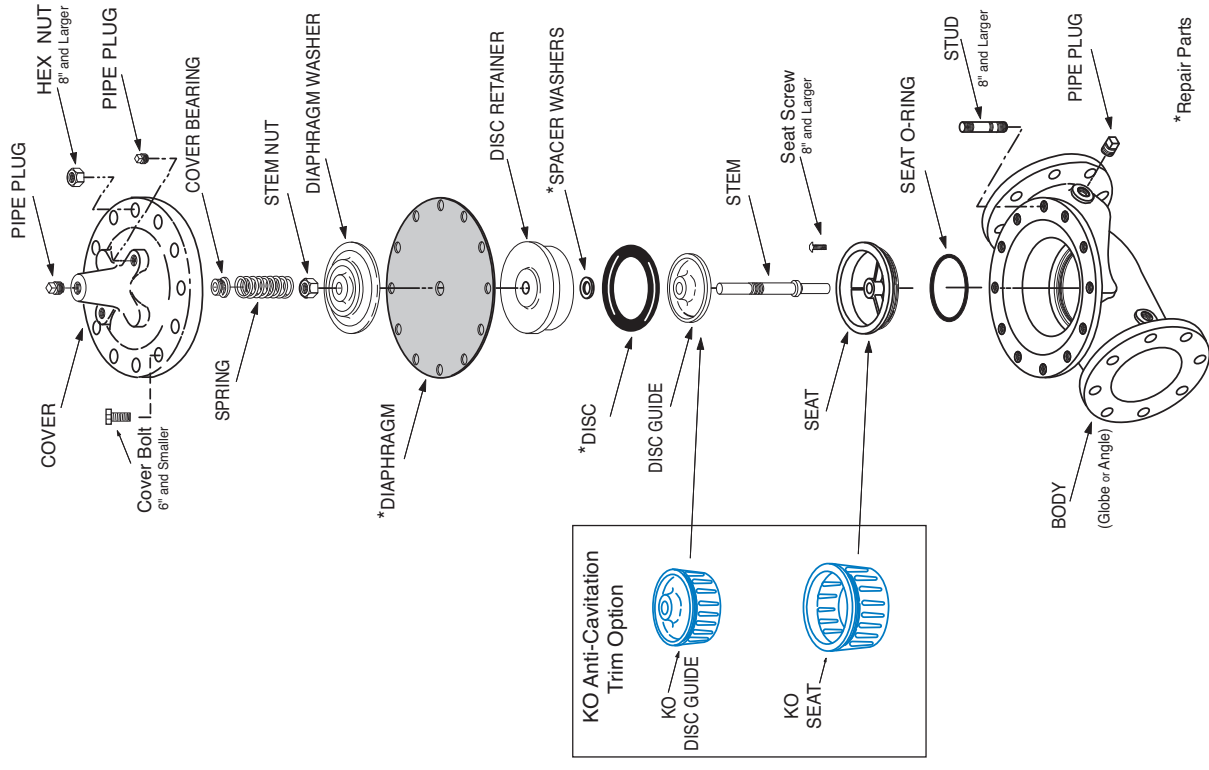



— MODEL — **100-20**
(Reduced Internal Port)

600 Series Hytrol Valve

SERVICE AND MAINTENANCE OF 600 SERIES VALVES

The 600 series main valves have only one part -the body- that is different from standard 100 Series Cla-Val main valve parts. The remaining parts of the 600 series main valve are standard Cla-Val main valve parts. All service and maintenance information for the standard 100 Series main valves in this manual also apply to the 600 series main valves.

The most important thing to remember when ordering main valve repair kits and replacement parts, except for the body, all other parts are going to be for a smaller size main valve. Cla-Val identifies main valve parts with the flange size of the standard 100 Series main valve. Refer to the "Main Valve Sizes Comparison" chart. For example, if you are servicing a 6" 100-20 Hytrol and needed a repair kit, you would order a repair kit for a 4" 100-01 Hytrol. This kit is also suitable for a 6" 100-20 Hytrol. Complete Technical Manuals include a repair kit data sheet N-RK that shows this relationship.

When you order repair parts, it is a good idea to include valve nameplate data (size, catalog number, and part number) and description of the parts desired. Do this to be sure parts will fit the valve you are working on and not be too big for it. Pilot controls and repair kits maintenance information remain the same for 100 or 600 Series valves.

UNDERSTANDING THE 600 SERIES VALVES

In 1987, Cla-Val introduced the Model 100-20 Hytrol as the basic main valve for the 600 Series of automatic control valves. To identify all new valves using the 100-20 Hytrol, an existing catalog number is modified. Making a 600 Series catalog number is simply done by using a "6" in front of the two digit catalog numbers or replacing the "2" with a "6" in three digit catalog numbers. Current schematics reflect both catalog numbers together separated by a slash (i.e. - 90-01/690-01, 58-02/658-02, 210-01/610-01, etc). Since these two valves 'share' the same catalog number and schematic, they provide the same function in a system. The only difference between the two valves is the relative capacity of the two main valve series.

The 100-01 Hytrol is the basic main valve for Cla-Val automatic control valves. This valve is the current version of the Clayton Hytrol valve design originated in 1936. The 100-01 Hytrol is designed as a full flow area valve. This means that the inlet, seat and outlet openings are the same size. Thus, the pressure drop is kept to a minimum for this globe style design.

The 100-20 Hytrol valve has all of the basic features and advantages of the original 100-01 Hytrol. Only one part has been changed - the body. It is designed with different size inlet, seat and outlet openings. The 100-20 Hytrol has inlet and outlet flanges one valve size larger than the seat opening size. This results in what is sometimes called a 'reduced port' main valve. For example, a 4" 100-20 valve has a 3" seat. Note: valve size is always determined by the flange size. The following chart compares the 100-01 and the 100-20 main valves.

Basic Main Valve Size Comparison		
Globe Pattern Valves		
Flange Size (inch)	Seat Size	
	100-01 (100 Series)	100-20 (600 Series)
3	3	2
4	4	3
6	6	4
8	8	6
10	10	8
12	12	10
14	14	----
16	16	12
18	----	16
20	20	16
24	24	16
30	30	24
36	36	30
42	----	36
48	----	36
Angle Pattern Valves		
Flange Size (inch)	Seat Size	
	100-01 (100 Series)	100-20 (600 Series)
4	4	3
6	6	4
8	8	6

The 100-20 Hytrol is available only in ductile iron, 150 and 300 pressure class, and Bronze trim standard. Available extra cost main valve options include stainless steel trim, epoxy coating, Dura-Kleen stem, Delrin sleeved stem, and high temperature rubber parts. All four basic main valves have a 600 Series version available with all of the same benefits and size relationships. The following chart shows the relationship of Cla-Val main valve catalog numbers.

Cla-Val Main Valves

Catalog Name	Catalog Number		
	Circa 1936	100-Series	600 Series
Hytrol	100 (Angle =2100)	100-01	100-20
Powertrol	100P & 100PA	100-02	100-21
Powercheck	100PC & 100PCA	100-03	100-22
Hycheck	181	100-04	100-23

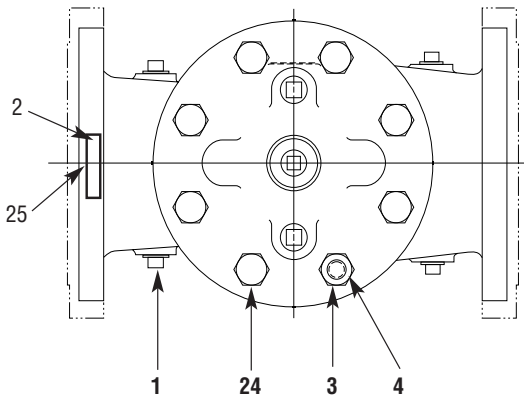

TOP VIEW

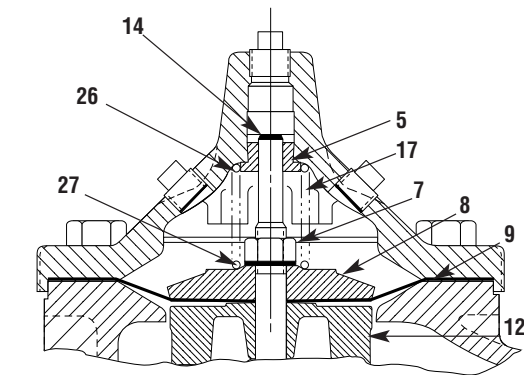
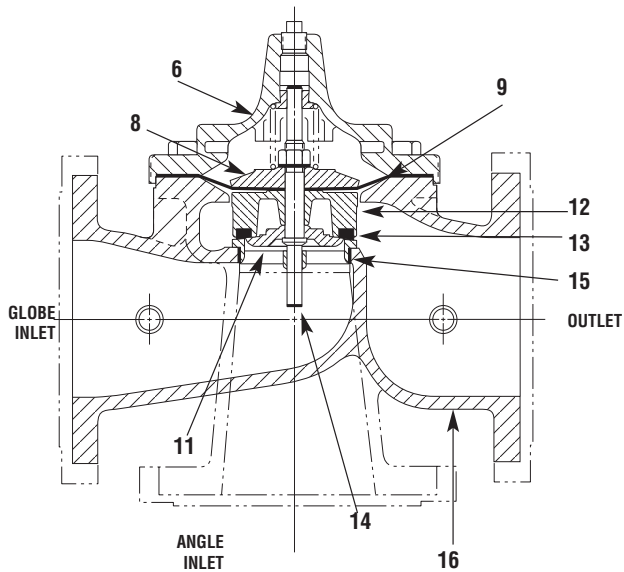

3" - 6" COVER DETAIL

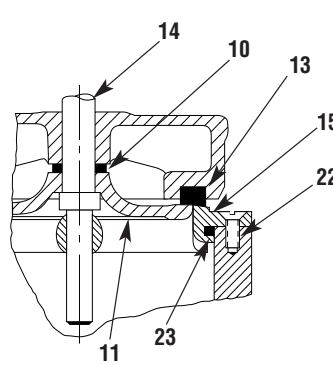

10" - 24" SEAT DETAIL

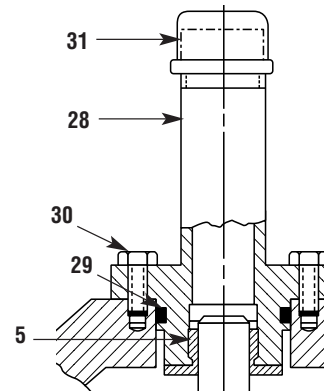

20" - 24" COVER DETAIL

PARTS LIST

NO. DESCRIPTION

- 1 Pipe Plug
- 2 Drive Screws (for nameplate)
- 3 Hex Nut (8" and larger)
- 4 Stud (8" and larger)
- 5 Cover Bearing
- 6 Cover
- 7 Stem Nut
- 8 Diaphragm Washer
- 9 Diaphragm
- 10 Spacer Washers
- 11 Disc Guide
- 12 Disc Retainer
- 13 Disc
- 14 Stem
- 15 Seat
- 16 Body
- 17 Spring
- 22 Flat Head Screws (10" and larger)
- 23 Seat O-Ring
- 24 Hex Bolt (3" Thru 6")
- 25 Nameplate (Mounted on inlet flange)
- 26 Upper Spring Washer (Epoxy coated valves only)
- 27 Lower Spring Washer (Epoxy coated valves only)
- 28 Cover Bearing Housing (20" & 24" & 30")
- 29 Cover Bearing Housing O-Ring (20" & 24" & 30")
- 30 Hex Bolt (20" & 24")
- 31 Pipe Cap (20" & 24" & 30")

WHEN ORDERING PARTS, BE SURE TO GIVE COMPLETE NAMEPLATE DATA, ITEM NUMBER AND DESCRIPTION.



— MODEL — **X47A**
Ejector



DESCRIPTION

The Cla-Val Model X47A Ejector is a compact, precision fitting, incorporating a primary and a secondary jet, designed to create a low-pressure area at the suction port.

OPERATION

The X47A Ejector is designed for use in a pilot control system on a Cla-Val Main Valve. Pressure is applied to the inlet port (A). As the fluid passes through the center portion of the X47A Ejector, the high velocity entrains particles of fluid from suction port (B), which results in a reduced pressure at this port.

In actual operation, the pressure port (A) is connected to the upstream side of the Main Valve; the discharge port (C) is connected to the Pilot Control; and the suction port (B) is connected to the cover chamber of the Main Valve.

Fluid line pressure enters at the inlet port (A). When the Pilot Control is closed, no flow occurs through the X47A Ejector, and full line pressure is directed into the Main Valve cover chamber, closing the Main Valve tight. As the Pilot Control opens, and flow through the X47A Ejector begins, pressure at the suction port (B) decreases until the Main Valve is permitted to open. Further changes in the flow rate resulting from opening and closing of the Pilot Control produce corresponding changes in the flow through the Main Valve.

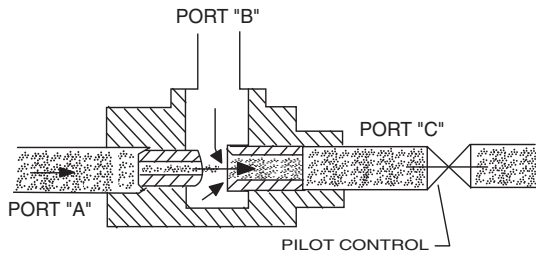

PILOT CONTROL OPEN

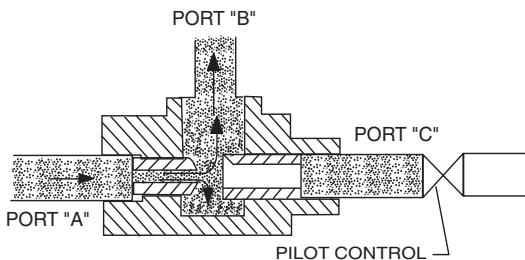

PILOT CONTROL CLOSED

DISASSEMBLY

Do not attempt to remove primary or secondary jets from X47A Ejector housing.

INSPECTION

Inspect port threads for damage or evidence of cross-threading. Check primary and secondary jets for clogging or embedded foreign particles. Check for breaks, cracks, fatigue, and other signs of damage.

CLEANING

After inspection, cleaning of the X47A can begin. Water service usually will produce mineral or lime deposits on metal parts in contact with water. These deposits can be cleaned by dipping the X47A in a 5-percent muriatic acid solution just long enough for deposits to dissolve. This will remove most of the common types of deposits. **Caution: use extreme care when handling acid.** If the deposit is not removed by acid, then a fine grit (400) or dry sandpaper can be used with water. Rinse parts in water before handling. An appropriate solvent can clean parts used in fueling service. Dry with compressed air or a clean, lint-free cloth. Protect from damage and dust until reassembled.

REPLACEMENT

If there is any sign of damage, or if there is the slightest doubt that the X47A Ejector may not afford completely satisfactory operation, replace it. Use Inspection steps as a guide. Neither the primary jet, secondary jet, or bare housing is furnished as a replacement part. Replace X47A Ejector as a complete unit.

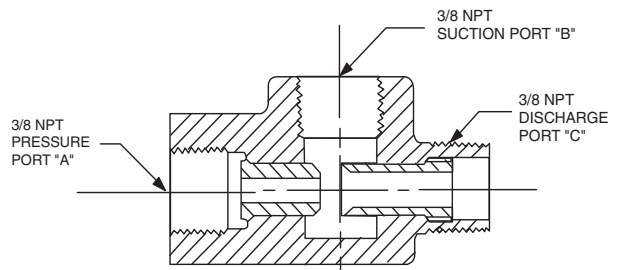

NOTE: OBTAIN AS COMPLETE ASSEMBLY ONLY. SPECIFY NUMBER STAMPED ON SIDE OF EJECTOR WHEN RE-ORDERING.



X47A

3/8" Ejector

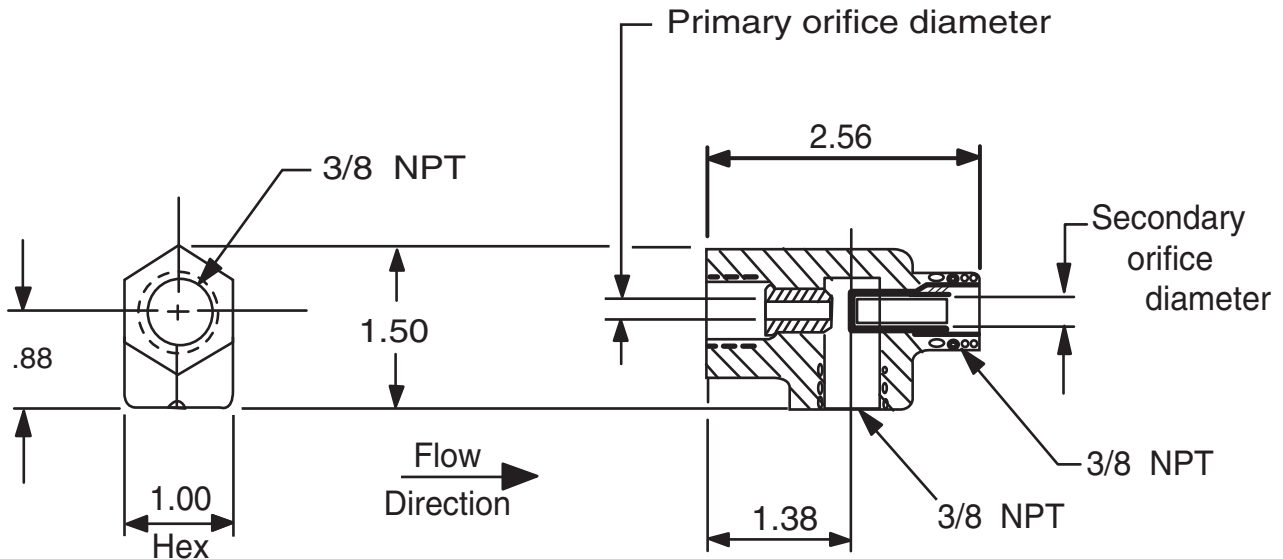

NOTE: Sold as complete assembly. No replacement parts available.

When ordering parts, please specify:

- Number Stamped on Side
- Description (X47A 3/8" Ejector)
- Orifice Dimensions
- Materials

BRONZE HOUSING - 303 S.S. INSERTS

CLA-VAL X47A STK. NO.	ORIFICE DIAMETER	
	PRIMARY	SECONDARY
C4311B	1/16	3/32
C4312K	1/8	3/16
C4089D	3/16	9/32

303 S.S. HOUSING - 303 S.S. INSERTS

CLA-VAL X47A STK. NO.	ORIFICE DIAMETER	
	PRIMARY	SECONDARY
32899H	1/16	3/32
C6168D	3/16	9/32
65274D	5/32	9/32



—MODEL— **CRD**

Pressure Reducing Control



DESCRIPTION

The Cla-Val Model CRD Pressure Reducing Control automatically reduces a higher inlet pressure to a lower outlet pressure. It is a direct acting, spring loaded, diaphragm type control that operates hydraulically or pneumatically. It may be used as a self-contained valve or as a pilot control for a Cla-Val main valve. It will hold a constant downstream pressure within very close pressure limits.

OPERATION

The CRD Pressure Reducing Control is normally held open by the force of the compression spring above the diaphragm; and delivery pressure acts on the underside of the diaphragm. Flow through the valve responds to changes in downstream demand to maintain a pressure.

INSTALLATION

The CRD Pressure Reducing Control may be installed in any position. There is one inlet port and two outlets, for either straight or angle installation. The second outlet port can be used for a gage connection. A flow arrow is marked on the body casting.

ADJUSTMENT PROCEDURE

The CRD Pressure Reducing Control can be adjusted to provide a delivery pressure range as specified on the nameplate. Pressure adjustment is made by turning the adjustment screw to vary the spring pressure on the diaphragm. The greater the compression on the spring the higher the pressure setting.

1. Turn the adjustment screw in (clockwise) to increase delivery pressure.
2. Turn the adjustment screw out (counter-clockwise) to decrease the delivery pressure.
3. When pressure adjustment is completed tighten jam nut on adjusting screw and replace protective cap.
4. When this control is used, as a pilot control on a Cla-Val main valve, the adjustment should be made under flowing conditions. The flow rate is not critical, but generally should be somewhat lower than normal in order to provide an inlet pressure several psi higher than the desired setting

The approximate minimum flow rates given in the table are for the main valve on which the CRD is installed.

Valve Size	1 1/4" -3"	4"-8"	10"-16"
Minimum Flow GPM	1-2	4-15	35-95

SYMPTOM	PROBABLE CAUSE	REMEDY
Fails to open when delivery pressure lowers	No spring compression	Tighten adjusting screw
	Damaged spring	Disassemble and replace
	Spring guide (8) is not in place	Assemble properly
	Yoke dragging on inlet nozzle	Disassemble and reassemble properly (refer to Reassembly)
Fails to close when delivery pressure rises	Spring compressed solid	Back off adjusting screw
	Mechanical obstruction	Disassemble and reassemble properly (refer to Reassembly)
	Worn disc	Disassemble remove and replace disc retainer assembly
	Yoke dragging on inlet nozzle	Disassemble and reassemble properly (refer to Reassembly)
Leakage from cover vent hole	Damaged diaphragm	Disassemble and replace
	Loose diaphragm nut	Remove cover and tighten nut

MAINTENANCE

Disassembly

To disassemble follow the sequence of the item numbers assigned to parts in the sectional illustration.

Reassembly

Reassembly is the reverse of disassembly. Caution must be taken to avoid having the yoke (17) drag on the inlet nozzle of the body (18). Follow this procedure:

1. Place yoke (17) in body and screw the disc retainer assembly (16) until it bottoms.
2. Install gasket (14) and spring (19) for 2-30 and 2-6.5 psi range onto plug (13) and fasten into body. Disc retainer must enter guide hole in plug as it is assembled. Screw the plug in by hand. Use wrench to tighten only.
3. Place diaphragm (12) diaphragm washer (11) and Belleville washer (20) on yoke. Screw on hex nut (10).
4. Hold the diaphragm so that the screw holes in the diaphragm and body align. Tighten diaphragm nut with a wrench. At the final tightening release the diaphragm and permit it to rotate 5° to 10°. The diaphragm holes should now be properly aligned with the body holes.

To check for proper alignment proceed as follows:

Rotate diaphragm clockwise and counterclockwise as far as possible. Diaphragm screw holes should rotate equal distance on either side of body screw holes ±1/8".

Repeat assembly procedure until diaphragm and yoke are properly aligned. There must be no contact between yoke and body nozzle during its normal movement. To simulate this movement hold body and diaphragm holes aligned. Move yoke to open and closed positions. There must be no evidence of contact or dragging.

5. Install spring (9) with spring guide (8).
6. Install cover (5), adjusting screw (2) and nut (3), then cap (1).



CRD

Pressure Reducing Control

(Bronze Body with 303SS Trim)

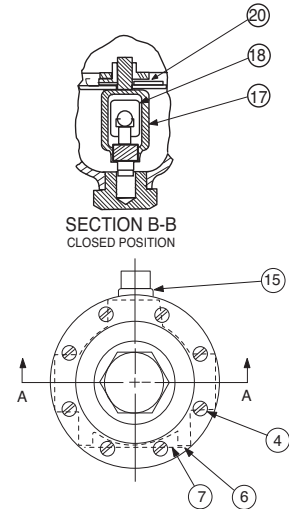
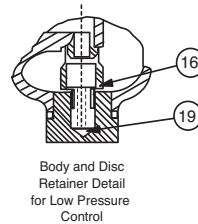
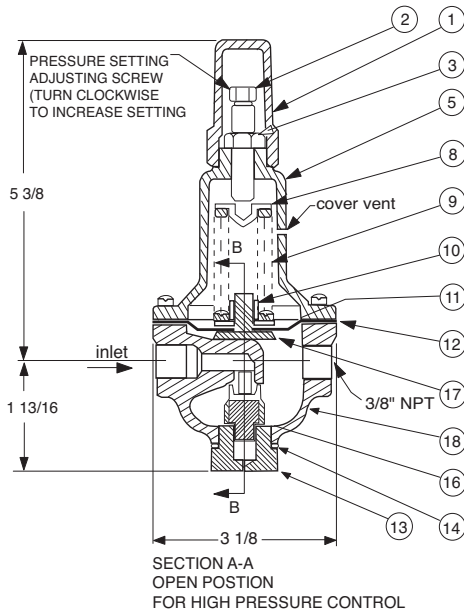

Size (inch)	Stock Number	Adjustment Range	
		psi	Ft of Water
3/8	7194307A	2 - 6.5	4.5 - 15
3/8	7194308J	2 - 30	4.5 - 69
3/8	7194303K	15 - 75	35 - 173
3/8	7194311C	20 - 105	46 - 242
3/8	7194304H	30 - 300	69 - 692
Factory Set Pressure		PSI per Turn*	
2 - 6.5 set @ 3.5 psi		.61	
2 - 30 set @ 10 psi		3.0	
15 - 75 set @ 20 psi		9.0	
20 - 105 set @ 60 psi		12.0	
30 - 300 set @ 60 psi		27.0	

*Approximate-Final Adjustment should be with a pressure gauge and with flow.

When ordering parts specify:

- All nameplate data
- Item Description
- Item number

Item	Description	Material	Part Number
1	Cap	PL	67628J
2	Adjusting Screw	BRS	7188201D
3	Jam Nut (3/8-16)	SS	6780106J
4*	Machine Screw (Fil.Hd.) 8 Req'd	303	6757821B
5	Cover	BRS	C2544K
6	Nameplate Screw	SS	67999D
7	Nameplate	BRS	C0022001G
8	Spring Guide	302	71881H
	Spring Guide (20 - 105 psi)	303	205620F
9	Spring (15-75 psi)	CHR/VAN	71884B
	Spring (2 - 6.5 psi)	SS	82575C
	Spring (2 - 30 psi)	SS	81594E
	Spring (20 - 105 psi)	316	20632101E
	Spring (30 - 300 psi)	CHR/VAN	71885J
10	Hex Nut	303	71883D
11	Diaphragm Washer	302	71891G
12*	Diaphragm	NBR	C6936D
13	Plug, Body	BRS	V5653A
14*	Gasket	Fiber	40174F
15	Plug	BRS	6766003F
16*	Disc Retainer Assy. (2 - 30 psi)	SS/Rub	C8348K
	Disc Retainer Assy. (15 - 75 psi)	SS/Rub	37133G
	Disc Retainer Assy. (20 - 105 psi)	SS/Rub	37133G
	Disc Retainer Assy. (30 - 300 psi)	SS/Rub	37133G
17	Yoke	VBZ	V6951H
18	Body & 1/4" Seat Assy	BR/SS	8339702G
19*	Bucking Spring (2 - 6.5 psi)(2 - 30psi)	302	V0558G
20	Belleville Washer	STL	7055007E
*	Repair Kit (No Bucking Spring)	Buna®-N	9170003K
*	Repair Kit (with Bucking Spring)	Buna®-N	9170002B

*SUGGESTED REPAIR PARTS



—MODEL— **CRD-L**

Pressure Reducing Control



Description

The Cla-Val Model CRDL Pressure Reducing Valve is designed for installation on potable water lines to automatically reduce high inlet pressure to a steady lower outlet pressure. This valve is an accurate regulator capable of holding downstream pressure to a predetermined amount regardless of upstream pressure fluctuations.

Operation

The Cla-Val Model CRDL Pressure Reducing Valve is a direct-acting, spring loaded, diaphragm type control, single seat design. The upstream pressure acts equally on the disc assembly, balancing the forces so that the opening and closing action is controlled by the downstream pressure acting on the underside of the diaphragm. The spring acts on the upper side of the diaphragm to provide an adjustable downstream pressure.

Installation

1. Before the CRDL is installed and commissioned, the water supply pipelines should be thoroughly flushed of all dirt, scale and foreign matter.
2. The CRDL can be installed in the vertical or horizontal position.
3. Place the valve in the pipeline with the flow through the valve in the direction of the arrow cast into the valve body.
4. Allow sufficient room around the valve to make adjustments and for maintenance.
5. It is recommended that isolating valves be installed at both ends of the CRDL for ease of isolating the valve during start-up, testing and maintenance.
6. Caution: Prior to pressurizing, a pressure gauge must be installed downstream of the CRDL to verify correct pressure setting.

Start-up and Adjustment

After initial installation or after any servicing of the CRDL, it is necessary to follow these steps.

1. Adjustment of the CRDL pressure reducing valve takes place exclusively under the responsibility of the person carrying it out.
2. With downstream isolating valve closed, slowly open upstream isolating valve.
3. With CRDL pressurized, slowly open downstream isolating valve, establishing a small amount of flow through the valve.
4. Remove plastic cap (16) and turn adjusting screw (15) to desired pressure setting. To increase pressure setting, turn clockwise. To decrease pressure setting, turn counter-clockwise.
5. Adjust pressure setting to desired downstream pressure. Adjust the screw slowly, in short increments. Check the result each time you make an adjustment.
6. Securely tighten locknut (14).

Note: It is always more accurate to fine tune and adjust the valve's pressure setting under actual flowing conditions. When in flowing condition, pressure will lower from static setting.

A minimum pressure differential of 15 PSI must be maintained.

When more than one valve is installed in series, check the pressure differential across each valve and adjust the valve downstream first.

When more than one valve is installed in parallel, adjust them to handle possible low flow conditions. This is done by setting one valve approximately 3 to 4 PSI greater than the setting on the other valves. It may be desirable to set all valves to same setting when flow rate fluctuations are not severe.

After completing pressure adjustment fully open the isolating valves.

Maintenance

Disassembly

Before starting any disassembly, close upstream and downstream isolation valves. Remove pressure from valve. Follow the sequence of the item numbers assigned to parts in the sectional illustration. To access, inspect, clean and/or replace internal parts:

1. Remove cap (16). Measure and mark distance of adjustment screw (15) as it is currently protruding from cover (12).
2. Loosen the lock-nut (14) and back off the adjusting screw (15) to release any spring tension.
3. Remove the eight cover screws (17). Remove cover (12), spring (11) and spring guide (13).
4. Unthread and remove the bottom plug (1) and O-ring (2) which exposes the disc retainer assembly. Unthread the disc retainer assembly (3) from the yoke (4); inspect, clean or replace disc retainer assembly (3) as required.
5. Unthread cap screw (10). Remove diaphragm washer (8) and Belleville washer (9) which exposes the diaphragm (18); inspect, clean or replace diaphragm (18) as required.
6. To replace seat (23), carefully detach the yoke (4) from the yoke holder (6) which allows access to the seat (23); inspect, clean or replace seat (23) and seat O-ring (22) as required.

Reassembly

Reassembly is the reverse of disassembly.

Caution must be taken to avoid having the yoke (4) drag on the inlet nozzle of the body (5). Follow this procedure to avoid yoke drag:

1. Place diaphragm (18), diaphragm washer (8) and Belleville washer (9) onto yoke (4). Screw on cap screw (10).
2. Hold diaphragm (18) so that the screw holes align with the body (5) screw holes.
3. Securely tighten cap screw (10) with wrench. At the final tightening release the diaphragm (18) and permit it to rotate 5° to 10°.
4. The diaphragm screw holes should now be properly aligned with the body screw holes.

To check for proper alignment proceed as follows:

After securely tightened, rotate diaphragm (18) clockwise and counterclockwise as far as possible. Diaphragm (18) screw holes should rotate equal distance on either side of body screw holes $\pm 1/8"$. Repeat assembly procedure until diaphragm (18) and yoke (4) are properly aligned. There must be no contact between yoke and body nozzle during its normal movement. To simulate this movement, align body and diaphragm holes, move yoke to open and closed positions. There must be no evidence of contact or dragging.

5. Reinstall disc retainer assembly (3).
6. Reinstall bottom plug (1), tighten securely.
7. Reinstall spring (11), spring guide (13), cover (12) and cover screws (17).
8. Securely tighten cover screws (17).
9. Reinstall adjusting screw (15) and lock nut (14).
10. Turn adjustment screw (15) into cover to the original measured setting.
11. Return valve to service.
12. Recheck or readjust pressure setting with flow through the valve.
13. To increase pressure setting, turn clockwise. To decrease pressure setting, turn counter-clockwise.
14. Once set point is established, securely tighten lock nut (14).
15. Reinstall and tighten cap (1).

Notice: To ensure proper performance and maximum service life for the CRDL, it is suggested that a program of regular inspection, testing, maintenance and cleaning be utilized. Annual inspection and maintenance is recommended.

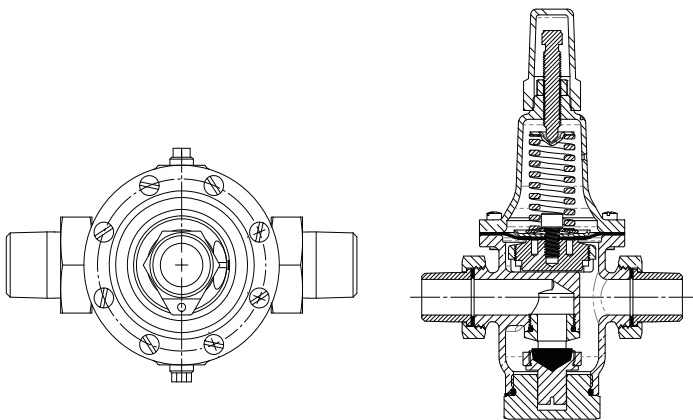

Tools Required:

For Pressure Adjustment: Fixed or adjustable wrench

For Maintenance:

1/4" Allen hex wrench, Slotted Screwdriver

When Ordering Parts

Please Specify:

1. All nameplate data
2. CRDL Size
3. Catalog Number and Item Number

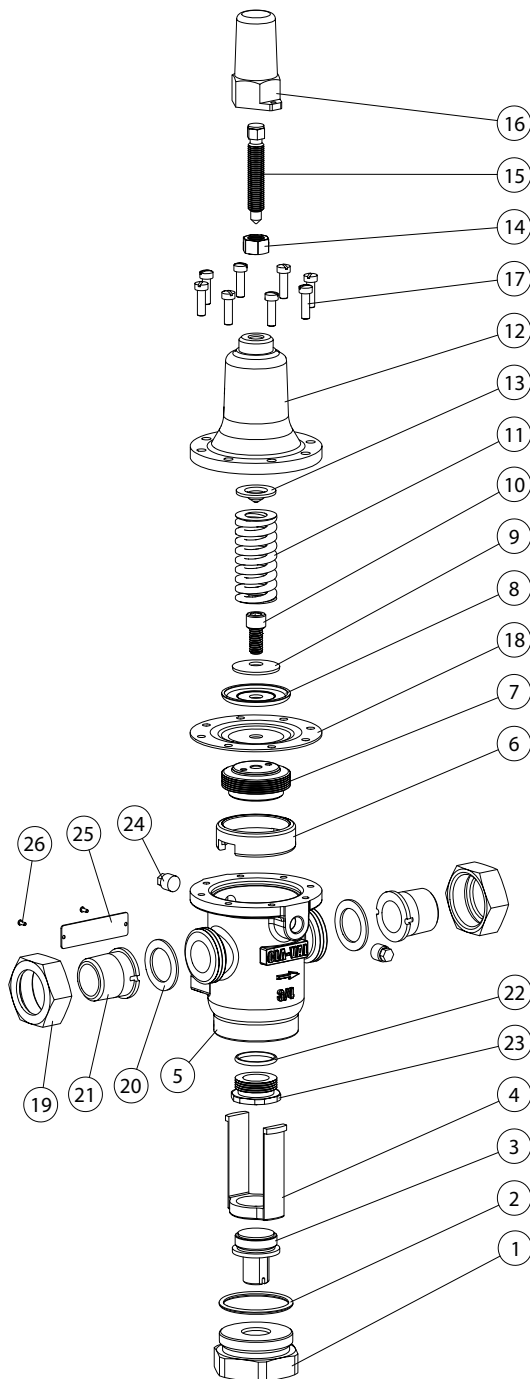

*** SUGGESTED REPAIR PARTS**

ID #	Description	Qty.
01	Plug	1
02 *	O-Ring	1
03 *	Disc Retainer Assembly	1
04	Yoke	1
05	Body	1
06	Yoke Holder Assembly	1
07	Yoke Retainer Assembly	1
08	Washer, Diaphragm, Upper	1
09	Washer, Belleville	1
10	Screw, Socket Head Cap	1
11	Spring	1
12	Cover	1
13	Guide, Spring	1
14	Nut, Lock	1
15	Screw, Adjusting	1
16	Cap	1
17 *	Screw	8
18 *	Diaphragm	1
19	Nut, Union	2
20 *	Gasket	2
21	Tail Piece, Union	2
22 *	O-Ring	1
23	Seat	1
24	Plug, Pipe	2
25	Nameplate	1
26	Drive Screw, Nameplate	2

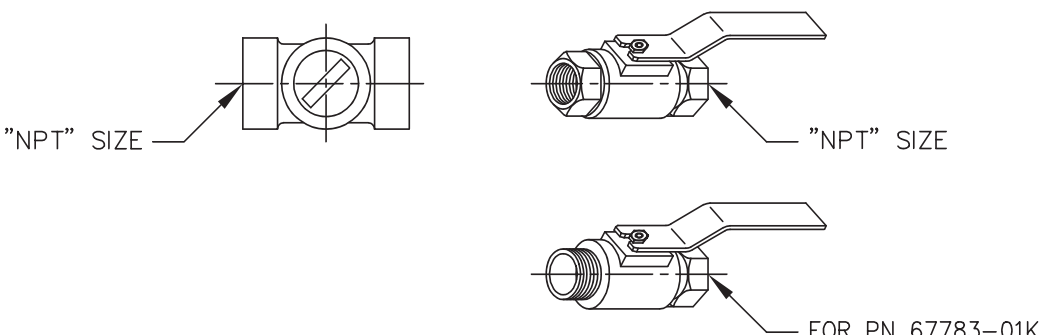
AK	07-10-08	AK	08-14-08	PC	10-1-2008			
	 CLA-VAL CO. NEWPORT BEACH, CALIFORNIA		CATALOG NO.		DRAWING NO. 67783	REV BD		
	TYPE OF VALVE AND MAIN FEATURES CK2 COCK/BALL VALVE					DESIGN DRAWN MGR 4-02-80 CHK'D KD 4-03-80 APV'D CH 4-07-80		
SCALE: NONE								
								
CLA-VAL PART NO. AND MATERIAL								
BRONZE WITH HANDLE	STEEL WITH HANDLE	IRON WITH HANDLE	316 SST WITH HANDLE	316 SST W/ LOCKING HANDLE	BRONZE WITH HANDLE	MONEL WITH HANDLE	MONEL W/ LOCKING HANDLE	SIZE "NPT"
67783-01K*	-09C	-17F	-25J SUPSD BY-26G		-41F SUPSD BY-01K			1/8"
-02H	-10A	-18D	-26G	-51E SUPSD BY-26G -52C	-42D SUPSD BY-02H	-55F		1/4"
-03F * -59H***	-11J	-19B	-27E	-46E SUPSD BY-27E -53A	-45G -57B**	-48A SUPSD BY-49J	-63K	3/8"
-04D -60F***	-12G	-20K	-28C	-54J	-43B SUPSD BY-04D	-49J	-62B	1/2"
-05A -61D***	-13E	-21H	-29A	-64H	-44K SUPSD BY-05A	-56D		3/4"
-06J	-14C	-22F	-30J			-58K		1"
-07G	-15K	-23D	-31G					1 1/4"
-08E	-16H	-24B	-32E					1 1/2"
-50G			-47C					2"
* SEE ENGINEERING APPROVED VENDORS TABLE (SHEET 2 OF 2). ** HAMMOND VALVE 8501 ONLY. *** WILKINS CK2 (SEE SHEET 2 OF 2)								

"THIS DRAWING IS THE PROPERTY OF CLA-VAL CO. AND SAME AND COPIES MADE THEREOF, IF ANY, SHALL BE RETURNED TO IT UPON DEMAND. DELIVERY AND DISCLOSURE HEREOF ARE SOLELY UPON CONDITION THAT THE SAME SHALL NOT BE USED, COPIED OR REPRODUCED, NOR SHALL THE SUBJECT HEREOF BE DISCLOSED IN ANY MANNER TO ANYONE FOR ANY PURPOSE, EXCEPT AS HEREIN AUTHORIZED, WITHOUT PRIOR WRITTEN APPROVAL OF CLA-VAL CO. THIS DRAWING IS SUBMITTED CONFIDENTIALLY AND MAY NOT BE USED IN THE MANUFACTURE OF ANY MATERIAL OR PRODUCT OTHER THAN SUCH MATERIALS AND PRODUCTS FURNISHED TO CLA-VAL CO. WHETHER OR NOT THE EQUIPMENT OR INFORMATION SHOWN HEREON IS PATENTED OR OTHERWISE PROTECTED, FULL TITLE AND COPYRIGHTS, IF ANY, IN AND TO THIS DRAWING AND/OR INFORMATION DELIVERED OR SUBMITTED ARE FULLY RESERVED CLA-VAL CO."



— MODEL — **X46**

Flow Clean Strainer



X46A Straight

- Self Scrubbing Cleaning Action
- Straight Type or Angle Type

The Cla-Val Model X46 Strainer is designed to prevent passage of foreign particles larger than .015". It is especially effective against such contaminant as algae, mud, scale, wood pulp, moss, and root fibers. There is a model for every Cla-Val. valve.

X46B Angle

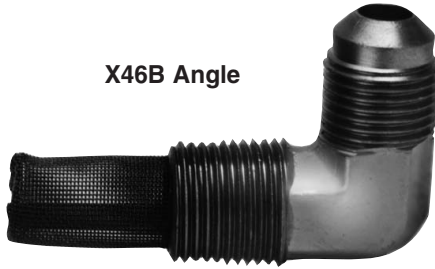

The X46 Flow Clean strainer operates on a velocity principle utilizing the circular "air foil" section to make it self cleaning. Impingement of particles is on the "leading edge" only. The low pressure area on the downstream side of the screen prevents foreign particles from clogging the screen. There is also a scouring action, due to eddy currents, which keeps most of the screen area clean.

Dimensions (In Inches)

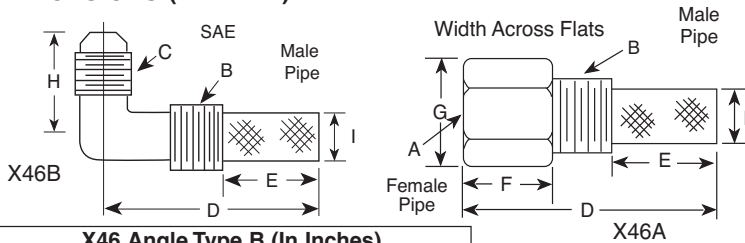

B(NPT)	C(SAE)	D	E	H	I
1/8	1/4	1-3/8	5/8	7/8	1/4
1/4	1/4	1-3/4	3/4	1	3/8
3/8	1/4	2	7/8	1	1/2
3/8	3/8	1-7/8	7/8	1	1/2
1/2	3/8	2-3/8	1	1-1/4	5/8

A (NPT)	B (NPT)	D	E	F	G	I
1/8	1/8	1-3/4	3/4	1/2	1/2	1/4
1/4	1/4	2-1/4	1	3/4	3/4	3/8
3/8	3/8	2-1/2	1	7/8	7/8	1/2
3/8	1/2	2-1/2	1-1/4	1/2	7/8	3/4
1/2	1/2	3	1-1/4	1	1-1/8	3/4
3/8	3/4	3-3/8	2	1/2	1	7/8
3/4	3/4	4	2	1	1-1/2	7/8
3/8	1	4-1/4	2-3/4	1/2	1-3/8	7/8
1	1	4-1/2	2-3/4	1-1/4	1-3/4	7/8
1/2	1	4-1/4	2-3/4	1/2	1-3/8	7/8

When Ordering, Please Specify:

- Catalog Number X46
- Straight Type or Angle Type
- Size Inserted Into and Size Connection
- Materials

INSTALLATION

The strainer is designed for use in conjunction with a Cla-Val Main Valve, but can be installed in any piping system where there is a moving fluid stream to keep it clean. When it is used with the Cla-Val Valve, it is threaded into the upstream body port provided for it on the side of the valve. It projects through the side of the Main Valve into the flow stream. All liquid shunted to the pilot control system and to the cover chamber of the Main Valve passes through the X46 Flow Clean Strainer.

INSPECTION

Inspect internal and external threads for damage or evidence of cross-threading. Check inner and outer screens for clogging, embedded foreign particles, breaks, cracks, corrosion, fatigue, and other signs of damage.

DISASSEMBLY

Do not attempt to remove the screens from the strainer housing.

CLEANING

After inspection, cleaning of the X46 can begin. Water service usually will produce mineral or lime deposits on metal parts in contact with water. These deposits can be cleaned by dipping X46 in a 5-percent muriatic acid solution just long enough for deposit to dissolve. This will remove most of the common types of deposits.

Caution: use extreme care when handling acid. If the deposit is not removed by acid, then a fine grit (400) wet or dry sandpaper can be used with water. Rinse parts in water before handling. An appropriate solvent can clean parts used in fueling service. Dry with compressed air or a clean, lint-free cloth. Protect from damage and dust until reassembled.

REPLACEMENT

If there is any sign of damage, or if there is the slightest doubt that the Model X46 Flow Clean Strainer may not afford completely satisfactory operation, replace it. Use Inspection steps as a guide. Neither inner screen, outer screen, nor housing is furnished as a replacement part. Replace Model X46 Flow Clean Strainer as a complete unit.

When ordering replacement Flow-Clean Strainers, it is important to determine pipe size of the tapped hole into which the strainer will be inserted (refer to column A or F), and the size of the external connection (refer to column B or G).



—MODEL— **CV**
Flow Control

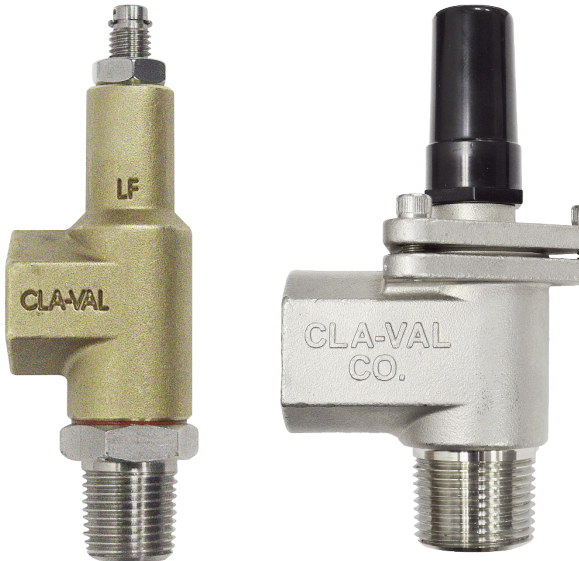

DESCRIPTION

The CV Control is an adjustable restriction which acts as a needle valve when flow is in the direction of the stem. When flow is in the reverse direction, the port area opens fully to allow unrestricted flow. When installed in the control system of a Cla-Val automatic valve, it can be arranged to function as either an opening or closing speed control.

OPERATION

The CV Flow Control permits full flow from port A to B, and restricted flow in the reverse direction. Flow from port A to B lifts the disc from seat, permitting full flow. Flow in the reverse direction seats the disc, causing fluid to pass through the clearance between the stem and the disc. This clearance can be increased, thereby increasing the restricted flow, by screwing the stem out, or counter-clockwise. Turning the stem in, or clockwise reduces the clearance between the stem and the disc, thereby reducing the restricted flow.'

INSTALLATION

Install the CV Flow Control as shown in the valve schematic. All connections must be tight to prevent leakage.

DISASSEMBLY

Follow the sequence of the item numbers assigned to the parts in the cross sectional illustration for recommended order of disassembly.

Use a scriber, or similar sharp-pointed tool to remove O-ring from the stem.

INSPECTION

Inspect all threads for damage or evidence of cross-threading. Check mating surface of seat and valve disc for excessive scoring or embedded foreign particles. Check spring for visible distortion, cracks and breaks. Inspect all parts for damage, corrosion and cleanliness.

CLEANING

After disassembly and inspection, cleaning of the parts can begin. Water service usually will produce mineral or lime deposits on metal parts in contact with water. These deposits can be cleaned by dipping the parts in a 5-percent muriatic acid solution just long enough for deposits to dissolve. This will remove most of the common types of deposits. **Caution: use extreme care when handling acid.** If the deposit is not removed by acid, then a fine grit (400) wet or dry sandpaper can be used with water. Rinse parts in water before handling. An appropriate solvent can clean parts used in fueling service. Dry with compressed air or a clean, lint-free cloth. Protect from damage and dust until reassembled.

REPAIR AND REPLACEMENT

Minor nicks and scratches may be polished out using a fine grade of emery or crocus cloth; replace parts if scratches cannot be removed.

Replace O-ring packing and gasket each time CV Flow Control is overhauled.

Replace all parts which are defective. Replace any parts which create the slightest doubt that they will not afford completely satisfactory operation. Use Inspection steps as a guide.

REASSEMBLY

Reassembly is the reverse of disassembly; no special tools are required.

TEST PROCEDURE

No testing of the flow Control is required prior to reassembly to the pilot control system on Cla-Val Main Valve.



CV Flow Control

3/8" CV Flow Control

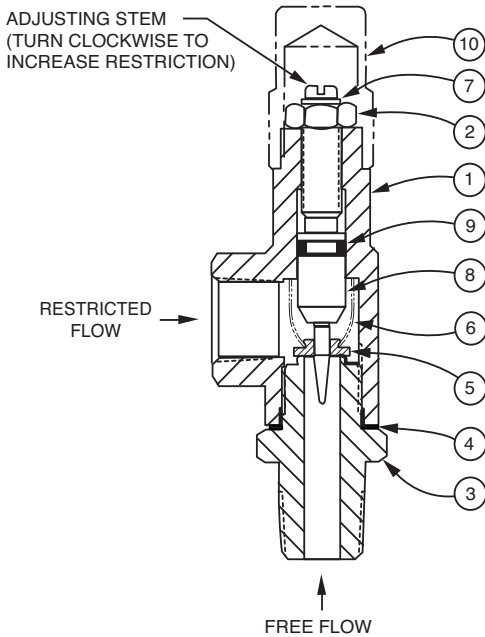

ITEM	DESCRIPTION	QTY
1	Housing	1
2	Nut, Jam	1
3	Seat	1
4	Gasket	1
5	Disc	1
6	Spring	1
7	Ring, Retaining	1
8	Stem	1
9	O-Ring	1
10	Cap (SS only)	1

1/2", 3/4", 1" CV Flow Control

When ordering parts, please specify:

- Number Stamped on Side
- Description (CV Flow Control)
- Part Description
- Material

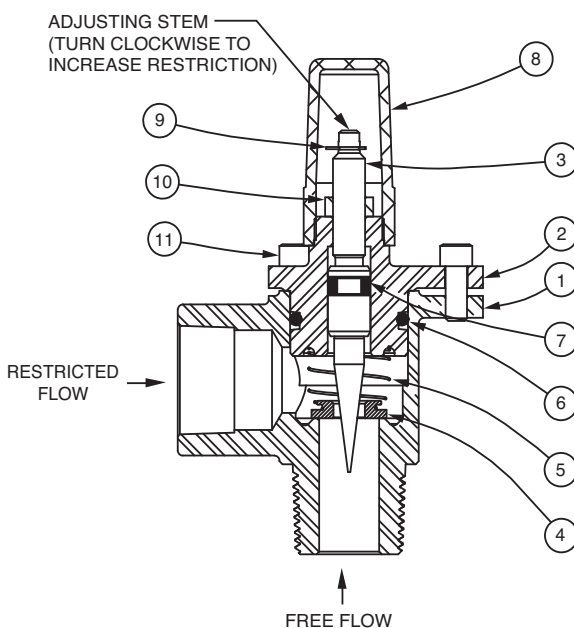

ITEM	DESCRIPTION	QTY
1	Body	1
2	Cover	1
3	Stem	1
4	Disc	1
5	Spring	1
6	O-Ring	1
7	O-Ring	1
8	Cap	1
9	Ring, Retaining	1
10	Nut, Jam	1
11	Socket Head Cap Screw	3



X43 Strainer

ITEM	DESCRIPTION	MATERIAL
1	Pipe Plug	Stainless Steel
2	Strainer Plug	Stainless Steel
3	Gasket	Fiber
4	Screen	Stainless Steel
5	Body	Stainless Steel

No parts available. Replacement assembly only.

Standard 60 mesh pilot system strainer for fluid service.

Size	Stock Number
3/8 x 3/8	8850604D

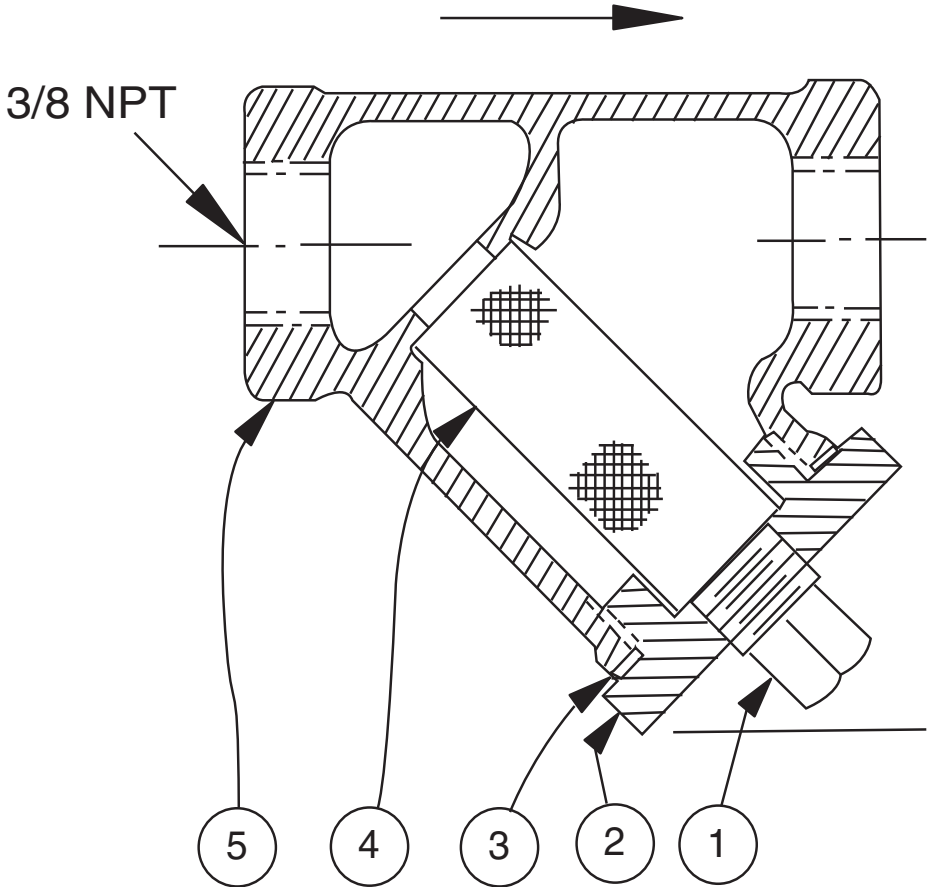

Proper Identification

For ordering repair kits, replacement parts, or for inquiries concerning valve operation, it is important to properly identify Cla-Val products already in service by including all nameplate data with your inquiry. Pertinent product data includes valve function, size, material, pressure rating, end details, type of pilot controls used and control adjustment ranges.

Identification Plates

For product identification, cast-in body markings are supplemented by identification plates as illustrated on this page. The plates, depending on type and size of product, are mounted in the most practical position. **It is extremely important that these identification plates are not painted over, removed, or in any other way rendered illegible.**

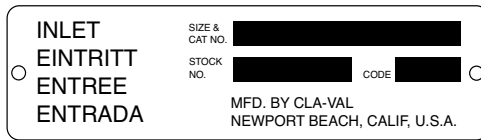

This brass plate appears on valves sized 2 1/2" and larger and is located on the top of the inlet flange.

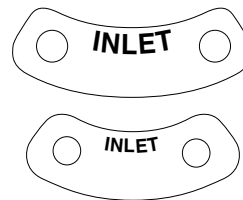

These two brass plates appear on 3/8", 1/2", and 3/4" size valves and are located on the valve cover.



This brass plate appears on altitude valves only and is found on top of the outlet flange.

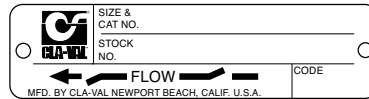

These two brass plates appear on threaded valves 1" through 3" size or flanged valves 1" through 2". It is located on only one side of the valve body.

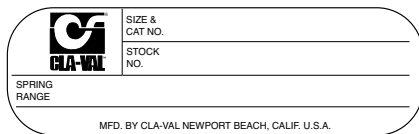

This tag is affixed to the cover of the pilot control valve. The adjustment range appears in the spring range section.

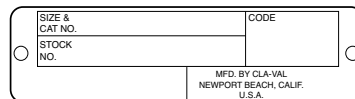

This brass plate is used to identify pilot control valves. The adjustment range is stamped into the plate.

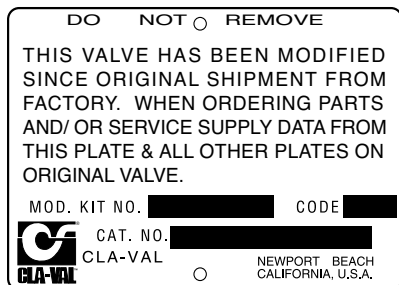

This aluminum plate is included in pilot system modification kits and is to be wired to the new pilot control system after installation.

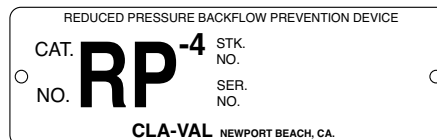

This brass plate is used on our backflow prevention assemblies. It is located on the side of the Number Two check (2" through 10"). The serial number of the assembly is also stamped on the top of the inlet flange of the Number One check.

HOW TO ORDER

Because of the vast number of possible configurations and combinations available, many valves and controls are not shown in published product and price lists. For ordering information, price and availability on product that are not listed, please contact your local Cla-Val office or our factory office located at:

P. O. Box 1325
Newport Beach, California 92659-0325
(949) 722-4800
FAX (949) 548-5441

SPECIFY WHEN ORDERING

- Model Number
- Globe or Angle Pattern
- Adjustment Range (As Applicable)
- Valve Size
- Threaded or Flanged
- Body and Trim Materials
- Optional Features
- Pressure Class

UNLESS OTHERWISE SPECIFIED

- Globe or angle pattern are the same price
- Ductile iron body and bronze trim are standard
- X46 Flow Clean Strainer or X43 "Y" Strainer are included
- CK2 Isolation Valves are included in price on 4" and larger valve sizes (6" and larger on 600 Series)

LIMITED WARRANTY

Automatic valves and controls as manufactured by Cla-Val are warranted for three years from date of shipment against manufacturing defects in material and workmanship that develop in the service for which they are designed, provided the products are installed and used in accordance with all applicable instructions and limitations issued by Cla-Val. Electronic components manufactured by Cla-Val are warranted for one year from the date of shipment.

We will repair or replace defective material, free of charge, that is returned to our factory, transportation charges prepaid, if upon inspection, the material is found to have been defective at time of original shipment. This warranty is expressly conditioned on the purchaser's providing written notification to Cla-Val immediate upon discovery of the defect.

Components used by Cla-Val but manufactured by others, are warranted only to the extent of that manufacturer's guarantee.

This warranty shall not apply if the product has been altered or repaired by others, Cla-Val shall make no allowance or credit for such repairs or alterations unless authorized in writing by Cla-Val.

DISCLAIMER OF WARRANTIES AND LIMITATIONS OF LIABILITY

The foregoing warranty is exclusive and in lieu of all other warranties and representations, whether expressed, implied, oral or written, including but not limited to any implied warranties or merchantability or fitness for a particular purpose. All such other warranties and representations are hereby cancelled.

Cla-Val shall not be liable for any incidental or consequential loss, damage or expense arising directly or indirectly from the use of the product. Cla-Val shall not be liable for any damages or charges for labor or expense in making repairs or adjustments to the product. Cla-Val shall not be liable for any damages or charges sustained in the adaptation or use of its engineering data and services. No representative of Cla-Val may change any of the foregoing or assume any additional liability or responsibility in connection with the product. The liability of Cla-Val is limited to material replacements F.O.B. Newport Beach, California.

TERMS OF SALE

ACCEPTANCE OF ORDERS

All orders are subject to acceptance by our main office at Newport Beach, California.

CREDIT TERMS

Credit terms are net thirty (30) days from date of invoice.

PURCHASE ORDER FORMS

Orders submitted on customer's own purchase order forms will be accepted only with the express understanding that no statements, clauses, or conditions contained in said order form will be binding on the Seller if they in any way modify the Seller's own terms and conditions of sales.

PRODUCT CHANGES

The right is reserved to make changes in pattern, design or materials when deemed necessary, without prior notice.

PRICES

All prices are F.O.B. Newport Beach, California unless expressly stated otherwise on our acknowledgement of the order. Prices are subject to change without notice. The prices at which any order is accepted are subject to adjustment to the Seller's price in effect at the time of shipment. Prices do not include sales, excise, municipal, state or any other Government taxes. Minimum order charge \$100.00.

RESPONSIBILITY

We will not be responsible for delays resulting from strikes, accidents, negligence of carriers, or other causes beyond our control. Also, we will not be liable for any unauthorized product alterations or charges accruing there from.

RISK

All goods are shipped at the risk of the purchaser after they have been delivered by to the carrier. Claims for error, shortages, etc., must be made upon receipt of goods.

EXPORT SHIPMENTS

Export shipments are subject to an additional charge for export packing.

RETURNED GOODS

1. Customers must obtain written approval from Cla-Val prior to returning any material.
2. Cla-Val reserves the right to refuse the return of any products.
3. Products more than six (6) months old cannot be returned for credit.
4. Specially produced, non-standard models cannot be returned for credit.
5. Rubber goods such as diaphragms, discs, o-rings, etc., cannot be returned for credit, unless as part of an unopened vacuum sealed repair kit which is less than six months old.
6. Goods authorized for return are subject to a 35% (\$100 minimum) restocking charge and a service charge for inspection, reconditioning, replacement of rubber parts, retesting, repainting and repackaging as required.
7. Authorized returned goods must be packaged and shipped prepaid to Cla-Val, 1701 Placentia Avenue, Costa Mesa, California 92627.



E-Product I.D. (R-3/2011)

CLA-VAL

PO Box 1325 Newport Beach CA 92659-0325
Phone: 949-722-4800 • Fax: 949-548-5441

CLA-VAL CANADA

4687 Christie Drive
Beamsville, Ontario
Canada L0R 1B4
Phone: 905-563-4963
Fax: 905-563-4040

CLA-VAL EUROPE

Chemin des Mesanges 1
CH-1032 Romanel/
Lausanne, Switzerland
Phone: 41-21-643-15-55
Fax: 41-21-643-15-50

©COPYRIGHT CLA-VAL 2011 Printed in USA
Specifications subject to change without notice.

www.cla-val.com

Represented By:



—MODEL— **REPAIR KITS**

Model 100-01 Hytrol Main Valve

BUNA-N MATERIAL				
	RUBBER KIT	REPAIR KIT	REBUILD ASSEMBLY	STUD & NUT KIT
	STOCK NO.	STOCK NO.	STOCK NO.	STOCK NO.
3/8"	9169801K		21176614B	21176633J
1/2"	9169802H	21176602F	21176615A	21176634H
3/4"	9169802H	21176602F	21176615A	21176634H
1" Non-Guided	9169803F	21176601G	21176616K	21176636F
1"	9169804D	21176603E	21176617J	21176636F
1 1/4"	9169804D	21176603E	21176617J	21176636F
1 1/2"	9169804D	21176603E	21176617J	21176636F
2"	9169805A	21176608K	21176618H	21176637E
2 1/2"	9169811J	21176609J	21176619G	21176638D
3"	9169812G	21176604D	21176620D	21176639C
4"	9169813E	21176605C	21176621C	21176640K
6"	9169815K	21176606B	21176622B	21176641J
8"	9817901D	21176607A	21176623A	21176642H
10"	9817902B	21176610F	21176624K	21176643G
12"	9817903K	21176611E	21176625J	21176644F
14"	9817904H	21176612D	21176626H	21176645E
16"	9817905E	21176613C	21176627G	21176645E

Model 100-20 Hytrol Main Valve

BUNA-N MATERIAL				
	RUBBER KIT	REPAIR KIT	REBUILD ASSEMBLY	STUD & NUT KIT
	STOCK NO.	STOCK NO.	STOCK NO.	STOCK NO.
3"	9169805A	21176608K	21176618H	21176637E
4"	9169812G	21176604D	21176620D	21176639C
6"	9169813E	21176605C	21176621C	21176640K
8"	9169815K	21176606B	21176622B	21176641J
10"	9817901D	21176607A	21176623A	21176642H
12"	9817902B	21176610F	21176624K	21176643G
14"	9817903K	21176611E	21176625J	21176644F
16"	9817903K	21176611E	21176625J	21176644F

Consult factory for larger sizes

Rubber Kit Includes: Diaphragm, Disc, Spacer Washers

Repair Kit Includes: Diaphragm, Disc, Spacer Washers, Epoxy Coated Disc Retainer, Epoxy Coated Diaphragm Washer, Protective Washer

Rebuild Assembly Includes: Diaphragm, Disc, Spacer Washers, Epoxy Coated Disc Retainer, Epoxy Coated Diaphragm Washer, Protective Washer, Stainless Steel Bolts & Washers (6" & Below), Stainless Steel Studs, Nuts, & Washers (8" & Above), Stem, Stem Nut, Disc Guide, Standard Cover Spring, Cover Washer

Stud & Nut Kit Includes: Stainless Steel Bolts & Washers (6" & Below), Stainless Steel Studs, Nuts, & Washers (8" & Above)

Repair Kits for 100-02/100-21 Powertrol and 100-03/100-22 Powercheck Main Valves

For: Powertrol and Powercheck Main Valves—150 Pressure Class Only

Includes: Diaphragm, Disc (or Disc Assembly) and O-rings and full set of spare Spacer Washers.

Valve Size	Kit Stock Number 100-02	Valve Size	Kit Stock Number	
			100-02 & 100-03	100-21 & 100-22
3/8"	9169901H	2 1/2"	9169910J	N/A
1/2" & 3/4"	9169902F	3"	9169911G	9169905J
1"	9169903D	4"	9169912E	9169911G
1 1/4" & 1 1/2"	9169904B	6"	9169913C	9169912E
2"	9169905J	8"	99116G	9169913C
		10"	9169939H	99116G
		12"	9169937B	9169939H

Larger Sizes: Consult Factory.

Repair Kits for 100-04/100-23 Hy-Check Main Valves

For: Hy-Check Main Valves—150 Pressure Class Only

Includes: Diaphragm, Disc and O-Rings and full set of spare Spacer Washers.

Valve Size	Kit Stock Number		Valve Size	Kit Stock Number	
	100-04	100-23		100-04	100-23
4"	20210901B	N/A	12"	20210905H	20210904J
6"	20210902A	20210901B	14"	20210906G	N/A
8"	20210903K	20210902A	16"	20210907F	20210905H
10"	20210904J	20210903K	20"	N/A	20210907F
			24"	N/A	20210907F

Larger Sizes: Consult Factory.

Repair Kits for Pilot Control Valves (In Standard Materials Only)

Includes: Diaphragm, Disc (or Disc Assembly), O-Rings, Gaskets or spare Screws as appropriate.

BUNA-N® (Standard Material)				VITON (For KB Controls)	
Pilot Control	Kit Stock Number	Pilot Control	Kit Stock Number	Pilot Control	Kit Stock Number
CDB	9170006C	CFM-9	12223E	CDB-KB	9170012A
CDB-30	9170023H	CRA (w/bucking spring)	9170001D	CRA-KB	N/A
CDB-31	9170024F	CRD (w/bucking spring)	9170002B	CRD-KB (w/bucking spring)	9170008J
CDB-7	9170017K	CRD (no bucking spring)	9170003K	CRL-KB	9170013J
CDH-2	18225D	CRD-18	20275401K	CDHS-2BKB	9170010E
CDHS-2	44607A	CRD-22	98923G	CDHS-2FKB	9170011C
CDHS-2B	9170004H	CRL (55F, 55L)	9170007A	CDHS-18KB (no bucking spring)	9170009G
CDHS-2F	9170005E	CRL60/55L-60	9170033G	102C-KB	1726202D
CDHS-3C-A2	24657K	CRL60/55L60 1"	9170042H		
CDHS-8A	2666901A	CRL-4A	43413E		
CDHS-18	9170003K	CRL-5 (55B)	65755B		
CDS-4	9170014G	CRL-5A (55G)	20666E		
CDS-5	14200A	CRL-18	20309801C		
CDS-6	20119301A	Universal CRL	9170041K		
CDS-6A	20349401C	CV	9170019F		
CFCM-M1	1222301C	X105L (O-ring)	00951E	Buna-N®	
CFM-2	12223E	102B-1	1502201F		
CFM-7	1263901K	102C-2	1726201F	CRD Disc Ret. (Solid)	C5256H
CFM-7A	1263901K	102C-3	1726201F	CRD Disc Ret. (Spring)	C5255K

Repair Assemblies (In Standard Materials Only)

Control	Description	Stock Number
CF1-C1	Pilot Assembly Only	89541H
CF1-CI	Complete Float Control less Ball and Rod	89016A
CFC2-C1	Disc, Distributor and Seals	2674701E
CSM 11-A2-2	Mechanical Parts Assembly	97544B
CSM 11-A2-2	Pilot Assembly Only	18053K
33A 1"	Complete Internal Assembly and Seal	2036030B
33A 2"	Complete Internal Assembly and Seal	2040830J

When ordering, please give complete nameplate data of the valve and/or control being repaired. MINIMUM ORDER CHARGE APPLIES

CLA-VAL

1701 Placentia Ave • Costa Mesa CA 92627 Phone: 949-722-4800 • Fax: 949-548-5441 • E-mail: info@cla-val.com • www.cla-val.com

© Copyright Cla-Val 2019 Printed in USA Specifications subject to change without notice.

N-RK (R-04/2019)