



# — MODEL — CRL-60

## Pressure Relief Control

- **Direct Acting - Precise Pressure Control**
- **Positive Dependable Opening**
- **Drip Tight Closure**
- **Remote Sensing**
- **Sensitive to Small Pressure Variations**



The Cla-Val Model CRL-60 Pressure Relief Valve is a direct-acting, spring loaded, diaphragm type relief valve. Often used as a pilot control for Cla-Val Hytrol valves, it can also be used as a standalone pressure relief valve. The CRL-60 may be installed in any position. It opens and closes within very close pressure limits. The bottom plug may be removed and installed in the inlet to convert it to an angle pattern flow path.

The Model CRL-60 is normally held closed by the force of the compression spring above the diaphragm. Control pressure is applied under the diaphragm. When the controlling pressure exceeds the spring setting, the disc is lifted off its seat, permitting flow through the control. When control pressure drops below the spring setting, the spring forces the control back to its normally closed position. The controlling pressure is applied to the chamber beneath the diaphragm through a sensing port on the CRL-60 body.

Pressure adjustment is simply a matter of turning the adjusting screw to vary the spring pressure on the diaphragm. The CRL-60 is available in six pressure ranges: 0 to 75 psi, 20 - 75 psi, 20 to 105 psi, 20 to 200 psi, 40 to 200 psi and 100 to 300 psi. To prevent tampering, the adjustment cap can be wire sealed by using the lock wire holes provided in the cap and cover; or supplied with a X140-1 Locking Cap. The X140-1 is a key and six-pin cylinder locking security cap that completely encapsulates the pilot control adjustment screw and cannot be removed without the appropriate key.

### Typical Application for CRL-60 Pressure Relief Control



50 Series Pressure Relief Control Valve

Model CRL-60 Pressure Relief Control is ideally suited as pilot control for Cla-Val Series 50 pressure relief or pressure sustaining automatic control valves. The 50 Series valves are hydraulically operated, pilot controlled, modulating type valves, used where pressure relief is needed in a waterworks pipeline distribution system downstream of any high pressure source, such as pressure reducing stations or pump stations, or they can also be used in a bypass to control pump delivery pressure.

Model CRL-60 is designed to maintain constant upstream pressure to close limits at a remote point in many Cla-Val pilot control systems. Cla-Val 50 Series Pressure Relief Valves use CRL-60 to sense and actuate main valve using inlet line pressure through pilot system. In event of a pressure surge in pipeline, CRL-60 remotely sensing valve inlet pressure opens quickly to control main valve opening and maintains water flow to atmosphere to dissipate pressure surge. CRL-60 closes slowly as the inlet pressure lowers to a safe pressure to prevent new surges, and finally when inlet pressure is below the pressure setting, the main valve closes drip tight. Pressure setting adjustment is made with a single adjusting screw that has a protective cap to discourage tampering.

## Specifications

<b>Size</b>	1/2", 3/4" & 1" Threaded
<b>Temperature Range</b>	Water, Air: to 180°F Max.
<b>Standard Materials</b>	
Body & Cover:	Low Lead Bronze
Trim:	Stainless Steel 303
Rubber:	Buna-N® Synthetic Rubber

<b>Pressure Ratings</b>	Bronze 400 psi Max. Stainless Steel 400 psi Max.
<b>Other Materials</b>	Available on special order
<b>Adjustment Ranges</b>	0 to 75 psi 20 to 75 psi (1" size only) 20 to 105 psi (1/2" size only) 20 to 200 psi 40 to 200 psi (1" size only) 100 to 300 psi

CRL-60 PSI	Approximate Increase For Each Clockwise Turn Of Adjusting Screw
0 to 75	8.5 psi
20 to 75	6.0 psi
20 to 105	12.0 psi
20 to 200	28.0 psi
40 to 200	18.0 psi
100 to 300	18.0 psi

### Pressure Drop Chart (Full Open Valve)

Valve Size	Cv Factor	Flow of Water - gpm					
		5	10	15	20	30	40
1/2"	6.0	0.7	2.7	6.0	11.0	--	--
3/4"	8.5	0.3	1.4	3.1	5.5	12.2	--
1"	12.5	0.2	0.6	1.4	2.6	5.8	10.2

### Dimensions 1/2" and 3/4" Sizes

0 to 75, 20 - 105 and 20 to 200 psi design

100 to 300 psi design

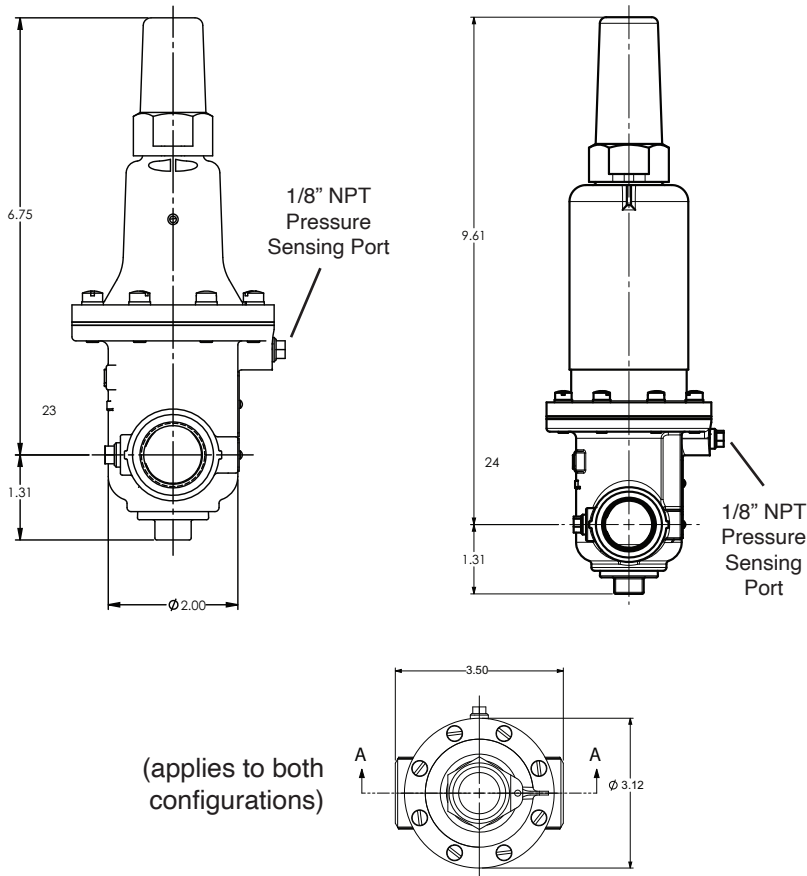

### Dimensions 1" Size

20 - 75, 40 - 200 and 100 - 300 psi design

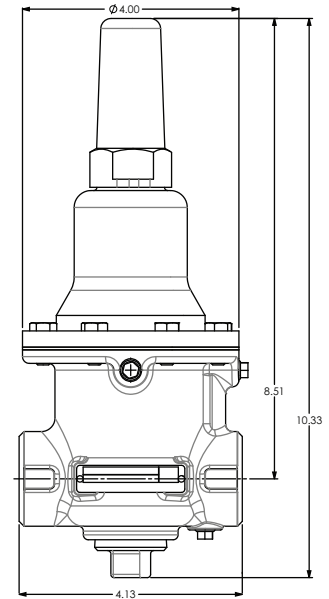

### When Ordering, Specify:

1. Catalog No. CRL-60
2. Valve Size
3. Adjustment Range Desired
4. Optional Materials
5. Optional Security Cap