



MODEL 60-19

Booster Pump Control Valve with High Capacity Pilot System



- Designed for Larger Sized Pump Stations
- Low Head Loss
- Built-in Check Valve
- Opening and Closing Rates Separately Adjusted
- Proven Reliable Design

The Cla-Val Model 60-19 Pump Control Valve is a pilot-operated valve designed for installation on the discharge of booster pumps to eliminate pipeline surges caused by the starting and stopping of the pump.

The pump starts against a closed valve. When the pump is started, the solenoid control is energized and the valve begins to open slowly, gradually increasing line pressure to full pumping head. When the pump is signaled to shut-off, the solenoid control is de-energized and the valve begins to close slowly, gradually reducing flow while the pump continues to run. When the valve is closed, a limit switch assembly, which serves as an electrical interlock between the valve and the pump, releases the pump starter and the pump stops.

Should a power failure occur, a built-in lift-type check valve closes the moment flow stops, preventing reverse flow regardless of solenoid or diaphragm assembly position.

Schematic Diagram

Item	Description
1	100-03 Powercheck Main Valve
2	CS3M Solenoid Control
3	102E 3-Way Valve
4	CVS-1 Shuttle Valve
5	X105LCW Switch Assembly
6	CV Flow Control

Optional Features

Item	Description
A	X46A Flow Clean Strainer
B	CK2 Isolation Valve
P	X141 Pressure Gauge
Y	X43 "Y" Strainer
PC	PC-22D Pump Control Panel

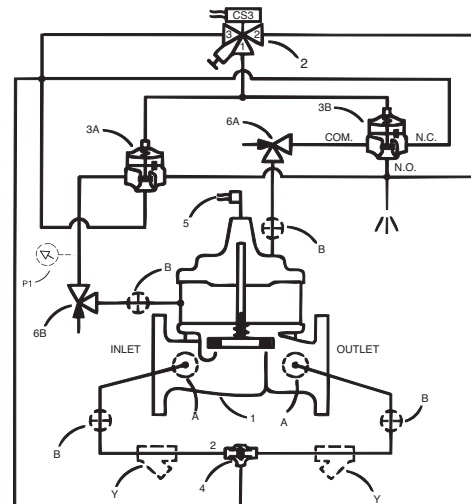

Typical Installation

Install Model 60-19 valve as shown. Flexible conduit should be used for electrical connections to the solenoid control and the limit switch. A Model 52-02/652-03 Surge Anticipator Valve is recommended for power failure protection.

Note: For optimum operation of built-in check feature, installation must be with valve stem vertically up.

The Model 60-19 is for 250mm and larger valves or when the pressure is above 300 psi.

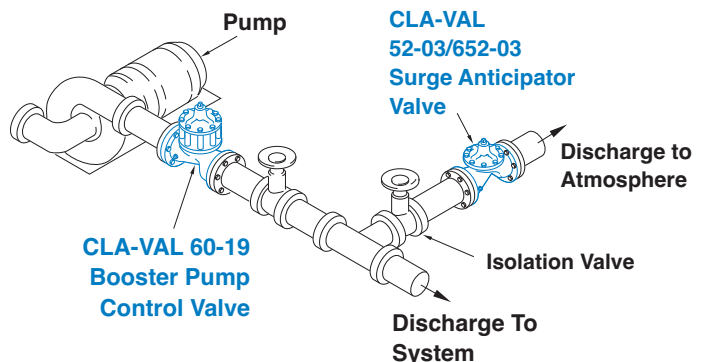

Pressure Ratings (Recommended Maximum Pressure - psi)

Valve Body & Cover		Pressure Class			
		Flanged			Threaded
Grade	Material	ANSI Standards*	150 Class	300 Class	End‡ Details
ASTM A536	Ductile Iron	B16.42	250	400	400
ASTM A216-WCB	Cast Steel	B16.5	285	400	400
UNS 87850	Bronze	B16.24	225	400	400

Note: * ANSI standards are for flange dimensions only.
 Flanged valves are available faced but not drilled.
 ‡ End Details machined to ANSI B2.1 specifications.
Valves for higher pressure are available; consult factory for details

Materials

Component	Standard Material Combinations		
Body & Cover	Ductile Iron	Cast Steel	Bronze
100-03 Available Sizes	250 - 400mm	250 - 400mm	250 - 400mm
Disc Retainer & Diaphragm Washer	Cast Iron	Cast Steel	Bronze
Trim: Disc Guide, Seat & Cover Bearing	Bronze is Standard Stainless Steel is Optional		
Disc	Buna-N® Rubber		
Diaphragm	Nylon Reinforced Buna-N® Rubber		
Stem, Nut & Spring	Stainless Steel		

For material options not listed, consult factory.
 Cla-Val manufactures valves in more than 55 different alloys.

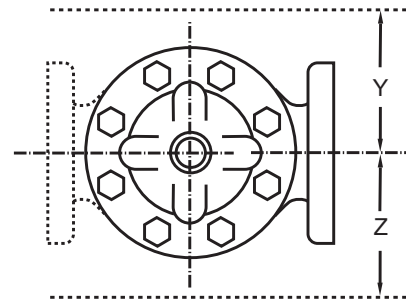
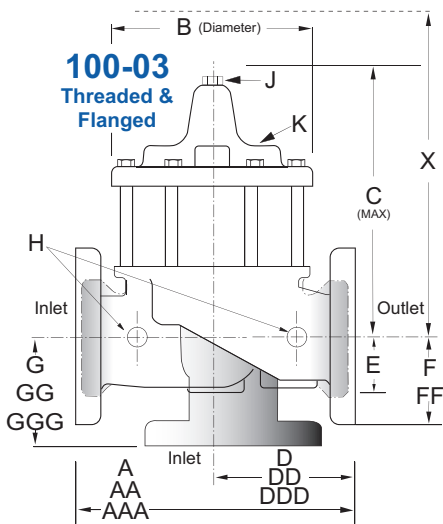

60-19 Series Dimensions (mm)

Valve Size (mm)	250	300	350	400
A Threaded	—	—	—	—
AA 150 ANSI	756	864	991	1051
AAA 300 ANSI	790	902	1029	1105
B Diameter	600	711	832	902
C Maximum	594	744	816	889
D Threaded	—	—	—	—
DD 150 ANSI	378	432	495	526
DDD 300 ANSI	395	451	514	552
E	235	273	321	394
F 150 ANSI	203	241	267	298
FF 300 ANSI	222	260	292	324
G Threaded	—	—	—	—
GG 150 ANSI	219	349	378	399
GGG 300 ANSI	236	368	397	419
H NPT Body Tapping	1.00	1.00	1.00	1.00
J NPT Cover Center Plug	1.00	1.25	1.50	2.00
K NPT Cover Tapping	1.00	1.00	1.00	1.00
Stem Travel	71	86	102	114
Approx. Ship Weight (kgs)	426	760	1116	1406
Approx. X Pilot System	762	940	1041	1092
Approx. Y Pilot System	508	559	610	660
Approx. Z Pilot System	508	559	610	660

Sequence Of Operation

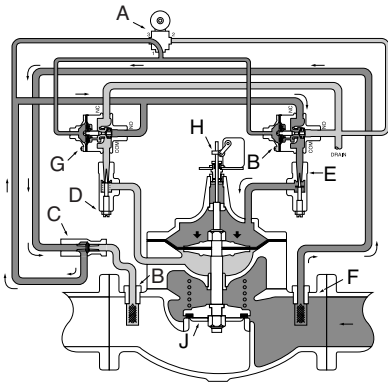

Pump Off...

With pump off, static line pressure is transmitted through strainer F, shuttle valve C, solenoid control A, three way valve B, and speed control E to the chamber above the diaphragm, thus holding the valve shut.

If power failure occurs when valve is open, the built-in check valve J closes immediately to prevent reverse flow.

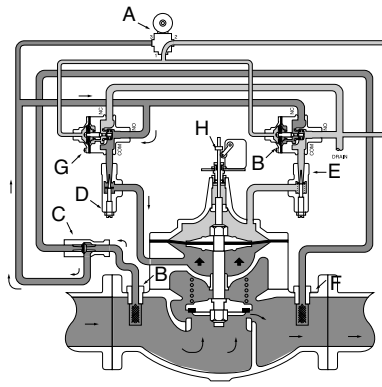

Starting Cycle...

Starting switch closes, pump starts, solenoid control A energizes and shifts allowing fluid from three-way valves G and B to drain to atmosphere. High pressure fluid from pump enters strainer B and shifts shuttle valve C, which always supplies the highest pressure from either strainer B or F. High pressure fluid is transmitted to the lower diaphragm chamber through three-way valve G and opens the valve. The opening speed of the valve is controlled by speed control E, which limits the rate fluid is relieved from above the diaphragm to drain.

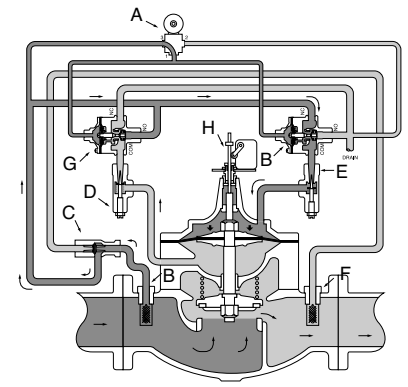

Stopping Cycle...

Starting switch opens, solenoid control A de-energizes and shifts, pump continues to run. High pressure fluid from the pump is directed above the diaphragm through three-way valve B to close the valve. The valve closes slowly as fluid from the lower diaphragm chamber is gradually released to atmosphere through speed control D and three-way valve G. When the valve closes fully, the limit switch H shuts off the pump.

Model 60-19 Flow Chart Uses 100-03 Powercheck Main Valve

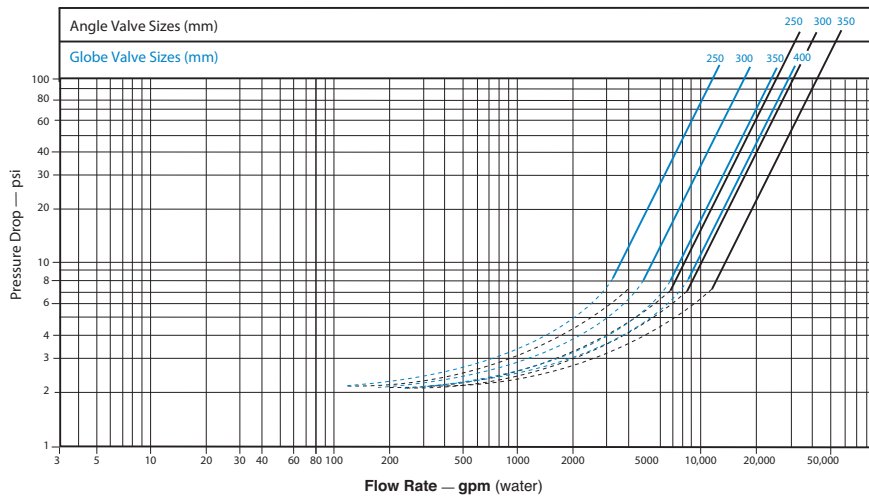

Liquid Volume Displaced from Diaphragm Chamber When Valve Opens or Closes				
Sizes (Inches)	250	300	350	400
60-19 (gallons)	2.51	4.00	6.50	9.57
660-19 (gallons)	1.26	2.51	4.00	6.50

Valve Sizing

Sizing Model 60-19 Booster Pump Control Valves is similar to sizing non-modulating type valves. Simply select the smallest size valve that will handle the pump output at an acceptable head loss for the application.

Do not oversize. Oversizing a Booster Pump Control Valve will nullify its ability to prevent surges caused by the starting and/or stopping of the pump. Maximum flow values are given in the selection table above. For further information on flow characteristics of this valve, see the 100-03 engineering data sheet.

Drain Provisions

Each time the valve opens or closes, water is discharged from the solenoid exhaust port, the amount varying with the valve size. Provisions should be made for the disposal of this water. Exhaust tube must be free of any back pressure. Provide an air gap between the solenoid exhaust tube and drain facility.

Cla-Val offers the most complete line of automatic control valves for virtually any type of pump control system available.

Please call your Cla-Val regional office or sales agent for complete design assistance. Our goal is to provide the best automatic control valve solution for each application.

60-19 Valve Selection	100-03 Pattern: Globe (G), Angle (A), End Connections: Threaded (T), Flanged (F) Indicate Available Sizes				
	mm	250	300	350	400
Main Valve 100-03	Pattern	G, A	G, A	G, A	G, A
	End Detail	F	F	F	F
Suggested Flow (Liters/Sec)	Maximum	309	442	530	694
	Maximum Intermittent	387	549	664	863
100-03 Series is the full internal port Powercheck.					

Pilot System Specifications

Temperature Range

Water to 180°F Max

Materials

Standard Pilot System Materials

Pilot Control: Low Lead Bronze

Trim: Stainless Steel Type 303

Rubber: Buna-N® Synthetic
Rubber

Optional Pilot System Materials

Pilot Systems are available with optional Aluminum, Stainless Steel or Monel materials.

Solenoid Control Specifications

Body:

Brass ASTM B283

Enclosure:

NEMA Type 1,2,3,3S,4,4X

general purpose watertight

NEMA Type 6,6P,7,9

watertight explosion proof
available.

Voltages:

110, 220 - 50 Hz AC

24, 120, 240, 480 - 60 Hz AC

6, 12, 24, 120, 240 - DC

Others available.

Max. operating pressure differential:

200 psi

Coil:

Insulation molded Class F

Watts AC 6

AC Volt Amps Inrush 30

AC Volt Amps Holding 16

Watts DC 10.6

Optional Electronic Control



The Cla-Val PC-22D provides control of the pump and pump control valve, preventing surges in the system when the pump starts or stops. It consists of a pre-wired electrical control panel employing a programmable valve controller to sequence the pump and pump control valve during all modes of operation. Provides added protection to the pumping system from damage caused by mechanical, hydraulic or power failure.

The PC-22D offers all the control features found in the recommended wiring diagrams for Cla-Val pump control valves, plus alarms, automatic shutdown and adjustable timers.

When Ordering, Please Specify:

1. Catalog No. 60-19
2. Valve Size
3. Pattern -Globe or Angle
4. Pressure Class
5. Trim Material
6. Electrical Selection
7. Desired Options
8. When Vertically Installed (Flow Direction)