



— MODEL — **60-11**

Booster Pump Control Valve



- **Built-in Check Valve**
- **Valve Uses Line Pressure for Operation**
- **Opening and Closing Rates Adjusted Separately**
- **Solenoid Control Can Be Operated Manually**
- **Can be integrated with SCADA when controlled by the PC-22D Electronic Pump Control Panel**

The Cla-Val Model 60-11 Booster Pump Control Valve is a pilot-operated valve designed for installation on the discharge of booster pumps to eliminate pipeline surges caused by the starting and stopping of the pump.

The pump starts against a closed valve. When the pump is started, the solenoid control is energized and the valve begins to open slowly, gradually increasing line pressure to full pumping head. When the pump is signaled to shut-off, the solenoid control is de-energized and the valve begins to close slowly, gradually reducing flow while the pump continues to run. When the valve is closed, a limit switch assembly, which serves as an electrical interlock between the valve and the pump, releases the pump starter and the pump stops.

Should a power failure occur, a built-in lift-type check valve closes the moment flow stops, preventing reverse flow regardless of solenoid or diaphragm assembly position.

Schematic Diagram

| Item | Description |
|------|------------------------------|
| 1 | 100-03 Powercheck Main Valve |
| 2 | CV Flow Control |
| 3 | CSM11-A2-2 Solenoid Control |
| 4 | X105LCW Switch Assembly |
| 5 | CVS-1 Shuttle Valve |

Optional Features

| Item | Description |
|------|---------------------------|
| A | X46A Flow Clean Strainer |
| B | CK2 Isolation Valve |
| P | X141 Pressure Gauge |
| Y | X43 "Y" Strainer |
| PC | PC-22D Pump Control Panel |

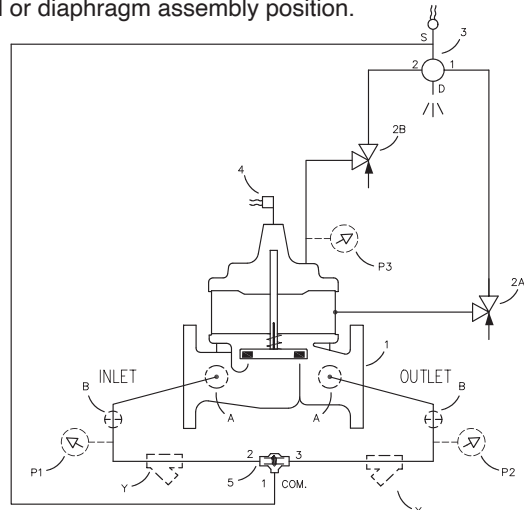

Typical Installation

Install the valve as shown to help prevent pipeline surges during pump starting and stopping. Flexible conduit should be used for electrical connections to the solenoid control and the limit switch. A Cla-Val Model 52-03 Surge Anticipator Valve is recommended for power failure protection or the Model 652-03 if a reduced port valve is required.

Use the PC-22D Electronic Pump Control Panel for applications where electronic control and integration with SCADA is desired.

Note: Installation with valve stem vertical up is recommended. For horizontal stem installation use Cla-Val Model 60-73 or, if a reduced port valve is required, Model 660-73.

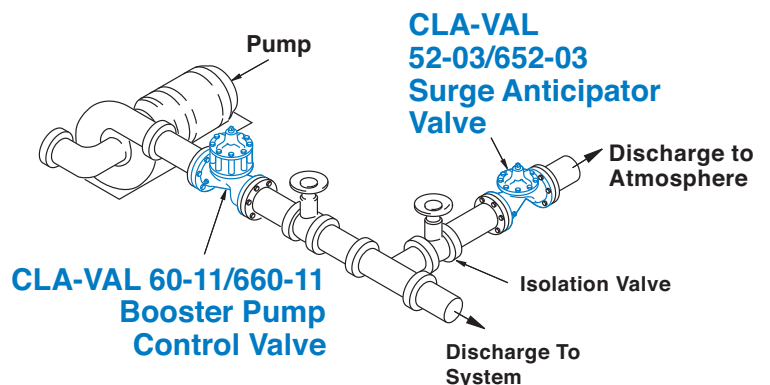

Pressure Ratings (Recommended Maximum Pressure - psi)

| Valve Body & Cover | | Pressure Class | | | |
|--------------------|--------------|-----------------|-----------|-----------|--------------|
| | | Flanged | | | Threaded |
| Grade | Material | ANSI Standards* | 150 Class | 300 Class | End‡ Details |
| ASTM A536 | Ductile Iron | B16.42 | 250 | 400 | 400 |
| ASTM A216-WCB | Cast Steel | B16.5 | 285 | 400 | 400 |
| UNS 87850 | Bronze | B16.24 | 225 | 400 | 400 |

Note: * ANSI standards are for flange dimensions only.
 Flanged valves are available faced but not drilled.
 ‡ End Details machined to ANSI B2.1 specifications.
Valves for higher pressure are available; consult factory for details

Materials

| Component | Standard Material Combinations | | |
|--|---|-------------|-------------|
| Body & Cover | Ductile Iron | Cast Steel | Bronze |
| 100-03 Available Sizes | 2-1/2" - 8" | 2-1/2" - 8" | 2-1/2" - 8" |
| Disc Retainer & Diaphragm Washer | Cast Iron | Cast Steel | Bronze |
| Trim: Disc Guide, Seat & Cover Bearing | Bronze is Standard Stainless Steel is Optional | | |
| Disc | Buna-N® Rubber | | |
| Diaphragm | Nylon Reinforced Buna-N® Rubber | | |
| Stem, Nut & Spring | Stainless Steel | | |

For material options not listed, consult factory.
 Cla-Val manufactures valves in more than 50 different alloys.

Model 60-11 (uses 100-03 Powercheck Main Valve)

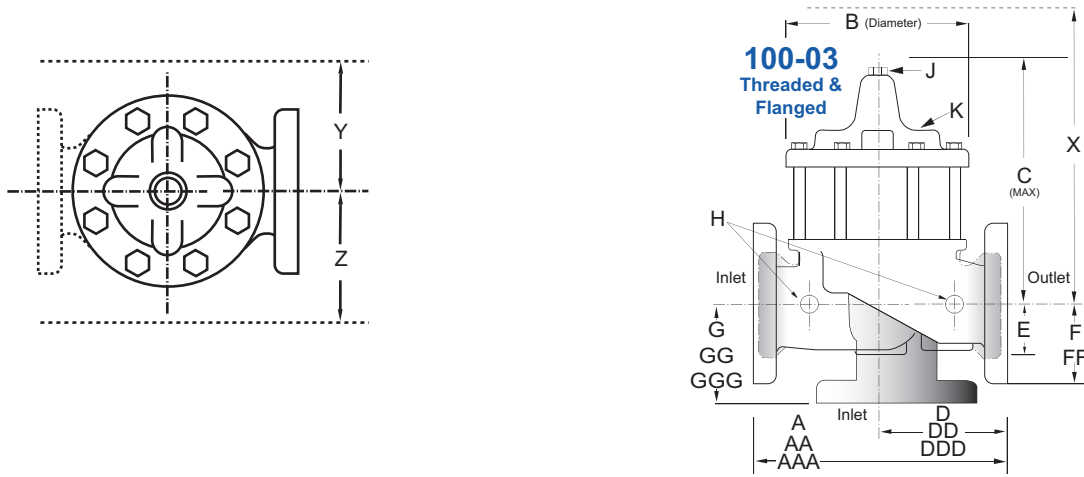

60-11 Series Dimensions (In Inches)

| Valve Size (Inches) | 2½ | 3 | 4 | 6 | 8 |
|---------------------------|-------|-------|-------|-------|-------|
| A Threaded | 11.00 | 12.50 | — | — | — |
| AA 150 ANSI | 11.00 | 12.00 | 15.00 | 20.00 | 25.38 |
| AAA 300 ANSI | 11.62 | 13.25 | 15.62 | 21.00 | 26.38 |
| B Diameter | 8.00 | 9.12 | 11.50 | 15.75 | 20.00 |
| C Maximum | 10.31 | 11.19 | 14.25 | 18.44 | 21.81 |
| D Threaded | 5.50 | 6.25 | — | — | — |
| DD 150 ANSI | 5.50 | 6.00 | 7.50 | 10.00 | 12.69 |
| DDD 300 ANSI | 5.81 | 6.63 | 7.81 | 10.50 | 13.19 |
| E | 1.69 | 2.06 | 3.19 | 4.31 | 5.31 |
| F 150 ANSI | 3.50 | 3.75 | 4.50 | 5.50 | 6.75 |
| FF 300 ANSI | 3.75 | 4.13 | 5.00 | 6.25 | 7.50 |
| G Threaded | 4.00 | 4.50 | — | — | — |
| GG 150 ANSI | 4.00 | 4.00 | 5.00 | 6.00 | 8.00 |
| GGG 300 ANSI | 4.31 | 4.38 | 5.31 | 6.50 | 8.50 |
| H NPT Body Tapping | 0.50 | 0.50 | 0.75 | 0.75 | 1.00 |
| J NPT Cover Center Plug | 0.50 | 0.50 | 0.75 | 0.75 | 1.00 |
| K NPT Cover Tapping | 0.50 | 0.50 | 0.75 | 0.75 | 1.00 |
| Stem Travel | 0.70 | 0.80 | 1.10 | 1.70 | 2.30 |
| Approx. Ship Weight (lbs) | 65 | 95 | 190 | 320 | 650 |
| Approx. X Pilot System | 14.00 | 15.00 | 17.00 | 29.00 | 31.00 |
| Approx. Y Pilot System | 10.00 | 11.00 | 12.00 | 20.00 | 22.00 |
| Approx. Z Pilot System | 10.00 | 11.00 | 12.00 | 20.00 | 22.00 |

| 60-11 Valve Selection | 100-03 Pattern: Globe (G), Angle (A), End Connections: Threaded (T), Flanged (F) Indicate Available Sizes | | | | | |
|-----------------------------------|---|------|------|------|------|------|
| | Inches | 2½ | 3 | 4 | 6 | 8 |
| | mm | 65 | 80 | 100 | 150 | 200 |
| Main Valve 100-03 | Pattern | G, A | G, A | G, A | G, A | G, A |
| | End Detail | T, F | T, F | F | F | F |
| Suggested Flow (gpm) | Maximum | 300 | 460 | 800 | 1800 | 3100 |
| | Maximum Intermittent | 370 | 580 | 990 | 2250 | 3900 |
| Suggested Flow (Liters/Sec) | Maximum | 19 | 29 | 50 | 113 | 195 |
| | Maximum Intermittent | 23 | 37 | 62 | 142 | 246 |

100-03 Series is the full internal port Powercheck

CSM11 Solenoid Control PowerConsumption

| Volts | Amperes | | Coil Resistance Ohms |
|------------|---------|--------|----------------------------|
| | Holding | Inrush | |
| AC 60 Hz | | | |
| 24 | 2.88 | 25.4 | 0.5 |
| 120 | .575 | 5.1 | 14.1 |
| 208 | .330 | 2.93 | 40 |
| 240 | .288 | 2.54 | 58 |
| 440 | .156 | 1.38 | 174 |
| 440 | .143 | 1.27 | 233 |
| | | | |
| Volts | Amperes | | Coil Resistance Ohms |
| (AC 50 Hz) | Holding | Inrush | |
| 110 | .48 | 4.6 | 15.7 |
| 220 | .24 | 2.3 | 66 |
| 240 | .22 | 2.1 | 88 |

How to Order

When Ordering, Specify:

1. Catalog No. 60-11
2. Valve Size
3. Pattern - Globe or Angle
4. Pressure Class
5. Trim Material
6. Electrical Selection
7. Desired Options
8. When Vertically Installed

CSM11 Specifications



Enclosure General purpose NEMA Type 3; Aluminum
Note: For other enclosures and NEMA Types, consult factory

Housing Body — Aluminum
Trim — Stainless Steel

Operating Pressure: Maximum pressure 300 psi, for higher pressure consult factory.

Coil Insulation Class A (molded)

AC voltage 15.4 watts

Pilot System Specifications

Temperature Range

Water to 180°F Max

Materials

Standard Pilot System Materials

Pilot Control: Low Lead Bronze

Trim: Stainless Steel Type 303

Rubber: Buna-N® Synthetic Rubber

Optional Pilot System Materials

Pilot Systems are available with optional Aluminum, Stainless Steel or Monel materials.

Optional Electronic Control



The Cla-Val PC-22D provides control of the pump and pump control valve, preventing surges in the system when the pump starts or stops. It consists of a pre-wired electrical control panel employing a programmable valve controller to sequence the pump and pump control valve during all modes of operation. Provides added protection to the pumping system from damage caused by mechanical, hydraulic or power failure.

The PC-22D offers all the control features found in the recommended wiring diagrams for Cla-Val pump control valves, plus alarms, automatic shutdown and adjustable timers.

Sequence Of Operation

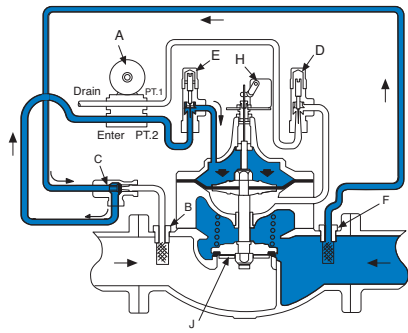

Pump Off...

With pump off, line pressure exists above the diaphragm holding the main valve closed.

Shuttle valve C always supplies highest pressure to solenoid control A through strainers B and F.

If power failure occurs when valve is open, the built-in check valve J closes immediately to prevent reverse flow.

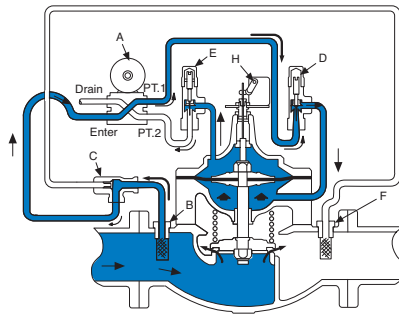

Starting Cycle...

Starting switch closes, pump starts, solenoid control energizes.

Upstream fluid flows to chamber below main valve diaphragm through strainer B, shuttle valve C, solenoid control A, and closing rate flow control D. Valve opens slowly as fluid from diaphragm chamber is gradually released to atmosphere through opening rate flow control E and solenoid control A.

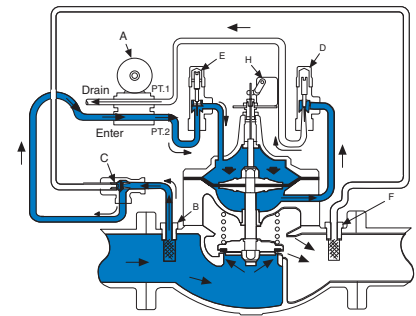

Stopping Cycle...

Starting switch opens, solenoid control de-energizes.

Upstream fluid flows to valve diagram through strainer B, shuttle valve C, solenoid control A and opening rate Flow Control E.

Valve closes slowly as fluid below diaphragm chamber is gradually released to atmosphere through closing rate flow control D and solenoid control A.

Model 60-11 Flow Chart (Uses 100-03 Powercheck Main Valve)

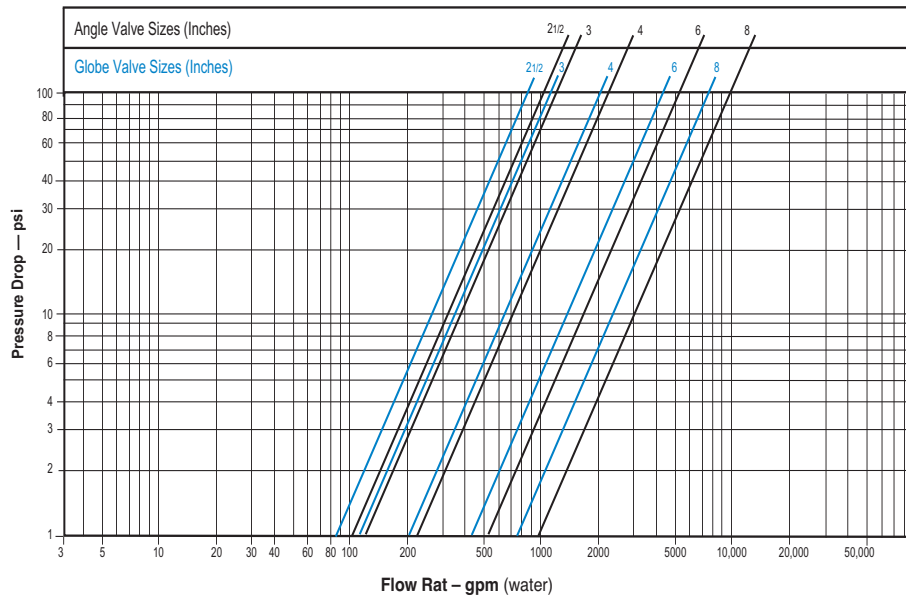

*** CONSULT FACTORY IF PRESSURE IS LESS THAN 10 PSI ***

| Liquid Volume Displaced from Diaphragm Chamber When Valve Opens or Closes | | | | | |
|---|----------|----------|----------|----------|----------|
| Sizes (Inches) | 2½" | 3" | 4" | 6" | 8" |
| 60-11 Displacement | .043 gal | .080 gal | .169 gal | .531 gal | 1.26 gal |

Valve Sizing

Sizing Model 60-11 Booster Pump Control Valves is similar to sizing non-modulating type valves. Simply select the smallest size valve that will handle the pump output at an acceptable head loss for the application.

Do not oversize. Oversizing a Booster Pump Control Valve will nullify its ability to prevent surges caused by the starting and/or stopping of the pump. Maximum flow values are given in the selection table above. Flow characteristics are shown on flow charts (over leaf) for these valve.

Example:

A booster pump with a rated output of 700 gpm and 4 psi is an acceptable head loss for the application. The flow chart for the 100-03 (60-11) indicates that a 8" globe valve has less than 4 psi pressure drop at 700 gpm.

Drain Provisions

Each time the valve opens or closes, water is discharged from the solenoid exhaust port, the amount varying with the valve size. Provisions should be made for the disposal of this water. Exhaust tube must be free of any back pressure. Provide an air gap between the solenoid exhaust tube and drain facility.