



— MODEL — **100-01KO-1**

# Anti-Cavitation Hytrol Valve



- Severe Service Design - High Pressure Differentials
- Reduced Noise and Vibration
- 316 Stainless Steel Disc Guide and Seat
- Drip-Tight, Positive Sealing
- Service Without Removal From Line
- Retrofit to Standard Hytrol Valves

The Cla-Val Model 100-01KO-1 Anti-Cavitation Hytrol is designed for applications where there is a high potential for damage from cavitation. Specify this valve series for a wide variety of control valve applications having pressure differentials up to 300 psid.

The 100-01KO-1 Hytrol main valve provides optimum internal pressure control through a unique anti-cavitation trim design. Constructed of 316 Stainless Steel, the seat and disc guide trim components feature dual interlocking sleeves. The seat contains variable flow apertures followed by a deflected to maximum pressure drop thru the seat at low valve positions. As valve position increases, the flow area increases thru the seat, maximizing the flow thru the valve. The seat center hole feature allows additional flow capacity thru the valve at higher valve positions. The disc guide features radial slots that deflect internal flow to impinge upon itself in the center of the flow path, harmlessly dissipating the potential for cavitation damage.

The 100-01KO-1 Hytrol is the basic valve used in Cla-Val Automatic Control Valves for high differential applications requiring remote control, pressure regulation, solenoid operation, rate of flow control, or level control.

The Anti-Cavitation Trim components can be retrofitted to existing valves if the application indicates an appropriate need. Please consult factory for details.

## Principle of Operation

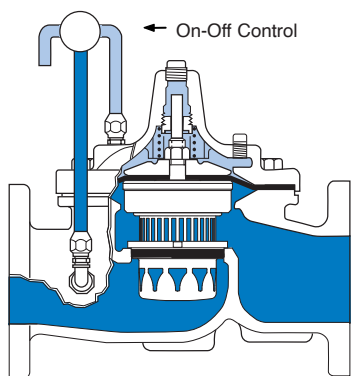

### Full Open Operation

When pressure in the cover chamber is relieved to a zone of lower pressure, the line pressure at the valve inlet opens the valve, allowing full flow.

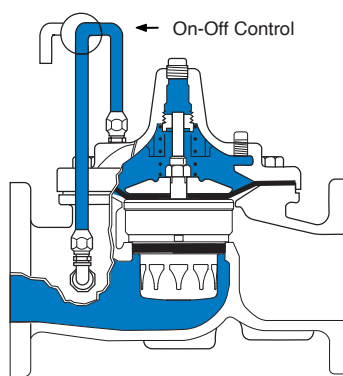

### Tight Closing Operation

When pressure from the valve inlet is applied to the cover chamber, the valve closes drip-tight.

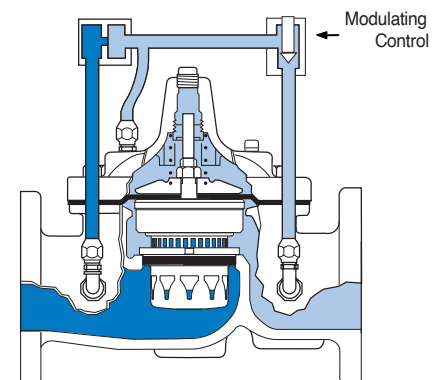

### Modulating Action

The valve holds any intermediate position when operating pressures are equal above and below the diaphragm. A Cla-Val "Modulating" Pilot Control will allow the valve to automatically compensate for line pressure changes.

# Specifications 100-01KO-1 Hytrol Valve with KO Anti-Cavitation Trim

## Patterns & End Connections

Pattern	Globe	Angle	Grooved End
Size	2" - 10" 50 - 250 mm	2" - 10" 50 - 250 mm	2" - 8" 50 - 200 mm

## Operating Temp. Range

Fluids
32 to 180 F

## Pressure Ratings (Recommended Maximum Pressure - psi)

Valve Body & Cover		Pressure Class				
		Flanged			Grooved	Threaded
Grade	Material	ANSI Standards*	150 Class	300 Class	300 Class	End‡ Details
ASTM A536	Ductile Iron	B16.42	250	400	400	400
ASTM A216-WCB	Cast Steel	B16.5	285	400	400	400
UNS 87850	Bronze	B16.24	225	400	400	400

Note: \* ANSI standards are for flange dimensions only.  
Flanged valves are available faced but not drilled.  
‡ End Details machined to ANSI B2.1 specifications.

## Materials

Component	Standard Material Combinations		
Body & Cover	Ductile Iron	Cast Steel	Bronze
Available Sizes	2" - 10" 50 - 250 mm	3" - 10" 32 - 250 mm	3" - 10" 32 - 250 mm
Disc Retainer & Diaphragm Washer	Cast Iron	Cast Steel	Bronze
Trim: Disc Guide, Seat & Cover Bearing	Stainless Steel is Standard		
Disc	Buna-N® Rubber		
Diaphragm	Nylon Reinforced Buna-N® Rubber		
Stem, Nut & Spring	Stainless Steel		

For material options not listed consult factory.

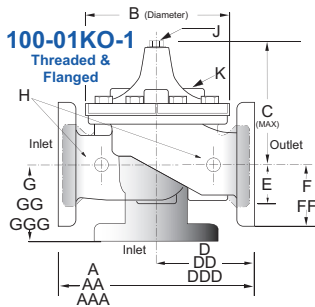

**Note:**  
Consult Factory  
on 10", 12", 16"  
angle pattern

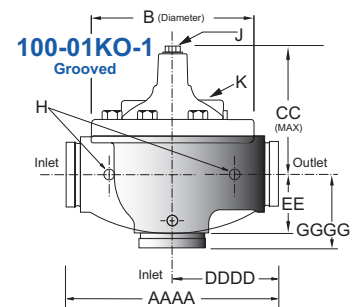
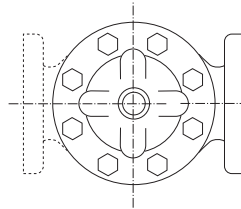

Valve Size (Inches)	2	2½	3	4	6	8	10
A Threaded	9.38	11.00	12.50	—	—	—	—
AA 150 ANSI	9.38	11.00	12.00	15.00	20.00	25.38	29.75
AAA 300 ANSI	10.00	11.62	13.25	15.62	21.00	26.38	31.12
AAAA Grooved End	9.00	11.00	12.50	15.00	20.00	25.38	—
B Diameter	6.62	8.00	9.12	11.50	15.75	20.00	23.62
C Maximum	6.50	7.56	8.19	10.62	13.38	16.00	17.12
CC Maximum Grooved End	5.75	6.88	7.25	9.31	12.12	14.62	—
D Threaded	4.75	5.50	6.25	—	—	—	—
DD 150 ANSI	4.75	5.50	6.00	7.50	10.00	12.69	14.88
DDD 300 ANSI	5.00	5.88	6.38	7.88	10.50	13.25	15.56
DDDD Grooved End	4.75	—	6.00	7.50	—	—	—
E	1.50	1.69	2.06	3.19	4.31	5.31	9.25
EE Grooved End	2.50	2.88	3.12	4.25	6.00	7.56	—
F 150 ANSI	3.00	3.50	3.75	4.50	5.50	6.75	8.00
FF 300 ANSI	3.25	3.75	4.13	5.00	6.25	7.50	8.75
G Threaded	3.25	4.00	4.50	—	—	—	—
GG 150 ANSI	3.25	4.00	4.00	5.00	6.00	8.00	8.62
GGG 300 ANSI	3.50	4.31	4.38	5.31	6.50	8.50	9.31
GGGG Grooved End	3.25	—	4.25	5.00	—	—	—
H NPT Body Tapping	0.375	0.50	0.50	0.75	0.75	1.00	1.00
J NPT Cover Center Plug	0.50	0.50	0.50	0.75	0.75	1.00	1.00
K NPT Cover Tapping	0.375	0.50	0.50	0.75	0.75	1.00	1.00
Stem Travel	0.60	0.70	0.80	1.10	1.70	2.30	2.80
Approx. Ship Weight (lbs)	35	50	70	140	285	500	780

Cla-Val Control Valves with KO ANTI-CAVITATION Trim operate with maximum efficiency when mounted in horizontal piping with the main valve cover Up. We recommend isolation valves be installed on inlet and outlet for maintenance. Adequate space above and around the valve for service personnel should be considered essential. A regular maintenance program should be established based on the specific application data. However, we recommend a thorough inspection be done at least once a year. Consult factory for specific recommendations.

## Functional Data

100-01KO-1 Valve Size		Inches	2	2½	3	4	6	8	10
		mm.	50	65	80	100	150	200	250
C <sub>v</sub> Factor	Globe Pattern	Gal./Min. (gpm.)	25	44	53	107	226	367	610
		Litres/Sec. (l/s.)	6	11	13	26	54	88	146
	Angle Pattern	Gal./Min. (gpm.)	30	47	56	112	240	393	640
		Litres/Sec. (l/s.)	7	11	13	27	57	94	153
Equivalent Length of Pipe	Globe Pattern	Feet (ft.)	272	268	460	476	810	1295	1430
		Meters (m.)	83	82	140	145	247	395	436
	Angle Pattern	Feet (ft.)	189	235	412	434	718	1129	1299
		Meters (m.)	58	72	126	132	219	344	396
K Factor	Globe Pattern		23	18	26	20	23	27	24
	Angle Pattern		16	16	23	18	20	24	22
Liquid Displaced from Cover Chamber When Valve Opens	U.S. Gal.	0.03	0.04	0.08	0.17	0.53	1.26	2.5	
	Litres	0.12	0.16	0.3	0.64	2	4.8	9.5	

For assistance in selecting appropriate valve options or valves manufactured with special design requirements, please contact our Regional Sales Office or Factory.

### C<sub>v</sub> Factor

Formulas for computing C<sub>v</sub> Factor, Flow (Q) and Pressure Drop (ΔP):

$$C_v = \frac{Q}{\sqrt{\Delta P}} \quad Q = C_v \sqrt{\Delta P} \quad \Delta P = \left( \frac{Q}{C_v} \right)^2$$

### K Factor (Resistance Coefficient)

The Value of K is calculated from the formula:  $K = \frac{894d^4}{C_v^2}$  (U.S. system units)

### Equivalent Length of Pipe

Equivalent lengths of pipe (L) are determined from the formula:  $L = \frac{Kd}{12f}$  (U.S. system units)

### Fluid Velocity

Fluid velocity can be calculated from the following formula:  $V = \frac{.4085 Q}{d^2}$  (U.S. system units)

### Where:

C<sub>v</sub> = U.S. (gpm) @ 1 psi differential at 60° F water  
or

C<sub>v</sub>-l/s = (l/s) @ 1 bar (14.5 PSIG) differential at 15° C water

d = inside pipe diameter of Schedule 40 Steel Pipe (inches)

f = friction factor for clean, new Schedule 40 pipe (dimensionless) (from Cameron Hydraulic Data, 18th Edition, P 3-119)

K = Resistance Coefficient (calculated)

L = Equivalent Length of Pipe (feet)

Q = Flow Rate in U.S. (gpm) or (l/s)

V = Fluid Velocity (feet per second) or (meters per second)

ΔP = Pressure Drop in (psi) or (bar)

### 100-01KO-1 ANTI-CAVITATION WIDE OPEN PRESSURE LOSS

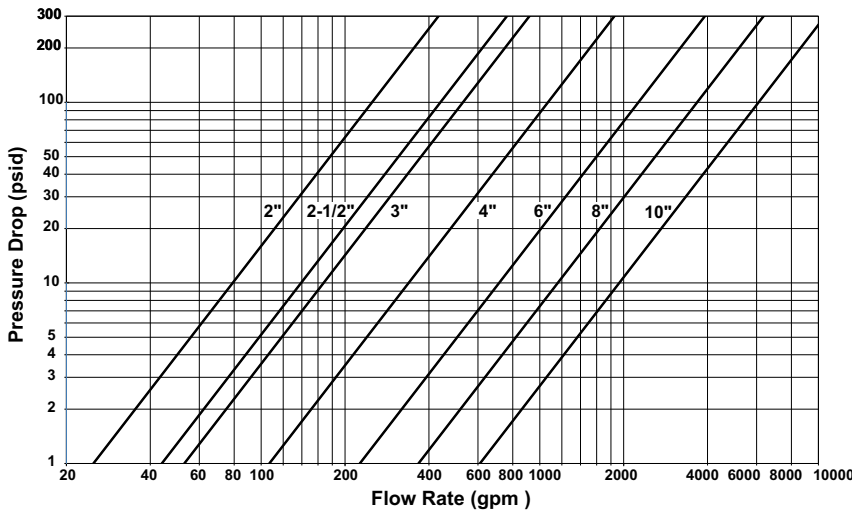

### SELECTION GUIDELINE FOR KO-1 ANTI-CAVITATION VALVES

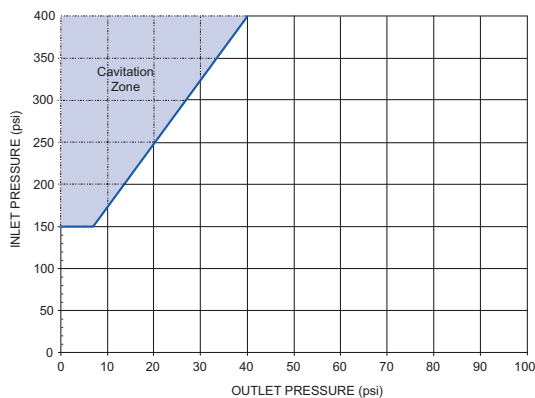

### Notes: On Operating Differential

1. For pressure differentials greater than 300 psi the maximum flow velocity should not exceed 18 ft/sec.
2. Flow velocities greater than 25 ft/sec are not recommended.
3. Recommended minimum flow velocity is 1 ft/sec.
4. For atmospheric discharge, consult factory.

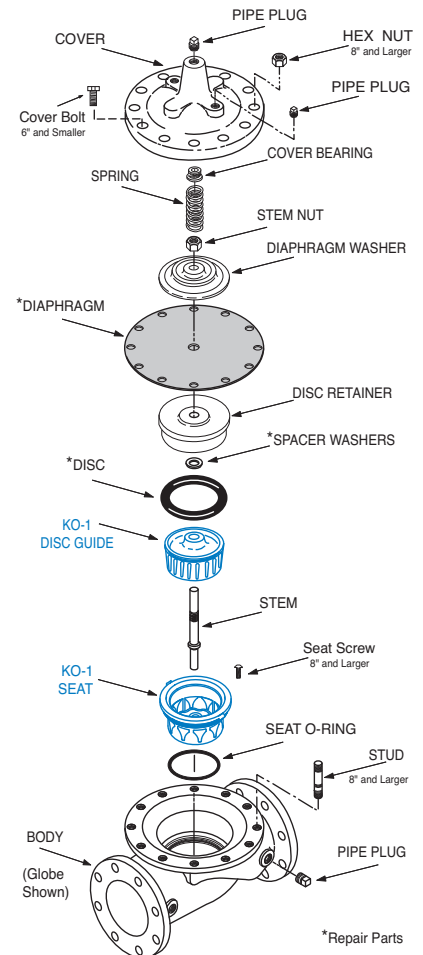

# 100-01KO-1 Hytrol Main Valve with Anti-Cavitation Trim Purchase Specifications

## Function

The valve shall be hydraulically operated, single diaphragm actuated, globe pattern. The valve shall consist of three major components: the body with seat installed, the cover with bearing installed, and the diaphragm assembly. The diaphragm assembly shall be the only moving part and shall form a sealed chamber in the upper portion of the valve, separating operating pressure from line pressure. Packing glands and/or stuffing boxes are not permitted and there shall be no pistons operating the main valve or pilot controls. Ductile Iron is standard, other materials shall be available. No fabrication or welding shall be used in the manufacturing process.

## Description

The anti-cavitation features of the seat shall have equally spaced variable flow apertures around the perimeter of the seat. A deflector feature shall be incorporated with a scallop profile at the top of the deflector surface, adding additional restriction and deflection to the fluid flow. The disc guide slots shall be positioned around the perimeter of the disc guide, configured and oriented in an angular direction so that fluid flow exiting through the slots is diverted away from direct impact with pressure boundary surfaces. Flow exiting the disc guide slots is directed in an angular path to increase the distance between the slot geometry and pressure boundary surfaces. If cavitation conditions exist, the increased distance between the slots and pressure boundary surfaces minimizes the potential for damage by allowing the cavitation bubbles to dissipate before they come in contact with pressure boundary surfaces. Anti-cavitation characteristics shall be controlled by the described variable aperture seat and disc guide components. The disc guide shall slide in the seat and allow controlled flow through the seat apertures into the central seat chamber where flow shall continue from the seat chamber and exit through the angularly oriented slots of the disc guide. The seat and disc guide features used together shall provide anti-cavitation characteristics suitable for applications where a large, controlled pressure drop is desired. The flexible, non-wicking, FDA approved diaphragm shall consist of nylon fabric bonded with synthetic rubber compatible with the operating fluid. The diaphragm must withstand a Mullins burst test of a minimum of 600 psi per layer of nylon fabric and shall be cycle tested 100,000 times to insure longevity. The diaphragm shall be fully supported in the valve body and cover by machined surfaces which support no less than one-half of the total surface area of the diaphragm in either the fully open or fully closed position. The valve seat in six inch and smaller size valves shall be threaded into the body. Valve seat in eight inch and larger size valves shall be retained by flat head machine screws for ease of maintenance. The seat shall be of the solid, one-piece design and shall have a minimum of a five degree taper on the seating surface for positive drip-tight shut-off. Pressed-in bearings and/or multi-piece seats shall not be permitted. To insure proper alignment of the valve stem, the valve body and cover shall be machined with a locating lip. No "pinned" covers to the valve body shall be permitted. All necessary repairs and/or modifications other than replacement of the main valve body shall be possible without removing the valve from the pipeline. The valve manufacturer shall warrant the valve to be free of defects in material and workmanship for a period of three years from date of shipment, provided the valve is installed and used in accordance with all applicable instructions. The valve manufacturer shall be able to supply a complete line of equipment from 2" through 10" sizes and a complete selection of complementary equipment.

## Material Specification

Valve Size:	Pressure Rating:
Main Valve Body and Cover:	Temperature Range:
Main Valve Trim:	Coating:
End Detail:	Desired Options:

## Application Information

Inlet/Outlet Pressures:  
Flow Rate:  
Pipe Diameter:  
Function (i.e. - Pressure Reducing, Pressure Relief, etc.):

This valve shall be a Cla-Val Model No. 100-01KO-1 Hytrol Main Valve with Anti-Cavitation Trim as manufactured by Cla-Val, Newport Beach, CA

**Note:** Add this Hytrol Anti-Cavitation Trim Purchase Specification to main valve specification for control valves where there is a high potential for cavitation damage. Please contact our Regional Sales Offices or Factory for assistance.

The Anti-Cavitation Trim components can be retrofitted to existing Hytrol valves if the application indicates an appropriate need. Please consult factory for details.



## CLA-VAL

1701 Placentia Avenue • Costa Mesa, CA 92627  
800-942-6326 • Web Site: [www.cla-val.com](http://www.cla-val.com) • E-mail: [info@cla-val.com](mailto:info@cla-val.com)

### CLA-VAL CANADA

4687 Christie Drive  
Beamsville, Ontario  
Canada L0R 1B4  
Phone: 905-563-4963  
[www.cla-val.com](http://www.cla-val.com)  
E-mail [sales@cla-val.ca](mailto:sales@cla-val.ca)

### CLA-VAL EUROPE

Chemin des Mésanges 1  
CH-1032 Romanel/  
Lausanne, Switzerland  
Phone: 41-21-643-15-55  
[www.cla-val.ch](http://www.cla-val.ch)  
E-mail: [info@cla-val.ch](mailto:info@cla-val.ch)

### CLA-VAL UK

Dainton House, Goods Station Road  
Tunbridge Wells  
Kent TN1 2 DH England  
Phone: 44-1892-514-400  
[www.cla-val.ch](http://www.cla-val.ch)  
E-mail: [info@cla-val.co.uk](mailto:info@cla-val.co.uk)

### CLA-VAL FRANCE

Porte du Grand Lyon 1  
ZAC du Champ du Périer  
France - 01700 Neyron  
Phone: 33-4-72-25-92-93  
[www.cla-val.ch](http://www.cla-val.ch)  
E-mail: [info@cla-val.ch](mailto:info@cla-val.ch)

### CLA-VAL ASIA PACIFIC

45 Kennaway Road  
Woolston, Christchurch, 8023  
New Zealand  
Phone: 64-39644860  
[www.cla-valpacific.com](http://www.cla-valpacific.com)  
E-mail: [info@cla-valpacific.com](mailto:info@cla-valpacific.com)