



# MODEL HV-100-25

## Angle Hose Valve



### Product Details

- Sensitive and Accurate Performance
- UL/ ULC Listed
- FM Approved

The Cla-Val 2 1/2" Model HV-100-25 features a Forged Brass finish body with Forgeline Bonnet and Seat Assembly.

A brass body is standard but can be supplied with a polished chrome, cast chrome or polished brass finish.

**Available hose threads include:** BCT, CSA, NSST, NPSH, NST, QST, WCT, Louisville, Cleveland, Chicago, Pittsburg, New Cincinnati, New York Corp, New York Fire Department, Richmond, and Raleigh

### Specifications

Cla-Val Model HV-100-25 UL/ULC Listed and FM Approved 300 psi (2070 kPa) pressure tested standard angle hose valve where standpipe pressure on a hose rack assembly or as a fire department outlet connection is less than 90 psi (620 kPa).

### Standards

#### NFPA 14

- Class II & III Standpipe Systems

### End Connection Options

- (1) Female NPT x Male Hose (Angle) - FM
- (2) Female NPT x Female NPT
- (3) Groove X Male Outlet

### Dimensions

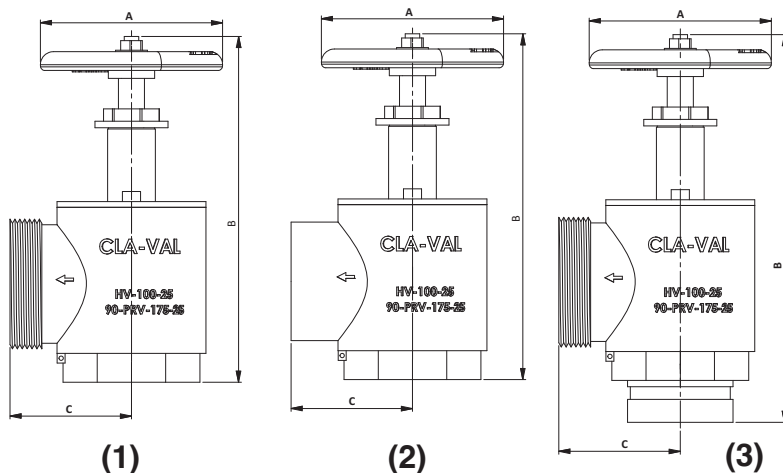

Dimensions	End Connection Type		
	1	2	3
A	5" 127 mm	5" 127 mm	5" 127 mm
B (open)	11" 279.4 mm	11" 279.4 mm	11-7/8" 301.6 mm
B (closed)	9-3/8" 238.1 mm	9-3/8" 238.1 mm	9-3/8" 238.1 mm
C	3-1/4" 82.5 mm	3-1/4" 82.5 mm	3-1/4" 82.5 mm