

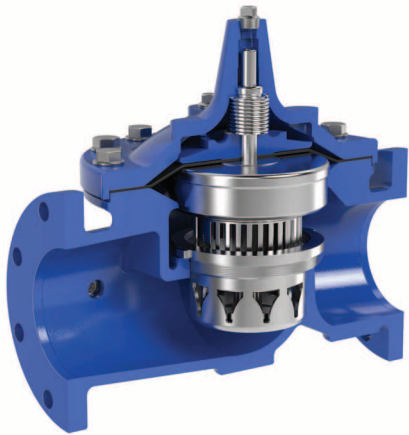

— MODEL — **100-01KO-1**

Anti-Cavitation Hytrol Valve



- Severe Service Design - High Pressure Differentials
- Reduced Noise and Vibration
- 316 Stainless Steel Disc Guide and Seat Standard
- Drip-Tight, Positive Sealing
- Service Without Removal From Line
- Retrofit to Standard Hytrol Valves

The Cla-Val Model 100-01KO-1 Anti-Cavitation Hytrol Valve is designed for applications where there is a high potential for damage from cavitation. Specify this valve series for a wide variety of control valve applications having pressure differentials up to 300 psid or for relief valves having atmospheric discharge up to 150 psid.

The 100-01KO-1 Hytrol main valve provides optimum internal pressure control through a unique anti-cavitation trim design. Constructed of 316 Stainless Steel, the seat and disc guide trim components feature dual interlocked sleeves containing radial slots that deflect internal flow to impinge upon itself in the center of the flow path, harmlessly dissipating the potential cavitation damage. This unique design also lessens the possibility of fouling if large particles in the water are present due to the large flow path of the radial slots.

The 100-01KO-1 Hytrol is the basic valve used in Cla-Val Automatic Control Valves for high differential applications requiring remote control, pressure regulation, solenoid operation, rate of flow control, or liquid level control.

The Anti-Cavitation Trim components can be retrofitted to existing valves if the application indicates an appropriate need. Please consult factory for details.

Principle of Operation

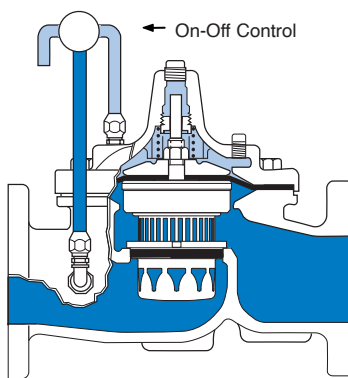

Full Open Operation

When pressure in the cover chamber is relieved to a zone of lower pressure, the line pressure at the valve inlet opens the valve, allowing full flow.

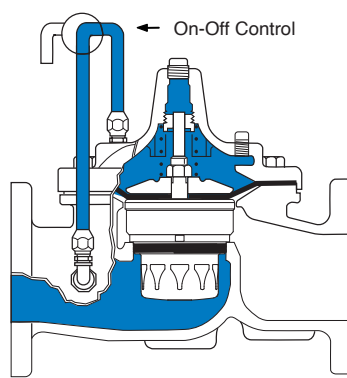

Tight Closing Operation

When pressure from the valve inlet is applied to the cover chamber, the valve closes drip-tight.

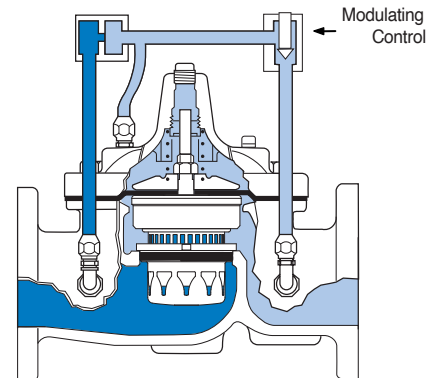

Modulating Action

The valve holds any intermediate position when operating pressures are equal above and below the diaphragm. A Cla-Val "Modulating" Pilot Control will allow the valve to automatically compensate for line pressure changes.

Specifications 100-01KO-1 Hytrol Valve with KO Anti-Cavitation Trim

Patterns & End Connections

Pattern	Globe	Angle	Grooved End
Size	2" - 10" 50 - 250 mm	2" - 10" 50 - 250 mm	2" - 8" 50 - 200 mm

Operating Temp. Range

Fluids
32 to 180 F

Pressure Ratings (Recommended Maximum Pressure - psi)

Valve Body & Cover		Pressure Class				
		Flanged			Grooved	Threaded
Grade	Material	ANSI Standards*	150 Class	300 Class	300 Class	End‡ Details
ASTM A536	Ductile Iron	B16.42	250	400	400	400
ASTM A216-WCB	Cast Steel	B16.5	285	400	400	400
UNS 87850	Bronze	B16.24	225	400	400	400

Note: * ANSI standards are for flange dimensions only.
Flanged valves are available faced but not drilled.
‡ End Details machined to ANSI B2.1 specifications.

Materials

Component	Standard Material Combinations		
Body & Cover	Ductile Iron	Cast Steel	Bronze
Available Sizes	2" - 10" 50 - 250 mm	3" - 10" 32 - 250 mm	3" - 10" 32 - 250 mm
Disc Retainer & Diaphragm Washer	Cast Iron	Cast Steel	Bronze
Trim: Disc Guide, Seat & Cover Bearing	Stainless Steel is Standard		
Disc	Buna-N® Rubber		
Diaphragm	Nylon Reinforced Buna-N® Rubber		
Stem, Nut & Spring	Stainless Steel		

For material options not listed consult factory.

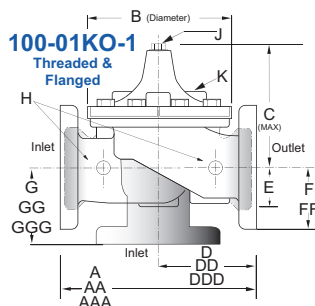

Note:
Consult Factory on
250, 300 & 400 mm
angle pattern

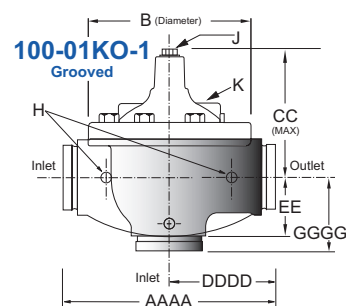
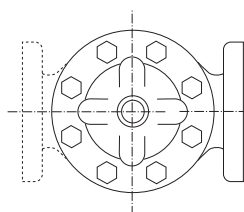

Valve Size (mm)	50	65	80	100	150	200	250
A Threaded	238	279	318	—	—	—	—
AA 150 ANSI	238	279	305	381	508	645	756
AAA 300 ANSI	254	295	337	397	533	670	790
AAAA Grooved End	228	279	318	381	508	645	—
B Diameter	168	203	232	292	400	508	600
C Maximum	165	192	208	270	340	406	435
CC Maximum Grooved End	146	175	184	236	308	371	—
D Threaded	121	140	159	—	—	—	—
DD 150 ANSI	121	140	152	191	254	322	378
DDD 300 ANSI	127	149	162	200	267	337	395
DDDD Grooved End	121	—	152	191	—	—	—
E	38	43	52	81	110	135	235
EE Grooved End	64	73	79	108	152	192	—
F 150 ANSI	76	89	95	114	140	171	203
FF 300 ANSI	83	95	105	127	159	191	222
G Threaded	83	102	114	—	—	—	—
GG 150 ANSI	83	102	102	127	152	203	219
GGG 300 ANSI	89	110	111	135	165	216	236
GGGG Grooved End	83	—	108	127	—	—	—
H NPT Body Tapping	0.375	0.50	0.50	0.75	0.75	1.00	1.00
J NPT Cover Center Plug	0.50	0.50	0.50	0.75	0.75	1.00	1.00
K NPT Cover Tapping	0.375	0.50	0.50	0.75	0.75	1.00	1.00
Stem Travel	15	18	20	28	43	58	71
Approx. Ship Weight (kgs)	16	23	32	64	129	227	354

Cla-Val Control Valves with KO ANTI-CAVITATION Trim operate with maximum efficiency when mounted in horizontal piping with the main valve cover Up. We recommend isolation valves be installed on inlet and outlet for maintenance. Adequate space above and around the valve for service personnel should be considered essential. A regular maintenance program should be established based on the specific application data. However, we recommend a thorough inspection be done at least once a year. Consult factory for specific recommendations.

Functional Data

100-01KO-1 Valve Size		Inches	2	2½	3	4	6	8	10
		mm.	50	65	80	100	150	200	250
C _V Factor	Globe Pattern	Gal./Min. (gpm.)	30.6	41.8	51.8	101.2	215.3	350.1	633.7
		Litres/Sec. (l/s.)	7	10	12	24	52	84	152
	Angle Pattern	Gal./Min. (gpm.)	32.3	44.5	56.4	108.8	228.3	374.3	664.2
		Litres/Sec. (l/s.)	8	11	13	26	55	90	159
Equivalent Length of Pipe	Globe Pattern	Feet (ft.)	182	297	482	532	893	1423	1325
		Meters (m.)	55	91	147	162	272	434	404
	Angle Pattern	Feet (ft.)	163	262	407	460	794	1245	1206
		Meters (m.)	50	80	124	140	242	380	368
K Factor	Globe Pattern		15	20	27	22	25	30	22
	Angle Pattern		14	18	23	19	22	26	20
Liquid Displaced from Cover Chamber When Valve Opens	U.S. Gal.		0.03	0.04	0.08	0.17	0.53	1.26	2.5
	Litres		0.12	0.16	0.3	0.64	2	4.8	9.5

For assistance in selecting appropriate valve options or valves manufactured with special design requirements, please contact our Regional Sales Office or Factory.

C_V Factor

Formulas for computing C_V Factor, Flow (Q) and Pressure Drop (ΔP):

$$C_V = \frac{Q}{\sqrt{\Delta P}} \quad Q = C_V \sqrt{\Delta P} \quad \Delta P = \left(\frac{Q}{C_V}\right)^2$$

K Factor (Resistance Coefficient)

The Value of K is calculated from the formula: $K = \frac{894d^4}{C_V^2}$ (U.S. system units)

Equivalent Length of Pipe

Equivalent lengths of pipe (L) are determined from the formula: $L = \frac{Kd}{12f}$ (U.S. system units)

Fluid Velocity

Fluid velocity can be calculated from the following formula: $V = \frac{.4085 Q}{d^2}$ (U.S. system units)

Where:

C_V = U.S. (gpm) @ 1 psi differential at 60° F water
or

C_V-l/s = (l/s) @ 1 bar (14.5 PSIG) differential at 15° C water

d = inside pipe diameter of Schedule 40 Steel Pipe (inches)

f = friction factor for clean, new Schedule 40 pipe (dimensionless) (from Cameron Hydraulic Data, 18th Edition, P 3-119)

K = Resistance Coefficient (calculated)

L = Equivalent Length of Pipe (feet)

Q = Flow Rate in U.S. (gpm) or (l/s)

V = Fluid Velocity (feet per second) or (meters per second)

ΔP = Pressure Drop in (psi) or (bar)

100-01KO-1 ANTI-CAVITATION WIDE OPEN PRESSURE LOSS

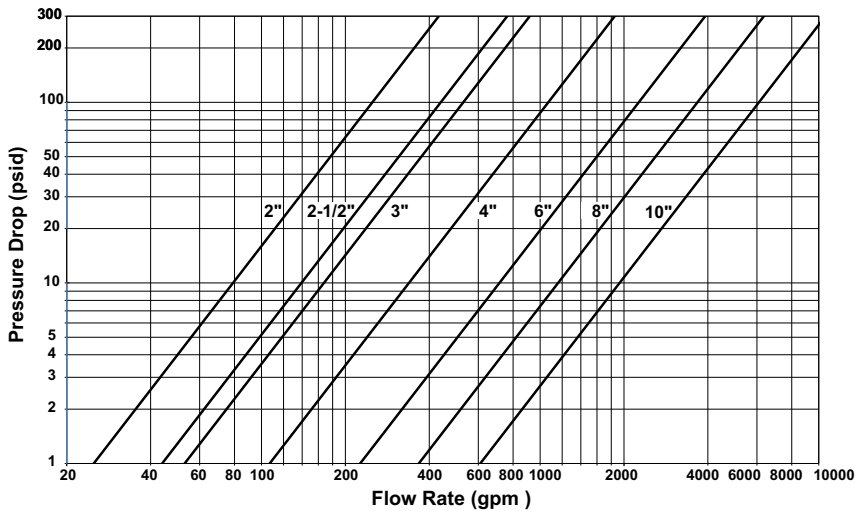

SELECTION GUIDELINE FOR KO-1 ANTI-CAVITATION VALVES

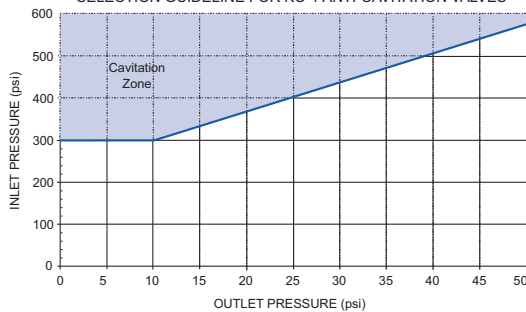

Notes: On Operating Differential

- For pressure differentials greater than 300 psi the maximum flow velocity should not exceed 18 ft/sec.
- Flow velocities greater than 25 ft/sec are not recommended.
- Recommended minimum flow velocity is 1 ft/sec.
- For atmospheric discharge, consult factory.

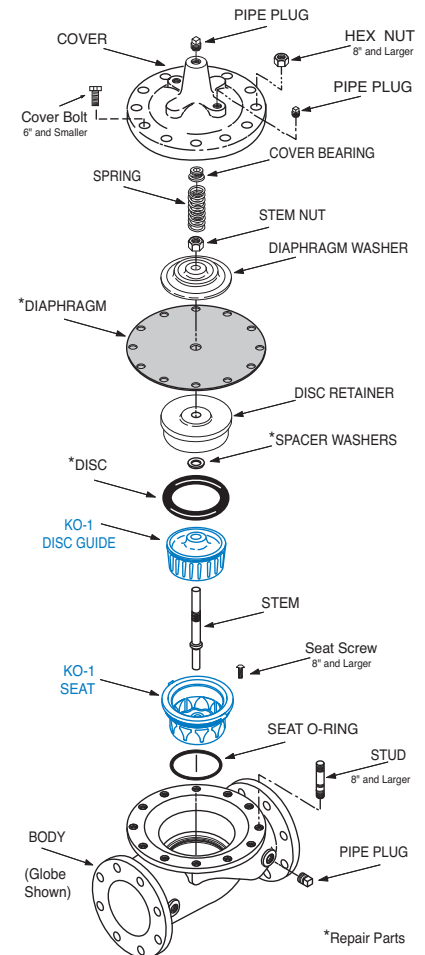

100-01KO-1 Hytrol Main Valve with Anti-Cavitation Trim Purchase Specifications

Function

The valve shall be hydraulically operated, single diaphragm actuated, globe pattern. The valve shall consist of three major components: the body with seat installed, the cover with bearing installed, and the diaphragm assembly. The diaphragm assembly shall be the only moving part and shall form a sealed chamber in the upper portion of the valve, separating operating pressure from line pressure. Packing glands and/or stuffing boxes are not permitted and there shall be no pistons operating the main valve or pilot controls. Ductile Iron is standard, other materials shall be available. No fabrication or welding shall be used in the manufacturing process.

Description

The anti-cavitation features of the seat shall have equally spaced variable flow apertures around the perimeter of the seat. A deflector feature shall be incorporated with a scallop profile at the top of the deflector surface, adding additional restriction and deflection to the fluid flow. The disc guide slots shall be positioned around the perimeter of the disc guide, configured and oriented in an angular direction so that fluid flow exiting through the slots is diverted away from direct impact with pressure boundary surfaces. Flow exiting the disc guide slots is directed in an angular path to increase the distance between the slot geometry and pressure boundary surfaces. If cavitation conditions exist, the increased distance between the slots and pressure boundary surfaces minimizes the potential for damage by allowing the cavitation bubbles to dissipate before they come in contact with pressure boundary surfaces. Anti-cavitation characteristics shall be controlled by the described variable aperture seat and disc guide components. The disc guide shall slide in the seat and allow controlled flow through the seat apertures into the central seat chamber where flow shall continue from the seat chamber and exit through the angularly oriented slots of the disc guide. The seat and disc guide features used together shall provide anti-cavitation characteristics suitable for applications where a large, controlled pressure drop is desired. The flexible, non-wicking, FDA approved diaphragm shall consist of nylon fabric bonded with synthetic rubber compatible with the operating fluid. The diaphragm must withstand a Mullins burst test of a minimum of 600 psi per layer of nylon fabric and shall be cycle tested 100,000 times to insure longevity. The diaphragm shall be fully supported in the valve body and cover by machined surfaces which support no less than one-half of the total surface area of the diaphragm in either the fully open or fully closed position. The valve seat in six inch and smaller size valves shall be threaded into the body. Valve seat in eight inch and larger size valves shall be retained by flat head machine screws for ease of maintenance. The seat shall be of the solid, one-piece design and shall have a minimum of a five degree taper on the seating surface for positive drip-tight shut-off. Pressed-in bearings and/or multi-piece seats shall not be permitted. To insure proper alignment of the valve stem, the valve body and cover shall be machined with a locating lip. No "pinned" covers to the valve body shall be permitted. All necessary repairs and/or modifications other than replacement of the main valve body shall be possible without removing the valve from the pipeline. The valve manufacturer shall warrant the valve to be free of defects in material and workmanship for a period of three years from date of shipment, provided the valve is installed and used in accordance with all applicable instructions. The valve manufacturer shall be able to supply a complete line of equipment from 2" through 10" sizes and a complete selection of complementary equipment.

Material Specification

Valve Size:	Pressure Rating:
Main Valve Body and Cover:	Temperature Range:
Main Valve Trim:	Coating:
End Detail:	Desired Options:

Application Information

Inlet/Outlet Pressures:
Flow Rate:
Pipe Diameter:
Function (i.e. - Pressure Reducing, Pressure Relief, etc.):

This valve shall be a Cla-Val Model No. 100-01KO-1 Hytrol Main Valve with Anti-Cavitation Trim as manufactured by Cla-Val, Newport Beach, CA

Note: Add this Hytrol Anti-Cavitation Trim Purchase Specification to main valve specification for control valves where there is a high potential for cavitation damage. Please contact our Regional Sales Offices or Factory for assistance.

The Anti-Cavitation Trim components can be retrofitted to existing Hytrol valves if the application indicates an appropriate need. Please consult factory for details.



E-100-01KO-1 Metric (R-10/2022)

CLA-VAL

1701 Placentia Avenue • Costa Mesa, CA 92627
800-942-6326 • Web Site: www.cla-val.com • E-mail: info@cla-val.com

CLA-VAL CANADA

4687 Christie Drive
Beamsville, Ontario
Canada L0R 1B4
Phone: 905-563-4963
www.cla-val.com
E-mail sales@cla-val.ca

CLA-VAL EUROPE

Chemin des Mésanges 1
CH-1032 Romanel/
Lausanne, Switzerland
Phone: 41-21-643-15-55
www.cla-val.ch
E-mail: info@cla-val.ch

CLA-VAL UK

Dainton House, Goods Station Road
Tunbridge Wells
Kent TN1 2 DH England
Phone: 44-1892-514-400
www.cla-val.ch
E-mail: info@cla-val.co.uk

CLA-VAL FRANCE

Porte du Grand Lyon 1
ZAC du Champ du Pèrier
France - 01700 Neyron
Phone: 33-4-72-25-92-93
www.cla-val.ch
E-mail: info@cla-val.ch

CLA-VAL ASIA PACIFIC

45 Kennaway Road
Woolston, Christchurch, 8023
New Zealand
Phone: 64-39644860
www.cla-valpacific.com
E-mail: info@cla-valpacific.com

© COPYRIGHT CLA-VAL Printed in USA Specifications subject to change without notice.

visit www.cla-val-latinamerica.com for Spanish literature