



MODEL — **136-03/636-03**

Solenoid Control Valve

INTRODUCTION

The Cla-Val Model 136-03/636-03 Solenoid Control Valve is an automatic valve designed to either close drip tight or open fully by means of a Three-Way Solenoid Control. It is a hydraulically operated, solenoid controlled, diaphragm type globe or angle valve.

INSTALLATION

1. Allow sufficient room around the valve assembly to make adjustments and for disassembly.

Note: Before the valve is installed, the pipeline should be flushed to remove all chips, scale and foreign matter.

- It is recommended that gate or line block valves be installed upstream and downstream of the Model 136-03/636-03 to facilitate isolating the valve for preventive maintenance.
- Place the valve in the line with flow in the direction of flow arrows or by the inlet nameplate. Check all fittings and hardware for proper makeup and that no apparent damage is evident. Be sure main valve cover nuts/bolts are tight. Pressure in some applications can be very high so be thorough in checking and inspecting for proper installation and makeup.
- Cla-Val Valves operate with maximum efficiency when mounted in horizontal piping with the cover UP; however, other positions are acceptable. Due to size and weight of cover and internal components of six inch valves and larger, installation with the cover up is advisable. This makes periodic inspection of internal parts readily accessible.
- Caution must be taken in the installation of this valve to insure that galvanic and/or electrolytic action does not take place. The proper use of dielectric fittings and gaskets are required in all systems using dissimilar metals.
- Comply with local and national electrical codes when wiring the Solenoid Control.

OPERATION AND START-UP

1. Prior to pressurizing the valve assembly make sure the necessary gauges to measure pressure in the system are installed as required by the system engineer. A Cla-Val Model X101 Valve Position Indicator can be installed in the center cover port to provide visual indication of the valve diaphragm assembly position during start-up.

CAUTION: During start-up and test procedures a large volume of water may be discharged downstream. Check that the downstream venting is adequate to prevent damage to personnel and equipment. If the main valve closes too fast it may cause surging in upstream piping.

2. If isolation valves (B) are installed in pilot system open these valves. (see schematic).

3. The three-way Solenoid Control applies or relieves pressure in the 102E three-way valve cover chamber. This, in turn, applies or relieves pressure in the main valve cover chamber. The following action takes place:

SOLENOID CONTROL(2)		ENERGIZED To OPEN 136-03 SERIES		DE-ENERGIZED To OPEN 136-03 SERIES	
POSITION	FLOW	THREE-WAY VALVE FLOW(3)	MAIN VALVE (1)	THREE-WAY VALVE FLOW(3)	MAIN VALVE 1
ENERGIZED	1 TO 2	COM. TO N.O.	OPEN	N.C. TO COM.	CLOSED
DE-ENERGIZED	3 TO 1	N.C. TO COM.	CLOSED	COM. TO N.O.	OPEN

Note: Solenoids are not reversible because of different internal construction between Energize to open and De-energize to open solenoids.



- Check that solenoid (2) is set to close main valve. Slowly open the gate or block valve upstream of the valve.
- Carefully loosen tube fittings at highest points and bleed air from system. Carefully loosen the plug at top of main valve cover. If X101 Valve Position Indicator is installed, carefully open the bleed valve at top of Indicator. Bleed air from cover and tighten plug or bleed screw. Tighten tube fittings.
- Slowly open downstream gate or block valve. Check the operation of the valve by energizing and de-energizing the solenoid. The valve should open fully and close drip tight. Need minimum 5 psi differential under flowing conditions.

MAINTENANCE

- Cla-Val Valves and Controls require no lubrication or packing and a minimum of maintenance. However, a periodic inspection schedule should be established to determine how the fluid handled is affecting the efficiency of the valve assembly. Minimum of once per year.
- Repair and adjustment procedures of the Cla-Val Hytrol main valve and control components are included in a more detailed IOM manual. It can be downloaded from our web site (www.cla-val.com) or by contacting a Cla-Val Regional Sales Office.
- When ordering parts always refer to the catalog number and stock number on the valve nameplate.**

SYMPTON	PROBABLE CAUSE	REMEDY
Main Valve Fails to Close	No flow condition	Inspect downstream piping for closed valve or obstruction
	Too low pressure differential across valve Need minimum 5psi differential under flow conditions	Restrict valve opening with Cla-Val X102A limiting assembly (Contact Cla-Val)
	Closed isolation valves in pilot system, or in main line	Open valves
	Lack of cover chamber pressure	Check upstream pressure, tubing needle valves for restriction
	Diaphragm damaged	Replac diaphragm
	Mechanical obstruction Object lodged in valve Worn disc	Remove obstruction Replace disc
	Badly scored seat	Replace seat
Main Valve Fails to Open	CNA needle valve closed	Open this speed control to allow pressure to cover
	Closed isolation valves in pilot system, or in main line Insufficient line pressure Diaphragm assembly inoperative	Open valves Clean & polish stem Replace and defective or damaged parts
	Air in cover	Bleed all air from valve
Main Valve Vibrates when Closed	Air in cover	Bleed all air from valve

136-03/636-03 SCHEMATIC

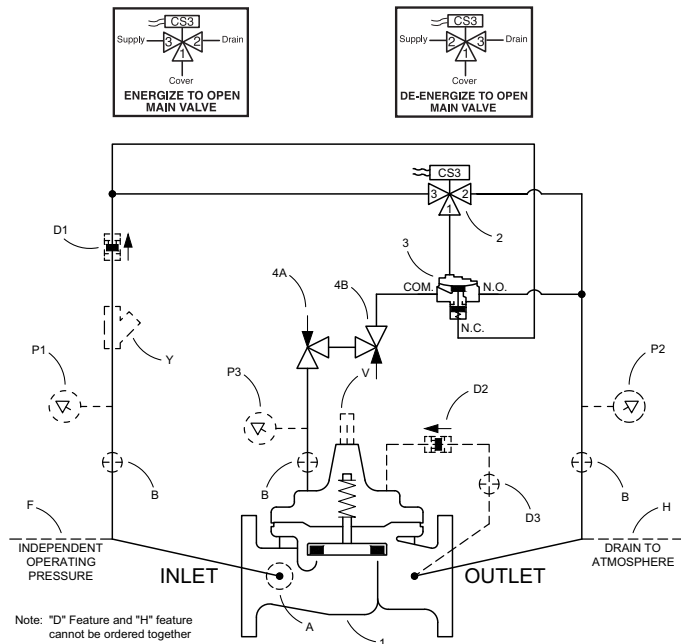

BASIC COMPONENTS

- 1 100-01 Hytrol (Main Valve)
- 100-20 600 Series Hytrol (Main Valve)
- 2 CS3 Solenoid Control
- 3 102E Three-Way Valve
- 4 CNA Angle Needle Valve (Closing)

OPTIONAL FEATURES

- A X46A Flow Clean Strainer
- B CK2 (Isolation Valve)
- D Check Valves with Isolation Valve
- F Independent Operating Pressure
- H Atmospheric Drain
- P X141 Pressure Gauge
- S CNA Angle Needle Valve (Opening)
- V X101 Valve Y X43Y Strainer

SOLENOID WIRING

Wiring must comply with local and National Electrical Codes. For valves equipped with an explosion-proof, watertight solenoid enclosure, the electrical fittings must be approved for use in the approved hazardous locations. Housings for all solenoids have connections for 1/2 inch conduit. The enclosure may be rotated to facilitate wiring.

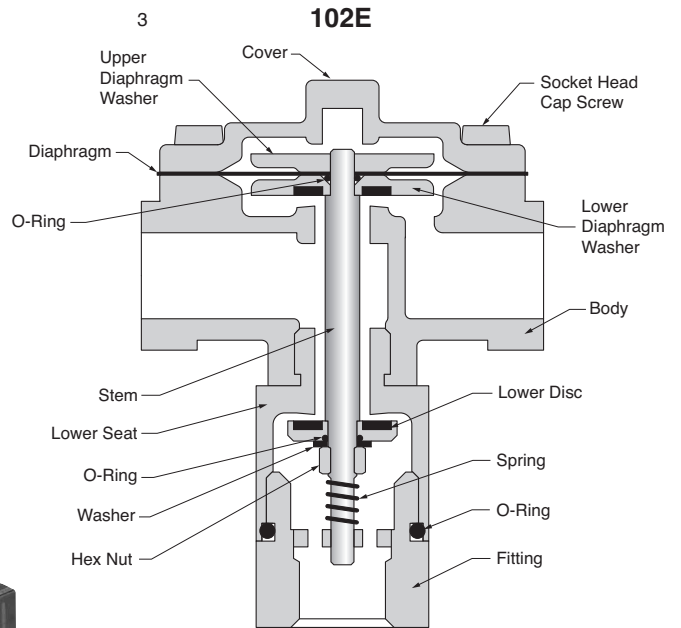

1 HYTROL MAIN VALVE

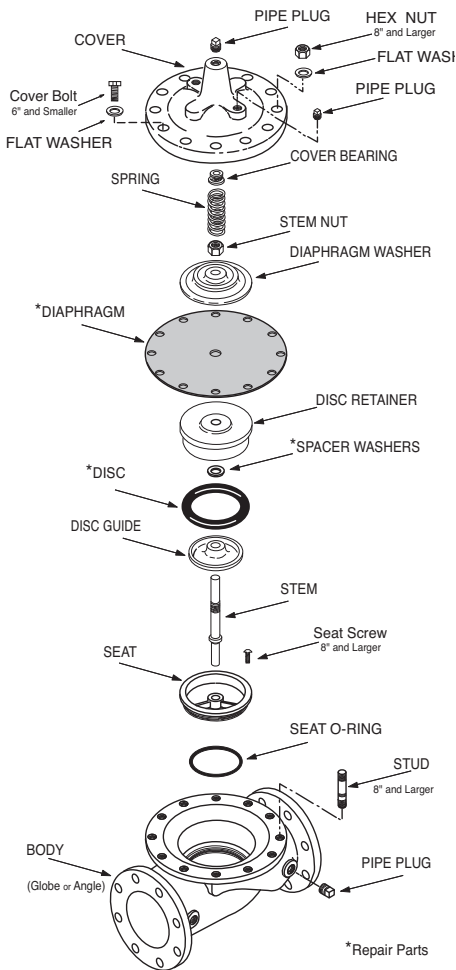

CS3
2
Manual Operator (Optional)



CNA
4



CK2
B



CDC-1
D



102E
3



X46A
A



CV
C



X43
Y

*SUGGESTED REPAIR PARTS

For a more detailed IOM Manual go to www.cla-val.com or contact a Cla-Val Regional Sales Office.