



— MODEL — **CRD18**

Pressure Reducing Control Valve For High Pressure Applications



- Direct Acting
- Hydraulic or Pneumatic Operation
- Simplified Design, Easy Adjustments
- Operates in Any Position
- Gauge Connection Port

The Cla-Val Model CRD18 Pressure Reducing Control automatically reduces a higher inlet pressure to a lower outlet pressure. It is a direct acting, spring loaded, diaphragm type control regulator that operates hydraulically or pneumatically. This valve is held open by the force of the compression spring above the diaphragm, and closes when the downstream pressure acting on the underside of the diaphragm exceeds the spring setting. The CRD18 senses downstream pressure directly.

Flow through the control responds to changes in downstream pressure. Turning the adjusting screw clockwise increases the delivery pressure, and turning it counterclockwise decreases the pressure. A resilient disc assures tight shut-off on dead-end service.

The Model CRD18 may be installed in any position. There is one inlet port and two outlets for either straight or angle installation. The second outlet port can be used for a gauge connection.

This valve is ideal as a small capacity regulator or a pilot control on a Cla-Val Automatic Control Valve.

Specifications

Size: 3/8" NPT Threaded

Materials:

Body & Cover: UNS C87850 Low Lead Bronze

Trim: Brass & Stainless Steel 303

Diaphragm and Seals: Buna-N® Rubber

Optional Materials: Consult Factory

Temperature Range: Water to 180°F Max.

Pressure Rating: 650 psi Max. Inlet

Adjustment Range: 150 to 600 psi

CRD18

1. Screw, Cap Socket Head
2. Cap
3. Screw, Adjusting
4. Nut, Hex
5. Cover
6. Spring Guide
7. Spring
8. Diaphragm Washer
9. Diaphragm
10. Yoke
11. Body and Seat Assembly
12. Gasket
13. Plug (Body)
14. Disc Retainer Assembly
15. Screw, Drive
16. Nameplate
17. Plug, Pipe
18. Ball

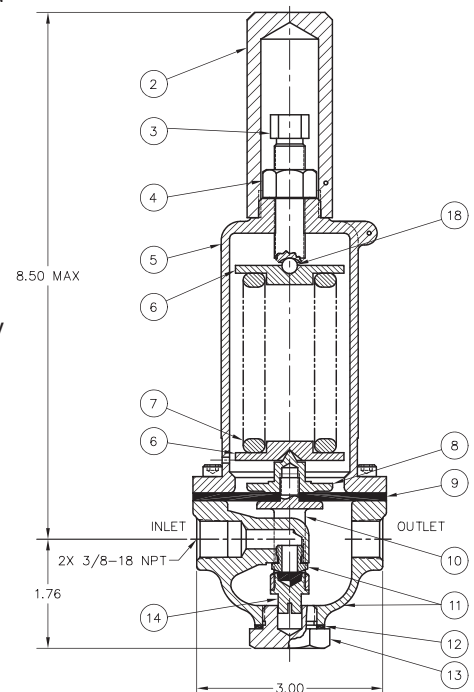
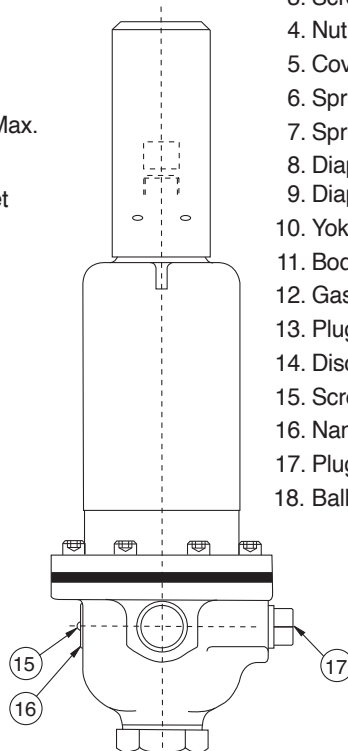
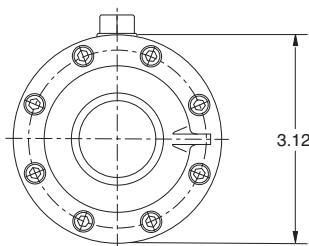

When Ordering, Please Specify

1. Catalog No. CRD18
2. Materials Desired