

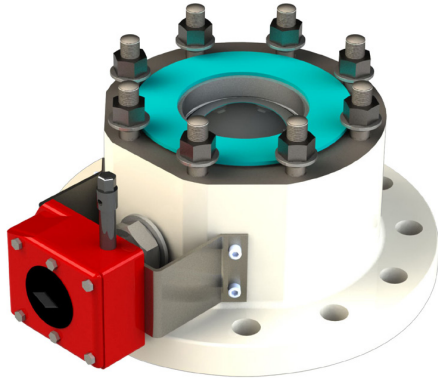

CLA-VAL 355GF/355GF-4 Hydrant Isolation Valve



- 6-inch inlet x 4-inch outlet, Mates to ANSI Flanges
- Stainless Steel “Full-Bore” Ball Valve
- Allows for complete removal of pit valve while hydrant system is in operation
- Fire Safe Qualified to API 607
- Inlet Stone Guard protects Hydrant Pit Valve
- Simple Close / Open Position Indicator
- Epoxy Coated Ductile Iron Body

The Cla-Val Model 355GF Hydrant Isolation Valve is designed to fit underneath a hydrant pit valve. Once closed, the entire Hydrant Pit Valve can be removed for maintenance or replacement while the rest of the hydrant system remains pressurized and operational.

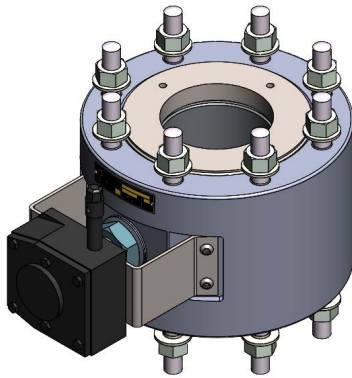

The 355GF Hydrant Isolation Valve has a 6-inch 300-pound rated inlet flange and a 4-inch 150-pound ANSI outlet flange. There is a stone guard installed at the inlet of the isolation valve that protects the isolation valve and hydrant pit valve. The overall height of 6-inches easily replaces existing non-isolating adapter spools. For new installations, specify the 355GF Hydrant Isolation Valve along with the Cla-Val 352GF Hydrant Pit Valve to achieve the standard assembly height requirement of 18-inches.

The 355GF Hydrant Isolation Valve has a stainless steel ball valve and an epoxy coated ductile iron body. The ball valve is operated by a removable T-Bar tool from the top of the pit box.

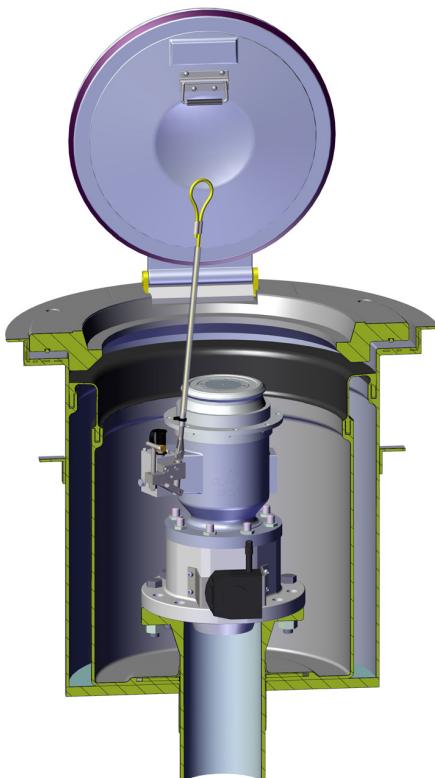

Materials Specification

Body Material	Ductile Iron ASTM A536 65-45-12
Ball	316 Stainless Steel
Ball Retainer	316 Stainless Steel
Stem	316 Stainless Steel
Strainer	303 Stainless Steel
Seals	Teflon & Buna-N
Corrosion Protection	Epoxy Coated to MIL-C-4456



CLA-VAL 355GF/355GF-4 Hydrant Isolation Valve

Dimensions (inches)

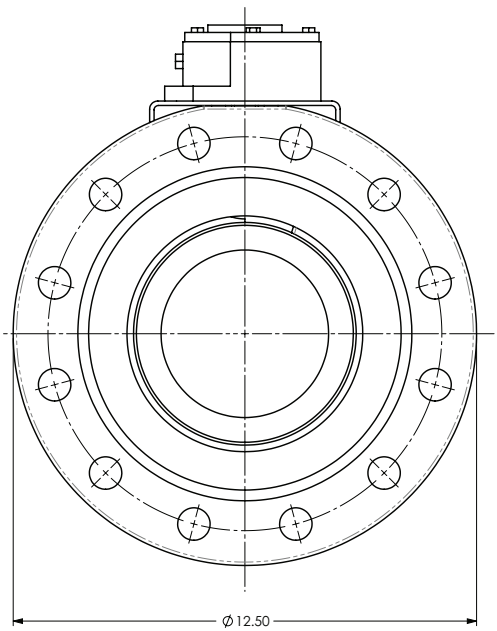
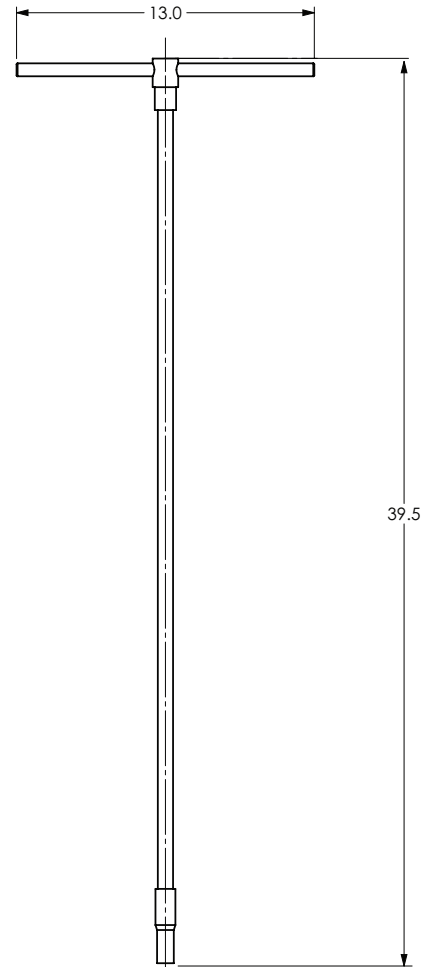
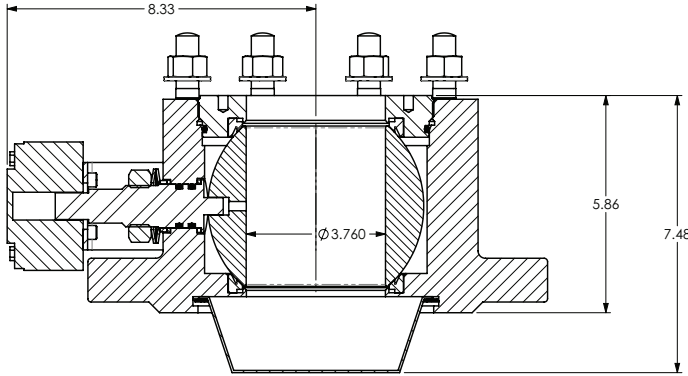

**CLA-VAL
GLOBAL HEADQUARTERS**
1701 Placentia Avenue
Costa Mesa, CA 92627
Phone: 800-942-6326
Fax: 949-548-5441
E-mail: info@cla-val.com

CLA-VAL EUROPE
Chemin des Mésanges 1
CH-1032 Romanel/
Lausanne, Switzerland
Phone: 41-21-643-15-55
Fax: 41-21-643-15-50
E-mail: cla-val@cla-val.ch

CLA-VAL FRANCE
Porte du Grand Lyon 1
ZAC du Champ du Périer
France - 01700 Neyron
Phone: 33-4-72-25-92-93
Fax: 33-4-72-25-04-17
E-mail: cla-val@cla-val.fr

CLA-VAL PACIFIC
45 Kennaway Road
Woolston, Christchurch, 8023
New Zealand
Phone: 64-39644860
www.cla-valpacific.com
E-mail: info@cla-valpacific.com