



# PINCH VALVES

**INSTALLATION**

**OPERATION**

**MAINTENANCE  
INSTRUCTIONS**

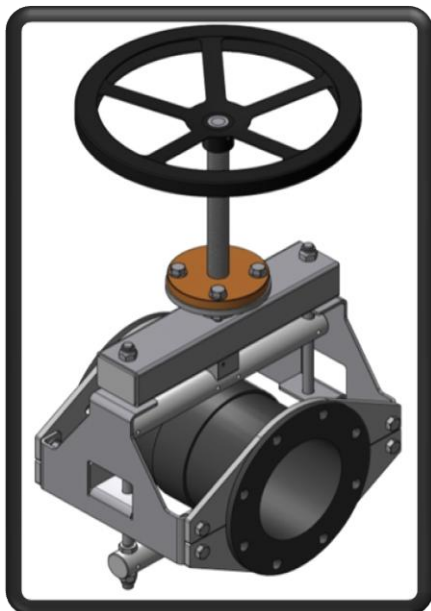

---

## SERVICE CONDITIONS

Ensure that the pinch valve ratings for temperature, pressure, and the selection of elastomeric materials match the system requirements. Please contact us if the system requirements exceed those of the pinch valve selected.

## INSTALLATION

1. **Ensure that pipe lines are depressurized before installing, removing, or servicing a pinch valve.**
2. **For automated pinch valves, ensure that all methods of activation are deactivated and secured prior to performing any maintenance.**
3. Pinch Valves come standard with 125/150# flat-faced flanges. Other flange standards are available. Consult factory for further information.
4. For best performance, a flat-faced serrated flange should be mated to the pinch valve flange face. Smooth-faced flanges may not seal properly and raised-faced flanges may damage the rubber flange.
5. Occasionally, the sleeve may be longer than the housing. To install the valve in the line, turn the hand wheel clockwise (manual valves) or stroke the actuator (automated valves) to pre-pinch the sleeve slightly. This will tighten the sleeve flanges against the body flange plates. After installing the valve in the line, return the valve to the fully open position.
6. For enclosed bodies with threaded connections, please review the bolt torque requirements at the end of this document.
7. Most pinch valves close on the centerline. This means that the yoke assembly and the lower pinch bar will rise as the valve closes. Ensure that there is sufficient space so that this movement is not restricted. Whenever possible, allow room on all sides of the valve for maintenance of components.
8. Installation in a horizontal pipeline with hand wheel or actuator at the top or at the bottom is the preferred and recommended orientation. The valve may be mounted with the hand wheel or actuator to the side of the valve (e.g. vertical installation) although, in dirty environments, this may cause wear on the valve stem and/or guide rods. For larger valves, installation in a vertical pipeline may require additional support for the valve.

## PIPE SUPPORT

Piping must be supported so that pinch valves do not carry any pipe weight.

## OPERATION

Manual, hand-wheel operated Series PV-10, PV-15, and PV-20 Pinch Valves are supplied with full port, smooth bore rubber sleeves as standard\*. The valve is operated with a hand wheel assembly linked to a pinch mechanism. This allows for manual control of abrasive and corrosive slurries (liquids and solids), even at high pressures. To close the valve, turn the hand-wheel clockwise. Turning counter-clockwise will open the valve. PV-30 Pinch Valves are supplied with full port, smooth bore rubber sleeves as standard. The valve is operated with air or water introduced into the annular cavity to pinch the sleeve and close the valve.

*\* Sleeves are also available with reduced ports for throttling and double wall for severe applications. They can be manufactured using various natural and synthetic elastomers chosen for the specific application. Consult factory for details.*

---

---

## MAINTENANCE

- A preventative maintenance schedule should be established. Site conditions and application details will help to dictate the frequency.
- Perform regular inspections and look for signs of wear.
- Ensure that all moving parts are free of debris and kept lubricated on a regular basis.
- A replacement sleeve should be available in stock to minimize downtime.

## SLEEVE REPLACEMENT

- To replace a sleeve, the entire valve must be removed from the line.

### *Open Frame Valves*

1. Remove the bolts from the positive opening tabs.
2. Unfasten the lower hex and hex jam nuts on the tie rod, and remove the lower pinch bar.
3. Remove the bolts on the end flange plates.
4. Remove at least half of the end flange plates and remove the sleeve.
5. Install the new sleeve and follow the above steps in reverse. Ensure that the bolt head on positive opening tabs is on the upstream side of the valve.
6. Grease fittings (where applicable) are located on the bearing block and the yoke plate for periodic lubrication of the valve stem. Ensure that there is a liberal application of grease to prevent seizing.

### *Closed Body Valves*

#### *PV-20*

1. Remove the bolts from the casting and remove a half.
  2. Remove the yoke, pinch elements, and stem assembly (including the hand wheel if it is convenient).
  3. Remove the hollow spring pins and then remove the lower pinch element.
  4. Remove the old sleeve.
  5. Install a new sleeve and follow the above steps in reverse.
  6. Silicone gasket the mating surfaces of the two casting halves.
-

## Recommended Bolt Torques

The information in Figure 1 can be used to select the proper bolt torque for the size of valve being installed. Ensure that all flange bolts are tightened in a criss-cross pattern, as shown in Figure 2. Start by tightening the bolts to approximately half of their recommended torque value. If further tightening is required, increase torque values in increments of 50%.

VALVE SIZE	NUMBER OF BOLTS	BOLT CIRCLE DIAMETER	THREAD SIZE	BOLT TORQUE (ft-lbs)
1"	4	3-1/8"	1/2" – 13 NC	20
1-1/2"	4	3-7/8"	1/2" – 13 NC	30
2"	4	4-3/4"	5/8" – 11 NC	50
2-1/2"	4	5-1/2"	5/8" – 11 NC	60
3"	4	6"	5/8" – 11 NC	70
4"	8	7-1/2"	5/8" – 11 NC	50
5"	8	8-1/2"	3/4" – 10 NC	60
6"	8	9-1/2"	3/4" – 10 NC	80
8"	8	11-3/4"	3/4" – 10 NC	90
10"	12	14-1/4"	7/8" – 9 NC	70
12"	12	17"	7/8" – 9 NC	100
14"	12	18-3/4"	1" – 8 NC	100
16"	16	21-1/4"	1" – 8 NC	70
18"	16	22-3/4"	1-1/8" – 7 NC	90
20"	20	25"	1-1/8" – 7 NC	90
24"	20	29-1/2"	1-1/4" – 7 NC	110
30"	28	36"	1-1/4" – 7 NC	110
36"	32	42-3/4"	1-1/2" – 6 NC	150

Figure 1

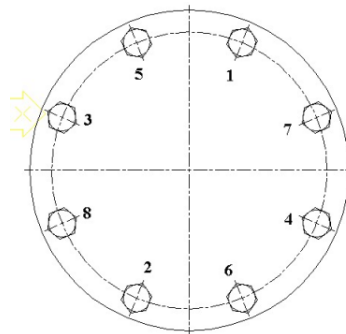

Figure 2

## WARRANTY

All products manufactured by are guaranteed against defects resulting from faulty workmanship or materials for one (1) year from date of shipment to Buyer. If any such product is found to be defective by reason of faulty workmanship or materials, then upon written notice and return of the product, and at Cla-Val's sole discretion, the defective product will be replaced or repaired by us free of charge at our factory. Claims for labor costs and other expenses required to replace and/or transport such defective product or to repair damage resulting from the use thereof will not be allowed. Our liability does not include consequential damages and is limited to the price paid for the defective product.

We shall not be bound by any other warranty other than the above set forth unless such warranty shall be agreed in writing by Cla-Val.

All Cla-Val literature is published in good faith and is believed to be reliable at time of print; however, due to product design changes, we reserve the right to make alterations from published materials at any time. Formal approval drawings are available to confirm individual products upon request at time of order.