

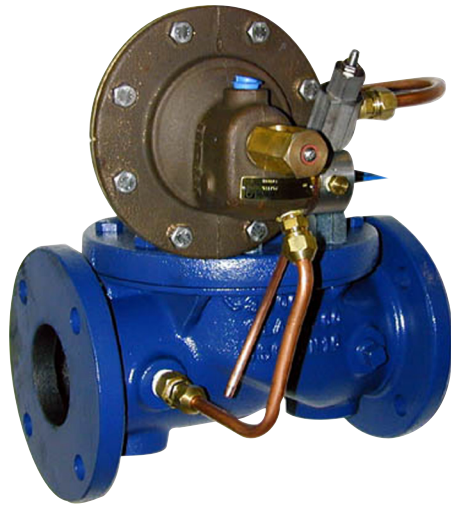

Model 20-01/620-01

(Full Internal Port) / (Reduced Internal Port)

BLENDING VALVE FOR WATER SOFTENING SYSTEMS



The Cla-Val 20-01/620-01 Blending Valve is used in systems for controlling the flow of one fluid in relation to another. It operates to maintain a pre-set percentage of one fluid to the other regardless of fluctuating demands on the blend.

The valve is a hydraulically operated, pilot controlled, diaphragm type. It is operated by line pressure and responds to commands from the pilot control. It maintains equal pressure at two sensing points, one in each line of fluid being blended. With a restriction in each line between the blending point and the sensing point, a flow rate in direct proportion to the capacities of the restrictions will be maintained. By capacity adjustment of one or both restrictions, the percentage of one fluid to the other is adjusted. For sizes 1/2", 3/4", and 1" refer to Cla-Val 20-02.

Schematic Diagram

Item	Description
1	100-01 Hytrol Main Valve
2	CDH2 Differential Control
3	CNA Needle Valve
4	X101D Position Indicator

Optional Features

Item	Description
A	X46 Flow Clean Strainer
B	CK2 Shutoff Isolation Valve
F	Omit Pilot Line To Inlet-Connects To Independent Operating Pressure
Y	X43 "Y" Strainer

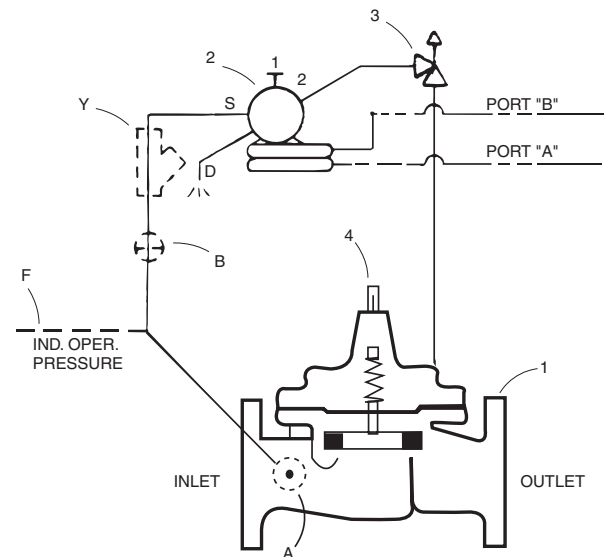

Typical Installation

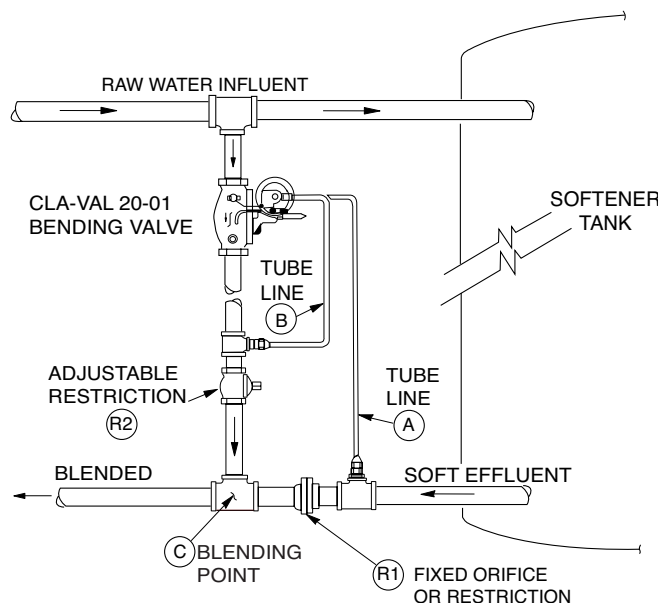

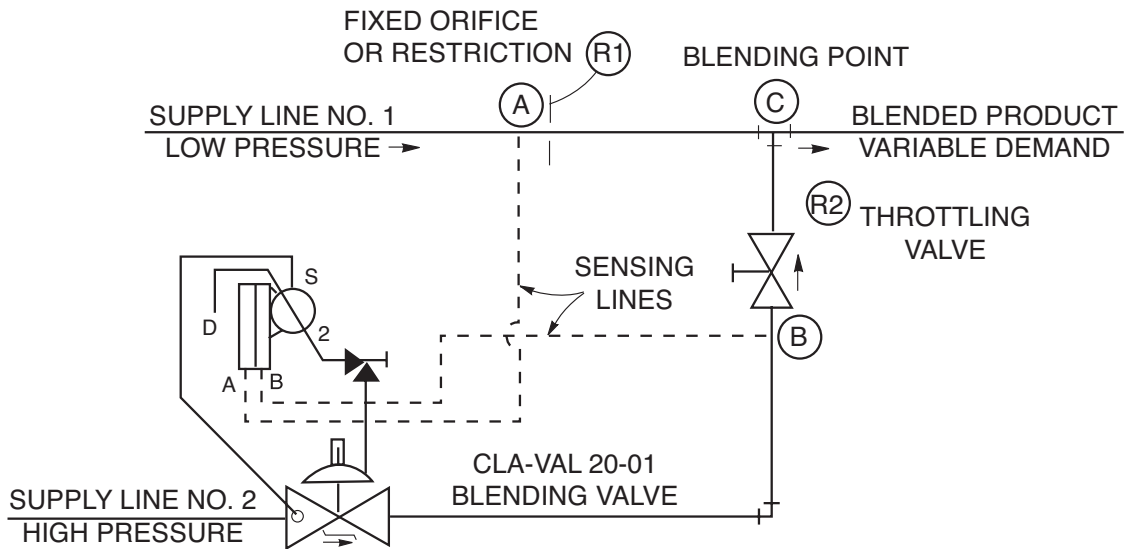

1. Pressure at B is maintained equal to pressure at A within ± 6 inches water pressure. This is accomplished by modulation of the 20-01 valve installed in the hi-pressure line.

2. With pressure at B maintained equal to pressure at A, the differential pressure between B and C will be equal to the differential pressure between A and C.

3. Flow rate through secondary restriction R2 will be maintained in relation to the flow rate through primary restriction R1. The proportional flow ratios will be directly related to the capacities of restriction R1 and R2.

4. Primary restriction at R1 can be fixed as shown, or can be adjustable the same as the secondary restriction at R2. If the primary restriction at R1 is to be fixed, it must be calibrated in relation to two things:

- A. Accuracy required at Minimum Flow Rate.
- B. Systems allowable pressure loss at Maximum Flow Rate.

For example: Excellent control will result within approximately $\pm 5\%$ accuracy when a 60" water differential is created across the fixed restriction (R1). As the flow across this restriction increases, the accuracy (in % of flow) also increases. As the flow across the restriction (R1) decreases, the accuracy (in % of flow) slightly decreases.

Therefore, where accuracy of $\pm 5\%$ or less is required over a wide flow range, at least a 60" water differential should be created across the fixed restriction (R1) at the lowest flow rate. In sizing the adjustable restriction (R2), consideration must be given to two things:

- A. Ratio of blend (flow through R2 as compared to flow through R1).
- B. Differential across R1.

To obtain a blend ratio of 1 to 1, the differential created by R2, when adjusted to "full open", must not be more than the differential created by R1 when passing an equal flow.

Where the blend ratio requires less flow at R2 than at R1, the differential created by R2 at "full open" can be proportionally more than the differential created by R1 at an equal flow rate.

Where the blend ratio requires more flow at R2 than at R1, the differential created by R2 at "full open" must be proportionally less than the differential created by R1 at an equal flow rate.

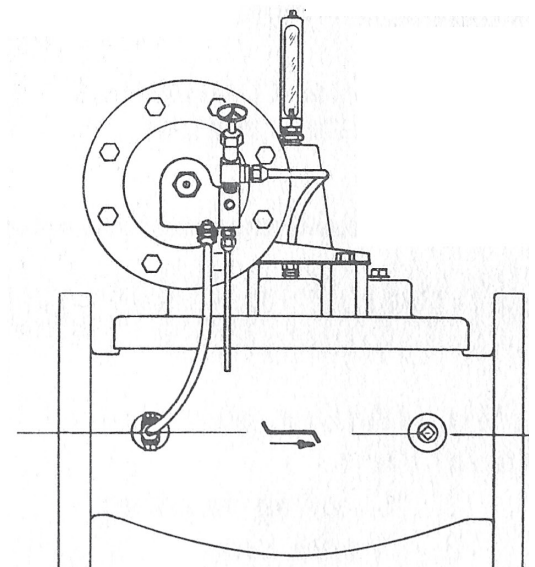
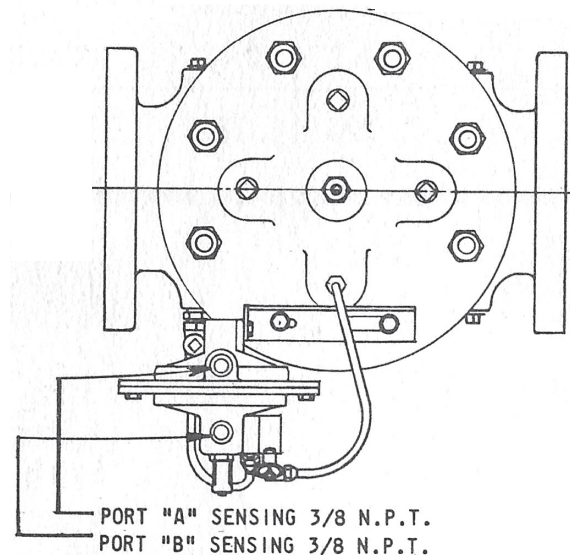

Pressure Ratings (Recommended Maximum Pressure -psi)

Valve Body & Cover		Pressure Class				
		Flanged		Grooved	Threaded	
Grade	Material	ANSI Standards*	150 Class	300 Class	300 Class	End‡ Details
ASTM A536	Ductile Iron	B16.42	250	400	400	400
ASTM A216-WCB	Cast Steel	B16.5	285	400	400	400
UNS 87850	Bronze	B16.24	225	400	400	400

Note: *ANSI standards are for flange dimensions only.
 Flanged valves are available faced but not drilled.
 ‡End Details machined to ANSI B2.1 specifications.
Valves for higher pressure are available; consult factory for details

Materials

Component	Standard Material Combinations		
	Ductile Iron	Cast Steel	Bronze
Body & Cover	Ductile Iron	Cast Steel	Bronze
100-01 Available Sizes	1" - 8"	1" - 8"	1" - 8"
100-20 Available Sizes	3" - 10"	3" - 10"	3" - 10"
Disc Retainer & Diaphragm Washer	Cast Iron	Cast Steel	Bronze
Trim: Disc Guide, Seat, & Cover Bearing	Bronze is Standard Stainless Steel is Optional		
Disc	Buna-N® Rubber		
Diaphragm	Nylon Reinforced Buna-N® Rubber		
Stem, Nut, & Spring	Stainless Steel		

For material options not listed, consult factory.
 Cla-Val manufactures valves in more than 50 different alloys.

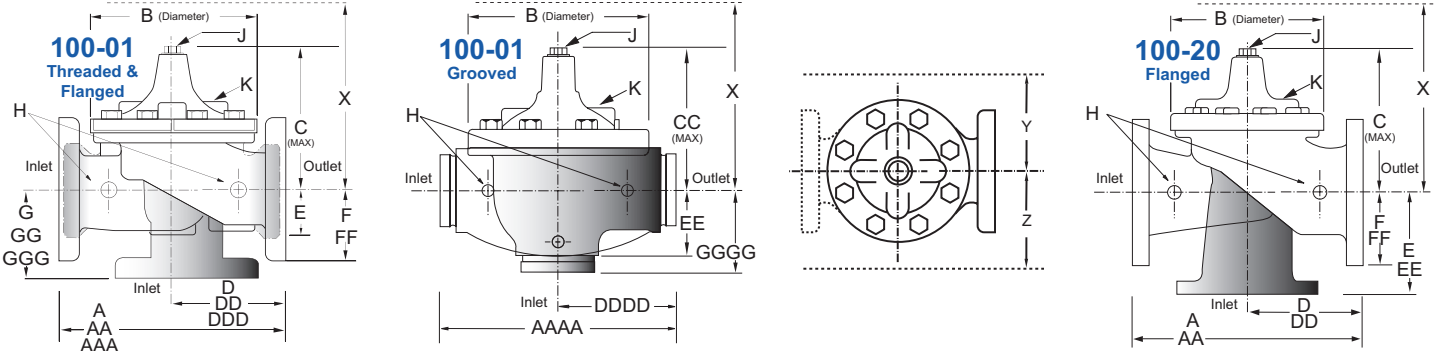

Model 100-01 Dimensions (Full Internal Port in inches)

Valve Size (Inches)	1	1 1/4	1 1/2	2	2 1/2	3	4	6	8
A Threaded	7.25	7.25	7.25	9.38	11.00	12.50	-	-	-
AA 150 ANSI	-	-	8.50	9.38	11.00	12.00	15.00	20.00	25.38
AAA 300 ANSI	-	-	9.00	10.00	11.62	13.25	15.62	21.00	26.38
AAAA Grooved End	-	-	8.50	9.00	11.00	12.50	15.00	20.00	25.38
B Dia.	5.62	5.62	5.62	6.62	8.00	9.12	11.50	15.75	20.00
C Max.	5.50	5.50	5.50	6.50	7.56	8.19	10.62	13.38	16.00
CC Max. Grooved End	-	-	4.75	5.75	6.88	7.25	9.31	12.12	14.62
D Threaded	3.25	3.25	3.25	4.75	5.50	6.25	-	-	-
DD 150 ANSI	-	-	4.00	4.75	5.50	6.00	7.50	10.00	12.69
DDD 300 ANSI	-	-	4.25	5.00	5.88	6.38	7.88	10.50	13.25
DDDD Grooved End	-	-	-	4.75	-	6.00	7.50	-	-
E	1.12	1.12	1.12	1.50	1.69	2.06	3.19	4.31	5.31
EE Grooved End	-	-	2.00	2.50	2.88	3.12	4.25	6.00	7.56
F 150 ANSI	-	-	2.50	3.00	3.50	3.75	4.50	5.50	6.75
FF 300 ANSI	-	-	3.06	3.25	3.75	4.13	5.00	6.25	7.50
G Threaded	-	1.88	1.88	3.25	4.00	4.50	-	-	-
GG 150 ANSI	-	-	4.00	3.25	4.00	4.00	5.00	6.00	8.00
GGG 300 ANSI	-	-	4.25	3.50	4.31	4.38	5.31	6.50	8.50
GGGG Grooved End	-	-	-	3.25	-	4.25	5.00	-	-
H NPT Body Tapping	.375	.375	.375	.375	.50	.50	.75	.75	1
J NPT Cover Center Plug	.25	.25	.25	.50	.50	.50	.75	.75	1
K NPT Cover Tapping	.375	.375	.375	.375	.50	.50	.75	.75	1
Stem Travel	0.4	0.4	0.4	0.6	0.7	0.8	1.1	1.7	2.3
Approx. Ship Wt. Lbs.	15	15	30	50	65	85	160	300	520
X Pilot System	11	11	11	13	14	15	17	29	31
Y Pilot System	9	9	9	9	10	11	12	20	22
Z Pilot System	9	9	9	9	10	11	12	20	22

Model 100-20 Dimensions (Reduced Internal Port in inches)

Valve Size (Inches)	3	4	6	8	10
A 150 ANSI	10.25	13.88	17.75	21.38	26.00
AA 300 ANSI	11.00	14.50	18.62	22.38	27.38
B Dia.	6.62	9.12	11.50	15.75	20.00
C Max.	7.00	8.62	11.62	15.00	17.88
D 150 ANSI	-	6.94	8.88	10.69	Consult Factory
DD 300 ANSI	-	7.25	9.38	11.19	Consult Factory
E 150 ANSI	-	5.50	6.75	7.25	Consult Factory
EE 300 ANSI	-	5.81	7.25	7.75	Consult Factory
F 150 ANSI	3.75	4.50	5.50	6.75	8.00
FF 300 ANSI	4.12	5.00	6.25	7.50	8.75
H NPT Body Tapping	.375	.50	.75	.75	1
J NPT Cover Center Plug	.50	.50	.75	.75	1
K NPT Cover Tapping	.375	.50	.75	.75	1
Stem Travel	0.6	0.8	1.1	1.7	2.3
Approx. Ship Wt. Lbs.	85	160	300	520	645
X Pilot System	13	15	27	30	33
Y Pilot System	10	11	18	20	22
Z Pilot System	10	11	18	20	22

20-01 Valve Selection	100-01 Pattern: Globe (G), Angle (A), End Connections: Threaded (T), Grooved (GR), Flanged (F) Indicate Available Sizes									
	Inches	1	1 ¹ / ₄	1 ¹ / ₂	2	2 ¹ / ₂	3	4	6	8
	mm	25	32	40	50	65	80	100	150	200
Basic Valve 100-01	Pattern	G, A	G, A	G, A	G, A	G, A	G, A	G, A	G, A	G, A
	End Detail	T	T	T, F, Gr*	T, F, Gr	T, F, Gr*	T, F, Gr	F, Gr	F, Gr*	F, Gr*
Suggested Flow (gpm)	Maximum	55	55	75	120	180	270	480	1100	1900
	Minimum	1	1	1	1	2	2	4	10	15
Suggested Flow (Liters/Sec)	Maximum	3.5	3.5	5	8	11	17	30	69	120
	Minimum	.03	.03	.03	.06	.09	0.13	0.25	0.63	0.95

100-01 Series is the full internal port Hytrol. For Lower Flows Consult Factory *Globe Grooved Only

620-01 Valve Selection	100-20 Pattern: Globe (G), Angle (A), End Connections: Flanged (F) Indicate Available Sizes					
	Inches	3	4	6	8	10
	mm	80	100	150	200	250
Basic Valve 100-20	Pattern	G	G, A	G, A	G, A	G
	End Detail	F	F	F	F	F
Suggested Flow (gpm)	Maximum	120	270	480	1100	1900
	Minimum	1	2	4	10	15
Suggested Flow (Liters/Sec)	Maximum	8	17	30	69	120
	Minimum	.06	.13	.25	.63	.95

100-20 Series is the reduced internal port size version of the 100-01 Series. For Lower Flows Consult Factory

Valve Specifications

End Details

1-1/4" - 3" Threaded
1-1/2" - 8" Flanged

Temperature Range:

Water: to 180° F. Max.

Pressure Ratings

125 Class and 250 ANSI B16.1
125 Class - 175 psi Max.
250 Class - 300 psi Max.

Purchase Specifications

The blending valve shall be a pilot controlled hydraulically operated diaphragm type globe valve with single seated composition disc. It shall be operated by line pressure and respond to commands from the pilot control. In a blending system, the valve shall operate to maintain the flow rate of one fluid in direct proportion to the flow rate of another fluid. It shall maintain the same percent of one fluid to the other in the blend regardless of variable system inlet pressures or variable demands on the blend. It shall automatically adjust the percent of one of the fluids in the blend, in response to any setting of an adjustable restriction in the line being proportioned.

Pilot System Specifications

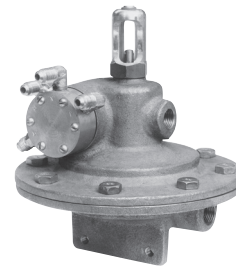

CDH2 Differential Control

Materials

Standard Pilot System Materials
Pilot Control: Low Lead Bronze
Trim: Stainless Steel Type 303 and Monel

Optional Pilot System Materials

Pilot Systems are available with optional Cast Steel, Bronze, Aluminum

When Ordering, Please Specify

1. Catalog No. 20-01 or No. 620-01
2. Valve Size
3. Pattern - Globe or Angle
4. Pressure Class
5. Threaded or Flanged
6. Trim Material
7. Desired Options
8. When Vertically Installed

