



Model CRD-L DIRECT ACTING PRESSURE REDUCING VALVE



- Sizes: 1/2", 3/4", 1", 1 1/4", 1 1/2", 2", 2 1/2"
- Operates in Any Position
- Easy Installation
- Stainless Steel Trim Standard
- Gauge Connections Standard
- All Bronze Body and Cover
- Meets Requirements of "Reduction of Lead in Drinking Water Act"

The Cla-Val Model CRD-L Pressure Reducing Valve automatically reduces a higher inlet pressure to a steady lower downstream pressure with our unique design. This valve is an accurate regulator capable of holding downstream pressure to a predetermined amount, regardless of upstream pressure fluctuations.

Periodic maintenance consist of regular internal cleaning that is accessed by removing bottom plug.

Typical Applications

High rise buildings use Model CRD-L Pressure Reducing Valves in various water systems (potable water, boiler feed air conditioning, etc.) to control pressure fluctuations between floors.

Industrial plants use Model CRD-L Pressure Reducing Valves between a high pressure supply system and equipment requiring lower pressure. Typically Model CRD-L Pressure Reducing Valves are used at supply connections for water heaters, boiler feed water or other process water systems.

Municipal water systems use Model CRD-L Pressure Reducing Valves at service connections in a high pressure distribution zone. Depending on flow requirements, Model CRD-Ls may be installed in parallel.

One Model CRD-L provides desired outlet pressure while the second Model CRD-L handles low flow conditions. If necessary, additional Model CRD-Ls can be added for more flow capacity. The Model CRD-L is also ideal for a low flow bypass around a larger Cla-Val 90 Series Pressure Reducing Valve.

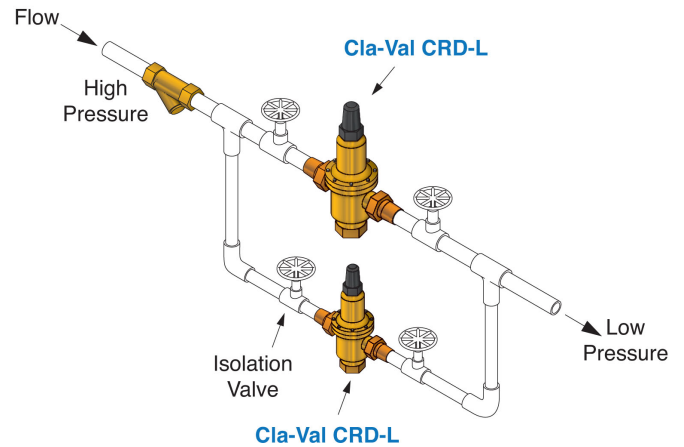
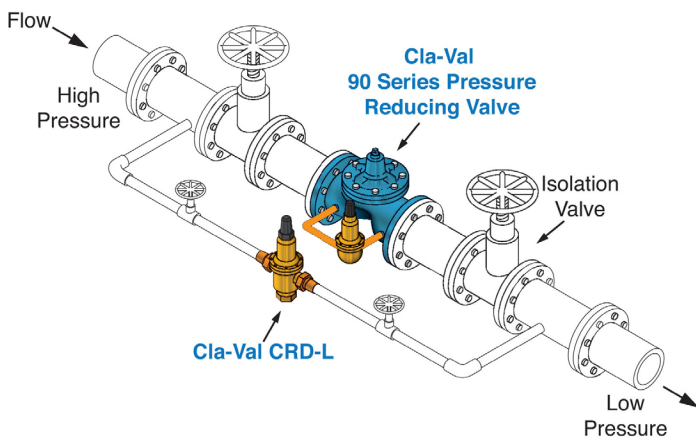

Valve Operation

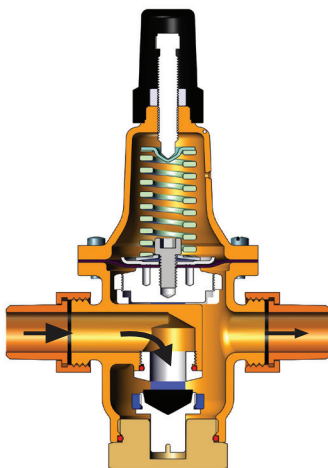

Flow Condition

When flow begins, the pressure on the underside of the diaphragm will be lower than the set-point of the spring causing the diaphragm to move the valve seat away from the valve seal allowing flow to occur. As the flow increases downstream, the pressure acting on the spring pushes the diaphragm and the valve seat away from the valve seal to regulate outlet pressure to desired value.

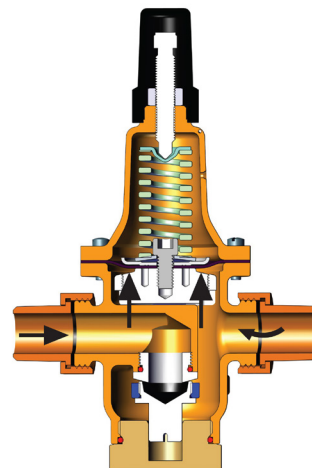

No Flow Condition

When there is no flow, the downstream pressure increases and acts against the under side of the diaphragm, pulling the valve seat up against the valve seal to close the valve.

Reduced Pressure Falloff

Unlike pilot controlled pressure reducing valves, direct acting valves are subject to "reduced pressure falloff" (RPF). Reduced pressure falloff is the decrease in downstream regulated pressure that occurs when the flow increases. When the demand for flow increases, the valve must open wider and wider to permit the flow. The only way the valve can open is for the spring force to be greater than the hydraulic force under the diaphragm (the force trying to close the valve). The downstream pressure therefore, must "fall off" or decrease before the spring can open the valve. All spring actuated direct acting valves have similar operating characteristics.

Noise and Velocity Guidelines

Noise in water piping systems can sometimes be attributed to high velocities of water through the valve seat. In general, as the water velocity increases, the noise produced by the installation will increase. Where noise levels are important, such as residences, hospitals, or schools, pipeline velocities should be in the range of 5 to 10 fps. The chart below shows velocity and the corresponding reduced pressure falloff.

Velocity Guide Chart

Velocity Delta from Set Point, fps	Set Point Pressure Falloff psi			
	1/2, 3/4" and 1"	1-1/4" and 1-1/2"	2"	2-1/2"
5.0	6.0	3.5	15	27
7.5	9.5	6.5	17	34
10.0	12.5	8.5	22	40

Sizing

Step One

Determine the following from the application:

1. Inlet pressure and desired outlet pressure
2. Maximum and minimum flow rate
3. Allowable reduced pressure falloff or maximum velocity based on acceptable noise level

Step Two

Determine the pressure differential across the valve by subtracting the desired outlet pressure from the inlet pressure. If there will be any fluctuations in the inlet pressure, calculate both high and low differentials. At all times the differential must be at least 14.5 psi. When the differential is greater than 150 psi, use two valves in series.

Step Three

Determine the valve size by using the Valve Capacity Charts on the next page. Start by referring to the valve capacity chart for the system's maximum flow rate. Locate the value for the maximum allowable reduced pressure falloff for your application. Select the valve size with a RPF value that is less than the maximum RPF.

For further assistance, contact a Cla-Val representative to utilize sizing software for system design and optimization. Cla-Val's software follows industry standard for single or parallel pressure regulators to prevent under and oversizing. Sizing software allows for wide range of flow requirements to avoid cavitation and noise.

Valve Capacity Chart

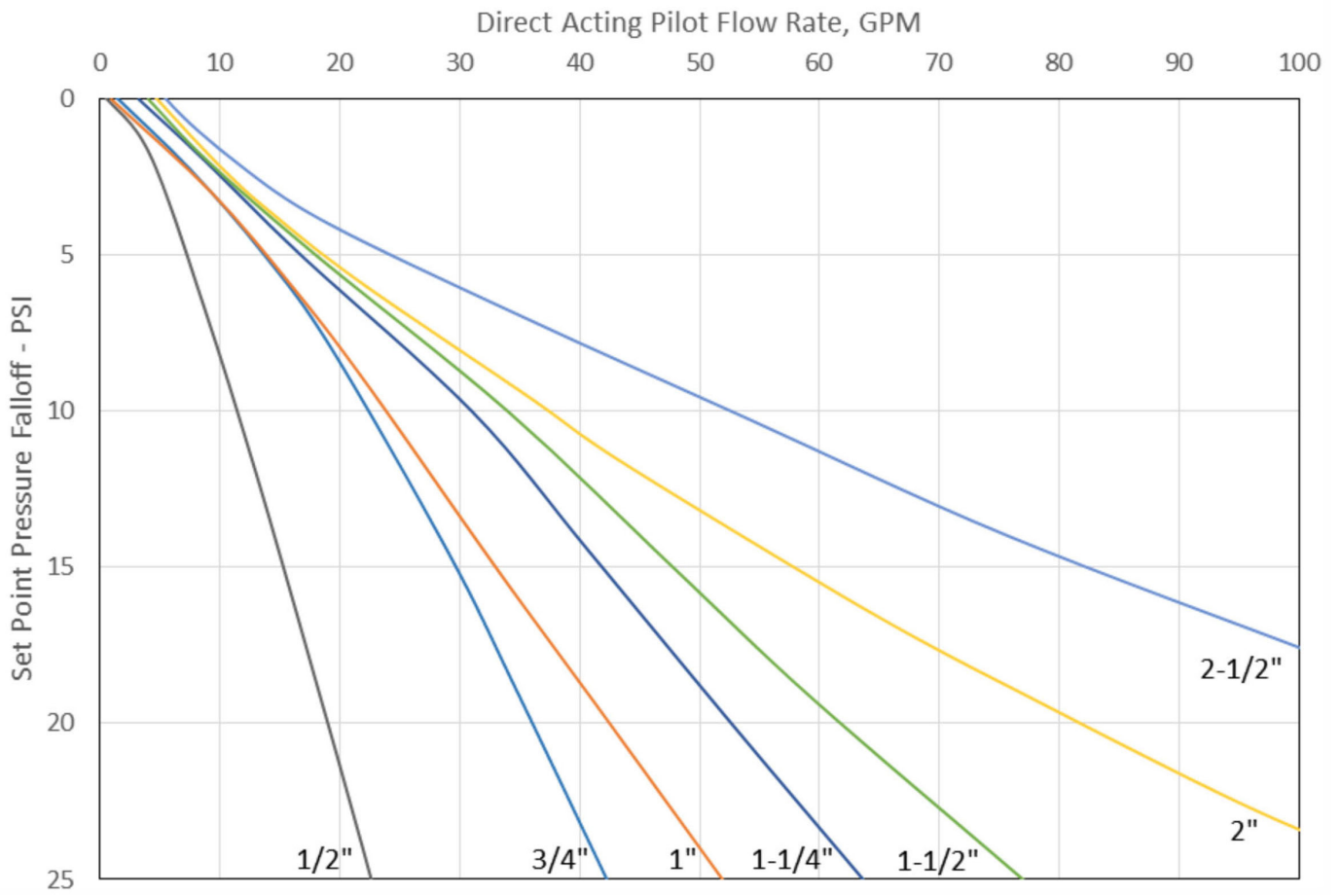

*Valve Size and Spring Adjustment Range			
1/2, 3/4" and 1"	1-1/4" and 1-1/2"	2"	2-1/2"
6.0	3.5	15	27
9.5	6.5	17	34
12.5	8.5	22	40

*Lower pressure spring ranges available, consult factory.

Specifications

Temperature

Water: to 140° F (70°C) Max

Diaphragm

Buna-N®

Disc

EPDM

Strainer

Inline Mesh

Materials

Body and Cover: Low Lead Bronze

Pressure Ratings

Maximum Inlet Pressure: 400 psi (25 Bar)

Maximum Differential Pressure: 150 psi (10 Bar)

Minimum Differential Pressure: 14.5 psi

In Inches

Dimensions

Size	A	B	C	D	E	Weight (lbs.)
1/2"	5.72	6.06	2.56	3.12	8.62	4.00
3/4"	5.60	6.06	2.56	3.12	8.62	4.00
1"	6.68	6.06	2.56	3.12	8.62	4.00
1-1/4"	8.40	7.84	2.75	4.13	10.59	7.50
1-1/2"	9.56	7.84	2.75	4.13	10.59	8.50
2"	11.37	8.11	3.06	4.91	11.17	12.50
2-1/2"	12.19	8.11	3.06	4.91	11.17	13.75

In Millimeters

Dimensions

Size	A	B	C	D	E	Weight (kgs.)
13	143	154	66	80	219	1.8
20	143	154	66	80	219	1.8
25	170	154	66	80	219	1.8
32	214	199	70	105	269	3.4
40	243	199	70	105	269	3.9
50	289	205	78	105	283	5.6
65	310	205	78	105	283	6.2

Gauge Connections

1/2" through 2 1/2" has 1/8" FNPT

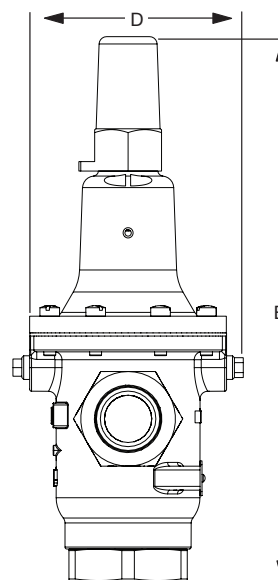
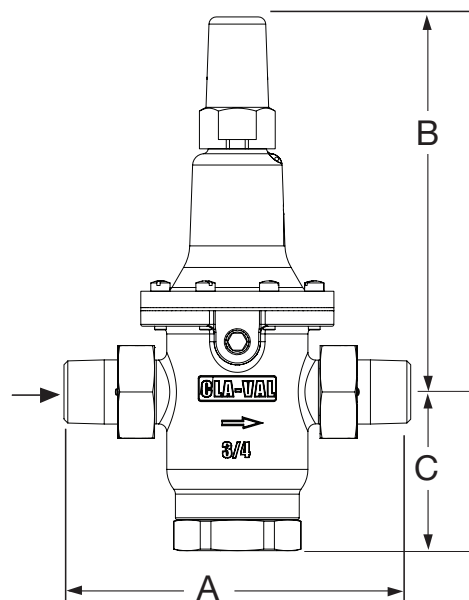

When Ordering, Please Specify

1. Catalog No. CRD-L
2. Size
3. Adjustment Range
4. Optional Locking Cap

