



# Model 60-BT PUMP CONTROL VALVE WITH HIGH CAPACITY CSM11-HC



- Built-in Check Valve
- Valve Uses Line Pressure for Operation
- Opening and Closing Rates Adjusted Separately
- Solenoid Control Can Be Operated Manually
- Can be integrated with SCADA when controlled by the PC-22D Electronic Pump Control Panel

The Cla-Val Model 60-BT Pump Control Valve is a pilot-operated valve designed for installation on the discharge of booster pumps to eliminate pipeline surges caused by the starting and stopping of the pump.

The pump starts against a closed valve. When the pump is started, the solenoid control is energized and the valve begins to open slowly, gradually increasing line pressure to full pumping head. When the pump is signaled to shut-off, the solenoid control is de-energized and the valve begins to close slowly, gradually reducing flow while the pump continues to run. When the valve is closed, a limit switch assembly, which serves as an electrical interlock between the valve and the pump, releases the pump starter and the pump stops.

Should a power failure occur, a built-in lift-type check valve closes the moment flow stops, preventing reverse flow regardless of solenoid or diaphragm assembly position.

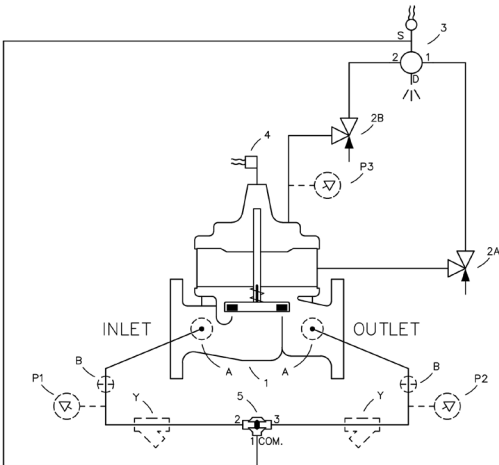

Schematic Diagram	
Item	Description
1	100-03 Powercheck Main Valve
2	CV Flow Control
3	CSM11-HC Solenoid Control
4	X105LCW Switch Assembly
5	CVS-1 Shuttle Valve

Optional Features	
Item	Description
A	X46A Flow Clean Strainer
B	CK2 (Isolation Valve)
P	X141 Pressure Gauge
Y	X43 "Y" Strainer
PC	PC-22D Pump Control Panel



See page 2 for approvals.

## Typical Applications

Install the valve as shown to help prevent pipelines surges during pump starting and stopping. Flexible conduit should be used for electrical connections to the solenoid control and the limit switch. A Cla-Val Model 52-03 Surge Anticipator Valve is recommended for power failure protection or the Model 652-03 if a reduced port valve is required. Use the PC-22D Electronic Pump Control Panel for applications where electronic control and integration with SCADA is desired.

**Note:** Installation with valve stem vertical up is recommended. For horizontal stem installation use Cla-Val Model 60-73 or, if a reduced port valve is required, Model 660-73.

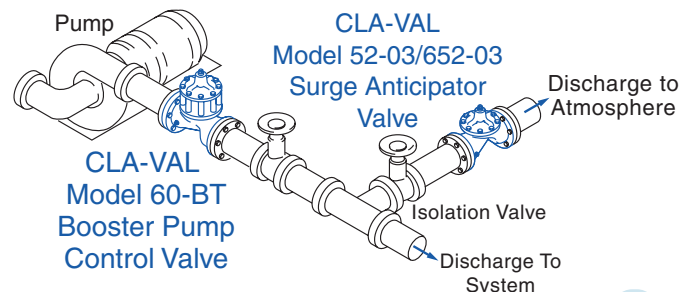

**Model 60-BT** (Uses Powercheck Main Valve 100-03)

Recommended Maximum Pressure - psi

**Pressure Ratings**

Valve Body & Cover		Pressure Class			
		Flanged			Threaded
Grade	Material	ANSI Standards*	150 Class	300 Class	End‡ Details
ASTM A536	Ductile Iron	B16.42	250	400	400
ASTM A216-WCB	Cast Steel	B16.5	285	400	400
UNS 87850	Bronze	B16.24	225	400	400

**Note:**  
 \* ANSI standards are for flange dimensions only. Flanged valves are available faced but not drilled.  
 ‡ End Details machined to ANSI B2.1 specifications.  
 Valves for higher pressure are available; consult factory for details

**Materials**

Component	Standard Material Combinations			
	Body & Cover	Ductile Iron	Cast Steel	Bronze
100-03 Available Sizes	10" - 16"	10" - 16"	10" - 16"	10" - 16"
Disc Retainer & Diaphragm Washer	Cast Iron	Cast Steel	Bronze	
Trim: Disc Guide, Seat & Cover Bearing	Bronze is Standard Stainless Steel is Optional			
Disc	Buna-N® Rubber			
Diaphragm	Nylon Reinforced Buna-N® Rubber			
Stem, Nut & Spring	Stainless Steel			

For material options not listed, consult factory. Cla-Val manufactures valves in more than 50 different alloys.

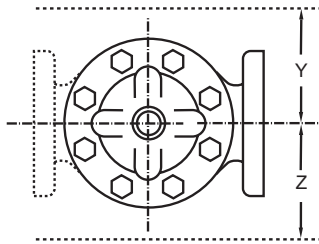
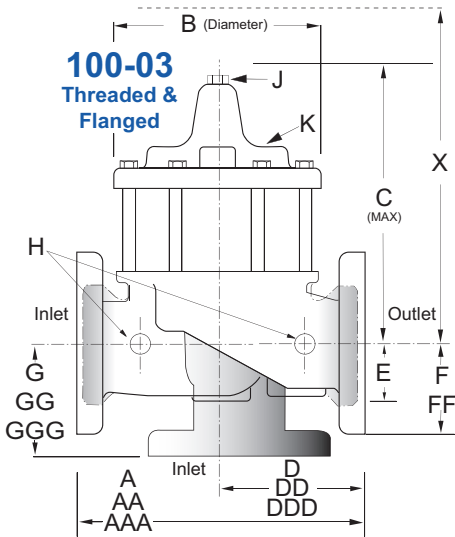

**Valve & Pilot Approvals**

NSF/ANSI 372: National Lead Free Mandate "Reduction of Lead in Drinking Water Act"

Cla-Val fulfills the requirements described in the American Water Works Association's (AWWA) Standard for Pilot-Operated Control Valves: C530:12

In Inches

**Model 60-BT Dimensions**

Valve Size (Inches)	10	12	14	16
A Threaded	—	—	—	—
AA 150 ANSI	29.75	34.00	39.00	41.38
AAA 300 ANSI	31.12	35.50	40.50	43.50
B Diameter	23.62	28.00	32.75	35.50
C Maximum	23.38	29.31	32.12	35.00
D Threaded	—	—	—	—
DD 150 ANSI	14.88	17.00	19.50	20.69
DDD 300 ANSI	15.56	17.75	20.25	21.75
E	9.25	10.75	12.62	15.50
F 150 ANSI	8.00	9.50	10.50	11.75
FF 300 ANSI	8.75	10.25	11.50	12.75
G Threaded	—	—	—	—
GG 150 ANSI	8.62	13.75	14.88	15.69
GGG 300 ANSI	9.31	14.50	15.62	16.50
H NPT Body Tapping	1.00	1.00	1.00	1.00
J NPT Cover Center Plug	1.00	1.25	1.50	2.00
K NPT Cover Tapping	1.00	1.00	1.00	1.00
Stem Travel	2.80	3.40	4.00	4.50
Approx. Ship Weight (lbs)	940	1675	2460	3100
Approx. X Pilot System	30.00	37.00	41.00	43.00
Approx. Y Pilot System	20.00	22.00	24.00	26.00
Approx. Z Pilot System	20.00	22.00	24.00	26.00

60-BT Valve Selection	100-03 Pattern: Globe (G), Angle (A), End Connections: Threaded (T), Flanged (F) Indicate Available Sizes				
	Inches	10	12	14	16
	mm	250	300	350	400
Main Valve 100-03	Pattern	G, A	G, A	G, A	G, A
	End Detail	F	F	F	F
Suggested Flow (gpm)	Maximum	4900	7000	8400	11000
	Maximum Intermittent	6150	8720	10540	13700
Suggested Flow (Liters/Sec)	Maximum	309	442	530	694
	Maximum Intermittent	387	549	664	863

**100-03 Series is the full internal port Powercheck**

### Model 60-BT (Uses Powercheck Main Valve 100-03)

Volts (AC 60 Hz)	Amperes		Coil Resistance Ohms
	Holding	Inrush	
24	2.88	25.4	0.5
120	0.575	5.1	14.1
208	0.330	2.93	40
240	0.288	2.54	58
440	0.156	1.38	174
440	0.143	1.27	233

Volts (AC 60 Hz)	Amperes		Coil Resistance Ohms
	Holding	Inrush	
110	0.48	4.6	15.7
220	0.24	2.3	66
240	0.22	2.1	88

### When Ordering, Please Specify

- Catalog No. 60-BT
- Valve Size
- Pattern - Globe or Angle
- Pressure Class
- Trim Material
- Electrical Selection
- Desired Options
- When Vertically Installed

### CSM11-HC Specifications



**Enclosure**  
General purpose NEMA Type 3; Aluminum  
**Note:** For other enclosures and NEMA Types, consult factory

**Housing**  
Body: Aluminum  
Trim: Stainless Steel

**Operating Pressure**  
Maximum pressure 300 psi, for higher pressure consult factory.

**Coil Insulation**  
Class A (molded)

**AC Voltage**  
15.4 watts

### Pilot System Specifications

**Temperature**  
Water to 180°F Max

**Materials**  
**Standard Pilot System Materials**  
Pilot Control: Low Lead Bronze  
Trim: Stainless Steel Type 303  
Rubber: Buna-N® Synthetic Rubber

**Optional Pilot System Materials**  
Pilot Systems are available with optional Aluminum, Stainless Steel or Monel materials.

### Optional Electronic Control

The Cla-Val PC-22D provides control of the pump and pump control valve, preventing surges in the system when the pump starts or stops. It consists of a pre-wired electrical control panel employing a programmable valve controller to sequence the pump and pump control valve during all modes of operation. Provides added protection to the pumping system from damage caused by mechanical, hydraulic or power failure.

The PC-22D offers all the control features found in the recommended wiring diagrams for Cla-Val pump control valves, plus alarms, automatic shutdown and adjustable timers.



## Sequence of Operation

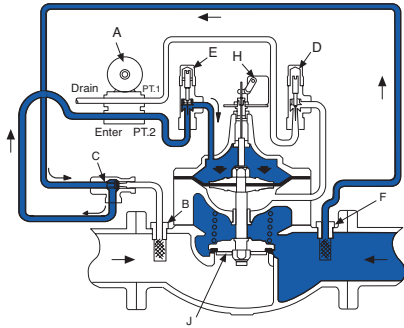

### Pump Off

With pump off, line pressure exists above the diaphragm holding the main valve closed. Shuttle valve C always supplies highest pressure to solenoid control A through strainers B and F. If power failure occurs when valve is open, the built-in check valve J closes immediately to prevent reverse flow.

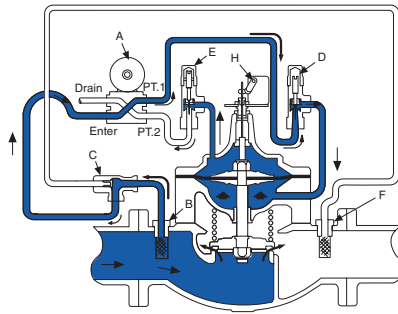

### Starting Cycle

Starting switch closes, pump starts, solenoid control energizes. Upstream fluid flows to chamber below main valve diaphragm through strainer B, shuttle valve C, solenoid control A, and closing rate flow control D. Valve opens slowly as fluid from diaphragm chamber is gradually released to atmosphere through opening rate flow control E and solenoid control A.

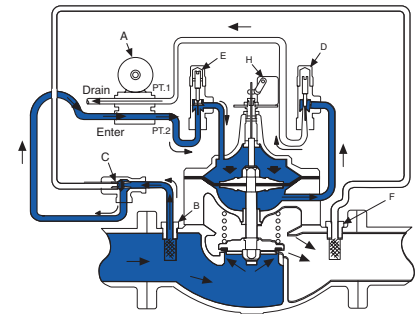

### Stopping Cycle

Starting switch opens, solenoid control de-energizes. Upstream fluid flows to valve diaphragm through strainer B, shuttle valve C, solenoid control A and opening rate Flow Control E. Valve closes slowly as fluid below diaphragm chamber is gradually released to atmosphere through closing rate flow control D and solenoid control A.

## Model 60-BT Flow Chart (Uses Powercheck Main Valve 100-03)

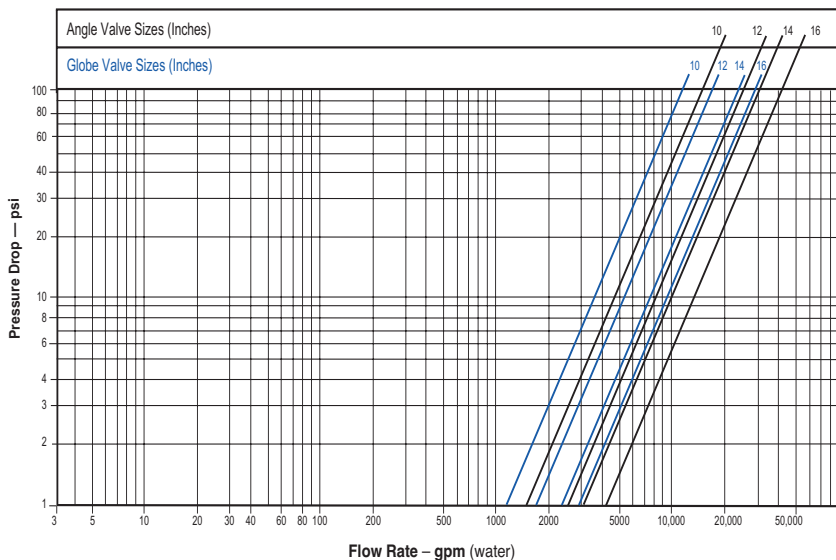

Liquid Volume Displaced from Diaphragm Chamber When Valve Opens or Closes	
Sizes (Inches)	60-BT Displacement (Gallons)
10"	2.51
12"	4.00
14"	6.50
16"	9.57

\*Consult factory if pressure is less than 10 psi

## Valve Sizing

Sizing Model 60-BT Pump Control Valves is similar to sizing non-modulating type valves. Simply select the smallest size valve that will handle the pump output at an acceptable head loss for the application.

**Do not oversize.** Oversizing a Pump Control Valve will nullify its ability to prevent surges caused by the starting and/ or stopping of the pump. Maximum flow values are given in the selection table above. Flow characteristics are shown on flow charts (over leaf) for these valve.

**Example:** A booster pump with a rated output of 700 gpm and 4 psi is an acceptable head loss for the application. The flow chart for the 100-03 (60-BT) indicates that a 8" globe valve has less than 4 psi pressure drop at 700 gpm.

### Drain Provisions

Each time the valve opens or closes, water is discharged from the solenoid exhaust port, the amount varying with the valve size. Provisions should be made for the disposal of this water. Exhaust tube must be free of any back pressure. Provide an air gap between the solenoid exhaust tube and drain facility.