

CLA-VAL

AUTOMATIC CONTROL VALVES

131-22/631-22

Place this manual with personnel responsible
for maintenance of this valve

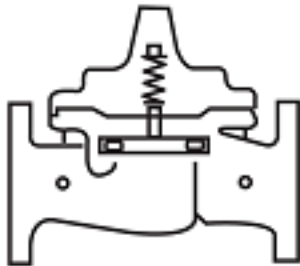

Installation



Operation

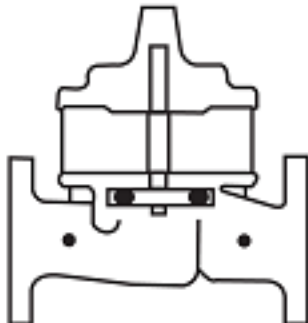

Maintenance



CLA-VAL • 1701 Placentia Avenue • Costa Mesa, CA 92627 • (949) 722-4800 • info@cla-val.com
CLA-VAL CANADA LTD. • 4687 Christie Drive • Beamsville, Ontario, LOR 1B4 Canada • (905) 563-4963

www.cla-val.com • info@cla-val.com



Recommended Inspections

Cla-Val recommends that an inspection be performed on our products annually. The inspection should include both a visual and functional test of the main valve/component and the pilot system. The inspection ensures that no damage or premature wear occurred due to velocity, pressure, or foreign matter within the fluid that may have exceeded the valve's design. Please consult the maintenance manual for specific information on the model. Manuals are available for download at Cla-Val.com, as well as contact information for a company representative.

Accurate record-keeping is a best practice for any preventative maintenance program, and Cla-Val strongly recommends this action through an asset management program. Cla-Val provides a free asset management tool, Link2Valves [Link2Valves - Cla-Val \(cla-val.com\)](http://Link2Valves - Cla-Val (cla-val.com)), to assist in preventative maintenance record-keeping and scheduling.



Model **131-22/631-22**

Electronic Interface Control Valve
(Power Fail Closed)

----- NOT FURNISHED BY CLA-VAL CO. ----- OPTIONAL FEATURES

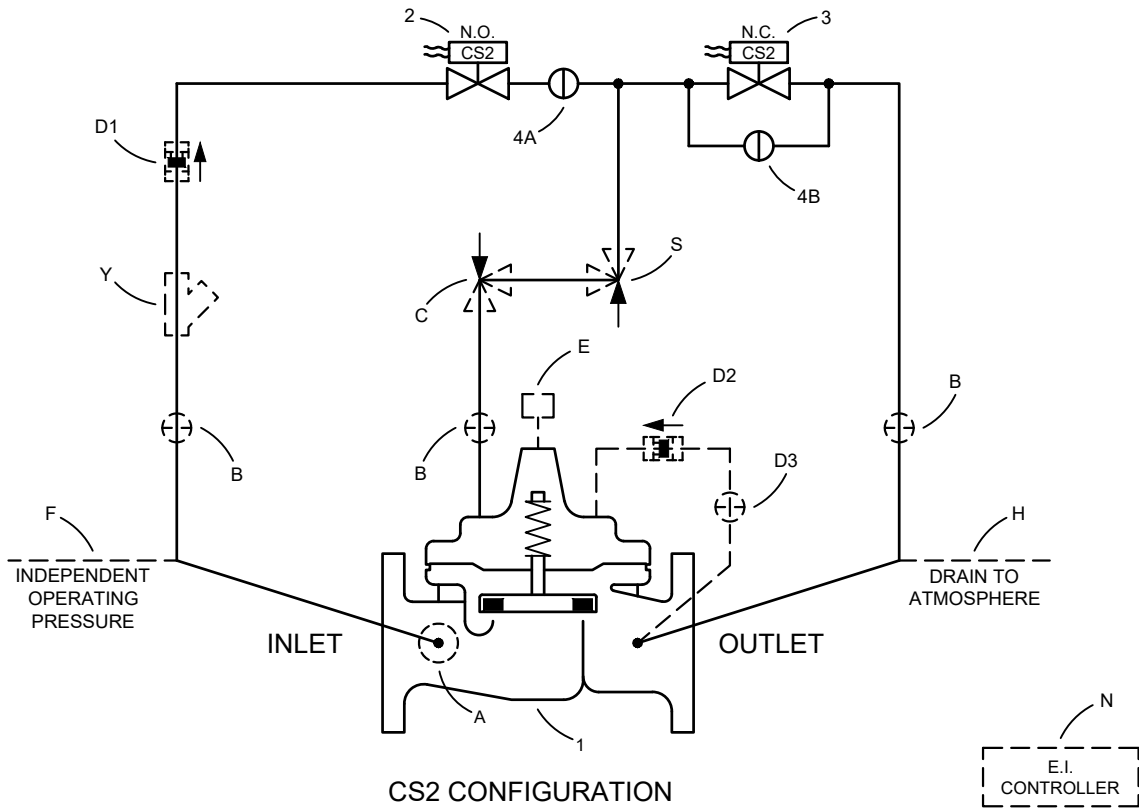

CS2 CONFIGURATION

Standard Configuration for 6" & smaller 100-01 & 8" & smaller 100-20

NO.	BASIC COMPONENTS	QTY
1	100-01 HYTROL (131-22) MAIN VALVE/100-20 HYTROL (631-22) MAIN VALVE	1
2	CS2 SOLENOID CONTROL (NORMALLY OPEN)	1
3	CS2 SOLENOID CONTROL (NORMALLY CLOSED)	1
4	CK2 COCK (SOLENOID BYPASS)	2

NO.	OPTIONAL FEATURES	QTY
A	X46A FLOW CLEAN STRAINER	1
B	CK2 COCK (ISOLATION VALVE)	3
C	CV FLOW CONTROL (CLOSING)	1
D	CHECK VALVES WITH COCK	1
E	X117D VALVE POSITION TRANSMITTER	1
F	INDEPENDENT OPERATING PRESSURE	
H	ATMOSPHERIC DRAIN	
N	ELECTRONIC CONTROLLER (VC-22D)	1
S	CV FLOW CONTROL (OPENING)	1
Y	X43 "Y" STRAINER	1

DESIGN	7-9-21	AV	F	ADDED CONFIGURATIONS CS2 & CS3 (ECO 28085)	BY	DATE
DRAWN					AK	2-16-09
CHK'D						
APVD						
E.I. CONTROLLER						
LTR						
A-D						
E						



Model **131-22/631-22**

Electronic Interface Control Valve
(Power Fail Closed)

----- NOT FURNISHED BY CLA-VAL CO. ----- OPTIONAL FEATURES

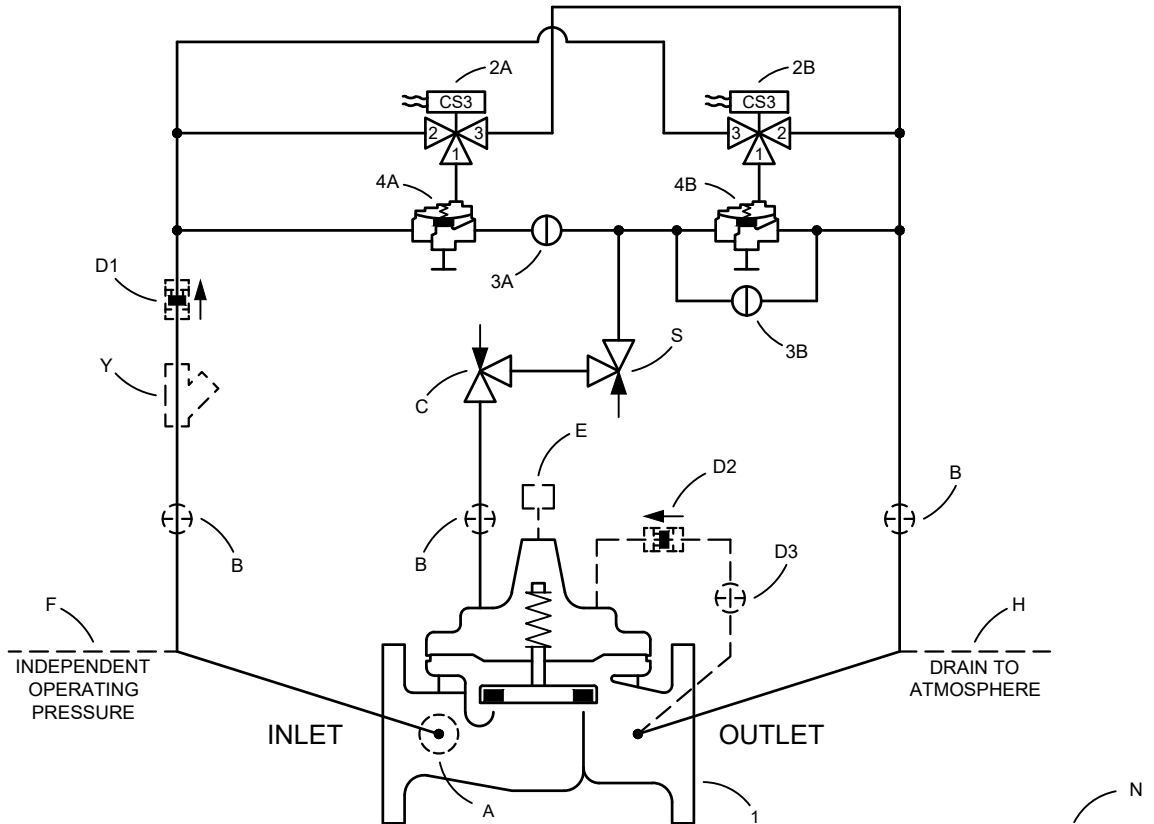

Note: C & S option required with CS3 configuration

CS3 CONFIGURATION

Standard Configuration for 8" & larger 100-01 & 10" & larger 100-20

NO.	BASIC COMPONENTS	QTY
1	100-01 HYTROL (131-22) MAIN VALVE/100-20 HYTROL (631-22) MAIN VALVE	1
2	CS3 SOLENOID CONTROL	2
3	CK2 COCK (SOLENOID BYPASS)	2
4	100-01 AUXILIARY HYTROL (REV. FLOW)	2

NO.	OPTIONAL FEATURES	QTY
A	X46A FLOW CLEAN STRAINER	1
B	CK2 COCK (ISOLATION VALVE)	3
C	CV FLOW CONTROL (CLOSING)	1
D	CHECK VALVES WITH COCK	1
E	X117D VALVE POSITION TRANSMITTER	1
F	INDEPENDENT OPERATING PRESSURE	
H	ATMOSPHERIC DRAIN	
N	ELECTRONIC CONTROLLER (VC-22D)	1
S	CV FLOW CONTROL (OPENING)	1
Y	X43 "Y" STRAINER	1

DESIGN	7-9-21	AV	F	ADDED CONFIGURATIONS CS2 & CS3 (ECO 28085)	BY	DATE
DRAWN					AK	2-16-09
CHK'D						
APVD						
E.I. CONTROLLER						
LTR						
A-D						
E						



Model 131-22/631-22

Electronic Interface Control Valve
(Power Fail Closed)

► OPERATING DATA - CONTINUED

Electronic Interface Feature: [For CS2 Configuration]

Solenoid controls (2) and (3) are direct acting, 2-way solenoid controls that change position when the coils are energized or de-energized by the electronic interface controller (N). Following paragraphs describe the opening and closing cycles of main valve (1).

Opening: When the electronic interface controller (N) energizes solenoid control (2) and (3) the N.O. solenoid control (2) closes and the N.C. solenoid control (3) opens. This relieves main valve (1) cover pressure to outlet and the main valve (1) starts to open until the electronic interface controller (N) de-energizes solenoid control (3), closing solenoid control (3), locking the main valve (1) in the desired position.

Closing: When the electronic interface controller (N) de-energizes solenoid controls (2) & (3) the N.O. solenoid control (2) opens and the N.C. solenoid control (3) close. This applies pressure to the main valve cover and the main valve (1) closes.

Electronic Interface Feature: [For CS3 Configuration]

Solenoid controls (2A) and (2B) are direct acting, 3-way solenoid controls that change position when the coils are energized or de-energized by the electronic interface controller (N). These apply or relieves pressure in the cover chambers of auxiliary hytrols (4A) & (4B). The operation shown in the following tables:

Solenoid Control (2A) & (2B)		131-22/631-22 Series		
Position	Ports Connected	Auxiliary Hytrol (4A) Position	Auxiliary Hytrol (4B) Position	Main Valve (1) Position
Energized	1 & 2	Closed	Open	Open
De-energized	1 & 3	Open	Closed	Closed

Manual Bypass Feature

Opening: Open ck2 cock (3B) and close ck2 cock (3A). This bypasses solenoid control (2B) opening the valve (1).

Closing: Open ck2 cock (3A) and close ck2 cock (3B). This applies inlet pressure to the main valve cover, closing the valve (1).

Optional Features

(A) - Flow Clean Strainer:

A self-cleaning strainer (A) is installed in the main valve inlet body boss which protects the pilot system from foreign particles.

(B) - Isolation Valves:

Isolation valves (B) are used to isolate the pilot system from main line pressure. These valves must be open during normal operation.

(C) - Closing Speed Control:

Flow control (C) controls the closing speed of the main valve. Turn the adjusting stem clockwise to make the main valve close slower.

(D) - Check Valves with Isolation Valve:

When outlet pressure is higher than inlet pressure, check valve (D2) opens and check valve (D1) closes. This directs the higher outlet pressure into the main valve cover and the main valve closes.



Model 131-22/631-22

Electronic Interface Control Valve
(Power Fail Closed)

► OPERATING DATA - CONTINUED

(E) - Position Transmitter:

Position transmitter (E) transmits a positional signal from the main valve to the electronic interface controller.

(F) - Independent Operating Pressure:

Pilot supply pressure is obtained from an independent source. (Pilot supply pressure is obtained from the main valve inlet if suffix (F) is not specified.) Note: independent operating pressure must be equal to or greater than pressure at the main valve inlet at all times.

(H) - Atmospheric Drain:

Pilot system drain line is discharged to atmosphere. (Pilot system drain line is connected to the main valve outlet boss if suffix (H) is not specified.)

(N) - Electronic Interface Controller:

Electronic interface controller (N) energizes or de-energizes the solenoid controls, opening, closing, or locking the main valve (1) in the desired position.

(S) - Opening Speed Control:

Flow control (S) controls the opening speed of the main valve. Turn the adjusting stem clockwise to make the main valve open slower.

(Y) - Y-Strainer:

A Y-Pattern strainer is installed in the pilot supply line to protect the pilot system from foreign particles. The strainer screen must be cleaned periodically.

► CHECK LIST FOR PROPER OPERATION

- System valves open upstream and downstream.
- Air removed from the main valve cover and pilot system at all high points.
- Periodical cleaning of strainer (Y) is recommended (optional feature).
- Independent operating pressure line properly connected (optional feature).
- Flow controls (C) and (S) open at least 4 turns (optional feature).
- Correct voltage to solenoid controls (2), (2A), (2B), and (3).
- Isolation valves (3B) and (4B) closed during normal operation.
- Isolation valves (3A) and (4A) open during normal operation.
- Isolation valves (B) open (optional feature).



Model 100-01 HYTROL VALVE

DESCRIPTION

The Cla-Val Model 100-01 Hytrol Valve is a main valve for Cla-Val Automatic Control Valves. It is a hydraulically operated, diaphragm-actuated, globe or angle pattern valve. This valve consists of three major components; body, diaphragm assembly, and cover. The diaphragm assembly is the only moving part. The diaphragm assembly uses a diaphragm of nylon fabric bonded with synthetic rubber. A synthetic rubber disc, contained on three and one half sides by a disc retainer and disc guide, forms a seal with the valve seat when pressure is applied above the diaphragm. The diaphragm assembly forms a sealed chamber in the upper portion of the valve, separating operating pressure from line pressure.

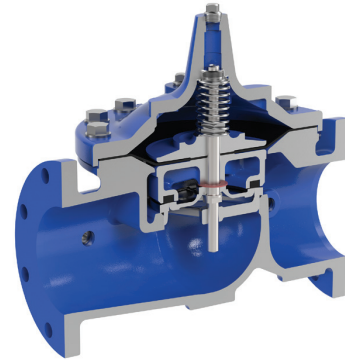

Installation

1. Before valve is installed, pipe lines should be flushed of all chips, scale and foreign matter.
2. It is recommended that either gate or block valves be installed on both ends of the Model 100-01 Hytrol Valve to facilitate isolating the valve for preventive maintenance and repairs.
3. Place the valve in the line with flow through the valve in the direction indicated on the inlet nameplate. (See "Flow Direction" Section) **Note: Valve can be installed in the vertical or horizontal position.**
4. Allow sufficient room around valve to make adjustments and for disassembly.
5. Cla-Val Model 100-01 Hytrol Valves operate with maximum efficiency when mounted in horizontal piping with the cover UP, however, other positions are acceptable. Due to size and weight of the cover and internal components of 8 inch and larger valves, installation with the cover UP is advisable. This makes internal parts readily accessible for periodic inspection.

6. Caution must be taken in the installation of this valve to insure that galvanic and/or electrolytic action does not take place. The proper use of dielectric fittings and gaskets are required in all systems using dissimilar metals.
7. If a pilot control system is installed on the Model 100-01 Hytrol Valve, use care to prevent damage. If it is necessary to remove fittings or components, be sure they are kept clean and replaced exactly as they were.
8. After the valve is installed and the system is first pressurized, vent air from the cover chamber and pilot system tubing by loosening fittings at all high points.

Principles of Operation

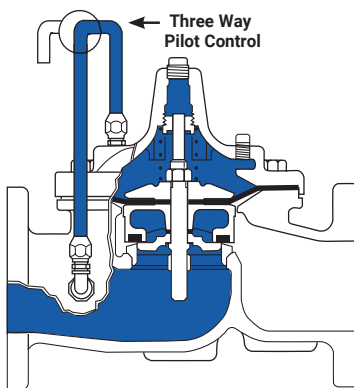

Tight Closing Operation

When pressure from the valve inlet (or an equivalent independent operating pressure) is applied to the diaphragm chamber the valve closes drip-tight.

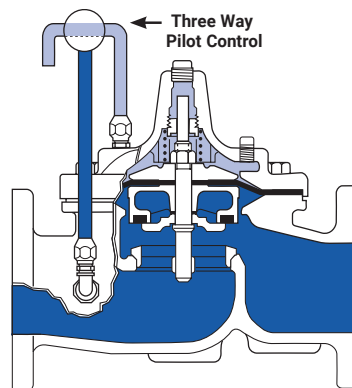

Full Open Operation

When pressure in diaphragm chamber is relieved to a zone of lower pressure (usually atmosphere) the line pressure (5 psi Min.) at the valve inlet opens the valve.

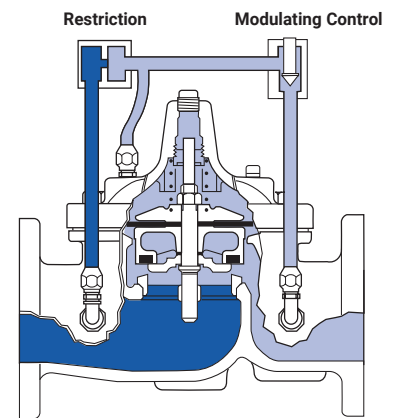

Modulating Action

Valve modulates when diaphragm pressure is held at an intermediate point between inlet and discharge pressure. With the use of a Cla-Val. "Modulating control," which reacts to line pressure changes, the pressure above the diaphragm is varied, allowing the valve to throttle and compensate for the change.

Flow Direction

The flow through the Model 100-01 Hytrol Valve can be in one of two directions. When flow is “up-and-over the seat,” it is in “normal” flow and the valve will fail in the open position. When flow is “over-the seat-and down,” it is in “reverse” flow and the valve will fail in the closed position. There are no permanent flow arrow markings. **The valve must be installed according to nameplate data.**

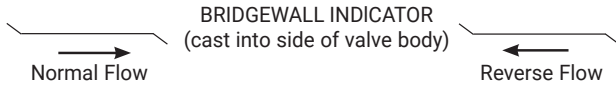

Recommended Tools

1. Three pressure gauges with ranges suitable to the installation to be put at Hytrol inlet, outlet and cover connections.
2. Cla-Val Model X101D Valve Position Indicator. This provides visual indication of valve position without disassembly of valve.
3. Other items are: suitable hand tools such as screwdrivers, wrenches, etc., soft jawed (brass or aluminum) vise, 400 grit wet or dry sandpaper and water for cleaning.

Troubleshooting

The following troubleshooting information deals strictly with the Model 100-01 Hytrol Valve. This assumes that all other components of the pilot control system have been checked out and are in proper working condition. (See appropriate sections in Technical Manual for complete valve).

All trouble shooting is possible without removing the valve from the line or removing the cover. It is highly recommended to permanently install a Model X101D Valve Position Indicator and three gauges in unused Hytrol inlet, outlet and cover connections.

After checking out probable causes and remedies, the following three checks can be used to diagnose the nature of the problem before maintenance is started. They must be done in the order shown.

Service Suggestions		
Symptom	Possible Cause	Solutions
Fails to Close	Closed isolation valves in control system, or in main line.	Open Isolation valves.
	Lack of cover chamber pressure	Check upstream pressure, pilot system, strainer, tubing, valves, or needle valves for obstruction.
	Diaphragm damaged. (See Diaphragm Check.)	Replace diaphragm.
	Diaphragm assembly inoperative. Corrosion or excessive scale build up on valve stem. (See Freedom of Movement Check)	Clean and polish stem. Inspect and replace any damaged or badly eroded part.
	Mechanical obstruction. Object lodged in valve. (See Freedom of Movement Check)	Remove obstruction.
	Worn disc. (See Tight Sealing Check)	Replace disc.
	Badly scored seat (See Tight Sealing Check)	Replace seat.
Fails to Open	Closed upstream and/or downstream isolation valves in main line.	Open isolation valves.
	Insufficient line pressure.	Check upstream pressure. (Minimum 5 psi flowing line pressure differential.)
	Diaphragm assembly inoperative. Corrosion or excessive buildup on valve stem. (See Freedom of Movement Check)	Clean and polish stem. Inspect and replace any damaged or badly eroded part.
	Diaphragm damaged. (For valves in “reverse flow” only)	Replace diaphragm.

Three Checks

The Model 100-01 Hytrol Valve has only one moving part (the diaphragm and disc assembly). So, there are only three major types of problems to be considered.

First: Valve is stuck - that is, the diaphragm assembly is not free to move through a full stroke either from open to close or vice versa.

Second: Valve is free to move and can't close because of a worn out diaphragm.

Third: Valve leaks even though it is free to move and the diaphragm isn't leaking.

CAUTION: Care should be taken when doing the troubleshooting checks on the Model 100-01 Hytrol Valve. These checks do require the valve to open fully. This will either allow a high flow rate through the valve, or the downstream pressure will quickly increase to the inlet pressure. In some cases, this can be very harmful. Where this is the case, and there are no block valves in the system to protect the downstream piping, it should be realized that **the valve cannot be serviced under pressure**. Steps should be taken to remedy this situation before proceeding any further.



Three Checks (cont.)

DIAPHRAGM CHECK (#1)

1. Shut off pressure to the Hytrol Valve by slowly closing upstream and downstream isolation valves. **SEE CAUTION.**
2. Disconnect or close all pilot control lines to the valve cover and leave only one fitting in highest point of cover open to atmosphere.
3. With the cover vented to atmosphere, slowly open upstream isolation valve to allow some pressure into the Hytrol Valve body. Observe the open cover tapping for signs of continuous flow. It is not necessary to fully open isolating valve. Volume in cover chamber capacity chart will be displaced as valve moves to open position. Allow sufficient time for diaphragm assembly to shift positions. If there is no continuous flow, you can be quite certain the diaphragm is sound and the diaphragm assembly is tight. If the fluid appears to flow continuously this is a good reason to believe the diaphragm is either damaged or it is loose on the stem. In either case, this is sufficient cause to remove the valve cover and investigate the leakage. (See "Maintenance" section for procedure.)

Cover Chamber Capacity (Liquid Volume displaced when valve opens)		
Valve Size (Inches)	Displacement	
	Gallons	Liters
1-1/4"	0.020	0.07
1-1/2"	0.020	0.07
2"	0.032	0.12
2-1/2"	0.043	0.16
3"	0.080	0.30
4"	0.169	0.64
6"	0.531	2.0
8"	1.26	4.8
10"	2.51	9.5
12"	4.00	15.1
14"	6.50	24.6
16"	9.57	36.0
18"	11.00	41.6
20"	12.00	45.4
24"	29.00	109.8
30"	42.00	197.0
36"	90.00	340.0

FREEDOM OF MOVEMENT CHECK (#2)

4. Determining the Hytrol Valve's freedom of movement can be done by one of two methods.
5. For most valves it can be done after completing Diaphragm Check (Steps 1, 2, and 3). **SEE CAUTION.** At the end of step 3 the valve should be fully open.
6. If the valve has a Cla-Val X101D Position Indicator, observe the indicator to see that the valve opens wide. Mark the point of maximum opening.
7. Re-connect enough of the control system to permit the application of inlet pressure to the cover. Open pilot system cock so pressure flows from the inlet into the cover.
8. While pressure is building up in the cover, the valve should close smoothly. There is a hesitation in every Hytrol Valve closure, which can be mistaken for a mechanical bind. The stem will appear to stop moving very briefly before going to the closed position. This slight pause is caused by the diaphragm flexing at a particular point in the valve's travel and is not caused by a mechanical bind.
9. When closed, a mark should be made on the X101D Valve position indicator corresponding to the "closed" position. The distance between the two marks should be approximately the stem travel shown in chart.
10. If the stroke is different than that shown in stem travel chart this is a good reason to believe something is mechanically restricting the stroke of the valve at one end of its travel. If the flow does not

stop through the valve when in the indicated "closed" position, the obstruction probably is between the disc and the seat. If the flow does stop, then the obstruction is more likely in the cover. In either case, the cover must be removed, and the obstruction located and removed. The stem should also be checked for scale build-up. (See "Maintenance" section for procedure.)

Stem Travel (Fully open to fully closed)			
Valve Size (Inches)		Travel (Inches)	
Inches	MM	Inches	MM
1-1/4"	32	0.04"	10
1-1/2"	40	0.04"	10
2"	50	0.06"	15
2-1/2"	65	0.07"	18
3"	80	0.08"	20
4"	100	1.1"	28
6"	150	1.7"	43
8"	200	2.3"	58
10"	250	2.8"	71
12"	300	3.4"	86
14"	350	4.0"	100
16"	400	4.5"	114
18"	450	5.1"	130
20"	500	5.6"	143
24"	600	6.7"	165
30"	800	7.5"	190
36"	900	8.5"	216

11. For valves 6" and smaller, the Hytrol Valve's freedom of movement check can also be done after all pressure is removed from the valve. **SEE CAUTION.** After closing inlet and outlet isolation valves and bleeding pressure from the valve, check that the cover chamber and the body are temporarily vented to atmosphere. Insert fabricated tool into threaded hole in top of valve stem, and lift the diaphragm assembly manually. Note any roughness. The diaphragm assembly should move smoothly throughout entire valve stroke. The tool is fabricated from rod that is threaded on one end to fit valve stem and has a "T" bar handle of some kind on the other end for easy gripping. (See chart in Step 4 of "Disassembly" Section.)
12. Place marks on this diaphragm assembly lifting tool when the valve is closed and when manually positioned open. The distance between the two marks should be approximately the stem travel shown in stem travel chart. If the stroke is different than that shown, there is a good reason to believe something is mechanically restricting the stroke of the valve. The cover must be removed, and the obstruction located and removed. The stem should also be checked for scale build-up. (See "Maintenance" section for procedure.)

TIGHT SEALING CHECK (#3)

13. Test for seat leakage after completing checks #1 & #2 (Steps 1 to 12). **SEE CAUTION.** Close the isolation valve downstream of the Hytrol Valve. Apply inlet pressure to the cover of the valve, wait until it closes. Install a pressure gauge between the two closed valves using one of the two ports in the outlet side of the Hytrol. Watch the pressure gauge. If the pressure begins to climb, then either the downstream isolation valve is permitting pressure to creep back, or the Hytrol is allowing pressure to go through it. Usually the pressure at the Hytrol inlet will be higher than on the isolation valve discharge, so if the pressure goes up to the inlet pressure, you can be sure the Hytrol is leaking. Install another gauge downstream of isolating valve. If the pressure between the valves only goes up to the pressure on the isolation valve discharge, the Hytrol Valve is holding tight, and it was just the isolation valve leaking.



Maintenance

PREVENTATIVE MAINTENANCE

The Cla-Val Model 100-01 Hytrol Valve requires no lubrication or packing and a minimum of maintenance. However, a periodic inspection schedule should be established to determine how the operating conditions of the system are affecting the valve. The effect of these actions must be determined by inspection.

DISASSEMBLY

Inspection or maintenance can be accomplished without removing the valve from the line. Repair kits with new diaphragm and disc are recommended to be on hand before work begins.

WARNING: Maintenance personnel can be injured and equipment damaged if disassembly is attempted with pressure in the valve. **SEE CAUTION.**

1. Close upstream and downstream isolation valves and **independent operating pressure when used** to shut off all pressure to the valve.
2. Loosen tube fittings in the pilot system to remove pressure from valve body and cover chamber. After pressure has been released from the valve, use care to remove the controls and tubing. Note and sketch position of tubing and controls for re-assembly. The schematic in front of the Technical Manual can be used as a guide when reassembling pilot system.
3. Remove cover nuts and remove cover. If the valve has been in service for any length of time, chances are the cover will have to be loosened by driving upward along the edge of the cover with a **dull cold chisel**.

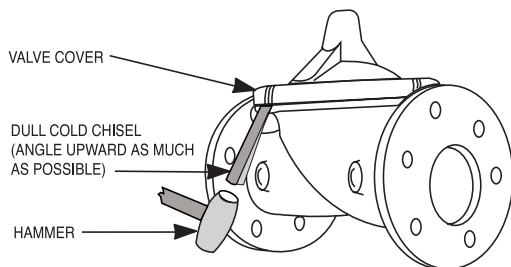

On 6" and smaller valves block and tackle or a power hoist can be used to lift valve cover by inserting proper size eye bolt in place of the center cover plug. on 8" and larger valves there are 4 holes (5/8" – 11 size) where jacking screws and/or eye bolts may be inserted for lifting purposes. **Pull cover straight up** to keep from damaging the integral seat bearing and stem.

Cover Center Plug Size	
Valve Size (Inches)	Thread Size (NPT)
1-1/4" - 1-1/2"	1/4"
2" - 3"	1/2"
4" - 6"	3/4"
8" - 10"	1"
12"	1-1/4"
14"	1-1/2"
16"	2"
18" - 24"	1"
30" & 36"	2"

4. Remove the diaphragm and disc assembly from the valve body. With smaller valves this can be accomplished by hand by **pulling straight up on the stem so as not to damage the seat bearing**. On large valves, an eye bolt of proper size can be installed in the stem and the diaphragm assembly can be then lifted with a block and tackle or power hoist. Take care not to damage the stem or bearings. The valve won't work if these are damaged.

Valve Stem Thread Size	
Valve Size (Inches)	Thread Size (UNF Internal)
1-1/4" - 2-1/2"	10 - 32
3" - 4"	1/4 - 28
6" - 14"	3/8 - 24
16"	1/2 - 20
18"	3/4 - 16
20"	3/4 - 16
24"	3/4 - 16
30"	3/4 - 16
36"	3/4 - 16

5. The next item to remove is the stem nut. Examine the stem threads above the nut for signs of mineral deposits or corrosion. If the threads are not clean, use a wire brush to remove as much of the residue as possible. Attach a good fitting wrench to the nut and give it a sharp "rap" rather than a steady pull. Usually several blows are sufficient to loosen the nut for further removal. On the smaller valves, the entire diaphragm assembly can be held by the stem in a vise **equipped with soft brass jaws** before removing the stem nut.

The use of a pipe wrench or a vise without soft brass jaws scars the fine finish on the stem. No amount of careful dressing can restore the stem to its original condition. Damage to the finish of the stem can cause the stem to bind in the bearings and the valve will not open or close.

6. After the stem nut has been removed, the diaphragm assembly breaks down into its component parts. Removal of the disc from the disc retainer can be a problem if the valve has been in service for a long time. Using two screwdrivers inserted along the outside edge of the disc usually will accomplish its removal. Care should be taken to preserve the spacer washers in water, particularly if no new ones are available for re-assembly.

7. The only part left in the valve body is the seat which ordinarily does not require removal. Careful cleaning and polishing of inside and outside surfaces with 400 wet/dry sandpaper will usually restore the seat's sharp edge. If, however, it is badly worn and replacement is necessary, it can be easily removed.

Seats in valve sizes 1 1/4" through 6" are threaded into the valve body. They can be removed with accessory X109 Seat Removing Tool available from the factory. On 8" and larger valves, the seat is held in place by flat head machine screws. Use a tight-fitting, long shank screwdriver to prevent damage to seat screws. If upon removal of the screws the seat cannot be lifted out, it will be necessary to use a piece of angle or channel iron with a hole drilled in the center. Place it across the body so a long stud can be inserted through the center hole in the seat and the hole in the angle iron. By tightening the nut a uniform upward force is exerted on the seat for removal.

NOTE: Do not lift up on the end of the angle iron as this may force the integral bearing out of alignment, causing the stem to bind.

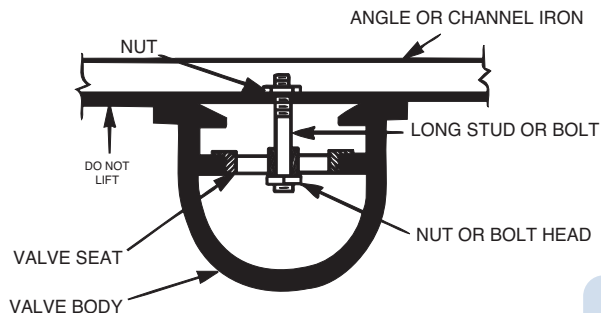

Lime Deposits

One of the easiest ways to remove lime deposits from the valve stem or other metal parts is to dip them in a 5-percent muriatic acid solution just long enough for the deposit to dissolve. This will remove most of the common types of deposits. **CAUTION: USE EXTREME CARE WHEN HANDLING ACID.** Rinse parts in water before handling. If the deposit is not removed by acid, then a fine grit (400) wet or dry sandpaper can be used with water.

Inspection of Parts

After the valve has been disassembled, each part should be examined carefully for signs of wear, corrosion, or any other abnormal condition. Usually, it is a good idea to replace the rubber parts (diaphragm and disc) unless they are free of signs of wear. These are available in a repair kit. Any other parts which appear doubtful should be replaced. **WHEN ORDERING PARTS, BE SURE TO GIVE COMPLETE NAMEPLATE DATA, ITEM NUMBER AND DESCRIPTION.**

NOTE: If a new disc isn't available, the existing disc can be turned over, exposing the unused surface for contact with the seat. The disc should be replaced as soon as practical.

Reassembly

1. Reassembly is the reverse of the disassembly procedure. If a new disc has been installed, it may require a different number of spacer washers to obtain the right amount of "grip" on the disc. When the diaphragm assembly has been tightened to a point where the diaphragm cannot be twisted, the disc should be compressed very slightly by the disc guide. Excessive compression should be avoided. Use just enough spacer washers to hold the disc firmly without noticeable compression.

2. **MAKE SURE THE STEM NUT IS VERY TIGHT.** Attach a good fitting wrench to the nut and give it a sharp "rap" rather than a steady pull. Usually several blows are sufficient to tighten the stem nut for final tightening. Failure to do so could allow the diaphragm to pull loose and tear when subjected to pressure.

3. Carefully install the diaphragm assembly by lowering the stem through the seat bearing. Take care not to damage the stem or bearing. Line up the diaphragm holes with the stud or bolt holes on the body. On larger valves with studs, it may be necessary to hold the diaphragm assembly up part way while putting the diaphragm over the studs.

4. Put spring in place and replace cover. Make sure diaphragm is lying smooth under the cover.

5. Tighten cover nuts firmly using a cross-over pattern until all nuts are tight.

6. Test Hytrol Valve before re-installing pilot valve system.

Test Procedure After Valve Assembly

There are a few simple tests which can be made in the field to make sure the Hytrol Valve has been assembled properly. Do these before installing pilot system and returning valve to service. These are similar to the three troubleshooting tests.

1. Check the diaphragm assembly for freedom of movement after all pressure is removed from the valve. **SEE CAUTION.** Insert fabricated tool into threaded hole in top of valve stem, and lift the diaphragm assembly manually. Note any roughness, sticking or grabbing. The diaphragm assembly should move smoothly throughout entire valve stroke. The tool is fabricated from rod that is threaded on one end to fit valve stem (See chart in Step 4 of "Disassembly" section.) and has a "T" Bar handle of some kind on the other end for easy gripping.

Place marks on this diaphragm assembly lifting tool when the valve is closed and when manually positioned open. The distance between the two marks should be approximately the stem travel shown in stem travel chart. (See "Freedom of Movement Check" section.) If the stroke is different than that shown, there is a good reason to believe something is mechanically restricting the stroke of the valve. The cover must be removed, the obstruction located and removed. (See "Maintenance" section for procedure.)

Due to the weight of the diaphragm assembly this procedure is not possible on valves 8" and larger. on these valves, the same determination can be made by carefully introducing a low pressure-less than five psi) into the valve body with the cover vented. **SEE CAUTION.** Looking in cover center hole see the diaphragm assembly lift easily without hesitation, and then settle back easily when the pressure is removed.

2. To check the valve for drip-tight closure, a line should be connected from the inlet to the cover, and pressure applied at the inlet of the valve. If properly assembled, the valve should hold tight with as low as ten PSI at the inlet. (See "Tight Sealing Check" section.)

3. With the line connected from the inlet to the cover, apply full working pressure to the inlet. Check all around the cover for any leaks. Re-tighten cover nuts if necessary to stop leaks past the diaphragm.

4. Remove pressure, then re-install the pilot system and tubing exactly as it was prior to removal. **Bleed air from all high points.**

5. Follow steps under "Start-Up and Adjustment" Section in Technical Manual for returning complete valve back to service.



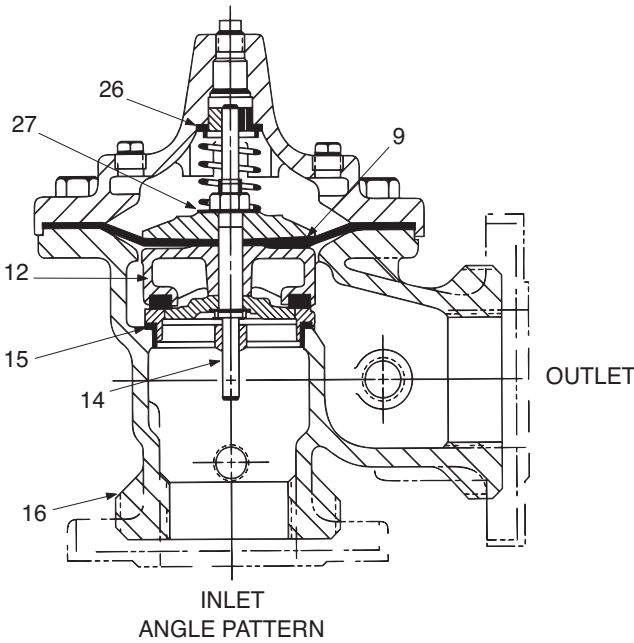
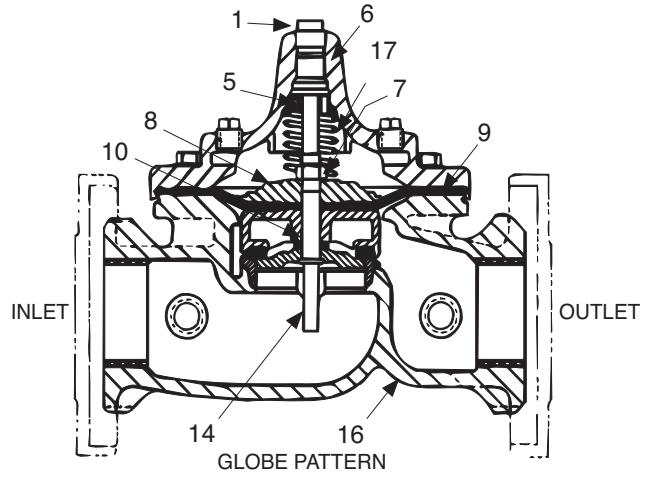
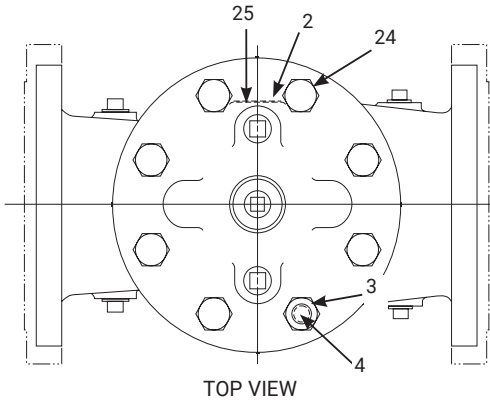

Item No.	Description
1	Pipe Plug
2	Drive Screws (for nameplate)
3	Hex Nut (8" and larger)
4	Stud (8" and larger)
5	Cover Bearing
6	Cover
7	Stem Nut
8	Diaphragm Washer
9	Diaphragm
10	Spacer Washers
11	Disc Guide
12	Disc Retainer
13	Disc
14	Stem
15	Seat
16	Body
17	Spring
22	Flat Head Screws (8" and larger)
23	Seat O-Ring
24	Hex Head Bolt (1-1/4" thru 4")
25	Nameplate
26	Upper Spring Washer (Epoxy coated valves only)
27	Lower Spring Washer (Epoxy coated valves only)
28	Cover Bearing Housing (16" only)
29	Cover O-Ring (16" only)
30	Hex Bolt (16" only)
31	Pipe Cap (16" only)

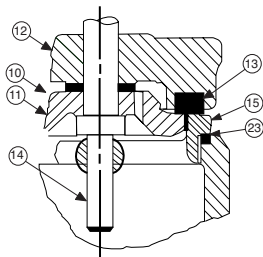

1-1/4" - 6" SEAT DETAIL

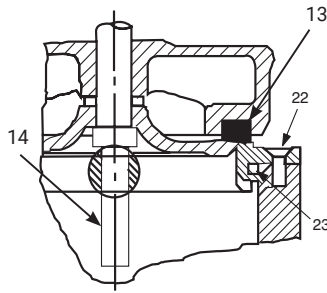

8" - 24" SEAT DETAIL

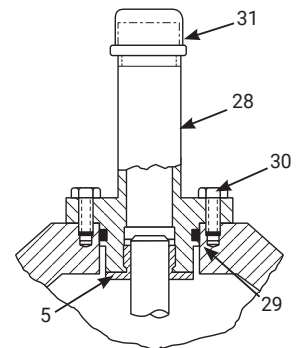

16" COVER DETAIL





Model 100-01 HYTROL VALVE SERVICE DATA

DESCRIPTION 100-01 HYTROL VALVE

The Cla-Val Model 100-01 Hytrol Valve is a main valve for Cla-Val Automatic Control Valves. It is a hydraulically operated, diaphragm-actuated, globe or angle pattern valve. This valve consists of three major components; body, diaphragm assembly, and cover. The diaphragm assembly is the only moving part. The diaphragm assembly uses a diaphragm of nylon fabric bonded with synthetic rubber. A synthetic rubber disc, contained on three and one half sides by a disc retainer and disc guide, forms a seal with the valve seat when pressure is applied above the diaphragm. The diaphragm assembly forms a sealed chamber in the upper portion of the valve, separating operating pressure from line pressure.



DESCRIPTION 100-20 600 SERIES HYTROL VALVE

The Cla-Val Model 100-20 Hytrol Valve (600 Series main valve) have only one part -the body- that is different from standard 100 Series Cla-Val main valve parts. The remaining parts of the 600 series main valve are standard Cla-Val main valve parts. All service and maintenance information for the standard 100 Series main valves also apply to the 600 series main valves. The most important thing to remember when ordering main valve repair kits and replacement parts, except for the body, all other parts are going to be for a smaller size main valve. Cla-Val identifies main valve parts with the flange size of the standard 100 Series main valve. Refer to the "Main Valve Sizes" chart below.

Hytrol Service Data

Hytrol Service Data																			
Hytrol Size				Stem Travel		Cover Capacity Displacement		Cover Center NPT	Cover Nut or Bolt ⁽¹⁾					Cover Lifting Holes	Valve Stem Internal Thread	Stem Nut ⁽³⁾			
100-01		100-20							Thread	Socket	Qty	Torque, Lubricated ⁽²⁾				Thread	Socket (Long)	Torque, Lubricated ⁽²⁾	
IN	MM	IN	MM	IN	MM	Gallons	Liters					FT. LBS	IN. LBS			FT. LBS	IN. LBS		
1	25	—	—	0.24	6	0.02	—	1/4	1/4 - 20	7/16	8	—	80	—	—	3/8 - 24	9/16	—	80
1 1/4	32	—	—	0.49	12	0.02	0.08	1/4	5/16 - 18	1/2	8	12	—	—	#10 - 32	7/16 - 20	11/16	12	—
1 1/2	40	—	—	0.49	12	0.02	0.08	1/4	5/16 - 18	1/2	8	12	—	—	#10 - 32	7/16 - 20	11/16	12	—
2	50	3	80	0.59	15	0.03	0.12	1/2	3/8 - 16	9/16	8	20	—	—	#10 - 32	1/2 - 20	3/4	16	—
2 1/2	65	—	—	0.71	18	0.04	0.16	1/2	7/16 - 14	5/8	8	36	—	—	#10 - 32	5/8 - 18	15/16	32	—
3	80	4	—	0.84	21	0.08	0.3	1/2	1/2 - 13	3/4	8	50	—	—	1/4 - 28	5/8 - 18	15/16	32	—
4	100	6	—	1.09	28	0.17	0.64	3/4	3/4 - 10	1 1/8	8	125	—	—	1/4 - 28	3/4 - 16	1 1/8	55	—
6	150	8	—	1.58	40	0.53	2.01	3/4	3/4 - 10	1 1/8	12	125	—	—	3/8 - 24	7/8 - 14	1 5/16	100	—
8	200	10	—	2.24	57	1.26	4.77	1	3/4 - 10	1 1/4	16	125	—	5/8 - 11	3/8 - 24	1 1/8 - 12	1 3/4	180	—
10	250	12	—	2.71	69	2.51	9.5	1	7/8 - 9	1 7/16	20	160	—	3/4 - 10	3/8 - 24	1 1/4 - 12	1 7/8	300	—
12	300	14, 16	350, 400	3.34	85	4.00	15.14	1 1/4	1 1/8 - 7	1 13/16	20	320	—	3/4 - 10	3/8 - 24	1 1/2 - 12	2 1/4	500	—
14	350	—	—	4.08	104	6.50	24.61	1 1/2	1 1/4 - 7	2	20	450	—	1 - 8	3/8 - 24	1 1/2 - 12	2 1/4	500	—
16	400	18, 20, 24	450, 500, 600	4.58	116	9.60	36.34	2	1 1/4 - 7	2	20	450	—	1 - 8	1/2 - 20	2 - 16	3	600	—
18	500	—	—	5.13	130	11.00	42	1	1 1/4 - 7	2	24	450	—	1 - 8	3/4 - 16	2 1/4 - 16	3 7/16	1000	—
20	500	—	—	5.63	143	12.00	45.42	1	1 3/8 - 6	2 3/16	24	600	—	1 - 8	3/4 - 16	2 1/4 - 16	3 7/16	1000	—
24	600	30	—	6.50	165	29.00	109.78	1	1 1/2 - 12	2 3/8	24	850	—	1 1/8 - 7	3/4 - 16	3 - 12	4 5/8	1600	—
30	750	36	900	8.00	203	42.00	158.99	2	1 1/2 - 12	2 3/8	32	850	—	1 1/8 - 7	3/4 - 16	3 - 12	4 5/8	3000	—
36	900	42, 48, 56	1050, 1200, 1400	8.71	221	90.00	340.69	2	1 3/4 - 10	2 3/4	36	1250	—	1 1/4 - 12	3/4 - 16	3 1/2 - 8	6	3000	—

(1) Valve sizes 6" and smaller use hex bolts for cover fasteners. Valve sizes 8" and larger use studs with hex nuts.

(2) Clean all threads and apply anti-seize prior to reassembly of threaded fasteners. Torque values are based on standard SST material.

(3) Only stem nuts supplied by CLA-VAL shall be used.



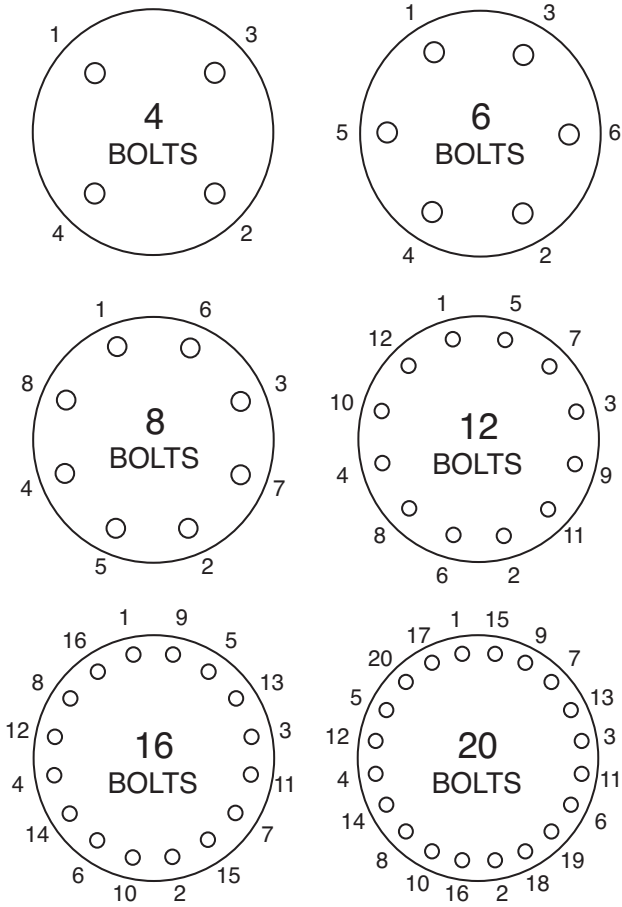

- Follow this procedure when reassembling Main Valve:
- Tightens bolts/nuts in a "Star" or "Cross-Over" pattern following the numbers shown above to insure that cover seats evenly on the diaphragm material and body.
 - Torque the bolt/nuts in three stages with a "Star" or "Cross-Over" pattern for each stage:
 - To approximately 10% of final torque.
 - To approximately 75% of final torque.
 - To final required torque.
 - Valves that are to be tested to 375 PSI or higher should be re-torqued after 24 hours.

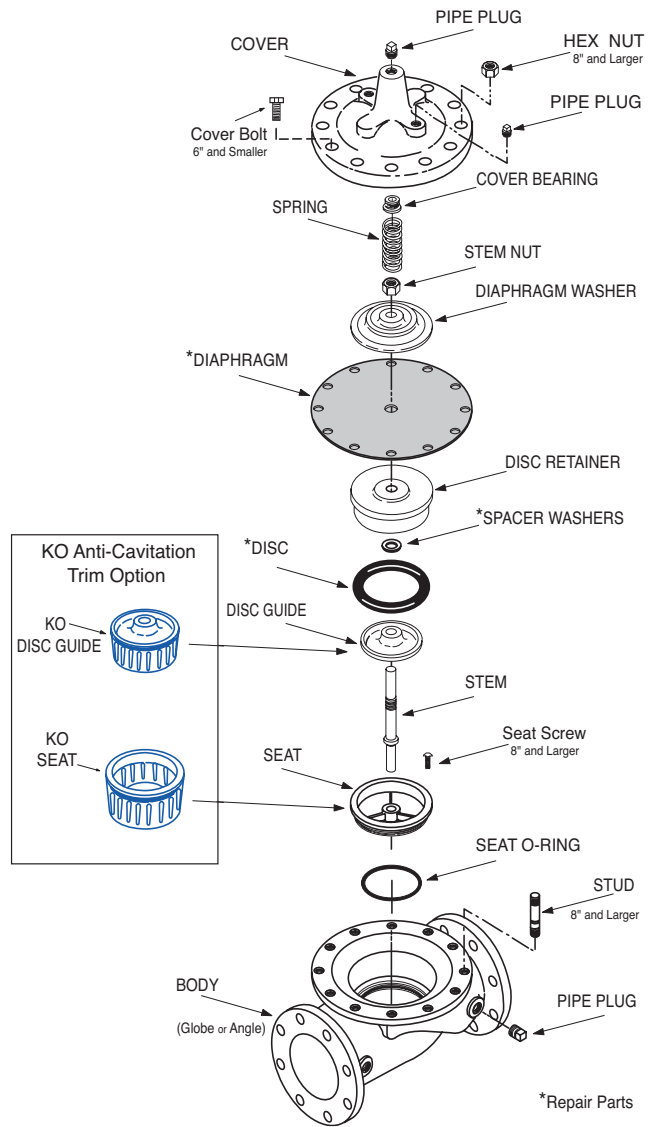



— MODEL — **100-20**
(Reduced Internal Port)

600 Series Hytrol Valve

SERVICE AND MAINTENANCE OF 600 SERIES VALVES

The 600 series main valves have only one part -the body- that is different from standard 100 Series Cla-Val main valve parts. The remaining parts of the 600 series main valve are standard Cla-Val main valve parts. All service and maintenance information for the standard 100 Series main valves in this manual also apply to the 600 series main valves.

The most important thing to remember when ordering main valve repair kits and replacement parts, except for the body, all other parts are going to be for a smaller size main valve. Cla-Val identifies main valve parts with the flange size of the standard 100 Series main valve. Refer to the "Main Valve Sizes Comparison" chart. For example, if you are servicing a 6" 100-20 Hytrol and needed a repair kit, you would order a repair kit for a 4" 100-01 Hytrol. This kit is also suitable for a 6" 100-20 Hytrol. Complete Technical Manuals include a repair kit data sheet N-RK that shows this relationship.

When you order repair parts, it is a good idea to include valve nameplate data (size, catalog number, and part number) and description of the parts desired. Do this to be sure parts will fit the valve you are working on and not be too big for it. Pilot controls and repair kits maintenance information remain the same for 100 or 600 Series valves.

UNDERSTANDING THE 600 SERIES VALVES

In 1987, Cla-Val introduced the Model 100-20 Hytrol as the basic main valve for the 600 Series of automatic control valves. To identify all new valves using the 100-20 Hytrol, an existing catalog number is modified. Making a 600 Series catalog number is simply done by using a "6" in front of the two digit catalog numbers or replacing the "2" with a "6" in three digit catalog numbers. Current schematics reflect both catalog numbers together separated by a slash (i.e. - 90-01/690-01, 58-02/658-02, 210-01/610-01, etc). Since these two valves 'share' the same catalog number and schematic, they provide the same function in a system. The only difference between the two valves is the relative capacity of the two main valve series.

The 100-01 Hytrol is the basic main valve for Cla-Val automatic control valves. This valve is the current version of the Clayton Hytrol valve design originated in 1936. The 100-01 Hytrol is designed as a full flow area valve. This means that the inlet, seat and outlet openings are the same size. Thus, the pressure drop is kept to a minimum for this globe style design.

The 100-20 Hytrol valve has all of the basic features and advantages of the original 100-01 Hytrol. Only one part has been changed - the body. It is designed with different size inlet, seat and outlet openings. The 100-20 Hytrol has inlet and outlet flanges one valve size larger than the seat opening size. This results in what is sometimes called a 'reduced port' main valve. For example, a 4" 100-20 valve has a 3" seat. Note: valve size is always determined by the flange size. The following chart compares the 100-01 and the 100-20 main valves.

Basic Main Valve Size Comparison		
Globe Pattern Valves		
Flange Size (inch)	Seat Size	
	100-01 (100 Series)	100-20 (600 Series)
3	3	2
4	4	3
6	6	4
8	8	6
10	10	8
12	12	10
14	14	----
16	16	12
18	----	16
20	20	16
24	24	16
30	30	24
36	36	30
42	----	36
48	----	36
Angle Pattern Valves		
Flange Size (inch)	Seat Size	
	100-01 (100 Series)	100-20 (600 Series)
4	4	3
6	6	4
8	8	6

The 100-20 Hytrol is available only in ductile iron, 150 and 300 pressure class, and Bronze trim standard. Available extra cost main valve options include stainless steel trim, epoxy coating, Dura-Kleen stem, Delrin sleeved stem, and high temperature rubber parts. All four basic main valves have a 600 Series version available with all of the same benefits and size relationships. The following chart shows the relationship of Cla-Val main valve catalog numbers.

Cla-Val Main Valves

Catalog Name	Catalog Number		
	Circa 1936	100-Series	600 Series
Hytrol	100 (Angle =2100)	100-01	100-20
Powertrol	100P & 100PA	100-02	100-21
Powercheck	100PC & 100PCA	100-03	100-22
Hycheck	181	100-04	100-23

100-20

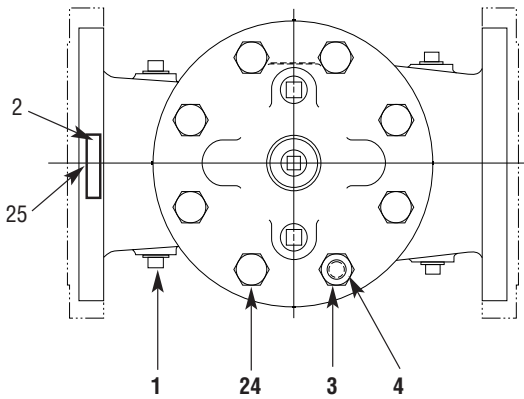

TOP VIEW

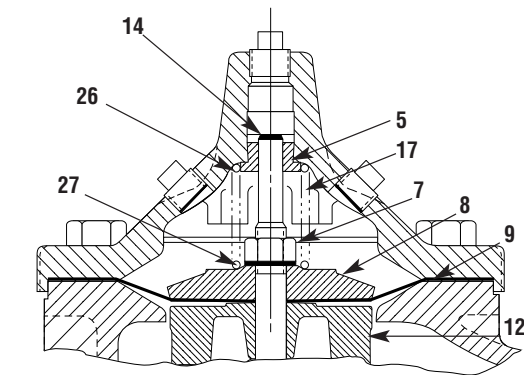
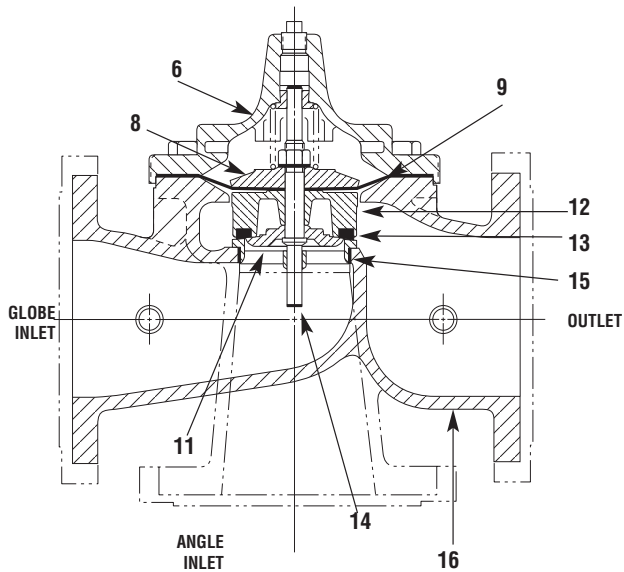

3" - 6" COVER DETAIL

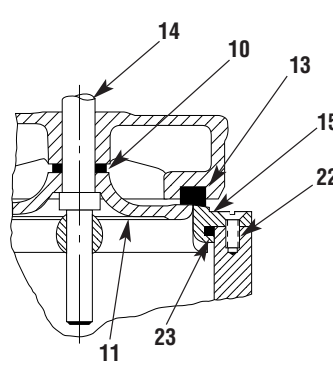

10" - 24" SEAT DETAIL

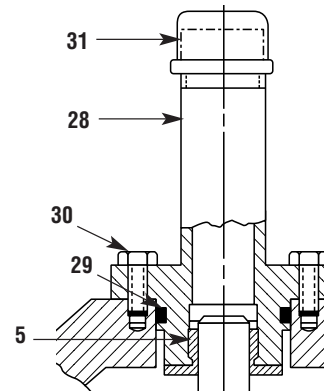

20" - 24" COVER DETAIL

PARTS LIST

NO. DESCRIPTION

- 1 Pipe Plug
- 2 Drive Screws (for nameplate)
- 3 Hex Nut (8" and larger)
- 4 Stud (8" and larger)
- 5 Cover Bearing
- 6 Cover
- 7 Stem Nut
- 8 Diaphragm Washer
- 9 Diaphragm
- 10 Spacer Washers
- 11 Disc Guide
- 12 Disc Retainer
- 13 Disc
- 14 Stem
- 15 Seat
- 16 Body
- 17 Spring
- 22 Flat Head Screws (10" and larger)
- 23 Seat O-Ring
- 24 Hex Bolt (3" Thru 6")
- 25 Nameplate (Mounted on inlet flange)
- 26 Upper Spring Washer (Epoxy coated valves only)
- 27 Lower Spring Washer (Epoxy coated valves only)
- 28 Cover Bearing Housing (20" & 24" & 30")
- 29 Cover Bearing Housing O-Ring (20" & 24" & 30")
- 30 Hex Bolt (20" & 24")
- 31 Pipe Cap (20" & 24" & 30")

WHEN ORDERING PARTS, BE SURE TO GIVE COMPLETE NAMEPLATE DATA, ITEM NUMBER AND DESCRIPTION.

INSTALLATION AND MAINTENANCE INSTRUCTIONS

2-WAY INTERNAL PILOT OPERATED SOLENOID VALVES DIAPHRAGM TYPE - 3/8, 1/2 AND 3/4 N.P.T. NORMALLY CLOSED OPERATION

BULLETINS

8210

8211

ASCO

FORM NO. V-5848

DESCRIPTION

Bulletin 8210's are 2-way, normally closed internal pilot operated solenoid valves. Valve bodies and bonnets are of brass construction. Standard valves have a General Purpose, NEMA Type 1 Solenoid Enclosure. Bulletin 8211's are the same as Bulletin 8210's except the solenoids are equipped with an enclosure which is designed to meet NEMA Type 4, Watertight, NEMA Type 7 (C or D) Hazardous Locations - Class 1, Group C or D and NEMA Type 9 (E, For G) Hazardous Locations - Class 2, Groups E, F or G. The Explosion-Proof/Watertight Solenoid Enclosures are shown on separate sheets of installation and Maintenance Instructions, Form Numbers V-5380 and V-5391.

OPERATION

Normally Closed: Valve is closed when solenoid is de-energized and opens when solenoid is energized.

MANUAL OPERATOR (Optional)

Valves with Suffix 'MO' in the catalog number are provided with a manual operator which allows manual operation when desired or during an interruption of electrical power. To operate valve manually, push in knurled cap and rotate clockwise 180° Disengage manual operator by rotating knurled cap counterclockwise 180° before operating electrically.

MANUAL OPERATOR LOCATION (Refer to Figures 1 and 3)

Manual operator (when shipped from factory) will be located over the valve outlet. Manual operator may be relocated at 90° increments by rotating valve bonnet. Remove bonnet screws (4) and rotate valve bonnet with solenoid to desired position. Replace bonnet screws (4) and torque in a crisscross manner to 110 ± 10 inch pounds.

If valve is installed in the system and is operational, proceed in the following manner: **WARNING:** Depressurize valve and turn off electrical power supply.

1. Remove retaining cap or clip and slip the entire solenoid enclosure off the solenoid base sub-assembly. **CAUTION:** When metal retaining clip disengages, it will spring upwards.
2. Remove bonnet screws (4) and rotate valve bonnet to desired position.
3. Replace bonnet screws (4) and torque in a crisscross manner to 110 ± 10 inch pounds. Replace solenoid enclosure and retaining clip or cap.

INSTALLATION

Check nameplate for correct catalog number, pressure, voltage and service.

TEMPERATURE LIMITATIONS

For maximum valve ambient and fluid temperatures, refer to chart. The temperature limitations listed are for UL applications. For non-UL applications, higher ambient and fluid temperature limitations are available. Consult factory, Check catalog number on nameplate to determine maximum temperatures.

Construction	Coil Class	Catalog Number Prefix	Max. Ambient Temp.°F	Max. Fluid Temp.°F
A-C Construction (Alternating Current)	A	None or DA	77	180
	F	DF or FT	122	180
	H	HT	140	180
D-C Construction (Direct Current)	A, F or H	None, FT or HT	77	150

POSITIONING/MOUNTING

This valve is designed to perform properly when mounted in any position. However, for optimum life and performance, the solenoid should be mounted vertical and upright so as to reduce the possibility of foreign matter accumulating in the core tube area. For mounting bracket (optional feature) dimensions, refer to Figure 2.

PIPING

Connect piping to valve according to markings on valve body. Apply pipe compound sparingly to male pipe threads only; if applied to valve threads, it may enter the valve and cause operational difficulty. Pipe strain should be avoided by proper support and alignment of piping. When tightening the pipe, do not use valve as a lever, Wrenches applied to valve body or piping are to be located as close as possible to connection point.

IMPORTANT: For the protection of the solenoid valve, install a strainer or filter suitable for the service involved in the inlet side as close to the valve as possible. Periodic cleaning is required depending on the service conditions. See Bulletins 8600, 8601 and 8602 for strainers.

WIRING

Wiring must comply with Local and National Electrical Codes. Housings for all solenoids are provided with connections for 1/2 inch conduit. The general purpose solenoid enclosure may be rotated to facilitate wiring by removing the retaining cap or clip. **CAUTION:** When metal retaining clip disengages, it will spring upwards. Rotate to desired position. Replace retaining cap or clip before operating.

NOTE: Alternating Current (A-C) and Direct Current (D-C) solenoids are built differently. To convert from one to the other, It is necessary to change the complete solenoid including the solenoid base sub-assembly and core assembly.

SOLENOID TEMPERATURE

Standard catalog valves are supplied with coils designed for continuous duty service. When the solenoid is energized for a long period, the solenoid enclosure becomes hot and can be touched with the hand only for an instant. This is a safe operating temperature. Any excessive heating will be indicated by the smoke and odor of burning coil insulation.

MAINTENANCE

WARNING: Turn off electrical power supply and depressurize valve before making repairs. It is not necessary to remove the valve from the pipe line for repairs.

CLEANING

A periodic cleaning of all solenoid valves is desirable. The time between cleanings will vary, depending on media and service conditions. In general, if the voltage to the coil is correct, sluggish valve operation, excessive leakage or noise will indicate that cleaning is required.

PREVENTIVE MAINTENANCE

1. Keep the medium flowing through the valve as free from dirt and foreign material as possible.
2. While in service, operate the valve at least once a month to insure proper opening and closing.
3. Periodic inspection (depending on media and service conditions) of internal valve parts for damage or excessive wear is recommended. Thoroughly clean all parts, Replace any parts that are worn or damaged.

IMPROPER OPERATION

1. **Faulty Control Circuit:** Check the electrical system by energizing the solenoid. A metallic click signifies that the solenoid is operating. Absence of the click indicates loss of power supply. Check for loose or blown-out fuses, open circuited or grounded coil, broken lead wires or splice connections.
2. **Burned-Out Coil:** Check for open circuited coil. Replace coil if necessary.
3. **Low Voltage:** Check voltage across coil leads. Voltage must be at least 85% of nameplate rating.
4. **Incorrect Pressure:** Check valve pressure. Pressure to valve must be within range specified on nameplate.
5. **Excessive Leakage:** Disassemble valve and clean all parts. Replace worn or damaged parts with a complete Spare Parts Kit for best results.

COIL REPLACEMENT (Refer to Figures 1, 2 and 3)

Turn off electrical power supply and disconnect coil lead wires. Proceed in the following manner:

1. Remove retaining cap or clip, nameplate and cover. **CAUTION:** When metal retaining clip disengages, it will spring upwards.
2. Slip yoke containing coil, sleeves and insulating washers off the solenoid base sub-assembly. For D-C Construction, slip spring washer, coil and insulating washers off the solenoid base sub-assembly. Insulating washers are omitted when a molded coil is used.
3. Reassemble in reverse order of disassembly paying careful attention to exploded views provided for identification and placement of parts. **CAUTION:** Solenoid must be fully reassembled as the housing and internal parts are part of and complete the magnetic circuit. Place insulating washers at each end of con, if required.

VALVE DISASSEMBLY

Depressurize valve and turn off electrical power supply. For A-C Construction, refer to Figures 1 and 2. For D-C Construction, refer to Figure 3. Proceed in the following manner:

1. Disassemble valve in an orderly fashion. Pay careful attention to exploded views provided for identification of parts.
2. Remove retaining cap or clip and slip the entire solenoid enclosure off the solenoid base sub-assembly. **CAUTION:** When metal retaining clip disengages, it will spring upwards.
3. Unscrew solenoid base sub-assembly and remove bonnet gasket. Core assembly and core spring.
4. For A-C Construction without manual operator, remove valve bonnet screws (4). Remove solenoid base sub-assembly, core assembly and core spring.
5. Remove diaphragm spring (A-C Construction only), diaphragm assembly and body gasket.
6. For normal maintenance, it is not necessary to disassemble the manual operator unless external leakage is evident to disassemble, remove stem pin, manual operator stem, stem spring and stem gasket.
7. All parts are now accessible for cleaning or replacement. Replace worn or damaged parts with a complete Spare Parts Kit for best results.

VALVE REASSEMBLY

1. Reassemble in reverse order of disassembly paying careful attention to exploded views provided for identification and placement of parts.
2. Replace body gasket and diaphragm assembly. Locate bleed hole in diaphragm assembly approximately 45° from valve outlet.
3. Replace valve bonnet and bonnet screws. Torque bonnet screws (4) in a crisscross manner to 110 ± 10 inch pounds.
4. For A-C Construction, the diaphragm spring, core assembly and core spring must be installed prior to assembly of bonnet as this is the solenoid base sub-assembly. Be sure diaphragm spring is installed properly. Closed turns of spring to seat on diaphragm assembly. For valves with a manual operator (see Figure 1), the small end of diaphragm spring seats on diaphragm assembly.
5. Install core spring in core assembly. Be sure core spring is inserted into core assembly with wide end in first. Closed end protrudes from top of core assembly.
6. Replace bonnet gasket, core assembly, core spring and solenoid base sub-assembly. Torque solenoid base sub-assembly to 175 ± 25 inch pounds.
7. If removed, replace manual operator stem gasket, stem spring, stem and stem pin.
8. Replace solenoid enclosure and retaining cap or clip.
9. After maintenance, operate the valve a few times to be sure of proper opening and closing.

Spare Parts Kits

Spare Parts Kits and Coils are available for ASCO valves. Parts marked with an (*) are supplied in Spare Parts Kits

ORDERING INFORMATION FOR SPARE PARTS KITS

When Ordering Spare Parts Kits or Coils Specify Valve Catalog Number, Serial Number and Voltage

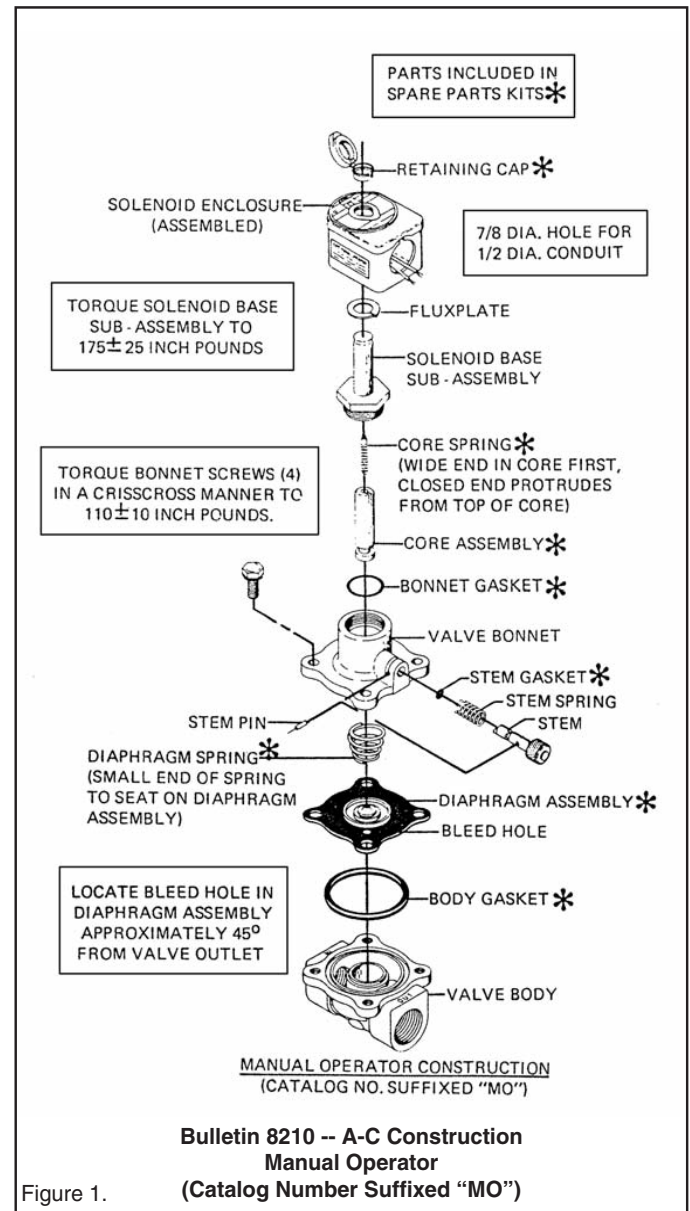

Figure 1.

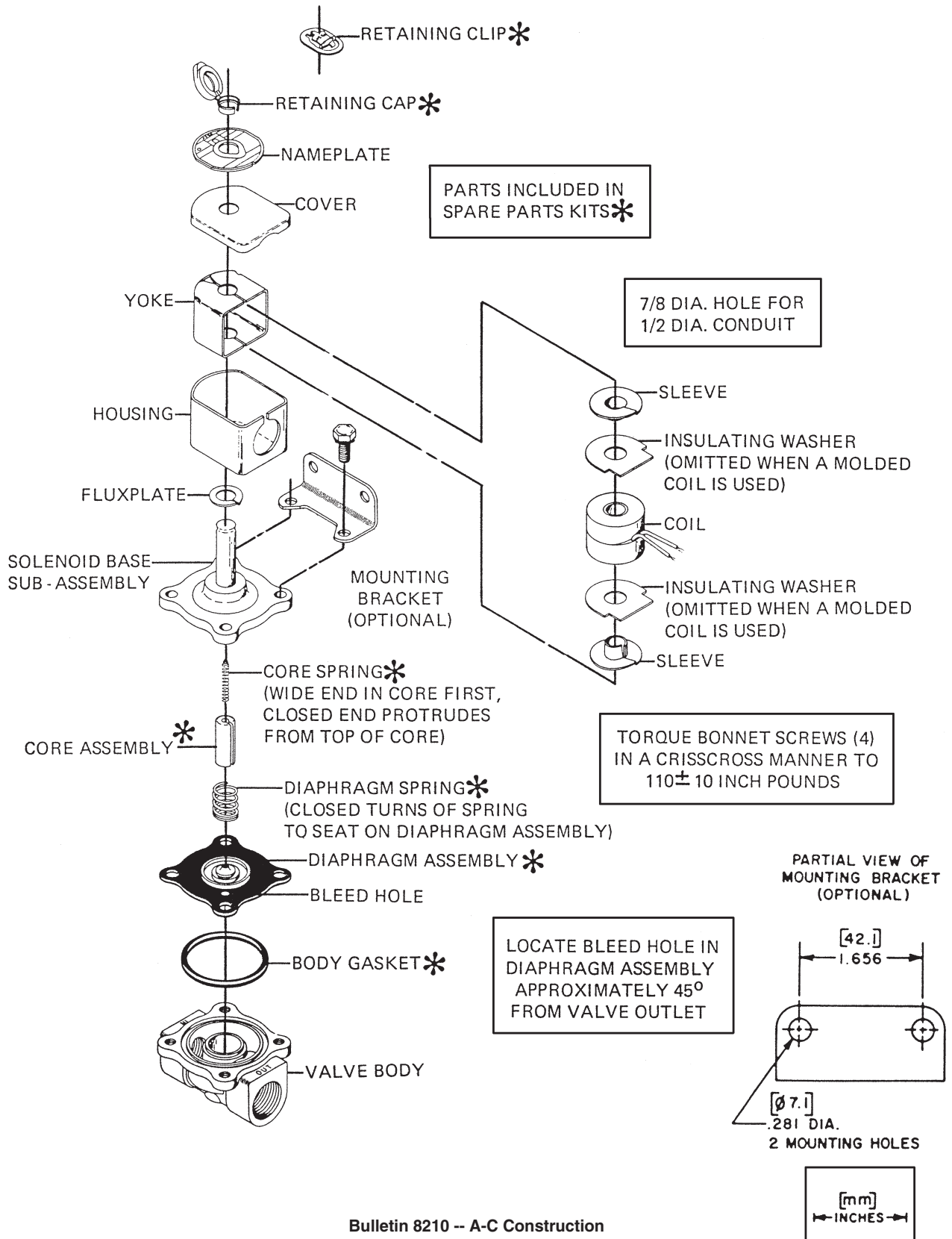

Figure 2. For Explosion-Proof/Watertight Solenoid Enclosure used on Bulletin 8211, see Form No. V-5391.

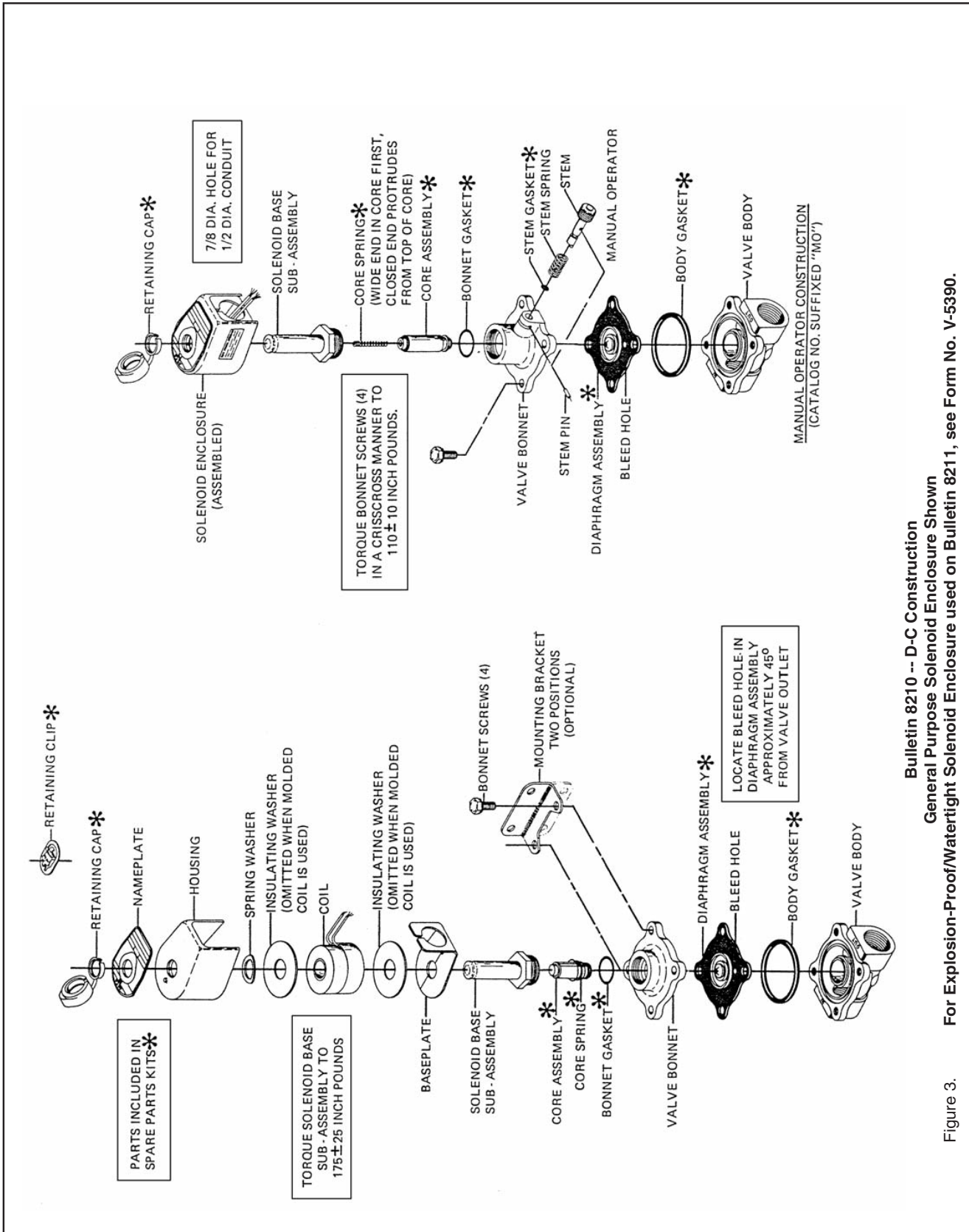

Figure 3. Bulletin 8210 -- D-C Construction
 General Purpose Solenoid Enclosure Shown
 For Explosion-Proof/Watertight Solenoid Enclosure used on Bulletin 8211, see Form No. V-5390.

INSTALLATION AND MAINTENANCE INSTRUCTIONS

2-WAY DIRECT ACTING SOLENOID VALVES NORMALLY CLOSED OPERATION -- 1/4 N.P.T.

BULLETINS
8262

ASCO
FORM NO. V-5927

DESCRIPTION

Bulletin 8262's are 2-way normally closed, direct acting solenoid valves having bodies of brass construction. Standard valves have a General Purpose NEMA Type 1 Solenoid Enclosure. Valves may also be equipped with a solenoid enclosure which is designed to meet NEMA Type 4 Watertight, NEMA Type 7 (C or D) Hazardous Locations-Class 1, Groups C or D and NEMA Type 9 (E, For G) Hazardous Locations Class 2, Groups E, F or G. Installation and Maintenance Instructions for Explosion-Proof/Watertight Solenoid Enclosures are shown on Form Nos. V-5391 or V-5380.

OPERATION

Normally Closed: Valve is closed when solenoid is de-energized. Valve opens when solenoid is energized.

NOTE: Inlet port will either be marked "1" or "1N." Outlet port will be marked "2."

IMPORTANT: No minimum operating pressure required.

INSTALLATION

Check nameplate for correct catalog number, pressure, voltage and service.

TEMPERATURE LIMITATIONS

For maximum valve ambient and fluid temperature, refer to chart below. For higher ambient and fluid temperatures, consult factory. Check catalog number and watt rating on nameplate to determine the maximum temperatures.

Wattage	Catalog Number Prefix	Coil Class	Max. Ambient Temp. °F	Max. Fluid Temp. °F
6	None	A	77	180
	FT	F	122	200
	HT	H	140	200
9	None	F	77	180
9.7	None, FT or HT	A, F or H	77	120
11.2*	None, FT or HT	A, F or H	77	150
16.7*	None	F	77	200

*Catalog Nos. 8262C200 and 8262B200 and valves with suffix "W" in the catalog number are limited to 140°F fluid temperature.

POSITIONING

Valve is designed to perform properly when mounted in any position. However, for optimum life and performance, the solenoid should be mounted vertical and upright so as to reduce the possibility of foreign matter accumulating in the core tube area.

MOUNTING

For valve body and mounting bracket mounting dimensions, refer to Figures 1 and 2.

PIPING

Connect piping according to markings on valve body. Apply pipe compound sparingly to male pipe threads only; if applied to valve threads, it may enter valve and cause operational difficulty. Pipe strain should be avoided by proper support and alignment of piping. When tightening the pipe, do not use valve as a lever. Wrenches applied to valve body or piping are to be located as close as possible to connection point.

IMPORTANT: For the protection of the solenoid valve, install a strainer or filter suitable for the service involved in the inlet side as close to the valve as possible. Periodic cleaning is required depending upon service conditions. See Bulletins 8600, 8601 and 8602 for strainers.

WIRING

Wiring must comply with Local and National Electrical Codes. Solenoid housings are provided with a 7/8 diameter hole for 1/2 inch conduit. The general purpose solenoid enclosure may be rotated to facilitate wiring by removing the retaining cap or clip. **CAUTION:** When metal retaining clip disengages, it will spring upward. Rotate enclosure to desired position. Replace retaining cap or clip before operating.

NOTE: Alternating Current (A-C) and Direct Current (D-C) solenoids are built differently. To convert from one to the other, it is necessary to change the complete solenoid including the core assembly and solenoid base sub-assembly.

SOLENOID TEMPERATURE

Standard catalog valves are supplied with coils designed for continuous duty service. When the solenoid is energized for a long period, the solenoid enclosure becomes hot and can be touched with the hand only for an instant. This is a safe operating temperature. Any excessive heating will be indicated by the smoke and odor of burning coil insulation.

MAINTENANCE

WARNING: Turn off electrical power supply and depressurize valve before making repairs. It is not necessary to remove the valve from the pipe line for repairs.

CLEANING

A periodic cleaning of all solenoid valves is desirable. The time between cleanings will vary depending upon media and service conditions in general, if the voltage to the coil is correct. Sluggish valve operation, excessive noise or leakage will indicate that cleaning is required. Clean valve strainer or filter when cleaning solenoid valve.

PREVENTIVE MAINTENANCE

1. Keep the medium flowing through the valve as free from dirt and foreign material as possible.
2. While in service, operate the valve at least once a month to insure proper opening and closing.
3. Periodic inspection (depending on media and service conditions) of internal valve parts for damage or excessive wear is recommended. Thoroughly clean all parts. Replace any parts that are worn or damaged.

IMPROPER OPERATION

1. **Faulty Control Circuit:** Check the electrical system by energizing the solenoid. A metallic click signifies the solenoid is operating. Absence of the click indicates loss of power supply. Check for loose or blownout fuses, open-circuited or grounded coil, broken lead wires or splice connections.
2. **Burned-Out Coil:** Check for open-circuited coil. Replace coil if necessary.
3. **Low Voltage:** Check voltage across the coil leads. Voltage must be at least 85% of nameplate rating.
4. **Incorrect Pressure:** Check valve pressure. Pressure to valve must be within range specified on nameplate.
5. **Excessive Leakage:** Disassemble valve and clean all parts. Replace worn or damaged parts with a complete Spare Parts Kit for best results.

COIL REPLACEMENT

Turn off electrical power supply and disconnect coil lead wires. Refer to watt rating stamped on nameplate for identification of solenoid construction. When you have determined the watt rating of solenoid, select the correct paragraph below.

FIGURE 3 SHOWS A SOLENOID WITH A WATT RATING OF 6 A.C., 9.7 D.C. OR 9 A.C.

1. Remove retaining cap or clip, nameplate and cover. **CAUTION:** When metal retaining clip disengages, it will spring upward.
2. Slip the yoke containing a coil, sleeves and insulating washers off the solenoid base sub-assembly. Insulating washers are omitted when a molded coil is used.
3. Slip coil, sleeves and insulating washers from yoke. 4. Reassemble in reverse order of disassembly paying careful attention to exploded view provided for identification and placement of parts.

FIGURE 4 SHOWS A SOLENOID WITH A WATT RATING OF 105 A-C, 11.2 D-C OR 16.7 A-C

1. Remove retaining cap or clip, nameplate and housing. **CAUTION:** When metal retaining clip disengages, it will spring upward.
 2. Slip spring washer, insulating washer and coil off the solenoid base sub-assembly. Insulating washers are omitted when a molded coil is used.
 3. Reassemble in reverse order of disassembly paying careful attention to exploded views provided for identification and placement of parts.
- CAUTION:** Solenoid must be fully reassembled as the housing and internal parts are part of and complete the magnetic circuit. Place an insulating washer at each end of coil, if required.

VALVE DISASSEMBLY AND REASSEMBLY

Depressurize valve and turn off electrical power supply. For valves with a watt rating of 6 A-C, 9.7 D-C or 9 A-C, refer to Figure 3. For valves with a watt rating of 10.5 A-C, 11.2 D-C or 16.7 A-C, refer to Figure 4.

Proceed in the following manner:

1. Remove retaining cap or clip and slip the entire solenoid enclosure off the solenoid base sub-assembly. **CAUTION:** When metal retaining clip disengages, it will spring upward.
2. Unscrew solenoid base sub-assembly and remove core assembly, core spring and body gasket.
3. All parts are now accessible for cleaning or replacement. Replace worn or damaged parts with a complete Spare Parts Kit for best results.
4. Reassemble in reverse order of disassembly paying careful attention to exploded views provided for identification and placement of pans.
5. Replace body gasket, core assembly, core spring and solenoid base sub-assembly. Torque solenoid base sub-assembly to 175 ± 25 inch pounds.
6. After maintenance, operate the valve a few times to be sure of proper operation.

SPARE PARTS KITS

Spare Parts Kits and Coils are available for ASCO valves. Parts marked with an asterisk (*) are supplied in Spare Parts Kit.

ORDERING INFORMATION FOR SPARE PARTS KITS

When Ordering Spare Parts Kits or Coils, Specify Valve Catalog Number, Serial Number and Voltage.

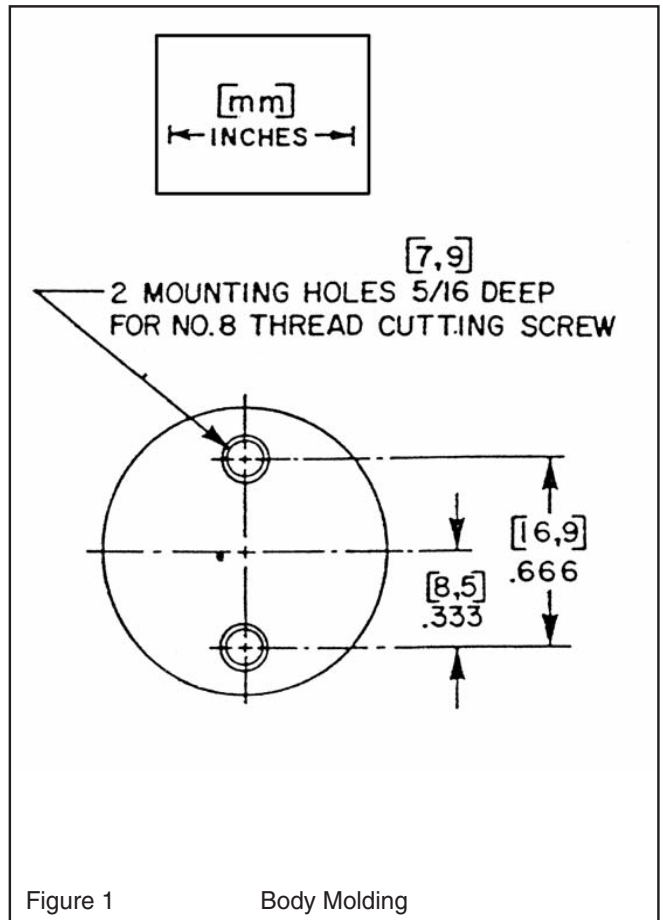

Figure 1 Body Molding

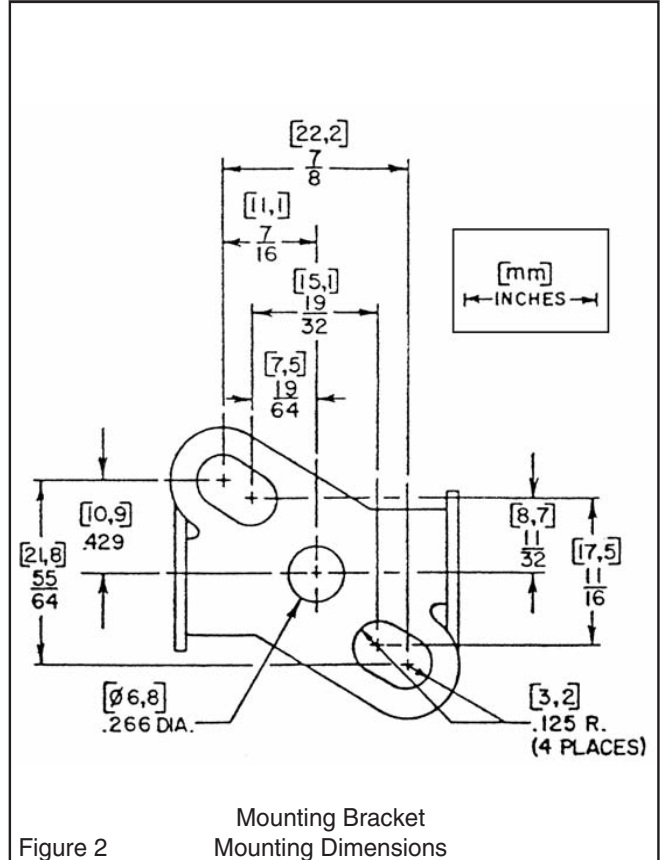
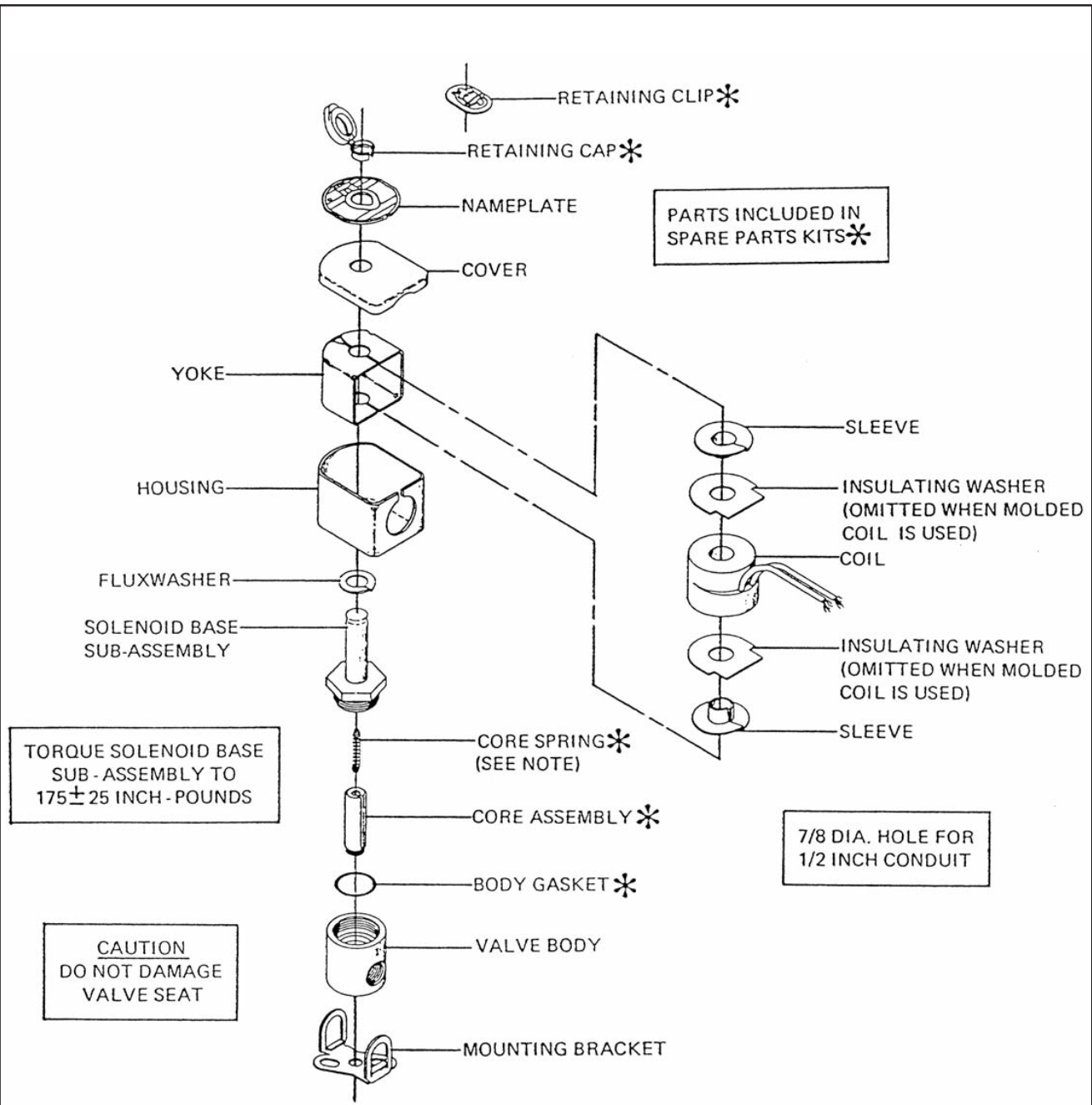

Figure 2 Mounting Bracket Mounting Dimensions



NOTE: A-C (ALTERNATING CURRENT) CONSTRUCTION SHOWN. FOR A-C CONSTRUCTION, EITHER END OF THE SPRING MAY BE INSTALLED INTO TOP OF CORE ASSEMBLY. FOR D-C (DIRECT CURRENT) CONSTRUCTION, INSTALL WIDE END OF CORE SPRING IN CORE ASSEMBLY FIRST, CLOSED END OF CORE SPRING PROTRUDES FROM TOP OF CORE ASSEMBLY.

Bulletin 8262 (6 A-C, 9.7 D-C or 9 Watts A-C)
 General Purpose Solenoid Enclosure Shown

Figure 3

For Explosion-Proof/Watertight Solenoid Enclosure, See Form No. V-5391

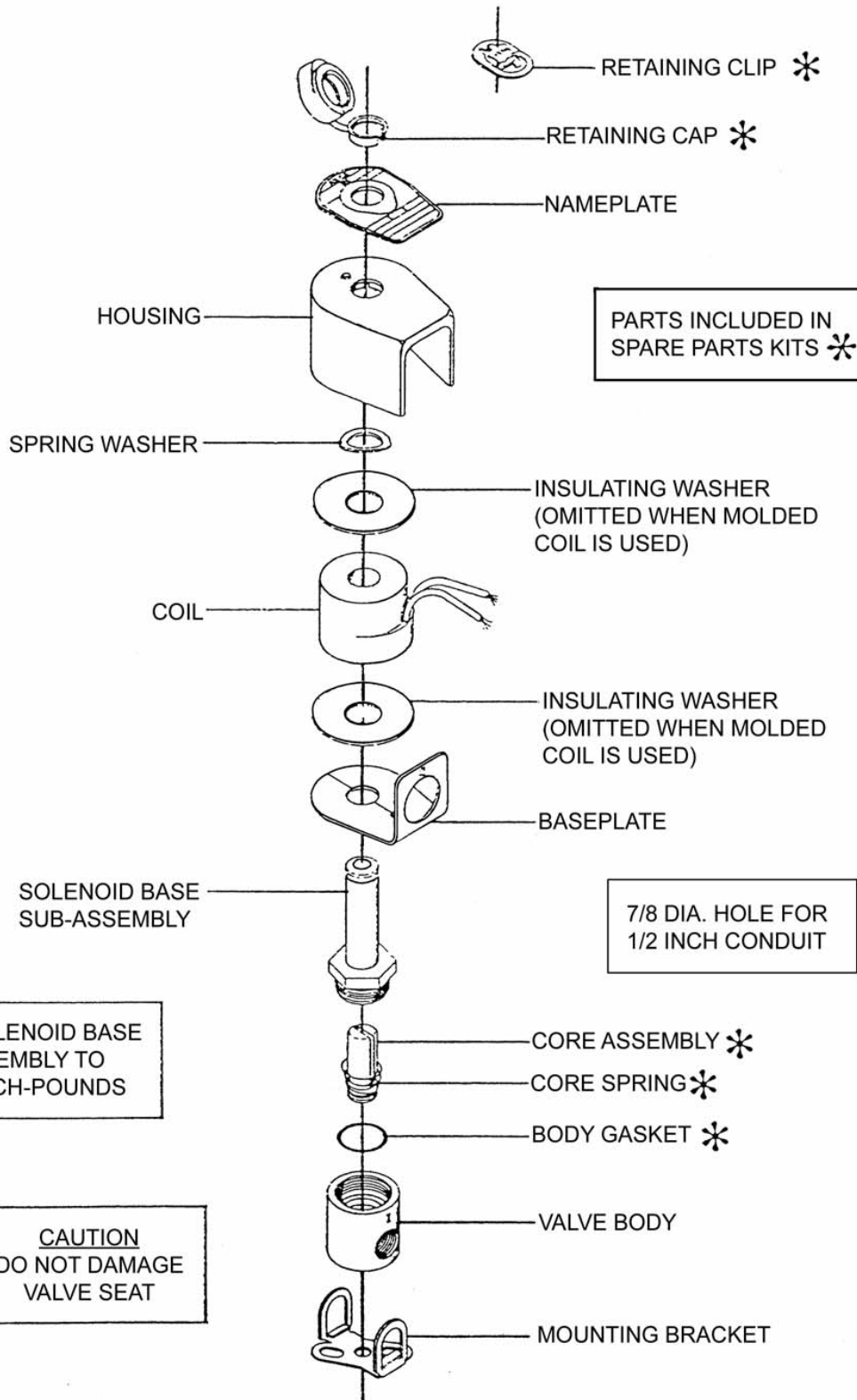

Bulletin 8262 (10.5 A-C, 11.2 D-C or 16.7 Watts A-C)

General Purpose Solenoid Enclosure Shown

For Explosion-Proof/Watertight Solenoid Enclosure, See Form No. V-5380

Figure 3

AK	07-10-08	BB	ADDED PN'S 67783-62B (NED 62200)
AK	08-14-08	BC	ADDED PN'S 67783-63K (NED 62218)
PC	10-1-2008	BD	ADDED PN 67783-64H (NED 62446)
CAD REVISION RECORD - DO NOT REVISE MANUALLY		BY	DATE
LTR	DESCRIPTION		
A-AY	SEE REVISION FILE		
BA	ADDED PN'S 67783-59H, 67783-60F & 67783-61D (ECO 20434)	AK	03-14-06

 CLA-VAL CO. NEWPORT BEACH, CALIFORNIA	CATALOG NO.	DRAWING NO.	REV
		67783	BD
TYPE OF VALVE AND MAIN FEATURES		DESIGN	
<p style="text-align: center; font-size: 24pt;">CK2 COCK/BALL VALVE</p>		DRAWN	MGR 4-02-80
		CHK'D	KD 4-03-80
		APV'D	CH 4-07-80

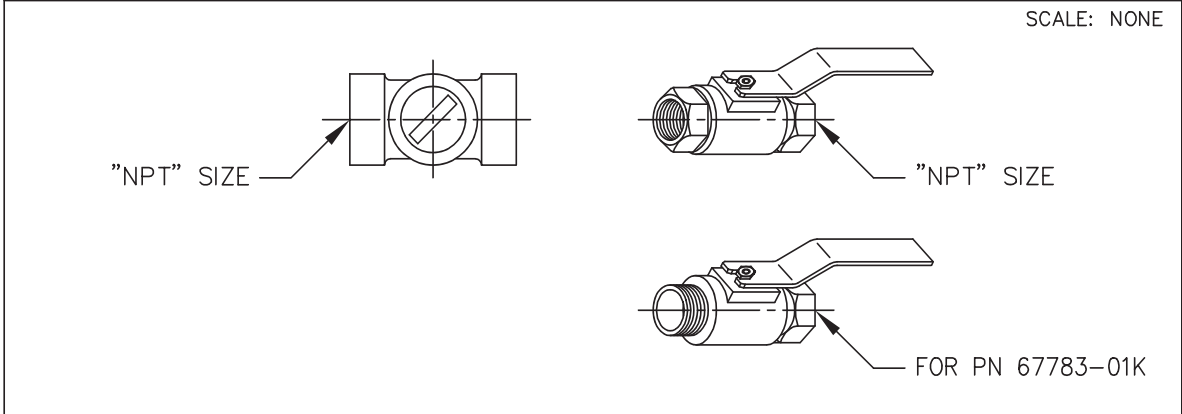

CLA-VAL PART NO. AND MATERIAL								
BRONZE WITH HANDLE	STEEL WITH HANDLE	IRON WITH HANDLE	316 SST WITH HANDLE	316 SST W/ LOCKING HANDLE	BRONZE WITH HANDLE	MONEL WITH HANDLE	MONEL W/ LOCKING HANDLE	SIZE "NPT"
67783-01K*	-09C	-17F	-25J SUPSD BY-26G		-41F SUPSD BY-01K			1/8"
-02H	-10A	-18D	-26G	-51E SUPSD BY-26G -52C	-42D SUPSD BY-02H	-55F		1/4"
-03F * -59H***	-11J	-19B	-27E	-46E SUPSD BY-27E -53A	-45G -57B * *	-48A SUPSD BY-49J	-63K	3/8"
-04D -60F ***	-12G	-20K	-28C	-54J	-43B SUPSD BY-04D	-49J	-62B	1/2"
-05A -61D ***	-13E	-21H	-29A	-64H	-44K SUPSD BY-05A	-56D		3/4"
-06J	-14C	-22F	-30J			-58K		1"
-07G	-15K	-23D	-31G					1 1/4"
-08E	-16H	-24B	-32E					1 1/2"
-50G			-47C					2"

- * SEE ENGINEERING APPROVED VENDORS TABLE (SHEET 2 OF 2).
- ** HAMMOND VALVE 8501 ONLY.
- *** WILKINS CK2 (SEE SHEET 2 OF 2)

"THIS DRAWING IS THE PROPERTY OF CLA-VAL CO. AND SAME AND COPIES MADE THEREOF, IF ANY, SHALL BE RETURNED TO IT UPON DEMAND. DELIVERY AND DISCLOSURE HEREOF ARE SOLELY UPON CONDITION THAT THE SAME SHALL NOT BE USED, COPIED OR REPRODUCED, NOR SHALL THE SUBJECT HEREOF BE DISCLOSED IN ANY MANNER TO ANYONE FOR ANY PURPOSE, EXCEPT AS HEREIN AUTHORIZED, WITHOUT PRIOR WRITTEN APPROVAL OF CLA-VAL CO. THIS DRAWING IS SUBMITTED CONFIDENTIALLY AND MAY NOT BE USED IN THE MANUFACTURE OF ANY MATERIAL OR PRODUCT OTHER THAN SUCH MATERIALS AND PRODUCTS FURNISHED TO CLA-VAL CO. WHETHER OR NOT THE EQUIPMENT OR INFORMATION SHOWN HEREON IS PATENTED OR OTHERWISE PROTECTED, FULL TITLE AND COPYRIGHTS, IF ANY, IN AND TO THIS DRAWING AND/OR INFORMATION DELIVERED OR SUBMITTED ARE FULLY RESERVED CLA-VAL CO."



Model X46

PRESSURE REDUCING CONTROL

- Self Scrubbing Cleaning Action
- Straight Type or Angle Type

The Cla-Val Model X46 Strainer is designed to prevent passage of foreign particles larger than 0.015". It is especially effective against such contaminant as algae, mud, scale, wood pulp, moss, and root fibers. There is a model for every Cla-Val valve.

The X46 Flow Clean strainer operates on a velocity principle utilizing the circular "air foil" section to make it self cleaning. Impingement of particles is on the "leading edge" only. The low pressure area on the downstream side of the screen prevents foreign particles from clogging the screen. There is also a scouring action, due to eddy currents, which keeps most of the screen area clean.

INSTALLATION

The strainer is designed for use in conjunction with a Cla-Val Main Valve, but can be installed in any piping system where there is a moving fluid stream to keep it clean. When it is used with the Cla-Val Valve, it is threaded into the upstream body port provided for it on the side of the valve. It projects through the side of the Main Valve into the flow stream. All liquid shunted to the pilot control system and to the cover chamber of the Main Valve passes through the Model X46 Flow Clean Strainer.

INSPECTION

Inspect internal and external threads for damage or evidence of cross-threading. Check inner and outer screens for clogging, embedded foreign particles, breaks, cracks, corrosion, fatigue, and other signs of damage.

DISASSEMBLY

Do not attempt to remove the screens from the strainer housing.

CLEANING

After inspection, cleaning of the Model X46 can begin. Water service usually will produce mineral or lime deposits on metal parts in contact with water. These deposits can be cleaned by dipping Model X46 in a 5-percent muriatic acid solution just long enough for deposit to dissolve. This will remove most of the common types of deposits.

CAUTION: use extreme care when handling acid. If the deposit is not removed by acid, then a fine grit (400) wet or dry sandpaper can be used with water. Rinse parts in water before handling. An appropriate solvent can clean parts used in fueling service. Dry with compressed air or a clean, lint-free cloth.

Protect from damage and dust until reassembled.

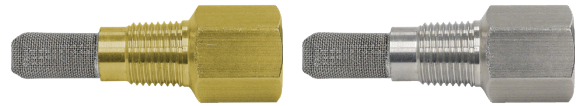

Model X46A Straight

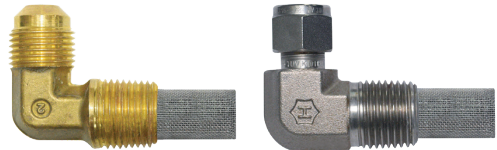

Model X46B Angle

REPLACEMENT

If there is any sign of damage, or if there is the slightest doubt that the Model X46 Flow Clean Strainer may not afford completely satisfactory operation, replace it. Use Inspection steps as a guide. Neither inner screen, outer screen, nor housing is furnished as a replacement part. Replace Model X46 Flow Clean Strainer as a complete unit.

When ordering replacement Flow-Clean Strainers, it is important to determine pipe size of the tapped hole into which the strainer will be inserted (refer to column A or F), and the size of the external connection (refer to column B or G).



Dimensions (in Inches)

X46 Straight Type A (In Inches)						
A (NPT)	C (NPT)	D	E	F	G	I
1/8	1/8	1-3/4	3/4	1/2	1/2	1/4
1/4	1/4	2-1/4	1	3/4	3/4	3/8
3/8	3/8	2-1/2	1	7/8	7/8	1/2
3/8	1/2	2-1/2	1-1/4	1/2	7/8	3/4
1/2	1/2	3	1-1/4	1	1-1/8	3/4
3/8	3/4	3-3/8	2	1/2	1	7/8
3/4	3/4	4	2	1	1-1/2	7/8
3/8	1	4-1/4	2-3/4	1/2	1-3/8	7/8
1	1	4-1/2	2-3/4	1-1/4	1-3/4	7/8
1/2	1	4-1/4	2-3/4	1/2	1-3/8	7/8

X46 Angle Type B (In Inches)					
B (NPT)	C (SAE)	D	E	H	I
1/8	1/4	1-3/8	5/8	7/8	1/4
1/4	1/4	1-3/4	3/4	1	3/8
3/8	1/4	2	7/8	1	1/2
3/8	3/8	1-7/8	7/8	1	1/2
1/2	3/8	2-3/8	1	1-1/4	5/8

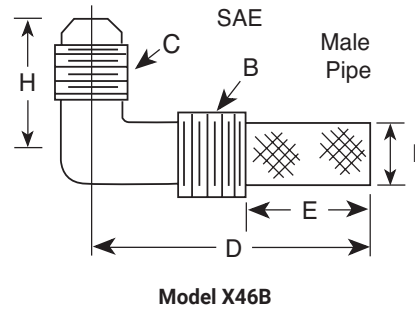
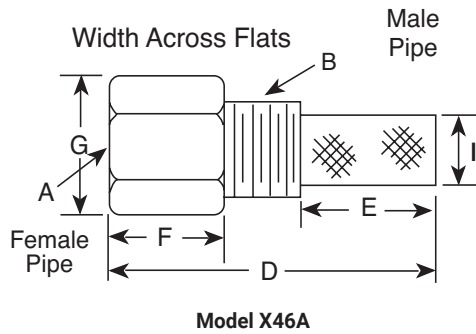

When Ordering, Please Specify

1. Catalog number X46
2. Straight or Angel Type
3. Size inserted into and size connection
4. Materials





Model CV FLOW CONTROL

DESCRIPTION

The CV Control is an adjustable restriction which acts as a needle valve when flow is in the direction of the stem. When flow is in the reverse direction, the port area opens fully to allow unrestricted flow. When installed in the control system of a Cla-Val automatic valve, it can be arranged to function as either an opening or closing speed control.

OPERATION

The CV Flow Control permits full flow from port A to B, and restricted flow in the reverse direction. Flow from port A to B lifts the disc from seat, permitting full flow. Flow in the reverse direction seats the disc, causing fluid to pass through the clearance between the stem and the disc. This clearance can be increased, thereby increasing the restricted flow, by screwing the stem out, or counter-clockwise. Turning the stem in, or clockwise reduces the clearance between the stem and the disc, thereby reducing the restricted flow.

INSTALLATION

Install the CV Flow Control as shown in the valve schematic. All connections must be tight to prevent leakage.

DISASSEMBLY

Follow the sequence of the item numbers assigned to the parts in the cross sectional illustration for recommended order of disassembly.

Use a scribe, or similar sharp-pointed tool to remove O-ring from the stem.

INSPECTION

Inspect all threads for damage or evidence of cross-threading. Check mating surface of seat and valve disc for excessive scoring or embedded foreign particles. Check spring for visible distortion, cracks and breaks. Inspect all parts for damage, corrosion and cleanliness.

CLEANING

After disassembly and inspection, cleaning of the parts can begin. Water service usually will produce mineral or lime deposits on metal parts in contact with water. These deposits can be cleaned by dipping the parts in a 5-percent muriatic acid solution just long enough for deposits to dissolve. This will remove most of the common types of deposits. **CAUTION: Use extreme care when handling acid.** If the deposit is not removed by acid, then a fine grit (400) wet or dry sandpaper can be used with water. Rinse parts in water before handling. An appropriate solvent can clean parts used in fueling service. Dry with compressed air or a clean, lint-free cloth. Protect from damage and dust until reassembled.

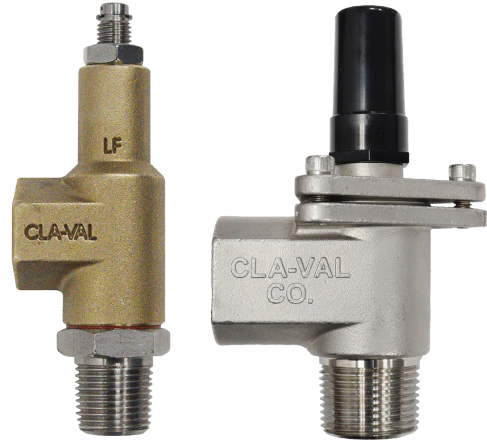

REPAIR AND REPLACEMENT

Minor nicks and scratches may be polished out using a fine grade of emery or crocus cloth; replace parts if scratches cannot be removed.

Replace O-ring packing and gasket each time CV Flow Control is overhauled.

Replace all parts which are defective. Replace any parts which create the slightest doubt that they will not afford completely satisfactory operation. Use Inspection steps as a guide.

REASSEMBLY

Reassembly is the reverse of disassembly; no special tools are required.

TEST PROCEDURE

No testing of the flow Control is required prior to reassembly to the pilot control system on Cla-Val Main Valve.





3/8" CV Flow Control

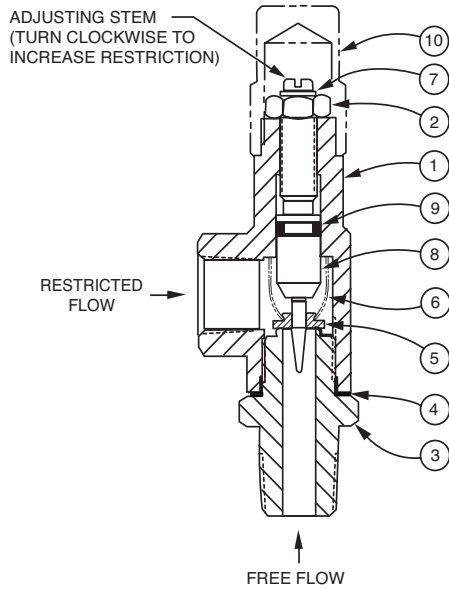

Item No.	Description	QTY
1	Housing	1
2	Nut, Jam	1
3	Seat	1
4	Gasket	1
5	Disc	1
6	Spring	1
7	Ring, Retaining	1
8	Stem	1
9	O-Ring	1
10	Cap (SS only)	1

1/2", 3/4", and 1" CV Flow Control

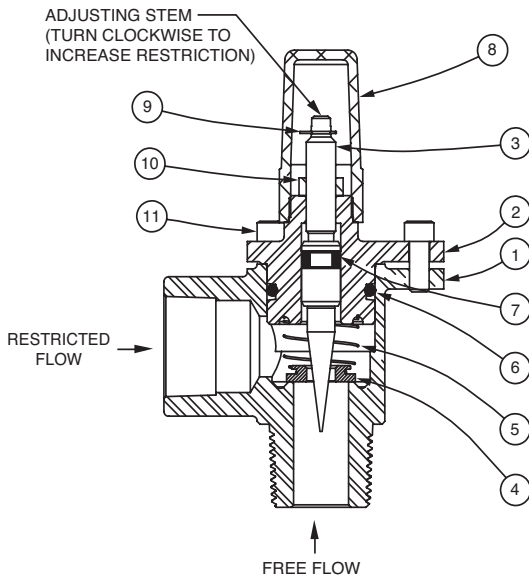

Item No.	Description	QTY
1	Body	1
2	Cover	1
3	Stem	1
4	Disc	1
5	Spring	1
6	O-Ring	1
7	O-Ring	1
8	Cap	1
9	Ring, Retaining	1
10	Nut, Jam	1
11	Socket Head Cap Screw	3

When Ordering, Please Specify

1. All Nameplate/Stamped data
2. Item Number
3. Description
4. Material





— MODEL — **CDC-1**
Check Valve
 Sizes 3/8", 1/2", 3/4" and 1"



- Meets Low Lead Requirements
- Patented Seal Design Allows for Drip Tight Shut-off at Low DP
- No Spring Required due to Patented Seal Design
- Delrin® Disc with Flow Profile Designed to Minimize Head Loss
- Delrin® Disc Resists Corrosion and/or Mineral Build-up
- Drip Tight Seating at both Low and High Operating Pressures
- Temperature Range: 10°F to 210°F
- EPR, NBR and Fluorocarbon Seal Options

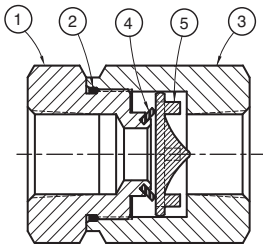

CDC-1 - 3/8" and 1/2"		
Item	Description	Quantity
1	Retainer, Seal	1
*2	O-Ring	1
3	Retainer, Valve	1
*4	Seal, Valve Ring	1
*5	Plate, Valve	1

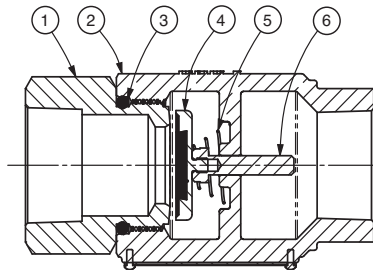

CDC-1 - 3/4" and 1"		
Item	Description	Quantity
1	Seat, Valve	1
2	Body, Valve	1
*3	O-Ring	1
*4	Disc Retainer Assembly	1
*5	Spring	1
*6	Stem, Valve	1

* Included in Repair Kit

Dimensions

Size (NPT)	A	B	C
3/8"	2.06	1.06	0.38 (3/8) - 18.0 NPT
1/2"	2.12	1.38	0.50 (1/2) - 14.0 NPT
3/4"	4.06	2.26	0.75 (3/4) - 14.0 NPT
1"	4.06	2.19	1.00 (1) - 11.5 NPT

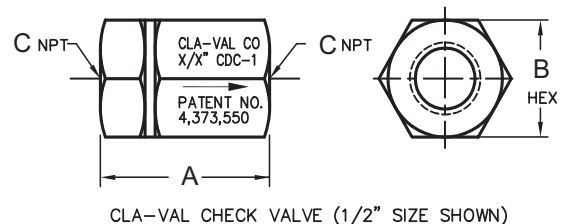



Model X117D

HYDRAULIC-OPERATED FLOW LIMITER

DESCRIPTION

The Cla-Val Model X117D Valve Position Transmitter is designed to provide analog signal (4 - 20 mA, 2 wire) output of valve position for Cla-Val Main Valves. A stem extension is fitted to the main valve stem with the position transmitter mechanically linked to it. The valve stem is mechanically linked to the electronics for an output signal that is in direct proportion to valve position. Provisions are made for bleeding air from valve cover through a small bleed screw and washer located on adapter.

OPERATION

The signal from the position sensing linkage mechanism is converted to a two-wire 4 to 20 mA current output appearing at the output terminals. The excitation voltage ranges from 12 to 35 Volts DC. The minimum supply voltage is a function of total loop resistance. It may be calculated using the formula:

$$V(\text{min}) = (0.02 \times \text{Load Resistance}) + 12 \text{ VDC}$$

INSTALLATION

Normally, the Model X117D is supplied mounted on the Cla-Val main valve. If X117D has not been installed at factory, then install stem, adapter, mounting bracket with transmitter (in that order) as shown on drawing No. 200000.

WIRING

Loosen jam nut holding transmitter and bracket to adapter when connecting transmitter to field wiring. Tighten jam nut after connections and adjustments are made.

Use good field wiring practices for low voltage DC analog instrumentation wiring (suggest minimum of 18-gauge multistrand wire). Avoid potential ground loops. Calibration of transmitter should be done with a temporary hookup of test equipment before final wiring connections are made.

Units with NEMA 6, IP-68 enclosures have permanently attached 8' shielded cable leads. Use Red wire for positive and Black wire for negative.

Units before Feb. 2000 have NEMA 6 enclosure with MS3102E-14S-6PAmphenol plug and socket for attaching leads. Use "A" contact for positive and "B" contact for negative.

For best noise immunity, use twisted pair shielded cable to connect field wiring to the transmitter. The shield of the cable should be open at the transducer and grounded at the other end. Units with permanently attached cable are supplied with shield open inside transmitter.

CALIBRATION

1. When properly adjusted, the transmitter will have the valve closed position within 0% to 30% of total transmitter range and the valve open position within 80% to 100% of total transmitter range. At valve closed position the transmitter will have a 4 mA output and at fully open position the transmitter will have a 20 mA output.

IMPORTANT CAUTION: The transmitter wire rope mechanism is spring loaded to retract and can be damaged by a sudden release of



the wire rope. Use care to ensure that it is returned to the transmitter very slowly during start up and operation. This damage may not be covered by warranty.

2. You will need the following tools to calibrate and align the Model X117D:

- A.) A small flat blade screwdriver (0.105 Max. width x 0.023" thickness) with non-metallic handle to fit the span and null potentiometer
- B.) A 4-20 mA calibration/tester or multiamp-tester/meter or some means of measuring the 4-20 mA transmitter output
- C.) Hand tools to adjust and tighten Model X117D assembly during calibration

3. Preliminary mechanical settings. (Refer to Drawing No. 200000) Be sure that the valve is in the fully closed position. See Technical Manual for the main valve for information on this. Check that line isolation or block valves are closed.

Adjust Nut Coupler (9) up or down on stem until gap between wire rope end and transmitter housing is according to table (below). The Hex Coupler (10) is used to tighten nut coupler to stem. A minimum gap is required, see Reference Table. (Refer to Drawing No. 200000)

Long threaded end of Hex Coupler (10) has two hex nuts (11) for adjusting position of end of wire rope directly over the opening in the top of the transmitter. Use one hex nut on each side of the wire rope end. Wire rope should go vertically up and down without noticeable angle from vertical.

4. Temporarily connect calibration equipment (milliamp meter and power supply or portable instrumentation tester) to transmitter wiring. Calculate total loop resistance to determine minimum load resistor. **See OPERATION section.** Remove two calibration cover screws found on housing end.

Refer to calibration equipment and adjust transmitter potentiometer marked "NULL" until the meter reads 4 mA. A clockwise turn increases output. Use care in adjusting the potentiometer while turning the screwdriver.



5. For the most accurate calibration it is necessary to open valve fully. **CAUTION:** This will either allow a high flow rate through the valve, or the downstream pressure will quickly increase to the inlet pressure. In some cases, this can be very harmful. Where this is the case, and there are no block valves in the system to protect the downstream piping, it should be realized that steps should be taken to remedy this situation before proceeding further. Normally, block valves are to be used to protect downstream piping while the valve is in the open position. Close downstream block valve. Vent cover chamber to atmosphere. Slightly open inlet block valve. Allow valve to open while fluid is vented from cover chamber. When flow stops valve is in the fully open position. Note: continuous leakage from cover chamber could mean additional troubleshooting of the main valve or pilot system must be done.

6. With valve in fully open position, inspect position of wire rope and nut coupler. (See Step 3). Adjust if necessary.

Refer to calibration equipment (see Step 4) and adjust potentiometer marked "SPAN" until the meter reads 20 mA. A clockwise turn increases output. Use care in adjusting the potentiometer while turning the screwdriver.

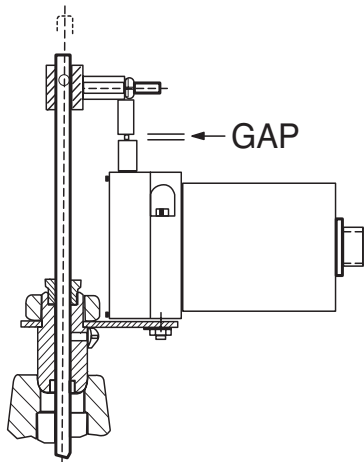

Coupler gap is set with valve in fully closed position. This establishes the minimum mechanical position for 4 mA output.

ADJUSTMENT: Zero and span adjustments allow setting the 4 mA position (valve closed) within 0% to 30% of total transmitter range and setting the 20 mA position (valve fully open) within 80% to 100% of total transmitter range.

7. There is some interplay between:
- A.) The "span" and "null" settings,
 - B.) The 4 to 20 mA signal and,
 - C.) The actual valve open and closed positions.
- Repeat steps 4-6 above. Cycle valve from open to closed positions and check settings as necessary to achieve desired valve position signal accuracy.

8. Remove all calibration equipment and attach permanent wiring. Recheck wiring and output signals at remote location. **See WIRING section.** Reinstall two cover screws on housing. Recheck and tighten all fasteners. Bleed air from main valve cover through small bleed screw and washer located on one wrench flat of adapter.

MAINTENANCE

The X117D is constructed of durable materials which normally requiring no lubrication or periodic maintenance. The two 'O' rings (2) (p/n 00951E) in the adapter (5) that seal against the stainless steel actuating stem (1) will need replacement if signs of leakage at the stem occur.

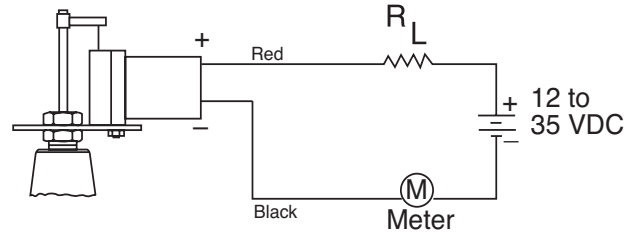

X117D Adjustment Parameters

Valve Size			Valve Stem Travel			Transmitter 4-20 mA				
100-01	100-20		Minimum "GAP"	Null and Span (in)		Travel Range (in)				
				0-30%	80-100%	Min.	Max.			
1 1/4	0	0.490	3/16	0.24	0.64	0.40	0.80			
1 1/2	0	0.490	3/16	0.24	0.64	0.40	0.80			
2	3	0.590	1/8	0.24	0.64	0.40	0.80			
2 1/2	0	0.714	3/16	0.29	0.78	0.49	0.98			
3	4	0.835	1/8	0.29	0.78	0.49	0.98			
4	6	1.091	9/16	0.60	1.60	1.00	2.00			
6	8	1.584	5/16	0.60	1.60	1.00	2.00			
8	10	2.242	1/2	0.90	2.40	1.50	3.00			
10	12	2.711	7/8	1.20	3.20	2.00	4.00			
12	14, 16	3.343	1/2	1.20	3.20	2.00	4.00			
14	0	4.084	11/16	1.50	4.00	2.50	5.00			
16	18, 20, 24	4.584	3/16	1.50	4.00	2.50	5.00			
18	0	5.125	2 15/16	3.00	8.00	5.00	10.00			
20	0	5.632	2 11/16	3.00	8.00	5.00	10.00			
24	30	6.500	2 1/4	3.00	8.00	5.00	10.00			
30	36	8.000	1 1/2	3.00	8.00	5.00	10.00			
36	42, 48	8.706	1 1/8	3.00	8.00	5.00	10.00			

Operating Zone

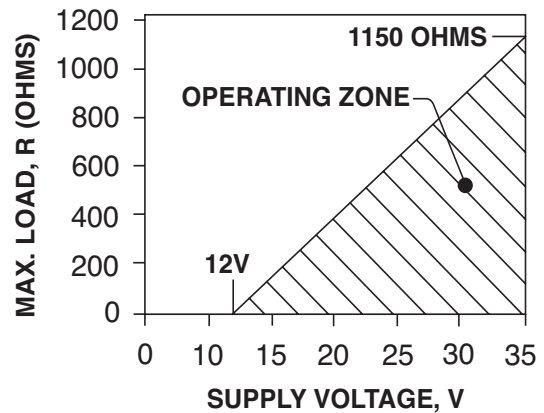



X43 Strainer

ITEM	DESCRIPTION	MATERIAL
1	Pipe Plug	Stainless Steel
2	Strainer Plug	Stainless Steel
3	Gasket	Fiber
4	Screen	Stainless Steel
5	Body	Stainless Steel
No parts available. Replacement assembly only.		

Standard 60 mesh pilot system strainer for fluid service.

Size	Stock Number
3/8 x 3/8	8850604D

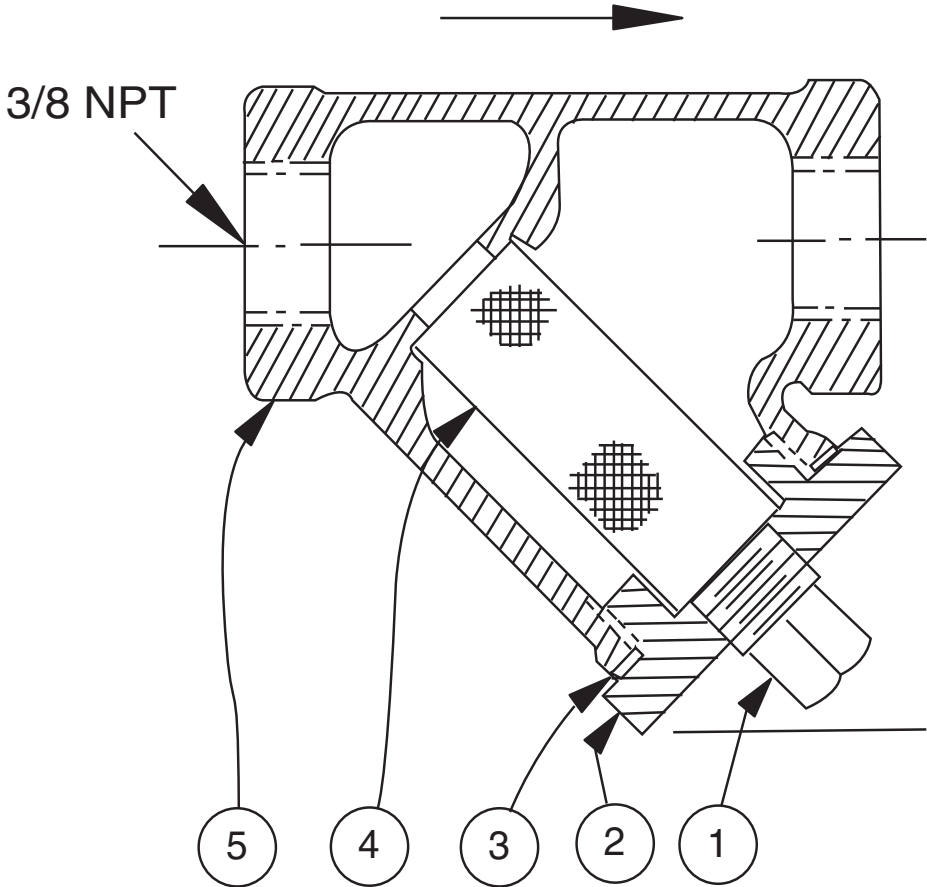



Cla-Val Product ID

HOW TO ORDER

PROPER IDENTIFICATION

For ordering repair kits, replacement parts, or for inquiries concerning valve operation, it is important to properly identify Cla-Val products already in service by including all nameplate data with your inquiry. Pertinent product data includes valve function, size, material, pressure rating, end details, type of pilot controls used and control adjustment ranges.

IDENTIFICATION PLATES

For product identification, cast-in body markings are supplemented by identification plates as illustrated on this page. The plates, depending on type and size of product, are mounted in the most practical position. **It is extremely important that these identification plates are not painted over, removed, or in any other way rendered illegible.**

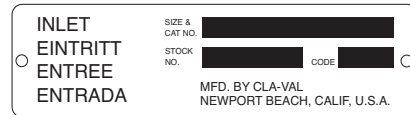

This brass plate appears on valves sized 2 1/2" and larger and is located on the top of the inlet flange.

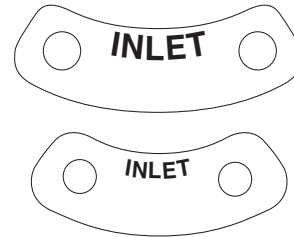

These two brass plates appear on 3/8", 1/2", and 3/4" size valves and are located on the valve cover.



This brass plate appears on altitude valves only and is found on top of the outlet flange.

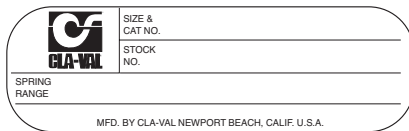

This tag is affixed to the cover of the pilot control valve. The adjustment range appears in the spring range section.

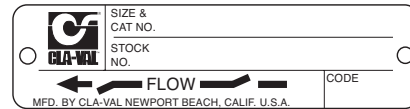

These two brass plates appear on threaded valves 1" through 3" size or flanged valves 1" through 2". It is located on only one side of the valve body.

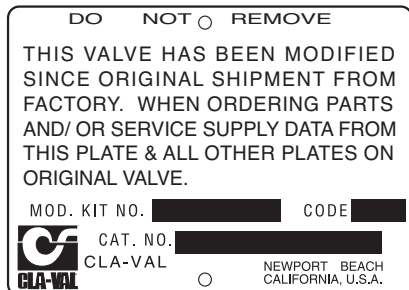

This aluminum plate is included in pilot system modification kits and is to be wired to the new pilot control system after installation.

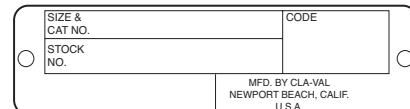

This brass plate is used to identify pilot control valves. The adjustment range is stamped into the plate.

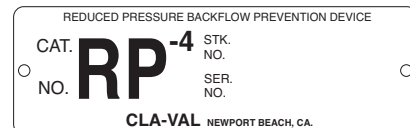

This brass plate is used on our backflow prevention assemblies. It is located on the side of the Number Two check (2" through 10"). The serial number of the assembly is also stamped on the top of the inlet flange of the Number One check.

How to Order

Because of the vast number of possible configurations and combinations available, many valves and controls are not shown in published product and price lists. For ordering information, price and availability on product that are not listed, please contact your local Cla-Val office or our factory office located at:

P. O. Box 1325
Newport Beach, California 92659-0325
(949) 722-4800
FAX (949) 548-5441



When Ordering, Please Specify

- | | | | | |
|---------------------------|--------------------------------------|------------------------|----------------------------|----------------------|
| 1. Model Number | 3. Adjustment range (as application) | 4. Valve Size | 6. Body and Trim Materials | 7. Optional Features |
| 2. Globe or Angle Pattern | | 5. Threaded or Flanged | | 8. Pressure Class |

Unless Otherwise Specified

- Globe or angle pattern are the same price
- Ductile iron body and bronze trim are standard
- X46 Flow Clean Strainer or X43 "Y" Strainer are included
- CK2 Isolation Valves are included in price on 4" and larger valve sizes (6" and larger on 600 Series)

Limited Warranty

Automatic valves and controls as manufactured by Cla-Val are warranted for three years from date of shipment against manufacturing defects in material and workmanship that develop in the service for which they are designed, provided the products are installed and used in accordance with all applicable instructions and limitations issued by Cla-Val. Electronic components manufactured by Cla-Val are warranted for one year from the date of shipment.

We will repair or replace defective material, free of charge, that is returned to our factory, transportation charges prepaid, if upon inspection, the material is found to have been defective at time of

original shipment. This warranty is expressly conditioned on the purchaser's providing written notification to Cla-Val immediate upon discovery of the defect.

Components used by Cla-Val but manufactured by others, are warranted only to the extent of that manufacturer's guarantee.

This warranty shall not apply if the product has been altered or repaired by others, Cla-Val shall make no allowance or credit for such repairs or alterations unless authorized in writing by Cla-Val.

Disclaimer of Warranties and Limitations of Liability

The foregoing warranty is exclusive and in lieu of all other warranties and representations, whether expressed, implied, oral or written, including but not limited to any implied warranties or merchantability or fitness for a particular purpose. All such other warranties and representations are hereby canceled.

Cla-Val shall not be liable for any incidental or consequential loss, damage or expense arising directly or indirectly from the use of the

product. Cla-Val shall not be liable for any damages or charges for labor or expense in making repairs or adjustments to the product. Cla-Val shall not be liable for any damages or charges sustained in the adaptation or use of its engineering data and services. No representative of Cla-Val may change any of the foregoing or assume any additional liability or responsibility in connection with the product. The liability of Cla-Val is limited to material replacements F.O.B. Newport Beach, California.

Terms of Sale

ACCEPTANCE OF ORDERS

All orders are subject to acceptance by our main office at Newport Beach, California.

CREDIT TERMS

Credit terms are net thirty (30) days from date of invoice.

PURCHASE ORDER FORMS

Orders submitted on customer's own purchase order forms will be accepted only with the express understanding that no statements, clauses, or conditions contained in said order form will be binding on the Seller if they in any way modify the Seller's own terms and conditions of sales.

PRODUCT CHANGES

The right is reserved to make changes in pattern, design or materials when deemed necessary, without prior notice.

PRICES

All prices are F.O.B. Newport Beach, California unless expressly stated otherwise on our acknowledgment of the order. Prices are subject to change without notice. The prices at which any order is accepted are subject to adjustment to the Seller's price in effect at the time of shipment. Prices do not include sales, excise, municipal, state or any other Government taxes. Minimum order charge \$100.00.

RESPONSIBILITY

We will not be responsible for delays resulting from strikes, accidents, negligence of carriers, or other causes beyond our control. Also, we will not be liable for any unauthorized product alterations or charges accruing there from.

RISK

All goods are shipped at the risk of the purchaser after they have been delivered by us to the carrier. Claims for error, shortages, etc., must be made upon receipt of goods.

EXPORT SHIPMENTS

Export shipments are subject to an additional charge for export packing.

RETURNED GOODS

1. Customers must obtain written approval from Cla-Val prior to returning any material.
2. Cla-Val reserves the right to refuse the return of any products.
3. Products more than six (6) months old cannot be returned for credit.
4. Specially produced, non-standard models cannot be returned for credit.
5. Rubber goods such as diaphragms, discs, o-rings, etc., cannot be returned for credit, unless as part of an unopened vacuum sealed repair kit which is less than six months old.
6. Goods authorized for return are subject to a 35% (\$100 minimum) restocking charge and a service charge for inspection, reconditioning, replacement of rubber parts, retesting, repainting and repackaging as required.
7. Authorized returned goods must be packaged and shipped prepaid to Cla-Val, 1701 Placentia Avenue, Costa Mesa, California 92627.





Model Repair Kits

Model 100-01 Hytrol Main Valve

BUNA-N MATERIAL				
	RUBBER KIT STOCK #	REPAIR KIT STOCK #	REBUILD ASSEMBLY STOCK #	STUD & NUT KIT STOCK #
3/8"	9169801K		21176614B	21176633J
1/2"	9169802H	21176602F	21176615A	21176634H
3/4"	9169802H	21176602F	21176615A	21176634H
1" Non-Guided	9169803F	21176601G	21176616K	21176636F
1"	9169804D	21176603E	21176617J	21176636F
1 1/4"	9169804D	21176603E	21176617J	21176636F
1 1/2"	9169804D	21176603E	21176617J	21176636F
2"	9169805A	21176608K	21176618H	21176637E
2 1/2"	9169811J	21176609J	21176619G	21176638D
3"	9169812G	21176604D	21176620D	21176639C
4"	9169813E	21176605C	21176621C	21176640K
6"	9169815K	21176606B	21176622B	21176641J
8"	9817901D	21176607A	21176623A	21176642H
10"	9817902B	21176610F	21176654C	21176643G
12"	9817903K	21176611E	21176625J	21176644F
14"	9817904H	21176612D	21176626H	21176645E
16"	9817905E	21176613C	21176627G	21176645E

Model 100-20 Hytrol Main Valve

BUNA-N MATERIAL				
	RUBBER KIT STOCK #	REPAIR KIT STOCK #	REBUILD ASSEMBLY STOCK #	STUD & NUT KIT STOCK #
3"	9169805A	21176608K	21176618H	21176637E
4"	9169812G	21176604D	21176620D	21176639C
6"	9169813E	21176605C	21176621C	21176640K
8"	9169815K	21176606B	21176622B	21176641J
10"	9817901D	21176607A	21176623A	21176642H
12"	9817902B	21176610F	21176624K	21176643G
14"	9817903K	21176611E	21176625J	21176644F
16"	9817903K	21176611E	21176625J	21176644F

Model 100-30 Hytrol Main Valve

BUNA-N MATERIAL		
	RUBBER KIT STOCK #	REBUILD ASSEMBLY STOCK #
2 1/2"	21112704H	21235401C
3"	21112702K	21235402B
4"	21112703J	21235403A
6"	27496886J	21235404K
8"	21112701A	21235405J
10"	CF	21235406H

- Rubber Kit Includes:** Diaphragm, Disc, Spacer Washers. **Model 100-30 also includes:** Stem O-Ring, Seal, Bearing O-Ring.
- Repair Kit Includes:** Diaphragm, Disc, Spacer Washers, Epoxy Coated Disc Retainer, Epoxy Coated Diaphragm Washer, Protective Washer
- Rebuild Assembly Includes:** Diaphragm, Disc, Spacer Washers, Epoxy Coated Disc Retainer, Epoxy Coated Diaphragm Washer, Protective Washer, Stainless Steel Bolts & Washers (6" & Below), Stainless Steel Studs, Nuts, & Washers (8" & Above), Stem, Stem Nut, Disc Guide, Standard Cover Spring, Cover Washer. **Model 100-30 also includes:** Upper and Lower Stem and Stem Nut, Stem O-Ring, Seal, Lower Spring, PU Bearing, Bearing O-Ring, Bearing Retainer Ring.
- Stud & Nut Kit Includes:** Stainless Steel Bolts & Washers (6" & Below), Stainless Steel Studs, Nuts, & Washers (8" & Above)



Repair Kits for 100-02/100-21 Powertrol and 100-03/100-22 Powercheck Main Valves

For: Powertrol and Powercheck Main Valves—150 Pressure Class Only

Includes: Diaphragm, Disc (or Disc Assembly) and O-rings and full set of spare Spacer Washers.

Valve Size	Kit Stock Number		Valve Size	Kit Stock Number	
	100-02			100-02 & 100-03	100-21 & 100-22
3/8"	9169901H		2 1/2"	9169910J	N/A
1/2" & 3/4"	9169902F		3"	9169911G	9169905J
1"	9169903D		4"	9169912E	9169911G
1 1/4" & 1 1/2"	9169904B		6"	9169913C	9169912E
2"	9169905J		8"	9169950E	9169913C
			10"	9169939H	9169950E
			12"	9169937B	9169939H

Consult factory for larger sizes

Repair Kits for 100-04/100-23 Hy-Check Main Valves

For: Hy-Check Main Valves—150 Pressure Class Only

Includes: Diaphragm, Disc and O-Rings and full set of spare Spacer Washers.

Valve Size	Kit Stock Number		Valve Size	Kit Stock Number	
	100-04	100-23		100-04	100-23
4"	20210901B	N/A	12"	20210905H	20210904J
6"	20210902A	20210901B	14"	20210906G	N/A
8"	20210903K	20210902A	16"	20210907F	20210905H
10"	20210904J	20210903K	20"	N/A	20210907F
			24"	N/A	20210907F

Consult factory for larger sizes

Repair Kits for Pilot Control Valves (In Standard Materials Only)

Includes: Diaphragm, Disc (or Disc Assembly), O-Rings, Gaskets or spare Screws as appropriate.

BUNA-N® (Standard Material)				VITON (For KB Controls)	
Pilot Control	Kit Stock Number	Pilot Control	Kit Stock Number	Pilot Control	Kit Stock Number
CDB	9170006C	CFM-7A	1263901K	CDB-KB	9170012A
CDB-30	9170023H	CFM-9	12223E	CRA-KB	N/A
CDB-31	9170024F	CRA (w/bucking spring)	9170001D	CRD-KB (w/bucking spring)	9170008J
CDB-7	9170017K	CRD (w/bucking spring)	9170002B	CRL-KB	9170013J
CDH-2	18225D	CRD (no bucking spring)	9170003K	CDHS-2BKB	9170010E
CDHS-2	44607A	CRD-18	20275401K	CDHS-2FKB	9170011C
CDHS-2B	9170004H	CRD-22	98923G	CDHS-18KB (no bucking spring)	9170009G
CDHS-2F	9170005E	CRL (55F, 55L)	9170007A	102C-KB	1726202D
CDHS-3C-A2	24657K	CRL60/55L-60	9170033G		
CDHS-8A	2666901A	CRL60/55L60 1"	9170042H		
CDHS-18	9170003K	CRL-4A	43413E		
CDS-4	9170014G	CRL-5 (55B)	65755B		
CDS-5	14200A	CRL-5A (55G)	20666E		
CDS-6	20119301A	CRL-18	20309801C		
CDS-6A	20349401C	Universal CRL	9170041K		
CDS-7	20349402B	CV	9170019F		
CDS-7DO	20349403A	X105L (O-ring)	00951E		
CFCM-M1	1222301C	102B-1	1502201F	Buna-N®	
CFM-2	12223E	102C-2	1726201F	CRD Disc Ret. (Solid)	C5256H
CFM-7	1263901K	102C-3	1726201F	CRD Disc Ret. (Spring)	C5255K

Repair Assemblies (In Standard Materials Only)

Control	Description	Stock Number
CF1-C1	Pilot Assembly Only	89541H
CF1-CI	Complete Float Control less Ball and Rod	89016A
CFC2-C1	Disc, Distributor and Seals	2674701E
CSM 11-A2-2	Mechanical Parts Assembly	97544B
CSM 11-A2-2	Pilot Assembly Only	18053K
33A 1"	Complete Internal Assembly and Seal	2036030B
33A 2"	Complete Internal Assembly and Seal	2040830J

When ordering, please give complete nameplate data of the valve and/or control being repaired. MINIMUM ORDER CHARGE APPLIES