

---

# CLA-VAL

**AUTOMATIC CONTROL VALVES**

**139-10/639-10**

Place this manual with personnel responsible  
for maintenance of this valve

---



## *Installation*



## *Operation*

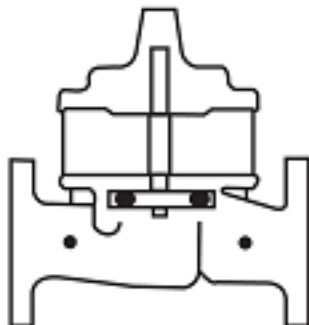

## *Maintenance*



CLA-VAL • 1701 Placentia Avenue • Costa Mesa, CA 92627 • (949) 722-4800 • info@cla-val.com  
CLA-VAL CANADA LTD. • 4687 Christie Drive • Beamsville, Ontario, LOR 1B4 Canada • (905) 563-4963

[www.cla-val.com](http://www.cla-val.com) • [info@cla-val.com](mailto:info@cla-val.com)



## Recommended Inspections

Cla-Val recommends that an inspection be performed on our products annually. The inspection should include both a visual and functional test of the main valve/component and the pilot system. The inspection ensures that no damage or premature wear occurred due to velocity, pressure, or foreign matter within the fluid that may have exceeded the valve's design. Please consult the maintenance manual for specific information on the model. Manuals are available for download at [Cla-Val.com](http://Cla-Val.com), as well as contact information for a company representative.

Accurate record-keeping is a best practice for any preventative maintenance program, and Cla-Val strongly recommends this action through an asset management program. Cla-Val provides a free asset management tool, Link2Valves [Link2Valves - Cla-Val \(cla-val.com\)](http://Link2Valves - Cla-Val (cla-val.com)), to assist in preventative maintenance record-keeping and scheduling.



# Model 100-01 HYTROL VALVE

## DESCRIPTION

The Cla-Val Model 100-01 Hytrol Valve is a main valve for Cla-Val Automatic Control Valves. It is a hydraulically operated, diaphragm-actuated, globe or angle pattern valve. This valve consists of three major components; body, diaphragm assembly, and cover. The diaphragm assembly is the only moving part. The diaphragm assembly uses a diaphragm of nylon fabric bonded with synthetic rubber. A synthetic rubber disc, contained on three and one half sides by a disc retainer and disc guide, forms a seal with the valve seat when pressure is applied above the diaphragm. The diaphragm assembly forms a sealed chamber in the upper portion of the valve, separating operating pressure from line pressure.

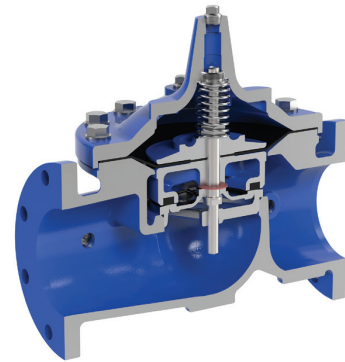

## Installation

1. Before valve is installed, pipe lines should be flushed of all chips, scale and foreign matter.
2. It is recommended that either gate or block valves be installed on both ends of the Model 100-01 Hytrol Valve to facilitate isolating the valve for preventive maintenance and repairs.
3. Place the valve in the line with flow through the valve in the direction indicated on the inlet nameplate. (See "Flow Direction" Section) **Note: Valve can be installed in the vertical or horizontal position.**
4. Allow sufficient room around valve to make adjustments and for disassembly.
5. Cla-Val Model 100-01 Hytrol Valves operate with maximum efficiency when mounted in horizontal piping with the cover UP, however, other positions are acceptable. Due to size and weight of the cover and internal components of 8 inch and larger valves, installation with the cover UP is advisable. This makes internal parts readily accessible for periodic inspection.

6. Caution must be taken in the installation of this valve to insure that galvanic and/or electrolytic action does not take place. The proper use of dielectric fittings and gaskets are required in all systems using dissimilar metals.
7. If a pilot control system is installed on the Model 100-01 Hytrol Valve, use care to prevent damage. If it is necessary to remove fittings or components, be sure they are kept clean and replaced exactly as they were.
8. After the valve is installed and the system is first pressurized, vent air from the cover chamber and pilot system tubing by loosening fittings at all high points.

## Principles of Operation

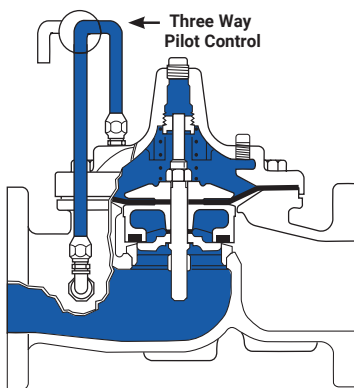

### Tight Closing Operation

When pressure from the valve inlet (or an equivalent independent operating pressure) is applied to the diaphragm chamber the valve closes drip-tight.

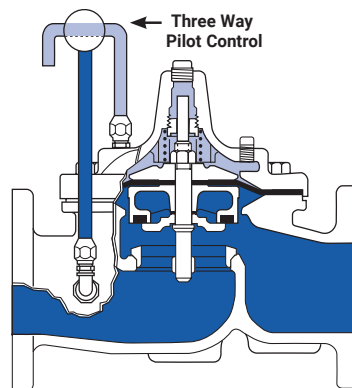

### Full Open Operation

When pressure in diaphragm chamber is relieved to a zone of lower pressure (usually atmosphere) the line pressure (5 psi Min.) at the valve inlet opens the valve.

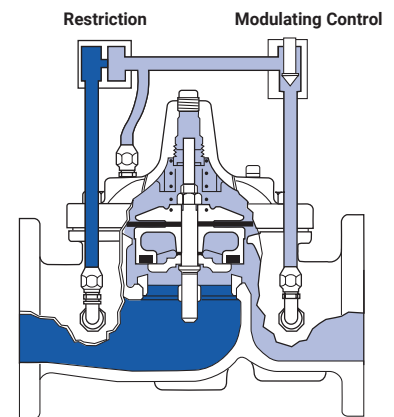

### Modulating Action

Valve modulates when diaphragm pressure is held at an intermediate point between inlet and discharge pressure. With the use of a Cla-Val. "Modulating control," which reacts to line pressure changes, the pressure above the diaphragm is varied, allowing the valve to throttle and compensate for the change.

## Flow Direction

The flow through the Model 100-01 Hytrol Valve can be in one of two directions. When flow is “up-and-over the seat,” it is in “normal” flow and the valve will fail in the open position. When flow is “over-the seat-and down,” it is in “reverse” flow and the valve will fail in the closed position. There are no permanent flow arrow markings. **The valve must be installed according to nameplate data.**

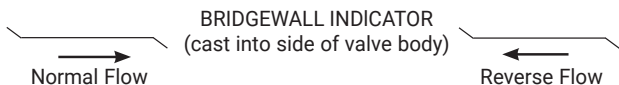

## Recommended Tools

1. Three pressure gauges with ranges suitable to the installation to be put at Hytrol inlet, outlet and cover connections.
2. Cla-Val Model X101D Valve Position Indicator. This provides visual indication of valve position without disassembly of valve.
3. Other items are: suitable hand tools such as screwdrivers, wrenches, etc., soft jawed (brass or aluminum) vise, 400 grit wet or dry sandpaper and water for cleaning.

## Troubleshooting

The following troubleshooting information deals strictly with the Model 100-01 Hytrol Valve. This assumes that all other components of the pilot control system have been checked out and are in proper working condition. (See appropriate sections in Technical Manual for complete valve).

All trouble shooting is possible without removing the valve from the line or removing the cover. It is highly recommended to permanently install a Model X101D Valve Position Indicator and three gauges in unused Hytrol inlet, outlet and cover connections.

**After checking out probable causes and remedies, the following three checks can be used to diagnose the nature of the problem before maintenance is started. They must be done in the order shown.**

Service Suggestions		
Symptom	Possible Cause	Solutions
Fails to Close	Closed isolation valves in control system, or in main line.	Open Isolation valves.
	Lack of cover chamber pressure	Check upstream pressure, pilot system, strainer, tubing, valves, or needle valves for obstruction.
	Diaphragm damaged. (See Diaphragm Check.)	Replace diaphragm.
	Diaphragm assembly inoperative. Corrosion or excessive scale build up on valve stem. (See Freedom of Movement Check)	Clean and polish stem. Inspect and replace any damaged or badly eroded part.
	Mechanical obstruction. Object lodged in valve. (See Freedom of Movement Check)	Remove obstruction.
	Worn disc. (See Tight Sealing Check)	Replace disc.
	Badly scored seat (See Tight Sealing Check)	Replace seat.
Fails to Open	Closed upstream and/or downstream isolation valves in main line.	Open isolation valves.
	Insufficient line pressure.	Check upstream pressure. (Minimum 5 psi flowing line pressure differential.)
	Diaphragm assembly inoperative. Corrosion or excessive buildup on valve stem. (See Freedom of Movement Check)	Clean and polish stem. Inspect and replace any damaged or badly eroded part.
	Diaphragm damaged. (For valves in “reverse flow” only)	Replace diaphragm.

## Three Checks

The Model 100-01 Hytrol Valve has only one moving part (the diaphragm and disc assembly). So, there are only three major types of problems to be considered.

**First:** Valve is stuck - that is, the diaphragm assembly is not free to move through a full stroke either from open to close or vice versa.

**Second:** Valve is free to move and can't close because of a worn out diaphragm.

**Third:** Valve leaks even though it is free to move and the diaphragm isn't leaking.

**CAUTION:** Care should be taken when doing the troubleshooting checks on the Model 100-01 Hytrol Valve. These checks do require the valve to open fully. This will either allow a high flow rate through the valve, or the downstream pressure will quickly increase to the inlet pressure. In some cases, this can be very harmful. Where this is the case, and there are no block valves in the system to protect the downstream piping, it should be realized that **the valve cannot be serviced under pressure.** Steps should be taken to remedy this situation before proceeding any further.



**Three Checks (cont.)**

**DIAPHRAGM CHECK (#1)**

1. Shut off pressure to the Hytrol Valve by slowly closing upstream and downstream isolation valves. **SEE CAUTION.**
2. Disconnect or close all pilot control lines to the valve cover and leave only one fitting in highest point of cover open to atmosphere.
3. With the cover vented to atmosphere, slowly open upstream isolation valve to allow some pressure into the Hytrol Valve body. Observe the open cover tapping for signs of continuous flow. It is not necessary to fully open isolating valve. Volume in cover chamber capacity chart will be displaced as valve moves to open position. Allow sufficient time for diaphragm assembly to shift positions. If there is no continuous flow, you can be quite certain the diaphragm is sound and the diaphragm assembly is tight. If the fluid appears to flow continuously this is a good reason to believe the diaphragm is either damaged or it is loose on the stem. In either case, this is sufficient cause to remove the valve cover and investigate the leakage. (See "Maintenance" section for procedure.)

Cover Chamber Capacity (Liquid Volume displaced when valve opens)		
Valve Size (Inches)	Displacement	
	Gallons	Liters
1-1/4"	0.020	0.07
1-1/2"	0.020	0.07
2"	0.032	0.12
2-1/2"	0.043	0.16
3"	0.080	0.30
4"	0.169	0.64
6"	0.531	2.0
8"	1.26	4.8
10"	2.51	9.5
12"	4.00	15.1
14"	6.50	24.6
16"	9.57	36.0
18"	11.00	41.6
20"	12.00	45.4
24"	29.00	109.8
30"	42.00	197.0
36"	90.00	340.0

**FREEDOM OF MOVEMENT CHECK (#2)**

4. Determining the Hytrol Valve's freedom of movement can be done by one of two methods.
5. For most valves it can be done after completing Diaphragm Check (Steps 1, 2, and 3). **SEE CAUTION.** At the end of step 3 the valve should be fully open.
6. If the valve has a Cla-Val X101D Position Indicator, observe the indicator to see that the valve opens wide. Mark the point of maximum opening.
7. Re-connect enough of the control system to permit the application of inlet pressure to the cover. Open pilot system cock so pressure flows from the inlet into the cover.
8. While pressure is building up in the cover, the valve should close smoothly. There is a hesitation in every Hytrol Valve closure, which can be mistaken for a mechanical bind. The stem will appear to stop moving very briefly before going to the closed position. This slight pause is caused by the diaphragm flexing at a particular point in the valve's travel and is not caused by a mechanical bind.
9. When closed, a mark should be made on the X101D Valve position indicator corresponding to the "closed" position. The distance between the two marks should be approximately the stem travel shown in chart.
10. If the stroke is different than that shown in stem travel chart this is a good reason to believe something is mechanically restricting the stroke of the valve at one end of its travel. If the flow does not

stop through the valve when in the indicated "closed" position, the obstruction probably is between the disc and the seat. If the flow does stop, then the obstruction is more likely in the cover. In either case, the cover must be removed, and the obstruction located and removed. The stem should also be checked for scale build-up. (See "Maintenance" section for procedure.)

Stem Travel (Fully open to fully closed)			
Valve Size (Inches)		Travel (Inches)	
Inches	MM	Inches	MM
1-1/4"	32	0.04"	10
1-1/2"	40	0.04"	10
2"	50	0.06"	15
2-1/2"	65	0.07"	18
3"	80	0.08"	20
4"	100	1.1"	28
6"	150	1.7"	43
8"	200	2.3"	58
10"	250	2.8"	71
12"	300	3.4"	86
14"	350	4.0"	100
16"	400	4.5"	114
18"	450	5.1"	130
20"	500	5.6"	143
24"	600	6.7"	165
30"	800	7.5"	190
36"	900	8.5"	216

11. For valves 6" and smaller, the Hytrol Valve's freedom of movement check can also be done after all pressure is removed from the valve. **SEE CAUTION.** After closing inlet and outlet isolation valves and bleeding pressure from the valve, check that the cover chamber and the body are temporarily vented to atmosphere. Insert fabricated tool into threaded hole in top of valve stem, and lift the diaphragm assembly manually. Note any roughness. The diaphragm assembly should move smoothly throughout entire valve stroke. The tool is fabricated from rod that is threaded on one end to fit valve stem and has a "T" bar handle of some kind on the other end for easy gripping. (See chart in Step 4 of "Disassembly" Section.)

12. Place marks on this diaphragm assembly lifting tool when the valve is closed and when manually positioned open. The distance between the two marks should be approximately the stem travel shown in stem travel chart. If the stroke is different than that shown, there is a good reason to believe something is mechanically restricting the stroke of the valve. The cover must be removed, and the obstruction located and removed. The stem should also be checked for scale build-up. (See "Maintenance" section for procedure.)

**TIGHT SEALING CHECK (#3)**

13. Test for seat leakage after completing checks #1 & #2 (Steps 1 to 12). **SEE CAUTION.** Close the isolation valve downstream of the Hytrol Valve. Apply inlet pressure to the cover of the valve, wait until it closes. Install a pressure gauge between the two closed valves using one of the two ports in the outlet side of the Hytrol. Watch the pressure gauge. If the pressure begins to climb, then either the downstream isolation valve is permitting pressure to creep back, or the Hytrol is allowing pressure to go through it. Usually the pressure at the Hytrol inlet will be higher than on the isolation valve discharge, so if the pressure goes up to the inlet pressure, you can be sure the Hytrol is leaking. Install another gauge downstream of isolating valve. If the pressure between the valves only goes up to the pressure on the isolation valve discharge, the Hytrol Valve is holding tight, and it was just the isolation valve leaking.



## Maintenance

### PREVENTATIVE MAINTENANCE

The Cla-Val Model 100-01 Hytrol Valve requires no lubrication or packing and a minimum of maintenance. However, a periodic inspection schedule should be established to determine how the operating conditions of the system are affecting the valve. The effect of these actions must be determined by inspection.

### DISASSEMBLY

Inspection or maintenance can be accomplished without removing the valve from the line. Repair kits with new diaphragm and disc are recommended to be on hand before work begins.

**WARNING:** Maintenance personnel can be injured and equipment damaged if disassembly is attempted with pressure in the valve. **SEE CAUTION.**

1. Close upstream and downstream isolation valves and **independent operating pressure when used** to shut off all pressure to the valve.
2. Loosen tube fittings in the pilot system to remove pressure from valve body and cover chamber. After pressure has been released from the valve, use care to remove the controls and tubing. Note and sketch position of tubing and controls for re-assembly. The schematic in front of the Technical Manual can be used as a guide when reassembling pilot system.
3. Remove cover nuts and remove cover. If the valve has been in service for any length of time, chances are the cover will have to be loosened by driving upward along the edge of the cover with a **dull cold chisel**.

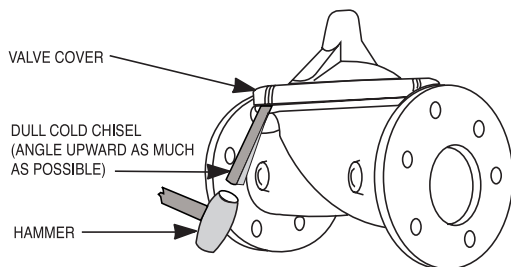

On 6" and smaller valves block and tackle or a power hoist can be used to lift valve cover by inserting proper size eye bolt in place of the center cover plug. on 8" and larger valves there are 4 holes (5/8" – 11 size) where jacking screws and/or eye bolts may be inserted for lifting purposes. **Pull cover straight up** to keep from damaging the integral seat bearing and stem.

Cover Center Plug Size	
Valve Size (Inches)	Thread Size (NPT)
1-1/4" - 1-1/2"	1/4"
2" - 3"	1/2"
4" - 6"	3/4"
8" - 10"	1"
12"	1-1/4"
14"	1-1/2"
16"	2"
18" - 24"	1"
30" & 36"	2"

4. Remove the diaphragm and disc assembly from the valve body. With smaller valves this can be accomplished by hand by **pulling straight up on the stem so as not to damage the seat bearing**. On large valves, an eye bolt of proper size can be installed in the stem and the diaphragm assembly can be then lifted with a block and tackle or power hoist. Take care not to damage the stem or bearings. The valve won't work if these are damaged.

Valve Stem Thread Size	
Valve Size (Inches)	Thread Size (UNF Internal)
1-1/4" - 2-1/2"	10 - 32
3" - 4"	1/4 - 28
6" - 14"	3/8 - 24
16"	1/2 - 20
18"	3/4 - 16
20"	3/4 - 16
24"	3/4 - 16
30"	3/4 - 16
36"	3/4 - 16

5. The next item to remove is the stem nut. Examine the stem threads above the nut for signs of mineral deposits or corrosion. If the threads are not clean, use a wire brush to remove as much of the residue as possible. Attach a good fitting wrench to the nut and give it a sharp "rap" rather than a steady pull. Usually several blows are sufficient to loosen the nut for further removal. On the smaller valves, the entire diaphragm assembly can be held by the stem in a vise **equipped with soft brass jaws** before removing the stem nut.

The use of a pipe wrench or a vise without soft brass jaws scars the fine finish on the stem. No amount of careful dressing can restore the stem to its original condition. Damage to the finish of the stem can cause the stem to bind in the bearings and the valve will not open or close.

6. After the stem nut has been removed, the diaphragm assembly breaks down into its component parts. Removal of the disc from the disc retainer can be a problem if the valve has been in service for a long time. Using two screwdrivers inserted along the outside edge of the disc usually will accomplish its removal. Care should be taken to preserve the spacer washers in water, particularly if no new ones are available for re-assembly.

7. The only part left in the valve body is the seat which ordinarily does not require removal. Careful cleaning and polishing of inside and outside surfaces with 400 wet/dry sandpaper will usually restore the seat's sharp edge. If, however, it is badly worn and replacement is necessary, it can be easily removed.

Seats in valve sizes 1 1/4" through 6" are threaded into the valve body. They can be removed with accessory X109 Seat Removing Tool available from the factory. On 8" and larger valves, the seat is held in place by flat head machine screws. Use a tight-fitting, long shank screwdriver to prevent damage to seat screws. If upon removal of the screws the seat cannot be lifted out, it will be necessary to use a piece of angle or channel iron with a hole drilled in the center. Place it across the body so a long stud can be inserted through the center hole in the seat and the hole in the angle iron. By tightening the nut a uniform upward force is exerted on the seat for removal.

**NOTE:** Do not lift up on the end of the angle iron as this may force the integral bearing out of alignment, causing the stem to bind.

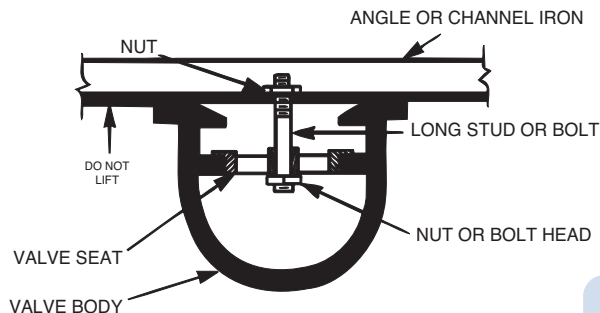

## Lime Deposits

One of the easiest ways to remove lime deposits from the valve stem or other metal parts is to dip them in a 5-percent muriatic acid solution just long enough for the deposit to dissolve. This will remove most of the common types of deposits. **CAUTION: USE EXTREME CARE WHEN HANDLING ACID.** Rinse parts in water before handling. If the deposit is not removed by acid, then a fine grit (400) wet or dry sandpaper can be used with water.

## Inspection of Parts

After the valve has been disassembled, each part should be examined carefully for signs of wear, corrosion, or any other abnormal condition. Usually, it is a good idea to replace the rubber parts (diaphragm and disc) unless they are free of signs of wear. These are available in a repair kit. Any other parts which appear doubtful should be replaced. **WHEN ORDERING PARTS, BE SURE TO GIVE COMPLETE NAMEPLATE DATA, ITEM NUMBER AND DESCRIPTION.**

**NOTE:** If a new disc isn't available, the existing disc can be turned over, exposing the unused surface for contact with the seat. The disc should be replaced as soon as practical.

## Reassembly

1. Reassembly is the reverse of the disassembly procedure. If a new disc has been installed, it may require a different number of spacer washers to obtain the right amount of "grip" on the disc. When the diaphragm assembly has been tightened to a point where the diaphragm cannot be twisted, the disc should be compressed very slightly by the disc guide. Excessive compression should be avoided. Use just enough spacer washers to hold the disc firmly without noticeable compression.

2. **MAKE SURE THE STEM NUT IS VERY TIGHT.** Attach a good fitting wrench to the nut and give it a sharp "rap" rather than a steady pull. Usually several blows are sufficient to tighten the stem nut for final tightening. Failure to do so could allow the diaphragm to pull loose and tear when subjected to pressure.

3. Carefully install the diaphragm assembly by lowering the stem through the seat bearing. Take care not to damage the stem or bearing. Line up the diaphragm holes with the stud or bolt holes on the body. On larger valves with studs, it may be necessary to hold the diaphragm assembly up part way while putting the diaphragm over the studs.

4. Put spring in place and replace cover. Make sure diaphragm is lying smooth under the cover.

5. Tighten cover nuts firmly using a cross-over pattern until all nuts are tight.

6. Test Hytrol Valve before re-installing pilot valve system.

## Test Procedure After Valve Assembly

There are a few simple tests which can be made in the field to make sure the Hytrol Valve has been assembled properly. Do these before installing pilot system and returning valve to service. These are similar to the three troubleshooting tests.

1. Check the diaphragm assembly for freedom of movement after all pressure is removed from the valve. **SEE CAUTION.** Insert fabricated tool into threaded hole in top of valve stem, and lift the diaphragm assembly manually. Note any roughness, sticking or grabbing. The diaphragm assembly should move smoothly throughout entire valve stroke. The tool is fabricated from rod that is threaded on one end to fit valve stem (See chart in Step 4 of "Disassembly" section.) and has a "T" Bar handle of some kind on the other end for easy gripping.

Place marks on this diaphragm assembly lifting tool when the valve is closed and when manually positioned open. The distance between the two marks should be approximately the stem travel shown in stem travel chart. (See "Freedom of Movement Check" section.) If the stroke is different than that shown, there is a good reason to believe something is mechanically restricting the stroke of the valve. The cover must be removed, the obstruction located and removed. (See "Maintenance" section for procedure.)

Due to the weight of the diaphragm assembly this procedure is not possible on valves 8" and larger. on these valves, the same determination can be made by carefully introducing a low pressure-less than five psi) into the valve body with the cover vented. **SEE CAUTION.** Looking in cover center hole see the diaphragm assembly lift easily without hesitation, and then settle back easily when the pressure is removed.

2. To check the valve for drip-tight closure, a line should be connected from the inlet to the cover, and pressure applied at the inlet of the valve. If properly assembled, the valve should hold tight with as low as ten PSI at the inlet. (See "Tight Sealing Check" section.)

3. With the line connected from the inlet to the cover, apply full working pressure to the inlet. Check all around the cover for any leaks. Re-tighten cover nuts if necessary to stop leaks past the diaphragm.

4. Remove pressure, then re-install the pilot system and tubing exactly as it was prior to removal. **Bleed air from all high points.**

5. Follow steps under "Start-Up and Adjustment" Section in Technical Manual for returning complete valve back to service.



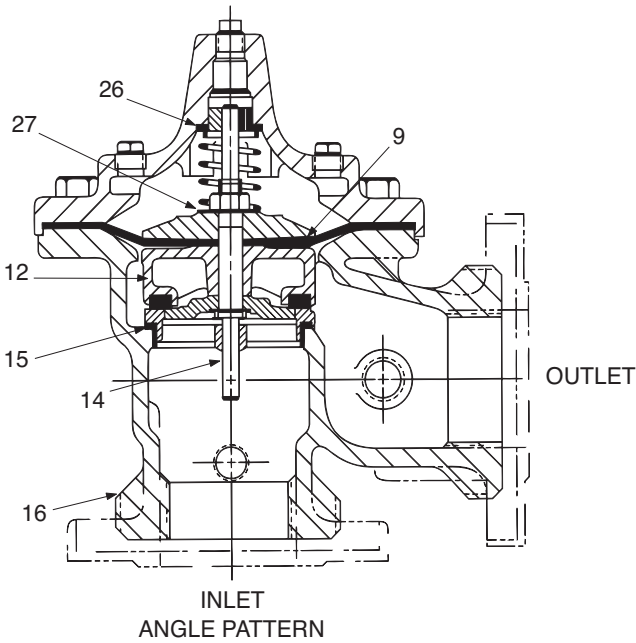
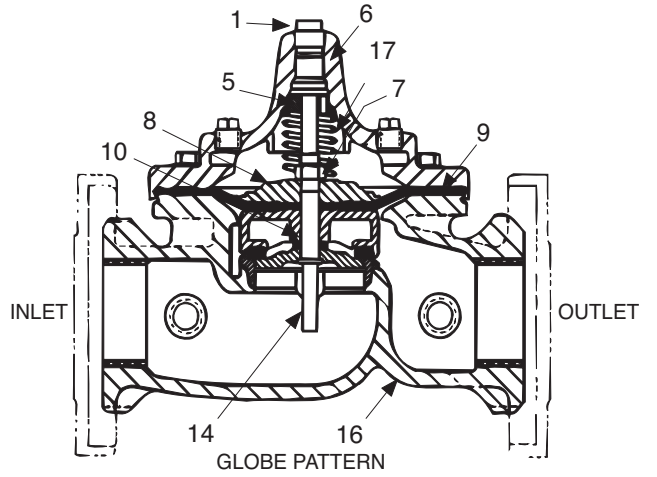
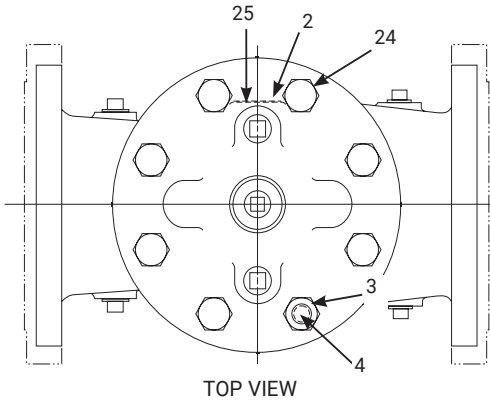

Item No.	Description
1	Pipe Plug
2	Drive Screws (for nameplate)
3	Hex Nut (8" and larger)
4	Stud (8" and larger)
5	Cover Bearing
6	Cover
7	Stem Nut
8	Diaphragm Washer
9	Diaphragm
10	Spacer Washers
11	Disc Guide
12	Disc Retainer
13	Disc
14	Stem
15	Seat
16	Body
17	Spring
22	Flat Head Screws (8" and larger)
23	Seat O-Ring
24	Hex Head Bolt (1-1/4" thru 4")
25	Nameplate
26	Upper Spring Washer (Epoxy coated valves only)
27	Lower Spring Washer (Epoxy coated valves only)
28	Cover Bearing Housing (16" only)
29	Cover O-Ring (16" only)
30	Hex Bolt (16" only)
31	Pipe Cap (16" only)

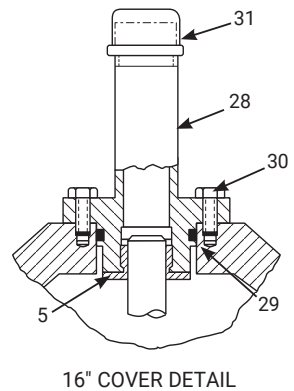
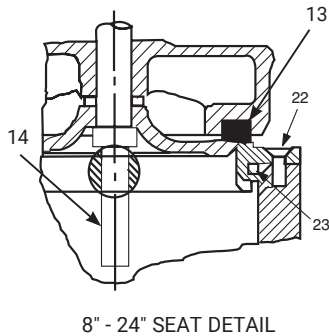
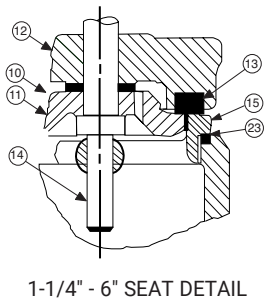



# Model 100-01 HYTROL VALVE SERVICE DATA

### DESCRIPTION 100-01 HYTROL VALVE

The Cla-Val Model 100-01 Hytrol Valve is a main valve for Cla-Val Automatic Control Valves. It is a hydraulically operated, diaphragm-actuated, globe or angle pattern valve. This valve consists of three major components; body, diaphragm assembly, and cover. The diaphragm assembly is the only moving part. The diaphragm assembly uses a diaphragm of nylon fabric bonded with synthetic rubber. A synthetic rubber disc, contained on three and one half sides by a disc retainer and disc guide, forms a seal with the valve seat when pressure is applied above the diaphragm. The diaphragm assembly forms a sealed chamber in the upper portion of the valve, separating operating pressure from line pressure.



### DESCRIPTION 100-20 600 SERIES HYTROL VALVE

The Cla-Val Model 100-20 Hytrol Valve (600 Series main valve) have only one part -the body- that is different from standard 100 Series Cla-Val main valve parts. The remaining parts of the 600 series main valve are standard Cla-Val main valve parts. All service and maintenance information for the standard 100 Series main valves also apply to the 600 series main valves. The most important thing to remember when ordering main valve repair kits and replacement parts, except for the body, all other parts are going to be for a smaller size main valve. Cla-Val identifies main valve parts with the flange size of the standard 100 Series main valve. Refer to the "Main Valve Sizes" chart below.

## Hytrol Service Data

Hytrol Service Data																			
Hytrol Size				Stem Travel		Cover Capacity Displacement		Cover Center NPT	Cover Nut or Bolt <sup>(1)</sup>					Cover Lifting Holes	Valve Stem Internal Thread	Stem Nut <sup>(3)</sup>			
100-01		100-20							Thread	Socket	Qty	Torque, Lubricated <sup>(2)</sup>				Thread	Socket (Long)	Torque, Lubricated <sup>(2)</sup>	
IN	MM	IN	MM	IN	MM	Gallons	Liters					FT. LBS	IN. LBS			FT. LBS	IN. LBS		
1	25	—	—	0.24	6	0.02	—	1/4	1/4 - 20	7/16	8	—	80	—	—	3/8 - 24	9/16	—	80
1 1/4	32	—	—	0.49	12	0.02	0.08	1/4	5/16 - 18	1/2	8	12	—	—	#10 - 32	7/16 - 20	11/16	12	—
1 1/2	40	—	—	0.49	12	0.02	0.08	1/4	5/16 - 18	1/2	8	12	—	—	#10 - 32	7/16 - 20	11/16	12	—
2	50	3	80	0.59	15	0.03	0.12	1/2	3/8 - 16	9/16	8	20	—	—	#10 - 32	1/2 - 20	3/4	16	—
2 1/2	65	—	—	0.71	18	0.04	0.16	1/2	7/16 - 14	5/8	8	36	—	—	#10 - 32	5/8 - 18	15/16	32	—
3	80	4	—	0.84	21	0.08	0.3	1/2	1/2 - 13	3/4	8	50	—	—	1/4 - 28	5/8 - 18	15/16	32	—
4	100	6	—	1.09	28	0.17	0.64	3/4	3/4 - 10	1 1/8	8	125	—	—	1/4 - 28	3/4 - 16	1 1/8	55	—
6	150	8	—	1.58	40	0.53	2.01	3/4	3/4 - 10	1 1/8	12	125	—	—	3/8 - 24	7/8 - 14	1 5/16	100	—
8	200	10	—	2.24	57	1.26	4.77	1	3/4 - 10	1 1/4	16	125	—	5/8 - 11	3/8 - 24	1 1/8 - 12	1 3/4	180	—
10	250	12	—	2.71	69	2.51	9.5	1	7/8 - 9	1 7/16	20	160	—	3/4 - 10	3/8 - 24	1 1/4 - 12	1 7/8	300	—
12	300	14, 16	350, 400	3.34	85	4.00	15.14	1 1/4	1 1/8 - 7	1 13/16	20	320	—	3/4 - 10	3/8 - 24	1 1/2 - 12	2 1/4	500	—
14	350	—	—	4.08	104	6.50	24.61	1 1/2	1 1/4 - 7	2	20	450	—	1 - 8	3/8 - 24	1 1/2 - 12	2 1/4	500	—
16	400	18, 20, 24	450, 500, 600	4.58	116	9.60	36.34	2	1 1/4 - 7	2	20	450	—	1 - 8	1/2 - 20	2 - 16	3	600	—
18	500	—	—	5.13	130	11.00	42	1	1 1/4 - 7	2	24	450	—	1 - 8	3/4 - 16	2 1/4 - 16	3 7/16	1000	—
20	500	—	—	5.63	143	12.00	45.42	1	1 3/8 - 6	2 3/16	24	600	—	1 - 8	3/4 - 16	2 1/4 - 16	3 7/16	1000	—
24	600	30	—	6.50	165	29.00	109.78	1	1 1/2 - 12	2 3/8	24	850	—	1 1/8 - 7	3/4 - 16	3 - 12	4 5/8	1600	—
30	750	36	900	8.00	203	42.00	158.99	2	1 1/2 - 12	2 3/8	32	850	—	1 1/8 - 7	3/4 - 16	3 - 12	4 5/8	3000	—
36	900	42, 48, 56	1050, 1200, 1400	8.71	221	90.00	340.69	2	1 3/4 - 10	2 3/4	36	1250	—	1 1/4 - 12	3/4 - 16	3 1/2 - 8	6	3000	—

(1) Valve sizes 6" and smaller use hex bolts for cover fasteners. Valve sizes 8" and larger use studs with hex nuts.

(2) Clean all threads and apply anti-seize prior to reassembly of threaded fasteners. Torque values are based on standard SST material.

(3) Only stem nuts supplied by CLA-VAL shall be used.







— MODEL — **100-20**  
(Reduced Internal Port)

# 600 Series Hytrol Valve

## SERVICE AND MAINTENANCE OF 600 SERIES VALVES

The 600 series main valves have only one part -the body- that is different from standard 100 Series Cla-Val main valve parts. The remaining parts of the 600 series main valve are standard Cla-Val main valve parts. All service and maintenance information for the standard 100 Series main valves in this manual also apply to the 600 series main valves.

The most important thing to remember when ordering main valve repair kits and replacement parts, except for the body, all other parts are going to be for a smaller size main valve. Cla-Val identifies main valve parts with the flange size of the standard 100 Series main valve. Refer to the "Main Valve Sizes Comparison" chart. For example, if you are servicing a 6" 100-20 Hytrol and needed a repair kit, you would order a repair kit for a 4" 100-01 Hytrol. This kit is also suitable for a 6" 100-20 Hytrol. Complete Technical Manuals include a repair kit data sheet N-RK that shows this relationship.

When you order repair parts, it is a good idea to include valve nameplate data (size, catalog number, and part number) and description of the parts desired. Do this to be sure parts will fit the valve you are working on and not be too big for it. Pilot controls and repair kits maintenance information remain the same for 100 or 600 Series valves.

## UNDERSTANDING THE 600 SERIES VALVES

In 1987, Cla-Val introduced the Model 100-20 Hytrol as the basic main valve for the 600 Series of automatic control valves. To identify all new valves using the 100-20 Hytrol, an existing catalog number is modified. Making a 600 Series catalog number is simply done by using a "6" in front of the two digit catalog numbers or replacing the "2" with a "6" in three digit catalog numbers. Current schematics reflect both catalog numbers together separated by a slash ( i.e. - 90-01/690-01, 58-02/658-02, 210-01/610-01, etc). Since these two valves 'share' the same catalog number and schematic, they provide the same function in a system. The only difference between the two valves is the relative capacity of the two main valve series.

The 100-01 Hytrol is the basic main valve for Cla-Val automatic control valves. This valve is the current version of the Clayton Hytrol valve design originated in 1936. The 100-01 Hytrol is designed as a full flow area valve. This means that the inlet, seat and outlet openings are the same size. Thus, the pressure drop is kept to a minimum for this globe style design.

The 100-20 Hytrol valve has all of the basic features and advantages of the original 100-01 Hytrol. Only one part has been changed - the body. It is designed with different size inlet, seat and outlet openings. The 100-20 Hytrol has inlet and outlet flanges one valve size larger than the seat opening size. This results in what is sometimes called a 'reduced port' main valve. For example, a 4" 100-20 valve has a 3" seat. Note: valve size is always determined by the flange size. The following chart compares the 100-01 and the 100-20 main valves.

Basic Main Valve Size Comparison		
Globe Pattern Valves		
Flange Size (inch)	Seat Size	
	100-01 (100 Series)	100-20 (600 Series)
3	3	2
4	4	3
6	6	4
8	8	6
10	10	8
12	12	10
14	14	----
16	16	12
18	----	16
20	20	16
24	24	16
30	30	24
36	36	30
42	----	36
48	----	36
Angle Pattern Valves		
Flange Size (inch)	Seat Size	
	100-01 (100 Series)	100-20 (600 Series)
4	4	3
6	6	4
8	8	6

The 100-20 Hytrol is available only in ductile iron, 150 and 300 pressure class, and Bronze trim standard. Available extra cost main valve options include stainless steel trim, epoxy coating, Dura-Kleen stem, Delrin sleeved stem, and high temperature rubber parts. All four basic main valves have a 600 Series version available with all of the same benefits and size relationships. The following chart shows the relationship of Cla-Val main valve catalog numbers.

### Cla-Val Main Valves

Catalog Name	Catalog Number		
	Circa 1936	100-Series	600 Series
Hytrol	100 (Angle =2100)	100-01	100-20
Powertrol	100P & 100PA	100-02	100-21
Powercheck	100PC & 100PCA	100-03	100-22
Hycheck	181	100-04	100-23

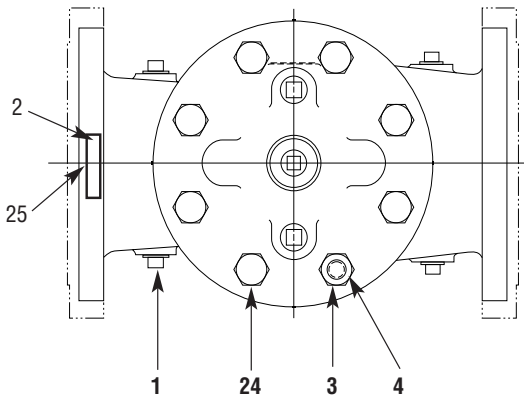

TOP VIEW

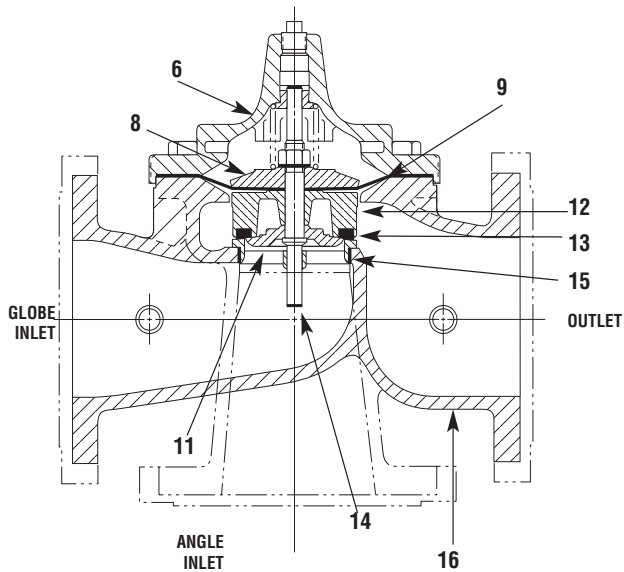

ANGLE INLET

OUTLET

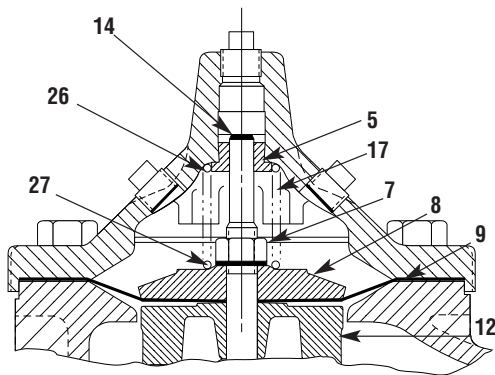

3" - 6" COVER DETAIL

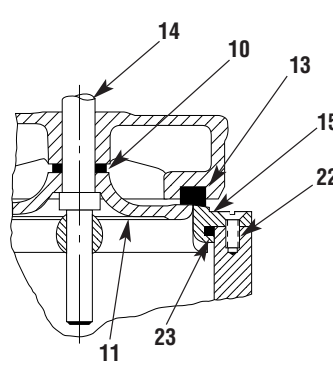

10" - 24" SEAT DETAIL

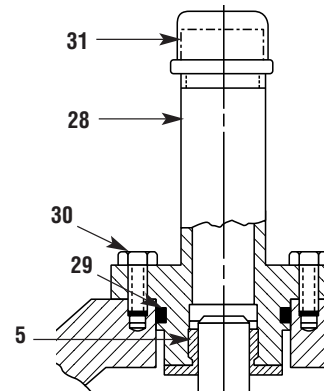

20" - 24" COVER DETAIL

PARTS LIST

NO. DESCRIPTION

- 1 Pipe Plug
- 2 Drive Screws (for nameplate)
- 3 Hex Nut (8" and larger)
- 4 Stud (8" and larger)
- 5 Cover Bearing
- 6 Cover
- 7 Stem Nut
- 8 Diaphragm Washer
- 9 Diaphragm
- 10 Spacer Washers
- 11 Disc Guide
- 12 Disc Retainer
- 13 Disc
- 14 Stem
- 15 Seat
- 16 Body
- 17 Spring
- 22 Flat Head Screws (10" and larger)
- 23 Seat O-Ring
- 24 Hex Bolt (3" Thru 6")
- 25 Nameplate (Mounted on inlet flange)
- 26 Upper Spring Washer (Epoxy coated valves only)
- 27 Lower Spring Washer (Epoxy coated valves only)
- 28 Cover Bearing Housing (20" & 24" & 30")
- 29 Cover Bearing Housing O-Ring (20" & 24" & 30")
- 30 Hex Bolt (20" & 24")
- 31 Pipe Cap (20" & 24" & 30")

WHEN ORDERING PARTS, BE SURE TO GIVE COMPLETE NAMEPLATE DATA, ITEM NUMBER AND DESCRIPTION.



— MODEL —

# CTC-33

## Electronic Timer Control



### CTC-33 Electronic Timer Control Specifications

Maximum Pressure:	232 psi (16 bar)
Temperature Range:	14° - 176°F (-10° - +80°C)
	Battery: 14° - 140°F (-10° - +60°C)
Enclosure Protection:	IP68; Validated 1 month at 0.2 bar (2m water depth)
Battery Type:	Lithium 9V/PP3 (Lifetime: ~2 years for 2 actions/day @ 20°C)
Solenoid:	3-Way Bi-Stable Orifice Size: 0.05 in (1.2mm) Voltage: 6VDC (minimum)
Rules:	Up to 6 actions (3X opening-closing per day) • Time and calendar
Fluids:	Water
Port Size:	1/8-inch FNPT Threaded

- Precise valve on-off control
- Completely self-contained
- Programmable daylight savings times
- Two Year Battery Life
- Retains stored data even after battery is depleted
- Direct control of valve opening and closing 4 times daily
- Interval Timing Capable
- IP68 submersible
- Use this valve for Pressure Management and Water Quality Control applications
- Combines with pressure, flow or level control
- Ideal for remote valve location control

The Cla-Val CTC-33 Electronic Timer Control is a battery powered, programmable on-off control used for opening and closing Cla-Val main valves according to time schedule. Up to four opening and closing times per day can be set for a weekly schedule.

The CTC-33 offers powerful valve control for remote locations and valve automation applications.

### Materials

Electronic Enclosure:	PVC
Solenoid Body:	Stainless Steel
Seals:	NBR
Programming Interface:	Compatible with Windows 8, 7 Vista and XP

### CTC-33 Electronic Timer Control Typical Applications

#### Pressure Management / Water Savings

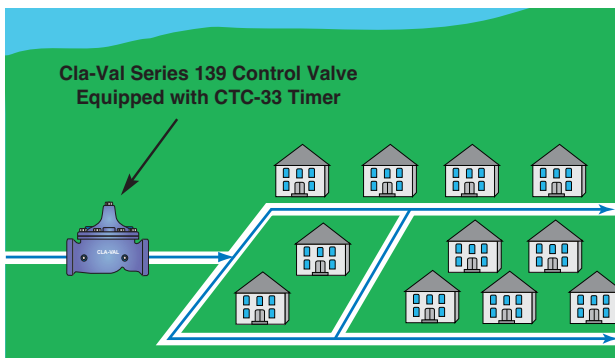

The CTC-33 Timer Control is used for pressure management applications in water distribution systems where SCADA control is not available. Use a 139 Series Cla-Val Pressure Control Valve equipped with the CTC-33 Timer to change pressure during periods of high and low demand according to pre-set schedule to reduce leaks and pipe burst frequency, while delivering adequate supply.

#### Maintaining Water Quality

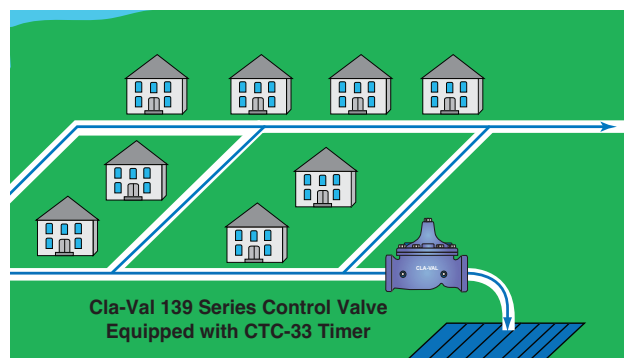

The CTC-33 Electronic Timer Control is used in 139 Series Control Valves to automate circulating water requirements in distribution system applications. Valve opening and closing time of day and duration can be set according to system requirements for convenient flushing and circulating during times of low flow to optimize water quality.

## Electronic Timer Control

Simple • Reliable • Exceptional Control

### CTC-33: A rule-based programmable timer control

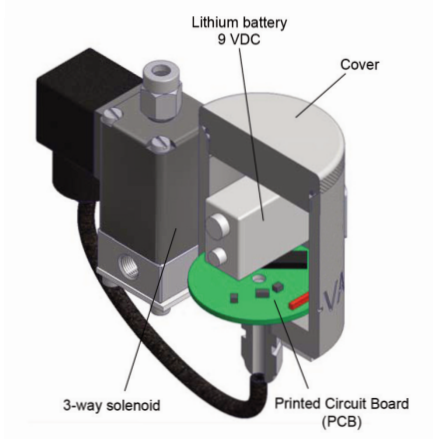

**Example of a typical assembly:**  
 Cla-Val 139 Series Control Valve  
 with the CTC-33 Electronic Timer Control

### CTC-33: Operating Mode

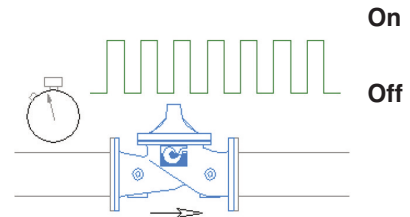

**Time Mode:** Daily On/Off cycles; programmable on a 7 day/week cycle/Interval Timing

### Custom USB Cable

- Orange USB Communications Cable is required for programming and monitoring.
- Free downloadable software at: [www.cla-val.com/software-driver-library.php](http://www.cla-val.com/software-driver-library.php)
- Stock number 20519203A



**When ordering the CTC-33, please specify:**  
 Stock number 20740103D

visit [www.cla-val.com](http://www.cla-val.com) for more information  
 Call the factory at 800.942.6326  
 Email us at [info@cla-val.com](mailto:info@cla-val.com)



## CTC-33 Timer/Controller

### Initial Mechanical Installation

RDH20150702

### CTC-33 Major Components

Battery chamber  
and communication  
port access

IP-68 rated

Programmable  
timer controller



External,  
Three-Way  
latching -type  
Solenoid

Three 1/8" NPT to  
metric thread  
adapter-connectors  
included

Use p/n 20740103D for  
complete assembly



## Exhaust Thread Adapter

Install Brass Adapter on flare exhaust port (shorter threads down)

1/8" Metric flare to  
1/8" NPTF thread

NOTE: Deeper threads  
should be up

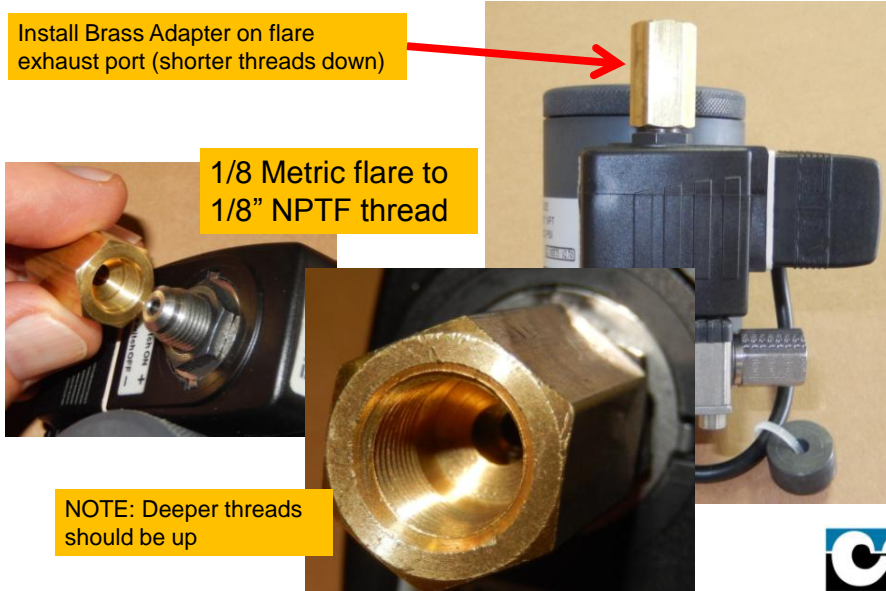

## Two Body port thread Adapters

1/8" BSPP male TO  
1/8" NPT female

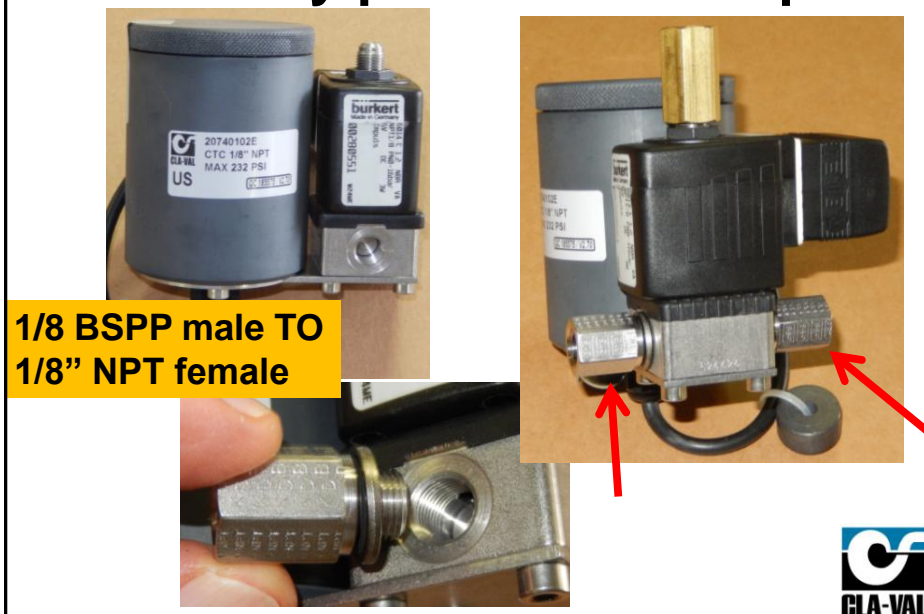



## CTC-33 Manual Operation



Use this magnet

Do not remove



Place on  
CTC-33  
housing to  
manually  
shift solenoid

CTC-33 must have fresh 9 volt battery for this to work





# Model X46

## PRESSURE REDUCING CONTROL

- Self Scrubbing Cleaning Action
- Straight Type or Angle Type

The Cla-Val Model X46 Strainer is designed to prevent passage of foreign particles larger than 0.015". It is especially effective against such contaminant as algae, mud, scale, wood pulp, moss, and root fibers. There is a model for every Cla-Val valve.

The X46 Flow Clean strainer operates on a velocity principle utilizing the circular "air foil" section to make it self cleaning. Impingement of particles is on the "leading edge" only. The low pressure area on the downstream side of the screen prevents foreign particles from clogging the screen. There is also a scouring action, due to eddy currents, which keeps most of the screen area clean.

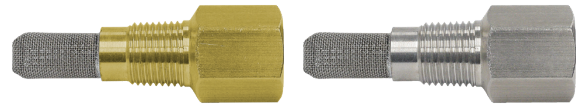

Model X46A Straight

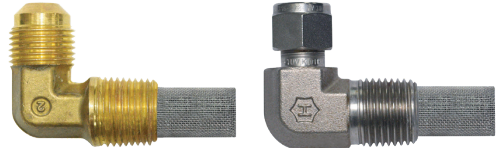

Model X46B Angle

### INSTALLATION

The strainer is designed for use in conjunction with a Cla-Val Main Valve, but can be installed in any piping system where there is a moving fluid stream to keep it clean. When it is used with the Cla-Val Valve, it is threaded into the upstream body port provided for it on the side of the valve. It projects through the side of the Main Valve into the flow stream. All liquid shunted to the pilot control system and to the cover chamber of the Main Valve passes through the Model X46 Flow Clean Strainer.

### INSPECTION

Inspect internal and external threads for damage or evidence of cross-threading. Check inner and outer screens for clogging, embedded foreign particles, breaks, cracks, corrosion, fatigue, and other signs of damage.

### DISASSEMBLY

Do not attempt to remove the screens from the strainer housing.

### CLEANING

After inspection, cleaning of the Model X46 can begin. Water service usually will produce mineral or lime deposits on metal parts in contact with water. These deposits can be cleaned by dipping Model X46 in a 5-percent muriatic acid solution just long enough for deposit to dissolve. This will remove most of the common types of deposits.

**CAUTION: use extreme care when handling acid.** If the deposit is not removed by acid, then a fine grit (400) wet or dry sandpaper can be used with water. Rinse parts in water before handling. An appropriate solvent can clean parts used in fueling service. Dry with compressed air or a clean, lint-free cloth.

Protect from damage and dust until reassembled.

### REPLACEMENT

If there is any sign of damage, or if there is the slightest doubt that the Model X46 Flow Clean Strainer may not afford completely satisfactory operation, replace it. Use Inspection steps as a guide. Neither inner screen, outer screen, nor housing is furnished as a replacement part. Replace Model X46 Flow Clean Strainer as a complete unit.

When ordering replacement Flow-Clean Strainers, it is important to determine pipe size of the tapped hole into which the strainer will be inserted (refer to column A or F), and the size of the external connection (refer to column B or G).



## Dimensions (in Inches)

X46 Straight Type A (In Inches)						
A (NPT)	C (NPT)	D	E	F	G	I
1/8	1/8	1-3/4	3/4	1/2	1/2	1/4
1/4	1/4	2-1/4	1	3/4	3/4	3/8
3/8	3/8	2-1/2	1	7/8	7/8	1/2
3/8	1/2	2-1/2	1-1/4	1/2	7/8	3/4
1/2	1/2	3	1-1/4	1	1-1/8	3/4
3/8	3/4	3-3/8	2	1/2	1	7/8
3/4	3/4	4	2	1	1-1/2	7/8
3/8	1	4-1/4	2-3/4	1/2	1-3/8	7/8
1	1	4-1/2	2-3/4	1-1/4	1-3/4	7/8
1/2	1	4-1/4	2-3/4	1/2	1-3/8	7/8

X46 Angle Type B (In Inches)					
B (NPT)	C (SAE)	D	E	H	I
1/8	1/4	1-3/8	5/8	7/8	1/4
1/4	1/4	1-3/4	3/4	1	3/8
3/8	1/4	2	7/8	1	1/2
3/8	3/8	1-7/8	7/8	1	1/2
1/2	3/8	2-3/8	1	1-1/4	5/8

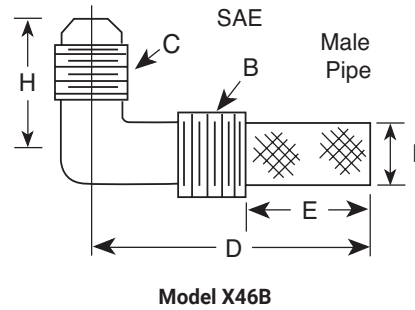
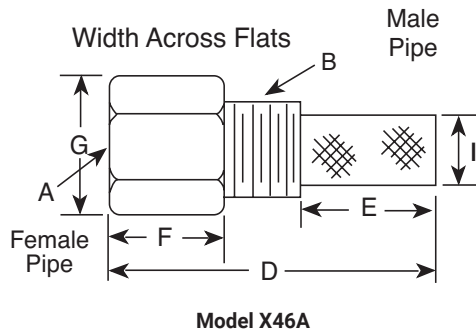

## When Ordering, Please Specify

1. Catalog number X46
2. Straight or Angel Type
3. Size inserted into and size connection
4. Materials



AK	07-10-08	AK	08-14-08	PC	10-1-2008	<b>CLA-VAL CO.</b> NEWPORT BEACH, CALIFORNIA	CATALOG NO.	DRAWING NO. <b>67783</b>	REV <b>BD</b>				
	TYPE OF VALVE AND MAIN FEATURES						CK2 COCK/BALL VALVE						
							DESIGN	DRAWN	MGR	4-02-80			
								CHK'D	KD	4-03-80			
								APV'D	CH	4-07-80			
SCALE: NONE													
CLA-VAL PART NO. AND MATERIAL													
BRONZE WITH HANDLE	STEEL WITH HANDLE	IRON WITH HANDLE	316 SST WITH HANDLE	316 SST W/ LOCKING HANDLE	BRONZE WITH HANDLE	MONEL WITH HANDLE	MONEL W/ LOCKING HANDLE	SIZE "NPT"					
67783-01K*	-09C	-17F	-25J SUPSD BY-26G		-41F SUPSD BY-01K			1/8"					
-02H	-10A	-18D	-26G	-51E SUPSD BY-26G -52C	-42D SUPSD BY-02H	-55F		1/4"					
-03F * -59H***	-11J	-19B	-27E	-46E SUPSD BY-27E -53A	-45G -57B**	-48A SUPSD BY-49J	-63K	3/8"					
-04D -60F***	-12G	-20K	-28C	-54J	-43B SUPSD BY-04D	-49J	-62B	1/2"					
-05A -61D***	-13E	-21H	-29A	-64H	-44K SUPSD BY-05A	-56D		3/4"					
-06J	-14C	-22F	-30J			-58K		1"					
-07G	-15K	-23D	-31G					1 1/4"					
-08E	-16H	-24B	-32E					1 1/2"					
-50G			-47C					2"					
<p>* SEE ENGINEERING APPROVED VENDORS TABLE (SHEET 2 OF 2).</p> <p>** HAMMOND VALVE 8501 ONLY.</p> <p>*** WILKINS CK2 (SEE SHEET 2 OF 2)</p>													

"THIS DRAWING IS THE PROPERTY OF CLA-VAL CO. AND SAME AND COPIES MADE THEREOF, IF ANY, SHALL BE RETURNED TO IT UPON DEMAND. DELIVERY AND DISCLOSURE HEREOF ARE SOLELY UPON CONDITION THAT THE SAME SHALL NOT BE USED, COPIED OR REPRODUCED, NOR SHALL THE SUBJECT HEREOF BE DISCLOSED IN ANY MANNER TO ANYONE FOR ANY PURPOSE, EXCEPT AS HEREIN AUTHORIZED, WITHOUT PRIOR WRITTEN APPROVAL OF CLA-VAL CO. THIS DRAWING IS SUBMITTED CONFIDENTIALLY AND MAY NOT BE USED IN THE MANUFACTURE OF ANY MATERIAL OR PRODUCT OTHER THAN SUCH MATERIALS AND PRODUCTS FURNISHED TO CLA-VAL CO. WHETHER OR NOT THE EQUIPMENT OR INFORMATION SHOWN HEREON IS PATENTED OR OTHERWISE PROTECTED, FULL TITLE AND COPYRIGHTS, IF ANY, IN AND TO THIS DRAWING AND/OR INFORMATION DELIVERED OR SUBMITTED ARE FULLY RESERVED CLA-VAL CO."



# Model CV FLOW CONTROL

## DESCRIPTION

The CV Control is an adjustable restriction which acts as a needle valve when flow is in the direction of the stem. When flow is in the reverse direction, the port area opens fully to allow unrestricted flow. When installed in the control system of a Cla-Val automatic valve, it can be arranged to function as either an opening or closing speed control.

## OPERATION

The CV Flow Control permits full flow from port A to B, and restricted flow in the reverse direction. Flow from port A to B lifts the disc from seat, permitting full flow. Flow in the reverse direction seats the disc, causing fluid to pass through the clearance between the stem and the disc. This clearance can be increased, thereby increasing the restricted flow, by screwing the stem out, or counter-clockwise. Turning the stem in, or clockwise reduces the clearance between the stem and the disc, thereby reducing the restricted flow.

## INSTALLATION

Install the CV Flow Control as shown in the valve schematic. All connections must be tight to prevent leakage.

## DISASSEMBLY

Follow the sequence of the item numbers assigned to the parts in the cross sectional illustration for recommended order of disassembly.

Use a scribe, or similar sharp-pointed tool to remove O-ring from the stem.

## INSPECTION

Inspect all threads for damage or evidence of cross-threading. Check mating surface of seat and valve disc for excessive scoring or embedded foreign particles. Check spring for visible distortion, cracks and breaks. Inspect all parts for damage, corrosion and cleanliness.

## CLEANING

After disassembly and inspection, cleaning of the parts can begin. Water service usually will produce mineral or lime deposits on metal parts in contact with water. These deposits can be cleaned by dipping the parts in a 5-percent muriatic acid solution just long enough for deposits to dissolve. This will remove most of the common types of deposits. **CAUTION: Use extreme care when handling acid.** If the deposit is not removed by acid, then a fine grit (400) wet or dry sandpaper can be used with water. Rinse parts in water before handling. An appropriate solvent can clean parts used in fueling service. Dry with compressed air or a clean, lint-free cloth. Protect from damage and dust until reassembled.

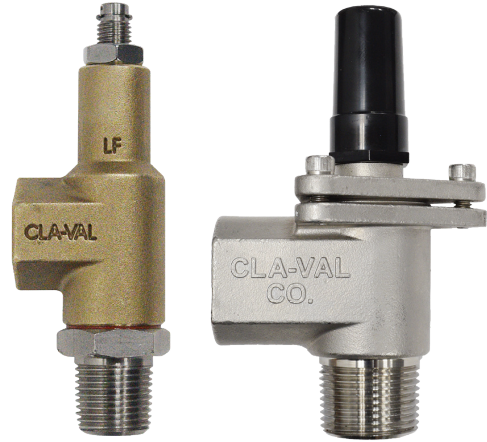

## REPAIR AND REPLACEMENT

Minor nicks and scratches may be polished out using a fine grade of emery or crocus cloth; replace parts if scratches cannot be removed.

Replace O-ring packing and gasket each time CV Flow Control is overhauled.

Replace all parts which are defective. Replace any parts which create the slightest doubt that they will not afford completely satisfactory operation. Use Inspection steps as a guide.

## REASSEMBLY

Reassembly is the reverse of disassembly; no special tools are required.

## TEST PROCEDURE

No testing of the flow Control is required prior to reassembly to the pilot control system on Cla-Val Main Valve.





### 3/8" CV Flow Control

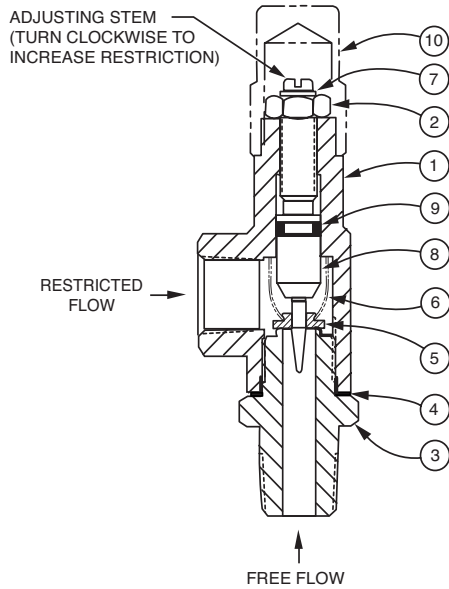

Item No.	Description	QTY
1	Housing	1
2	Nut, Jam	1
3	Seat	1
4	Gasket	1
5	Disc	1
6	Spring	1
7	Ring, Retaining	1
8	Stem	1
9	O-Ring	1
10	Cap (SS only)	1

### 1/2", 3/4", and 1" CV Flow Control

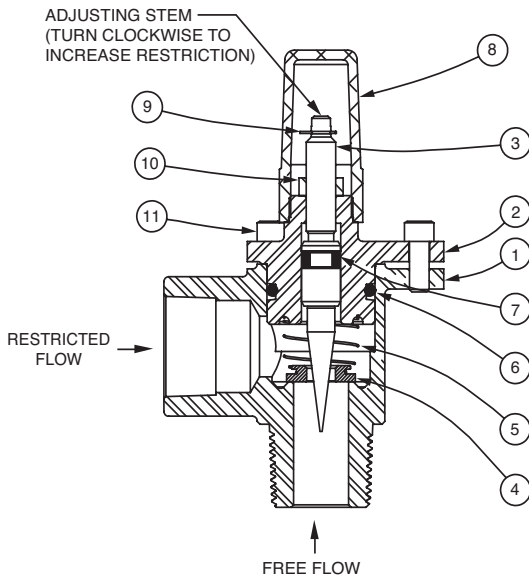

Item No.	Description	QTY
1	Body	1
2	Cover	1
3	Stem	1
4	Disc	1
5	Spring	1
6	O-Ring	1
7	O-Ring	1
8	Cap	1
9	Ring, Retaining	1
10	Nut, Jam	1
11	Socket Head Cap Screw	3

### When Ordering, Please Specify

1. All Nameplate/Stamped data
2. Item Number
3. Description
4. Material





# MODEL X144 e-FlowMeter

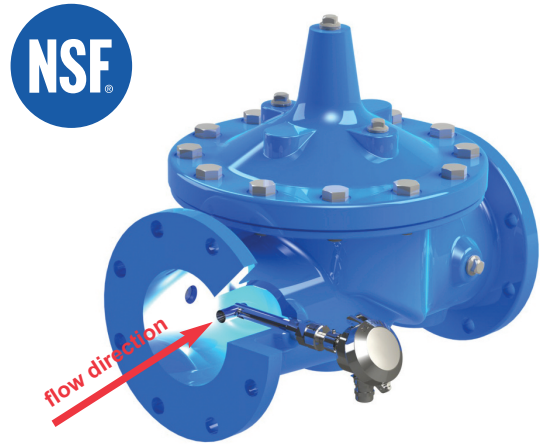
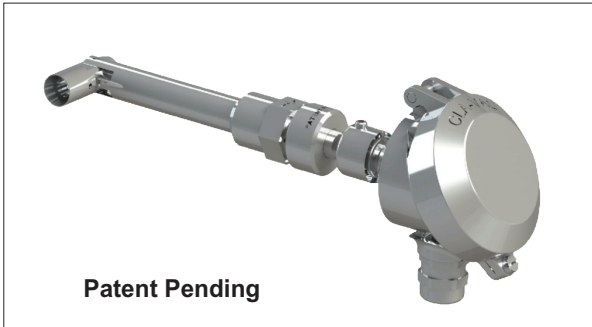

Installation view of the X144 e-FlowMeter  
**Note: Consult Factory for Angle Pattern Applications**

## Frequency Measurement

The X144 e-FlowMeter uses the vortex shedding method to measure flow. The meter is inserted into the inlet tapping of the valve and the measurement cylinder is oriented parallel to the direction of flow. The flow enters the measurement cylinder where it encounters the bluff body, generating vortices, which in turn, deflects off the piezoelectric sensor.

The sensor counts the vortices and communicates the data to the meter's integral circuit board. The flow data signal is converted to 4-20mA, or transistor (NPN) pulse, depending on the desired application.

- The e-FlowMeter can be retrofitted to an existing Cla-Val Automatic Control Valve or factory assembled on a new valve
- Alleviates the need for an in-line meter and the associated installation costs
- IP68 Submersible (verified by independent lab testing)
- Provides flow data with accuracy +/- 2% of Full Scale
- Mounts on either inlet body tapping of the Cla-Val Control Valve
- Stainless Steel Construction
- 4-20mA Loop Powered
- Plug-and-Play Metering
- No Moving Parts
- Independent laboratory tested:
  - Utah State University,
  - Imperial College - London



The Cla-Val Model X144 e-FlowMeter is a vortex shedding insertion flow meter designed to be retrofitted into a Cla-Val Automatic Control Valve to provide accurate flow measurement data without the need to install a separate meter.

Configured for installation in the inlet tapping of a Cla-Val Automatic Control Valve, the X144 can be used in valves directly downstream of a flow disturbance such as elbows, valves or a reducer. (See page 2 for installation guidelines)

The X144 e-FlowMeter employs an innovative swivel mechanism which allows the meter to be inserted into tappings as small as 1/2-inch. For applications involving installation in close proximity to pump discharge, please consult factory with details.

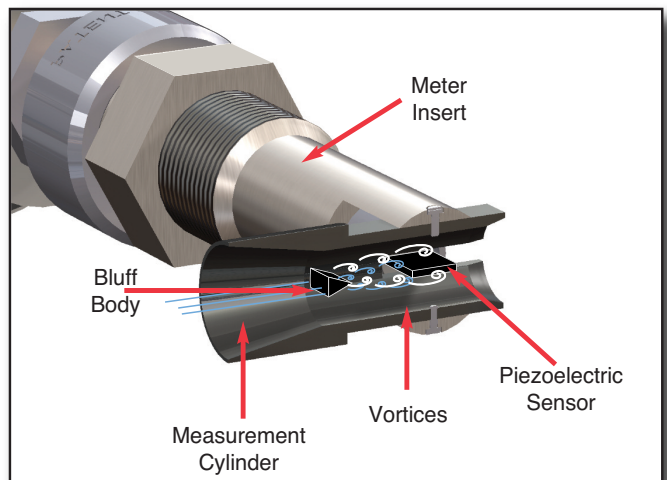

# Installation Guidelines and Typical Applications

## Installation Locations

For optimum performance, it is recommended that the valve in which the X144 e-FlowMeter is installed be located as shown below.

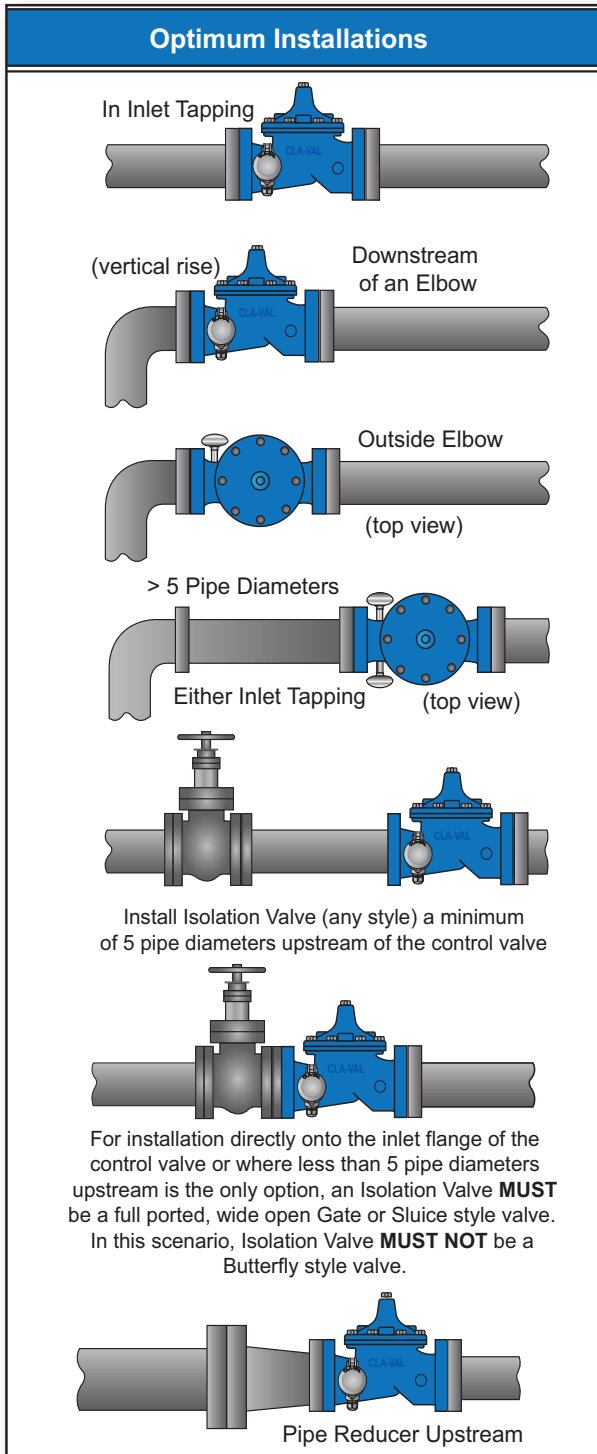

### Notes:

- Consult factory for other installation configurations
- Do not use butterfly valves as isolation valves adjacent to X144 installations

## Information Transmission

The X144 e-FlowMeter measures and transmits flow information via a 4-20mA signal to SCADA equipment.

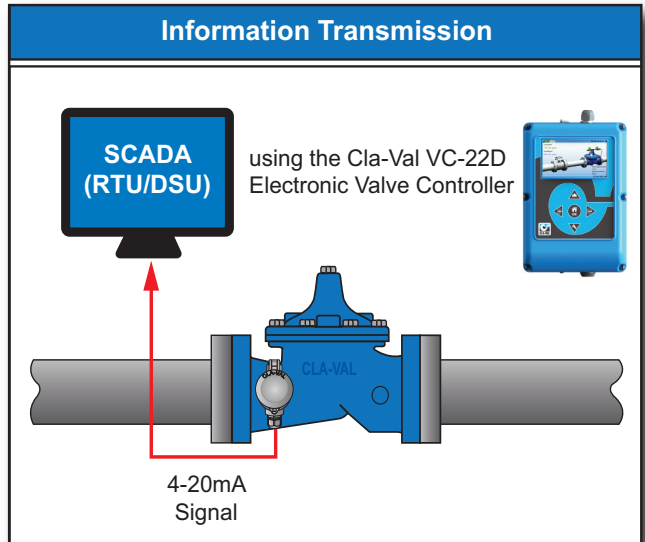

## Data Acquisition and Storage using Cla-Val Power Generator

- The X144 e-FlowMeter connects to most commercially available loggers with the choice of 4-20mA or pulse output.
- The X145 e-Display is an ideal companion to the X144 e-flowMeter, providing access to real-time data
- Both the e-Display and the e-FlowMeter can be powered by the Cla-Val X143MP Micro-Turbine Power Generator

To learn more about the X143MP Power Generator, visit [www.cla-val.com/electronic-products](http://www.cla-val.com/electronic-products)

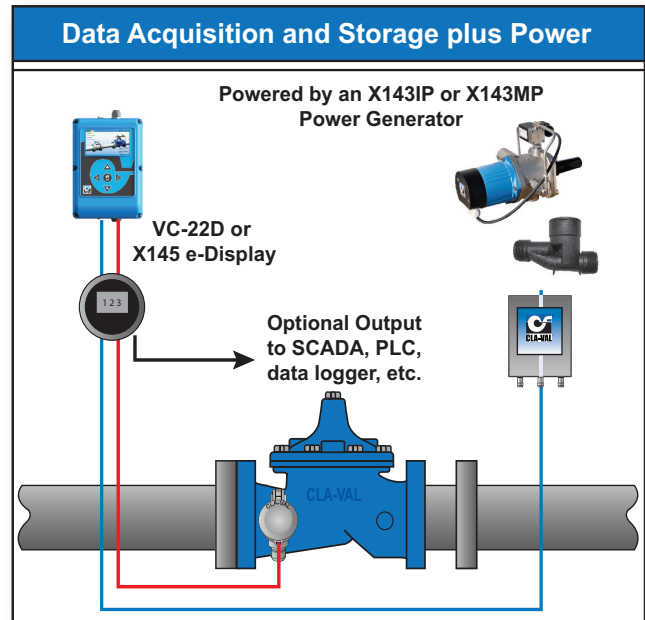

## X144 Dimensions

X144 Sizes		1	2	3	4
Full Port Valve Sizes		2*, 2-1/2, 3	4, 6	8, 10	12, 14, 16, 18, 20, 24, 30**
Reduced Port Valve Sizes		4	6, 8	10, 12	14, 16, 18, 20, 24**
Overall Length (in inches)	A	8.85	9.45	13.18	17.91
Insertion Length (in inches)	B	2.3	2.8	6.8	11.25
Pipe Thread (NPT)	C	1/2"	3/4"	1"	1"
Overall Width (in inches)	D	3.25	3.25	3.25	3.25

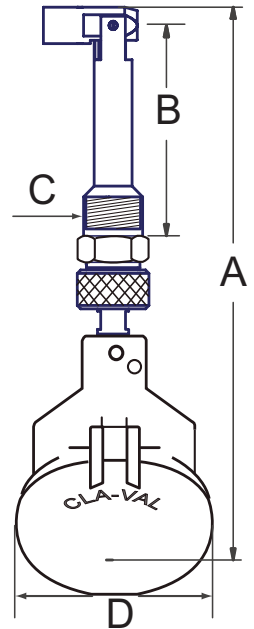

\*2" X144 e-FlowMeter may be installed on new valves only

\*\* Consult factory for larger applications

**X144 e-FlowMeter Operational Flow Range = from 1 ft/s to 20 ft/s**

## Typical Performance

### X144 e-FlowMeter vs. Mag Meter

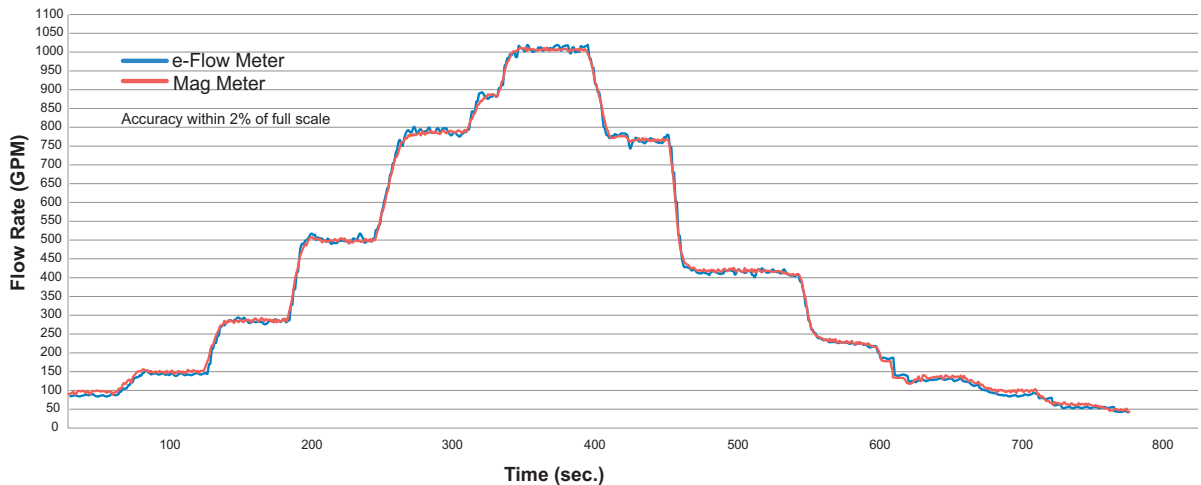

## Options

- Remote Mounted Display - X145 e-Display
- Field Optimization using e-FlowMeter Customer Software
- Pulsed output proportional to flow rate for low power consumption



**X145 e-Display**

## Product Details

### Insertion Tool and Locking Ring

- Required for installation
- Tool allows the proper installation and alignment of the bluff body to be parallel to upstream flow.

### Power Requirement

- 12/24 VDC, 0.7 Watts minimum.

### X144 e-Flow Meter Sizing

- The X144 threads directly into the inlet tapping of a Cla-Val Control Valve. The size of the e-FlowMeter is dependent on the specific valve size for which it has been calibrated - no additional fittings are required.  
**See dimension chart on previous page.**

### Cabling

- The unit is supplied with 20 feet of shielded cable.

### Maximum Operating Pressure : 400 PSI

### X144 e-FlowMeter Analog Range (4-20mA Scaling): Factory Settings

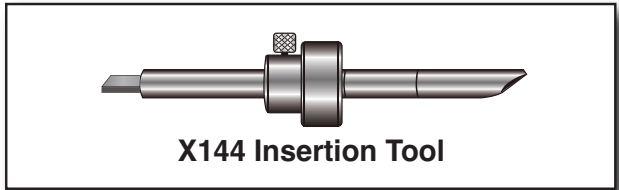

Port Style	Line Size inches (mm)	**2" (50) (100-49 Body)	2-1/2" (65)	3" (80)	4" (100)	6" (150)	8" (200)	10" (250)	12" (300)	14" (350)	16" (400)	18" (450)	20" (500)	24" (600)	30" (750)
Full Port Valves 4mA = 0 (GPM - l/s)	20mA Range (GPM)	260	375	575	1000	2250	3900	6000	8750	10500	14000	17500	22000	31000	52000
	20mA Range (l/s)	16.4	23.7	36.3	63.1	140	245	380	550	660	880	1100	1390	1950	3280
Full Port Pulse Weight*	Gal/Pulse	5	6.5	9.5	17	38	65	100	150	175	235	290	365	515	865
	l/Pulse	19	25	36	65	145	245	380	565	660	890	1100	1380	1950	3275
Reduced Port Valves 4mA = 0 (GPM- l/s)	20mA Range (GPM)	not available			675	1600	2900	4500	5650	7750	9350	Consult Factory			
	20mA Range (l/s)				42.5	100	180	285	355	490	590				
Reduced Port Valves Pulse Weight*	Gal/Pulse				11.5	26	48	75	95	130	155				
	l/Pulse				44	99	180	285	360	495	585				

\* Note: \* Pulse Width = 250ms

\*\*2" X144 e-FlowMeter may be installed on new valves only



E-X144 (R 09/2017)

## CLA-VAL

1701 Placentia Avenue • Costa Mesa, CA 92627

800-942-6326 • Fax: 949-548-5441 • Web Site: [cla-val.com](http://cla-val.com) • E-mail: [info@cla-val.com](mailto:info@cla-val.com)

### CLA-VAL CANADA

4687 Christie Drive  
Beamsville, Ontario  
Canada L0R 1B4  
Phone: 905-563-4963  
Fax: 905-563-4040  
E-mail [sales@cla-val.ca](mailto:sales@cla-val.ca)

### CLA-VAL EUROPE

Chemin des Mésanges 1  
CH-1032 Romanel/  
Lausanne, Switzerland  
Phone: 41-21-643-15-55  
Fax: 41-21-643-15-50  
E-mail: [cla-val@cla-val.ch](mailto:cla-val@cla-val.ch)

### CLA-VAL UK

Dainton House, Goods Station Road  
Tunbridge Wells  
Kent TN11 2 DH England  
Phone: 44-1892-514-400  
Fax: 44-1892-543-423  
E-mail: [info@cla-val.co.uk](mailto:info@cla-val.co.uk)

### CLA-VAL FRANCE

Porte du Grand Lyon 1  
ZAC du Champ du Périer  
France - 01700 Neyron  
Phone: 33-4-72-25-92-93  
Fax: 33-4-72-25-04-17  
E-mail: [cla-val@cla-val.fr](mailto:cla-val@cla-val.fr)

©COPYRIGHT CLA-VAL 2017 Printed in USA Specifications subject to change without notice.



# X144 e-FlowMeter

## Quick Start Installation & Removal Instructions

### X144 e-FlowMeter Included Hardware

**1** Complete e-FlowMeter Assembly

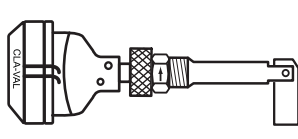

patent pending

**2** Complete Installation Kit

a) Insertion Tool Score Marks



b) Thumb Set Screw Locking Collar

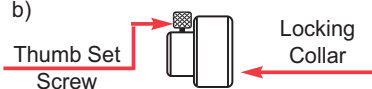

#### Parts List

- 1) X144 e-FlowMeter Assembly with 20 foot cable
- 2) Installation Kit containing:
  - a) Insertion Tool
  - b) Locking Collar with Thumb Set Screw (a and b come assembled)

#### Installation Kit Part Numbers:

**Small (2.5" - 6" + 8" reduced Port): 208450-21K**  
**Large (8" Full Port - 16") : 208450-20A**

### Step-By-Step X144 e-FlowMeter Installation Instructions

**1**

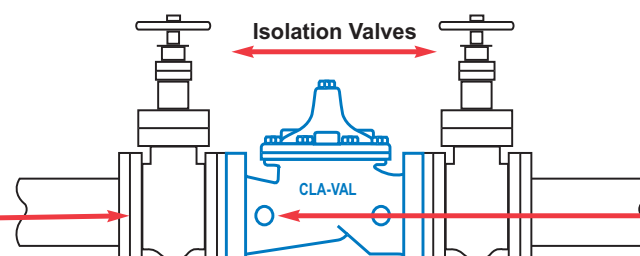

Isolation Valves

flow

CLA-VAL

**Step 1: Take necessary safety precautions**

- Isolate the control valve using main line isolation valves
- Bleed pressure from valve before removing body plug
- Remove an inlet body plug

**NOTE: If both inlet body tappings are used for the pilot system, consult factory for correct modification instructions.**

**2**

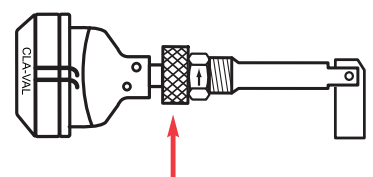

**Step 2A:**  
Loosen Knurled Lock Nut on e-FlowMeter Assembly

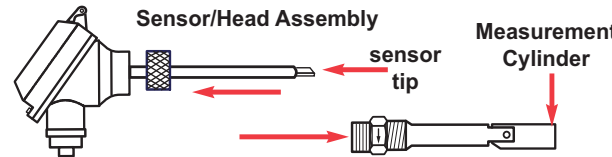

Sensor/Head Assembly

Measurement Cylinder

sensor tip

Threaded Swivel Insert

**Step 2B:** Pull apart. Straighten Measurement Cylinder by hand. Set aside Sensor/Head in safe location, protecting sensor tip

**3**

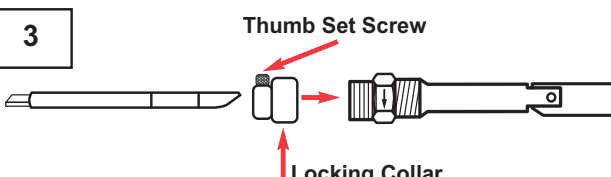

Thumb Set Screw

Locking Collar

**Step 3A:** Screw Locking Collar on straight threads. Insert angled end of provided tool as shown, until it stops

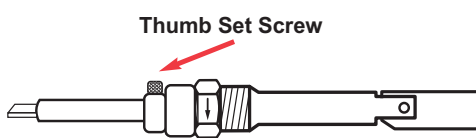

Thumb Set Screw

**Step 3B:** Tighten Thumb Set Screw

**4**

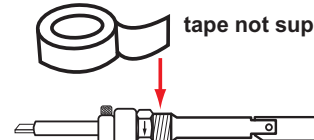

tape not supplied

**Step 4:** Apply Teflon® tape to NPT Threads

- Check threads on valve
- Use thread chasing tool (not supplied), if necessary





# X144 e-FlowMeter

## Quick Start Installation & Removal Instructions

### Step-By-Step X144 e-FlowMeter Installation Instructions (continued)

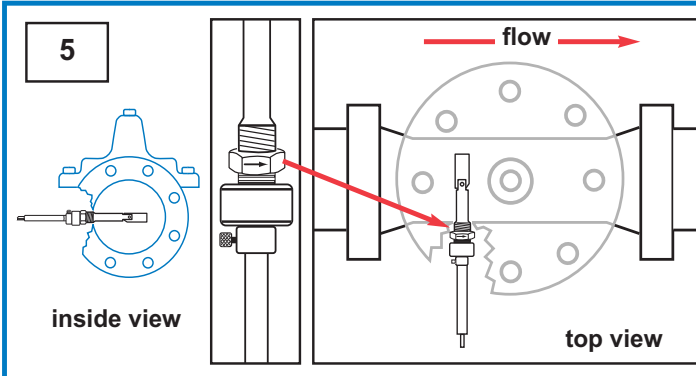

**Step 5:** Insert straightened Swivel Insert/Measurement Cylinder Assembly into valve, orient arrow on wrench flat to point downstream

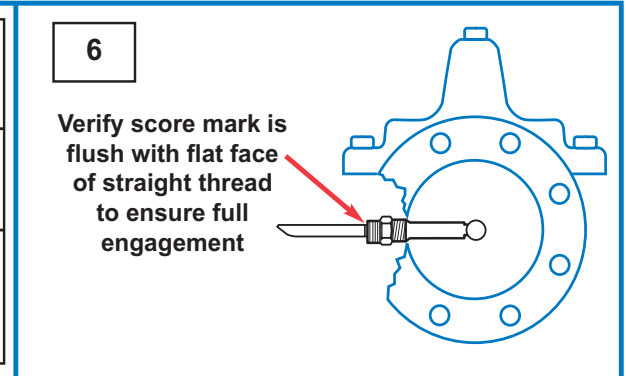

**Step 6:** Loosen Thumb Set Screw. Remove Locking Collar from tool. Remove tool and re-insert opposite end into Swivel Assembly. Engage the tool and push firmly to orient Measurement Cylinder 90° into flow path

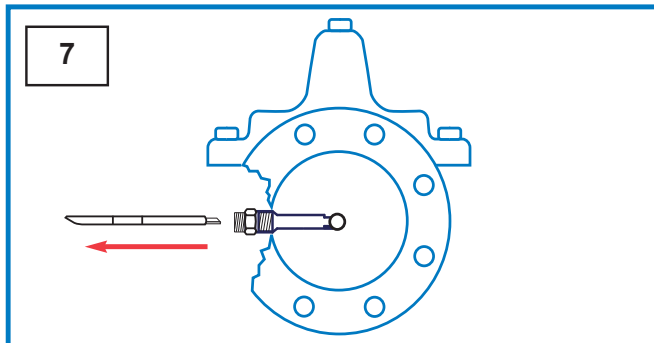

**Step 7:** Remove tool from Threaded Swivel Insert

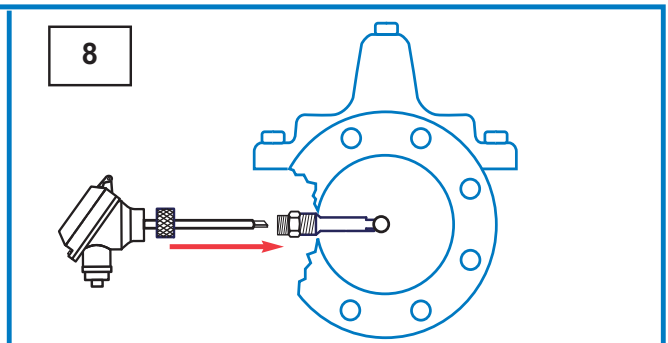

**Step 8:** Insert tip of e-FlowMeter Sensor/Head Assembly into Threaded Swivel Insert

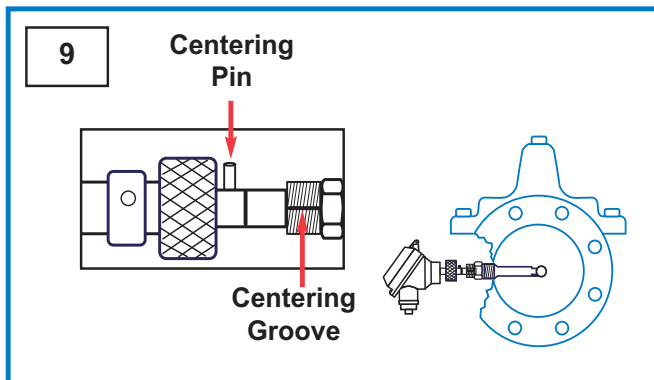

**Step 9:** Line-Up Centering Groove on straight threads with Centering Pin; push to seat o-ring

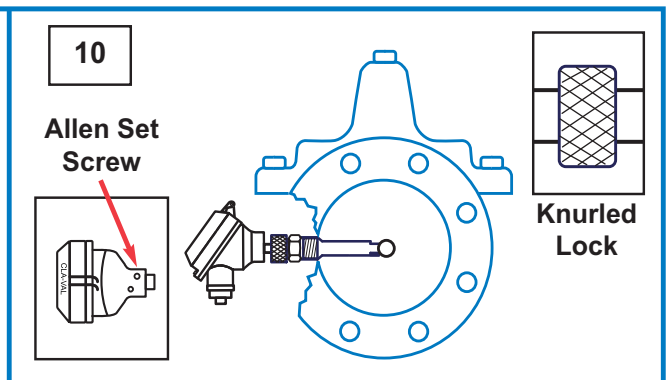

**Step 10:** **HAND TIGHTEN** Knurled Lock onto straight threads. Tighten Allen Set Screw with M3 Allen Wrench to lock Sensor Head Assembly.

Proceed in accordance with Wiring Diagram



# X144 e-FlowMeter

## Quick Start Installation & Removal Instructions

### Standard Wiring

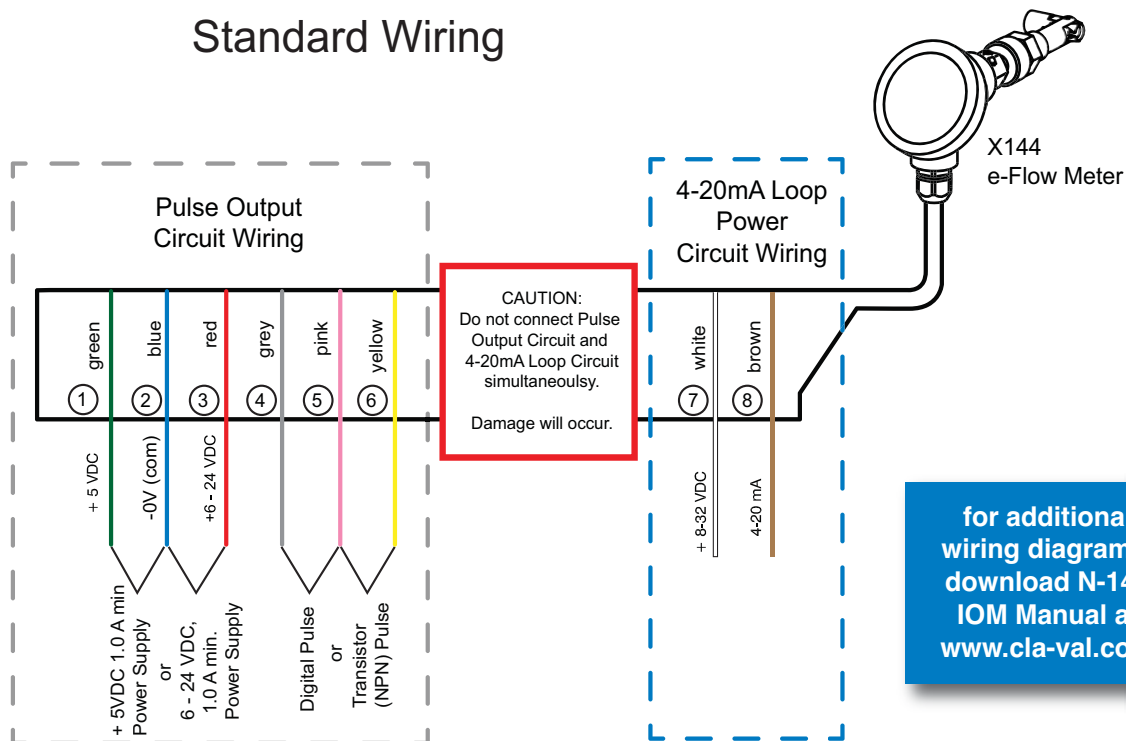

### Step-By-Step X144 e-FlowMeter Removal Instructions

1

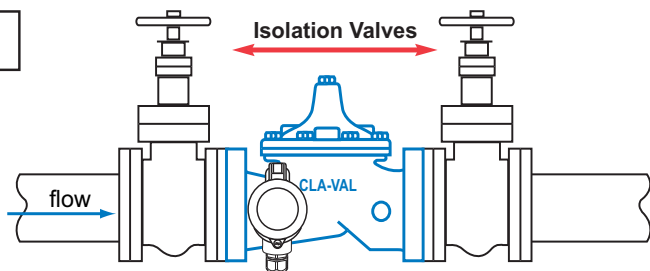

#### Step 1: Take necessary safety precautions

- Isolate the control valve using main line isolation valves
- Bleed pressure from valve before removing the e-FlowMeter
- Disconnect power to all electronic devices on valve, including e-FlowMeter

2

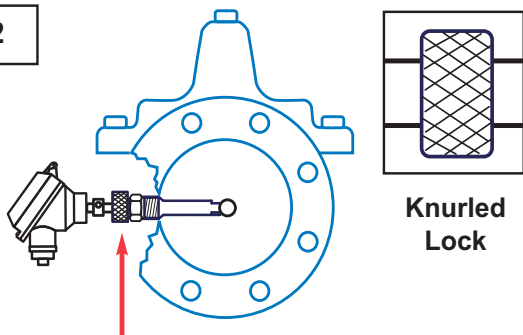

- Step 2:** After isolating the valve, bleeding pressure and disconnecting electronic devices, hand loosen the Knurled Lock from straight threads

call 800.942.6326 for assistance  
or log-on to  
[www.cla-val.com](http://www.cla-val.com) for more information



# X144 e-FlowMeter

## Quick Start Installation & Removal Instructions

### Step-By-Step X144 e-FlowMeter Removal Instructions (continued)

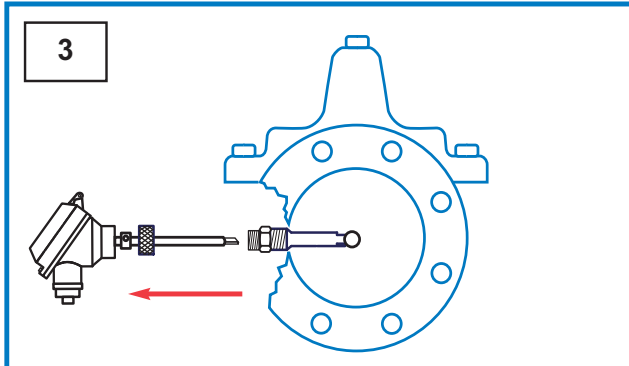

#### Step 3:

- Remove the e-FlowMeter Sensor/Head Assembly by pulling straight outward, being careful not to hit the sensor tip on the Threaded Swivel Insert tube
- Set Sensor/Head Assembly aside, taking care to protect the sensor tip

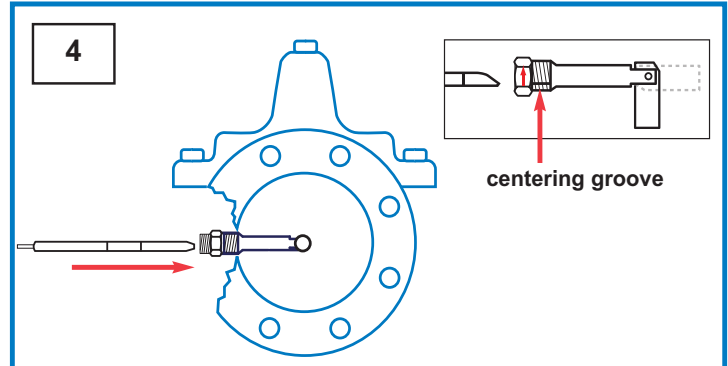

#### Step 4:

- Orient the Installation Tool so that the bevel is facing downstream, away from the centering groove as shown in detail drawing, and insert into the Threaded Swivel Insert

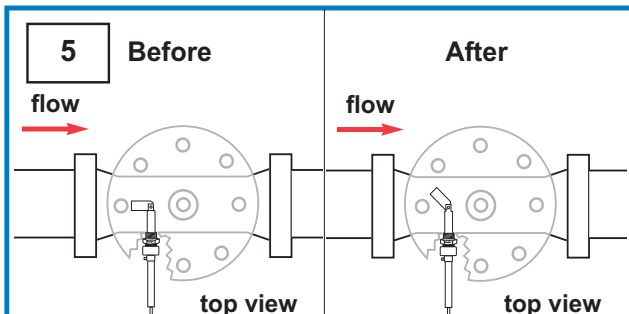

#### Step 5:

- Once inserted into the Threaded Swivel Insert tube, the Installation Tool will engage the top face of the Measurement Cylinder and force it to the 45° position, as shown above



#### Step 6:

- Slide Installation Tool straight out, then rotate 180° so that the bevel is facing upstream of the valve, which is now facing the same direction of the centering groove, see above
- The lip of the Installation Tool will engage the inside of the Measurement Cylinder as shown in photo

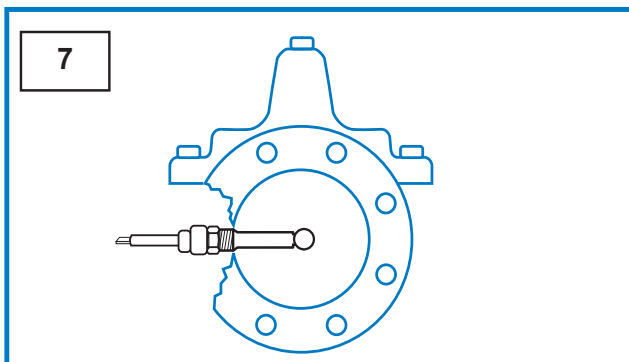

#### Step 7:

- Once engaged, use light force to straighten the measurement cylinder, and then secure the Installation Tool in place with Locking Collar in locked position

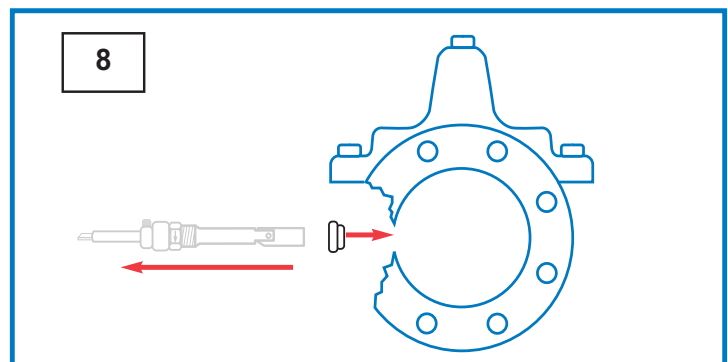

#### Step 8:

- Remove Threaded Swivel Insert from the valve tapping with the Measurement Cylinder straightened
- Insert body plug into tapping while servicing the e-FlowMeter



— MODEL — **X141**

# Cla-Val Gauge Option

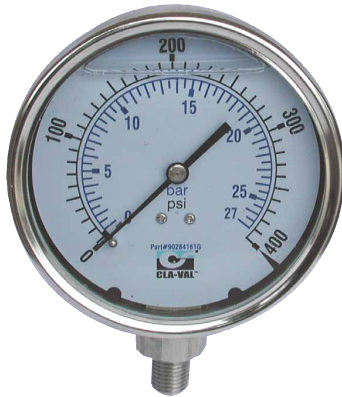

Model X141  
4" Pressure Gauge

- Liquid-Filled
- Dual Scale (PSI / BAR)
- Long Life Stainless Steel Construction
- Tamper-Resistant Design
- 2 1/2" and 4" Diameter Sizes
- Isolation Valve Included

The Cla-Val Model X141 Pressure Gauge Option consists of glycerin-filled pressure gauges with the Cla-Val Logo and 1/4" CK2 Bronze Isolation Valves on the main valve inlet and outlet. Cla-Val gauges are waterproof, shock resistant, and fully enclosed with a stainless steel case and bronze wetted parts. Ambient temperature ratings are -4 Degrees F to +140 Degrees F (-20 Degrees C to +60 Degrees C).

All gauges have dual scale (PSI/BAR) and are supplied with a 1/4" NPT bottom connection. Model X141 gauges are available installed on new valves and must be specified on the customer Purchase Order. Consult factory for other available materials.

## Available Pressure Ranges

X141 Gauge Assembly (2 1/2" Diameter Dial)

Pressure Range*	Part Number
0 - 60 psi	20534301A
0 - 100 psi	20534302K
0 - 200 psi	20534303J
0 - 300 psi	20534304H
0 - 400 psi	20534305G

X141 Gauge Assembly (4" Diameter Dial)

Pressure Range*	Part Number
0 - 60 psi	20534306F
0 - 100 psi	20534307E
0 - 200 psi	20534308D
0 - 300 psi	20534309C
0 - 400 psi	20534310K

## Typical X141 Installation



## Typical Installation with two X141 Gauges

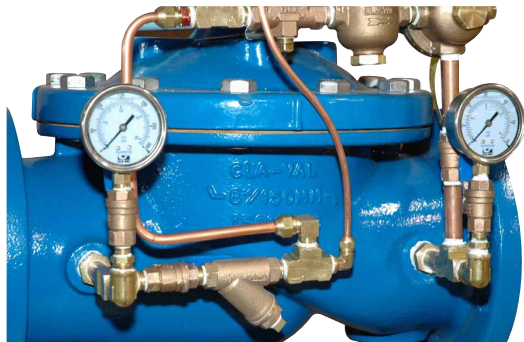

\*Specify desired pressure range and valve location (inlet or outlet) on order.





# Model X101D

## VALVE POSITION INDICATOR

PARTS LIST

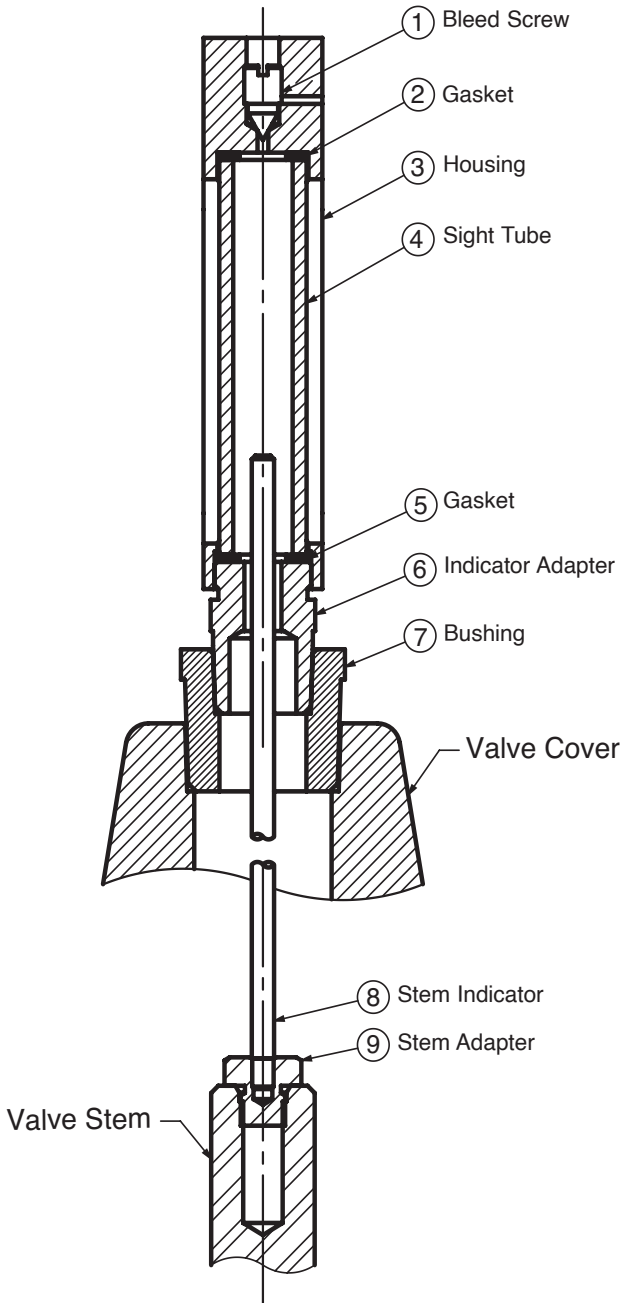

Item No.	Description	Material
1	Bleed Screw	Stainless Steel
2	Gasket	Buna-N®
3	Housing	Stainless Steel
4	Sight Tube	Pyrex
5	Gasket	Buna-N®
6	Indicator Adapter	Stainless Steel
7	Bushing	Stainless Steel
8	Stem Indicator	Stainless Steel
9	Stem Adapter	Stainless Steel

### When Ordering, Please Specify

1. All Nameplate data
2. Item Number
3. Description
4. Material





# X43 Strainer

ITEM	DESCRIPTION	MATERIAL
1	Pipe Plug	Stainless Steel
2	Strainer Plug	Stainless Steel
3	Gasket	Fiber
4	Screen	Stainless Steel
5	Body	Stainless Steel

No parts available. Replacement assembly only.

Standard 60 mesh pilot system strainer for fluid service.

Size	Stock Number
3/8 x 3/8	8850604D

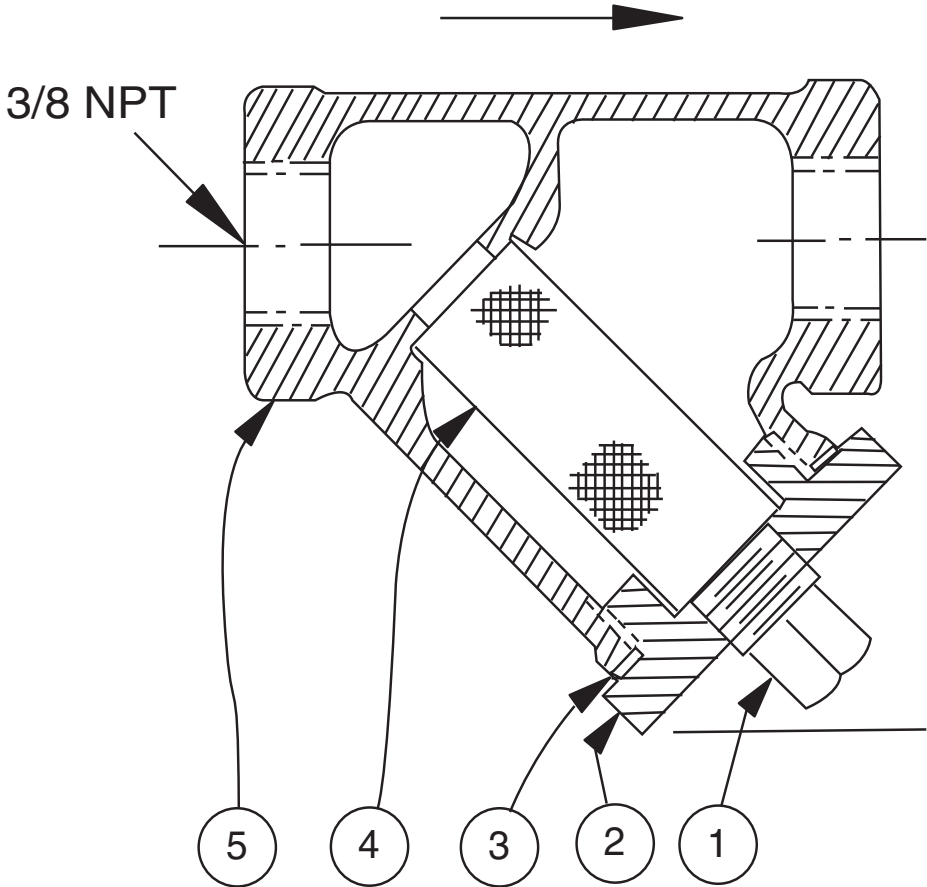



# Model Repair Kits

## Model 100-01 Hytrol Main Valve

BUNA-N MATERIAL				
	RUBBER KIT STOCK #	REPAIR KIT STOCK #	REBUILD ASSEMBLY STOCK #	STUD & NUT KIT STOCK #
3/8"	9169801K		21176614B	21176633J
1/2"	9169802H	21176602F	21176615A	21176634H
3/4"	9169802H	21176602F	21176615A	21176634H
1" Non-Guided	9169803F	21176601G	21176616K	21176636F
1"	9169804D	21176603E	21176617J	21176636F
1 1/4"	9169804D	21176603E	21176617J	21176636F
1 1/2"	9169804D	21176603E	21176617J	21176636F
2"	9169805A	21176608K	21176618H	21176637E
2 1/2"	9169811J	21176609J	21176619G	21176638D
3"	9169812G	21176604D	21176620D	21176639C
4"	9169813E	21176605C	21176621C	21176640K
6"	9169815K	21176606B	21176622B	21176641J
8"	9817901D	21176607A	21176623A	21176642H
10"	9817902B	21176610F	21176654C	21176643G
12"	9817903K	21176611E	21176625J	21176644F
14"	9817904H	21176612D	21176626H	21176645E
16"	9817905E	21176613C	21176627G	21176645E

## Model 100-20 Hytrol Main Valve

BUNA-N MATERIAL				
	RUBBER KIT STOCK #	REPAIR KIT STOCK #	REBUILD ASSEMBLY STOCK #	STUD & NUT KIT STOCK #
3"	9169805A	21176608K	21176618H	21176637E
4"	9169812G	21176604D	21176620D	21176639C
6"	9169813E	21176605C	21176621C	21176640K
8"	9169815K	21176606B	21176622B	21176641J
10"	9817901D	21176607A	21176623A	21176642H
12"	9817902B	21176610F	21176624K	21176643G
14"	9817903K	21176611E	21176625J	21176644F
16"	9817903K	21176611E	21176625J	21176644F

## Model 100-30 Hytrol Main Valve

BUNA-N MATERIAL		
	RUBBER KIT STOCK #	REBUILD ASSEMBLY STOCK #
2 1/2"	21112704H	21235401C
3"	21112702K	21235402B
4"	21112703J	21235403A
6"	27496886J	21235404K
8"	21112701A	21235405J
10"	CF	21235406H

- Rubber Kit Includes:** Diaphragm, Disc, Spacer Washers. **Model 100-30 also includes:** Stem O-Ring, Seal, Bearing O-Ring.
- Repair Kit Includes:** Diaphragm, Disc, Spacer Washers, Epoxy Coated Disc Retainer, Epoxy Coated Diaphragm Washer, Protective Washer
- Rebuild Assembly Includes:** Diaphragm, Disc, Spacer Washers, Epoxy Coated Disc Retainer, Epoxy Coated Diaphragm Washer, Protective Washer, Stainless Steel Bolts & Washers (6" & Below), Stainless Steel Studs, Nuts, & Washers (8" & Above), Stem, Stem Nut, Disc Guide, Standard Cover Spring, Cover Washer. **Model 100-30 also includes:** Upper and Lower Stem and Stem Nut, Stem O-Ring, Seal, Lower Spring, PU Bearing, Bearing O-Ring, Bearing Retainer Ring.
- Stud & Nut Kit Includes:** Stainless Steel Bolts & Washers (6" & Below), Stainless Steel Studs, Nuts, & Washers (8" & Above)



**Repair Kits for 100-02/100-21 Powertrol and 100-03/100-22 Powercheck Main Valves**

**For:** Powertrol and Powercheck Main Valves—150 Pressure Class Only

**Includes:** Diaphragm, Disc (or Disc Assembly) and O-rings and full set of spare Spacer Washers.

Valve Size	Kit Stock Number		Valve Size	Kit Stock Number	
	100-02			100-02 & 100-03	100-21 & 100-22
3/8"	9169901H		2 1/2"	9169910J	N/A
1/2" & 3/4"	9169902F		3"	9169911G	9169905J
1"	9169903D		4"	9169912E	9169911G
1 1/4" & 1 1/2"	9169904B		6"	9169913C	9169912E
2"	9169905J		8"	9169950E	9169913C
			10"	9169939H	9169950E
			12"	9169937B	9169939H

Consult factory for larger sizes

**Repair Kits for 100-04/100-23 Hy-Check Main Valves**

**For:** Hy-Check Main Valves—150 Pressure Class Only

**Includes:** Diaphragm, Disc and O-Rings and full set of spare Spacer Washers.

Valve Size	Kit Stock Number		Valve Size	Kit Stock Number	
	100-04	100-23		100-04	100-23
4"	20210901B	N/A	12"	20210905H	20210904J
6"	20210902A	20210901B	14"	20210906G	N/A
8"	20210903K	20210902A	16"	20210907F	20210905H
10"	20210904J	20210903K	20"	N/A	20210907F
			24"	N/A	20210907F

Consult factory for larger sizes

**Repair Kits for Pilot Control Valves (In Standard Materials Only)**

**Includes:** Diaphragm, Disc (or Disc Assembly), O-Rings, Gaskets or spare Screws as appropriate.

BUNA-N® (Standard Material)				VITON (For KB Controls)	
Pilot Control	Kit Stock Number	Pilot Control	Kit Stock Number	Pilot Control	Kit Stock Number
CDB	9170006C	CFM-7A	1263901K	CDB-KB	9170012A
CDB-30	9170023H	CFM-9	12223E	CRA-KB	N/A
CDB-31	9170024F	CRA (w/bucking spring)	9170001D	CRD-KB (w/bucking spring)	9170008J
CDB-7	9170017K	CRD (w/bucking spring)	9170002B	CRL-KB	9170013J
CDH-2	18225D	CRD (no bucking spring)	9170003K	CDHS-2BKB	9170010E
CDHS-2	44607A	CRD-18	20275401K	CDHS-2FKB	9170011C
CDHS-2B	9170004H	CRD-22	98923G	CDHS-18KB (no bucking spring)	9170009G
CDHS-2F	9170005E	CRL (55F, 55L)	9170007A	102C-KB	1726202D
CDHS-3C-A2	24657K	CRL60/55L-60	9170033G		
CDHS-8A	2666901A	CRL60/55L60 1"	9170042H		
CDHS-18	9170003K	CRL-4A	43413E		
CDS-4	9170014G	CRL-5 (55B)	65755B		
CDS-5	14200A	CRL-5A (55G)	20666E		
CDS-6	20119301A	CRL-18	20309801C		
CDS-6A	20349401C	Universal CRL	9170041K		
CDS-7	20349402B	CV	9170019F		
CDS-7DO	20349403A	X105L (O-ring)	00951E		
CFCM-M1	1222301C	102B-1	1502201F	Buna-N®	
CFM-2	12223E	102C-2	1726201F	CRD Disc Ret. (Solid)	C5256H
CFM-7	1263901K	102C-3	1726201F	CRD Disc Ret. (Spring)	C5255K

**Repair Assemblies (In Standard Materials Only)**

Control	Description	Stock Number
CF1-C1	Pilot Assembly Only	89541H
CF1-CI	Complete Float Control less Ball and Rod	89016A
CFC2-C1	Disc, Distributor and Seals	2674701E
CSM 11-A2-2	Mechanical Parts Assembly	97544B
CSM 11-A2-2	Pilot Assembly Only	18053K
33A 1"	Complete Internal Assembly and Seal	2036030B
33A 2"	Complete Internal Assembly and Seal	2040830J

When ordering, please give complete nameplate data of the valve and/or control being repaired. MINIMUM ORDER CHARGE APPLIES