CLA-VAL

AUTOMATIC CONTROL VALVES

60-11/660-11

Place this manual with personnel responsible
for maintenance of this valve



Installation



Operation

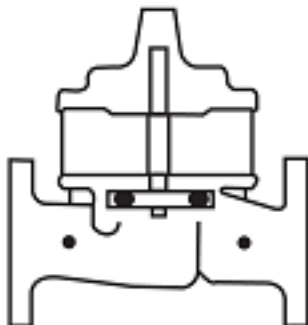

Maintenance





Recommended Inspections

Cla-Val recommends that an inspection be performed on our products annually. The inspection should include both a visual and functional test of the main valve/component and the pilot system. The inspection ensures that no damage or premature wear occurred due to velocity, pressure, or foreign matter within the fluid that may have exceeded the valve's design. Please consult the maintenance manual for specific information on the model. Manuals are available for download at Cla-Val.com, as well as contact information for a company representative.

Accurate record-keeping is a best practice for any preventative maintenance program, and Cla-Val strongly recommends this action through an asset management program. Cla-Val provides a free asset management tool, Link2Valves [Link2Valves - Cla-Val \(cla-val.com\)](http://Link2Valves - Cla-Val (cla-val.com)), to assist in preventative maintenance record-keeping and scheduling.



— MODEL — **100-03**

Powercheck Valve

DESCRIPTION

This manual contains information for installation, operation and maintenance of the Cla-Val 100-03 Powercheck, an automatic valve designed for use where independent operating pressure is desired, or when line fluid is unsuitable as an operating medium.

This valve is a hydraulically operated, diaphragm type, globe or angle pattern valve. It is single seated and incorporates into its design two operating chambers sealed from one another by a flexible synthetic rubber diaphragm. Pressure applied to the upper chamber closes the valve; when applied to the lower chamber, it opens the valve.

With proper pilot controls, the valve can be held in any intermediate position between fully open and tightly closed unless a static condition or pressure reversal occurs, in which case the valve closes to prevent return flow regardless of the diaphragm position.

INSTALLATION

Allow sufficient room around the valve assembly to make adjustments and for disassembly.

NOTE: BEFORE THE VALVE IS INSTALLED, PIPE LINES SHOULD BE FLUSHED OF ALL CHIPS, SCALE AND FOREIGN MATTER.

It is recommended that gate or block valves be installed on both the upstream and downstream sides of the 100-03 to facilitate isolating the valve for preventative maintenance.

Place the valve in the line with flow through the valve in the direction indicated on the inlet name plate or by flow arrows and with the cover "UP". Other positions are not acceptable due to the check feature.

When a pilot control system is installed on the Powercheck Valve, use care to prevent damage. If it is necessary to remove fittings or components, be sure they are kept clean and replaced in the exact order of removal.

After the valve is installed and the system is first pressurized, vent air from the cover chamber and tubing by loosening fittings at all high points.

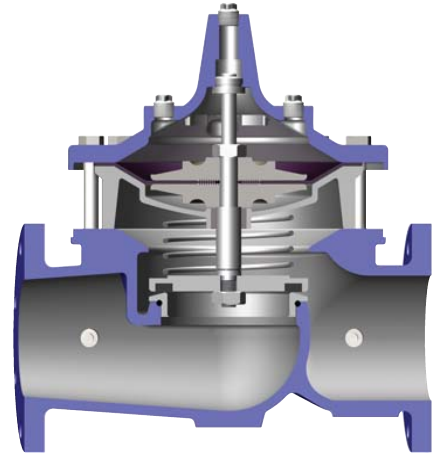

TROUBLE SHOOTING

The following trouble shooting information deals strictly with the Powercheck Valve; however some "possible causes" will refer to components that may exist in the variety of control systems available for the valve. All trouble shooting is possible without removing the valve from the line.

SERVICE SUGGESTIONS

(Service Suggestions Chart)

CAUTION: Extreme care should be taken when servicing the valve. Gate or line block valves must be closed upstream and downstream of the valve before starting disassembly. When there are no block or gate valves to isolate the Powercheck Valve it should be realized that the valve cannot be serviced under pressure. Steps must be taken to remedy this situation before proceeding.

Principle of Operation

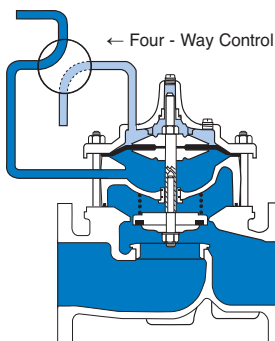

Full Open Operation

When operating pressure below the diaphragm is applied and pressure is relieved from the cover chamber, the valve is held open allowing full flow.

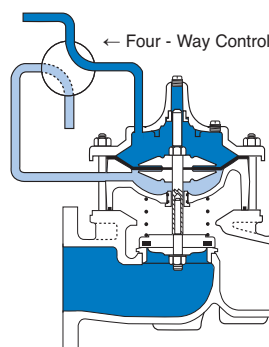

Tight Closing Operation

When pressure below the diaphragm is relieved and operating pressure is applied to the cover chamber, the valve closes drip-tight.

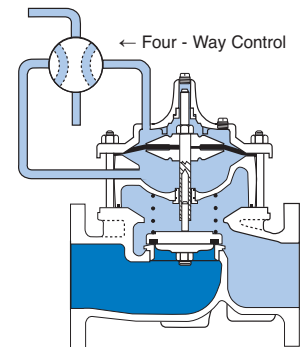

Check Action

When a static condition or pressure reversal occurs, the split stem design allows the valve to instantly check closed. Return flow is prevented regardless of the diaphragm's position.

Note: For optimum operation of built-in check feature, installation with stem vertically up is recommended.

MAINTENANCE

Preventative Maintenance

The Cla Val Powercheck Valves require no lubrication or packing and a minimum of maintenance. However, a periodic inspection schedule should be established to determine how the fluid velocity as well as the substances occurring in natural waters are effecting the valve. These substances can be dissolved minerals, colloidal and suspended particles. Effect of these actions or substances must be determined by inspection.

DISASSEMBLY

First mark the side of the valve cover, power unit body and valve body so that reassembly of these parts will be exact) as removed.

The Powercheck Valve inspection or maintenance can be accomplished without removal of the valve body from the line. Shut off pressure to the valve, both inlet, outlet and independent operating pressure when used.

WARNING: Maintenance personnel can be injured and equipment and property damaged if disassembly is attempted with pressure in the system.

After pressure has been released from the valve control system and operating chambers of the valve, remove the controls and tubing. Obtain a schematic of the assembly or note and sketch position of tubing and controls for reassembly. Replacing tubing into the control ports exactly as removed is necessary. Failure to reassemble properly will cause the valve to malfunction and possibly cause serious damage.

Remove cover nuts and cover. If the valve has been in service for any length of time' chances are the cover will have to be loosened by driving upward along the edge of the cover with a dull cold chisel. See Figure 1.

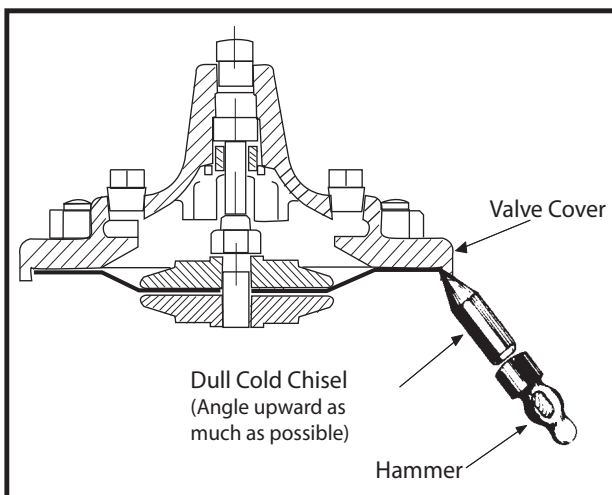

FIGURE 1.

NOTE:

When block and tackle or a power hoist is to be used to lift the valve cover insert a proper size eye bolt in place of the center cover plug. Pull cover straight up to keep from damaging the power unit stem bearing and upper stem.

Power unit body can now be lifted from the valve body. The stem with diaphragm will be removed with the power unit body. The disc retainer assembly with lower stem will separate (check feature) from the upper stem and power unit body.

CAUTION: During service performed on the stem assembly, the stem surfaces must not be damaged. If a vice or other holding device is used to grip the stem, soft jaws of brass or copper must be used to protect the precision ground surface of the stainless steel stem. If the stem is marred no amount of careful dressing can restore the stem to its original condition.

Inspect the threads on the stem. Mineral deposits that prevent the nuts from turning must be cleaned from the threads.

A 5% solution of muriatic acid will soften mineral or scale deposits to assist in removal of nuts and the general cleaning of parts. Flush the parts thoroughly with water immediately after cleaning. Care must always be exercised when handling acid. Read the warning label on the acid container to be sure of correct method of use and disposal after use.

Hold the stem in a vice with soft jaws (see above) when removing the stem nut. Slide off the assembly leaving a completely disassembled upper stem assembly. Remove the disc and disc retainer from the lower stem. Refer to the sectional view of the valve size being serviced. This will assist in the disassembly procedure outlined above. Reassembly instructions outline proper procedure and quantity of spacer washers. This is especially important if the disc is replaced.

Check the upper and lower stems for scale and freedom of movement. Insert the lower stem into the stem (upper). The insertion fully of these parts must be free from binding or resistance. Clean and polish the telescoping parts. Restricted movement of these parts could cause the check feature to fail to function.

Inspection Of Parts

Returning to the valve body in the line, the seat should now be inspected for damage. If the seat requires removal use the following tools. Seats in valve sizes 1/2" and 3/4" can be removed with a hex socket wrench. Seats in valve sizes 1" through 6" should be removed with accessory X-109 Seat Removing Tool available from the factory. Seats in valve sizes 8" through 16" may be removed with a screw driver. If upon removal of the screws the seat cannot be lifted out, it will be necessary to use a hard rubber mallet and tap the seat loose.

Any buildup of mineral or scale should be cleaned from the valve body at this time. Inspection of the cover and power unit body surfaces that contact the diaphragm is important. Clean and smooth, with wet or dry emery paper, any roughness that could damage the diaphragm. Inspect and recondition the surface on the upper and lower diaphragm washers. The perimeter of the diaphragm washers is the most likely area to cause diaphragm wear if the surface is not smooth. Take extra care to make this a smooth finish.

Inspect the power unit body bearing insert O-ring that is in contact with the stem. If it is worn, nicked or cut, replace it.

The cover bearing should also be checked for excessive wear, using the upper end of the stem to check for excessive lateral movement. A special tool for each size valve is available from the factory to remove the cover bearing. Cover bearing replacement is seldom necessary.

Inspect the diaphragm for cracks or chafing. Replace the diaphragm if damaged.

Inspect the disc and replace if the surface is damaged or worn. If a new disc is not available, the existing disc can be turned over, exposing the unused surface for contact with the seat.

The disc guide should be checked and cleaned of scales and mineral deposits. Due to the close tolerance between the outer periphery of the disc guide and the inner area of the valve seat, no scale or mineral deposits should be overlooked.

REASSEMBLY

To reassemble, reverse the order of disassembly

If the disc has been removed, it is important that correct pressure be on the disc from the disc guide when the lower stem nut is tight. Use sufficient spacer washers to obtain slight pressure (by visual indentation) on the disc. Indention should be slight. Refer to seat and disc detail drawings for location of spacer washers for various valve sizes.

NOTE: New discs will usually require a different number of spacer washers to obtain the right amount of "grip" on the disc.

Place the lower stem assembly onto the seat with the disc in contact with the valve seat. If a large spring (4", 6", 8" only) was removed upon disassembly, replace on top of the disc retainer.

The power unit body with gasket, (body to power unit) or O-ring, can be installed on the body. Be sure the power unit section is replaced exactly in the same position as removed. The end of the lower stem will be visible in the center of the power unit bearing. Care must be taken so the power unit bearing or lower stem is not damaged during this assembly. A hoist may be necessary for large valve sizes.

NOTE: Valves 4" thru 16" use an O-ring body to power unit seal. During placement onto the body apply a light weight grease into the power unit groove to hold the O-ring in place when installing on the body.

Install on the upper stem the lower diaphragm washer, the diaphragm, the upper diaphragm washer, then screw the stem nut and tighten securely so the upper and lower diaphragm washer cannot be turned on the stem. During the tightening of the upper stem nut, the stem should be held in a vice with soft brass jaws. The upper stem and diaphragm assembly can now be lowered into the power unit bearing, the hollow end of the stem sliding on to the end of the lower stem. Move the upper stem and diaphragm assembly up and down to check freedom of movement of the lower and upper stem.

CAUTION: Do not lubricate or grease the hollow end of upper stem or upper end of the lower stem. This could cause the check feature to become inoperative.

Replace cover chamber spring on the upper diaphragm washer.

NOTE: Some valves may not have a cover chamber spring.

Place the cover on the power unit body aligning the index marks. Secure the cover with 8 stud nuts Tighten the nuts firmly with a cross-over pattern until all nuts are tight:

NOTE: Valve sizes 1" thru 3" are bolted with 8 nuts (power unit body to valve body) and 8 nuts (cover to power unit body). Tighten stud nuts firmly with cross-over pattern until all nuts are tight.

When the stem is removed from the valve a tool can be fabricated to check for unrestricted stem movement after reassembly, and also check for correct stem travel. Valves size 1 1/4" thru 24/2" are threaded 10-32 UNF (internal threads) on the top of the stem. Valve sizes 3" and 4" are threaded , 1/4 -28 UNF. Valve sizes 6" thru 14" are threaded 3/4-24 UNF. The 16" valves are threaded, 1/2-20 UNF.

A length of rod threaded on one end can be threaded into the stem through the plug hole in the center of the cover. It is possible with this rod to move the diaphragm assembly up from the seat freely, returning to the seat by its own weight. Larger valve sizes may require a tee handle to assist lifting heavier assemblies. The stroke of the stem should correspond closely with the chart.

Reinstall the control system and tubing exactly as it was before disassembly.

The Powercheck Valve can be tested for tight closure as well as the tightness of the seal across the diaphragm. inlet line pressure, or independent operating pressure can also be used to check the freeness and travel of the diaphragm assembly. Refer to the operation paragraph and principle of operation sectional views for opening and closing operation.

The downstream or outlet shutoff valve remains closed.

If the control system has a pilot or control that can position the valve to a closed position, put the control in a position to close the Powercheck. Lacking a control, inlet pressure must be connected to the cover of the Powercheck Valve.

Open upstream gate or line block valve just enough to allow flow.

Have the power unit body, center section, open to atmosphere. The power unit body will be atmospheric if the control is being used.

Partially disconnect a fitting on the discharge side of the valve. Do not remove fully unless there is no pressure.

After the valve is in the closed position for a few minutes, all draining of the power unit body should stop. This will indicate a good seal across the valve seat and the diaphragm.

USEFUL INFORMATION OR HINTS

1.The approximate volume of liquid discharged from the chamber above the diaphragm when the valve moves from the fully closed position to fully open is as follows:

VALVE SIZE	DISPLACEMENT	
1/2"	0.340 Fl. Oz.	.01 Liters
3/4"	0.340 Fl. Oz.	.01 Liters
1"	0.700 Fl. Oz.	.02 Liters
1 1/4"	0.020 Gal.	.10 Liters
1 1/2"	0.020 Gal.	.10 Liters
2"	0.032 Gal.	.10 Liters
2 1/2"	0.043 Gal.	.20 Liters
3"	0.080 Gal.	.30 Liters
4"	0.169 Gal	.60 Liters
6"	0.531 Gal.	2.00 Liters
8"	1.260 Gal.	4.75 Liters
10"	2.510 Gal.	9.50 Liters
12"	4.000 Gal.	15.14 Liters
14"	6.500 Gal.	24.60 Liters
16"	9.570 Gal.	36.20 Liters

SERVICE SUGGESTIONS

SYMPTOM	POSSIBLE CAUSE	TEST PROCEDURE	REMEDY
Valve fails to close.	Stem stuck in open position.	Vent power unit chamber. Apply pressure to cover chamber. Valve should close.	Disassemble, examine all internal parts for cause of the sticking condition and clean off scale deposits.
	Worn diaphragm or loose upper stem nut.	Apply pressure in power unit chamber and vent cover. Continuous flow from cover indicates this trouble.	Disassemble and replace diaphragm or tighten the valve stem nut.
	Foreign object on valve seat.	Valve opens okay, but only closes part way.	Try operating valve a few times. This might dislodge the object. If this fails, disassemble and remove the obstruction.
	Pressure not being released from power unit chamber.	Make sure pressure is being released by opening a fitting into the chamber. It valve then closes, refer to remedy.	Check control system. Tube line or nipple might be plugged up.
	Operating pressure not getting into valve cover.	Use pressure gauge or loosen cover plug to check for pressure.	Clean tubing or pipe fittings into cover chamber. Open CK2 Isolation Valve in control lines.
Insufficient line pressure.	Check line pressure.	Establish line pressure.	
Valve fails to open.	Stem stuck in Closed or semiopen position.	Vent cover. Apply pressure to power unit chamber.	Disassemble, examine all internal parts for cause of the sticking problem, and clean off scale deposits.
	Worn diaphragm or loose upper stem nut.	Apply pressure in power unit chamber and vent cover. Continuous flow from cover indicates this problem.	Disassemble and replace diaphragm or tighten valve stem nut.
	Foreign object on top of disc retainer.	Valve closed okay but won't open all the way.	Try operating valve a few times. This might dislodge the object. If this fails, disassemble and remove the obstruction.
	Pressure not being released from cover chamber.	Open a fitting or remove a plug from cover chamber. It cover chamber vents and valve opens, see remedy.	Check control system. Check lines or pipe fittings. Clean out any plugged lines.
	Operating pressure not applied into power unit chamber.	Loosen a fitting in this chamber to check for pressure at this point.	Clean tubing or pipe fittings into power unit chamber.
Valve closes but leakage occurs.	Worn disc or seat.	The best procedure here is to disassemble the valve and inspect these parts.	Replace worn parts.
O-Ring failure.	Mineral deposits on stem cause abrasion on O-ring.	Remove pressure from both cover and power unit chambers and apply line pressure to valve. Open line from power unit chamber and observe continuous flow.	Disassemble and replace O-ring.

FREEDOM OF MOVEMENT

The following procedures can be used to determine if the valve opens and closes fully. During this test the diaphragm can be checked for damage.

The Powercheck Valve will have a control to open and close the valve. Position the control so that pressure is applied to the cover chamber (above the valve diaphragm). This will close the Powercheck Valve. Check the drain from the control that discharges to atmosphere.

Once the liquid from the lower diaphragm chamber is drained the discharge should stop. If the discharge continues after the normal time it takes to drain then the diaphragm is damaged, or the stem nut is loose, or the stem o-ring is leaking. If the discharge is continuous from both chambers then there is a possibility that the diaphragm or the pilot control is damaged.

If the valve is equipped with a "Dry Drain" (control drain piped to downstream end of the valve) then same procedure is followed except the CK2 Shutoff Cock on the downstream end of the valve must be closed and the drain line disconnected and drained to atmosphere. It can then be checked as above.

Measurement of the vertical travel of the stem (diaphragm assembly) will make it possible to determine if the travel, or stroke is restricted. The following chart provides this measurement. It is necessary to have either the X101 Valve Position Indicator or X105 Limit Switch Assembly installed on the valve to visually check the travel.

Mark the position of the stem on the X101 or X105 when the valve is closed. Reposition the control so that pressure is applied below the diaphragm and the cover chamber is drained. Determine the extent of the stem travel. Check this movement with the stem travel chart. If the stroke is different than listed (5% to 10%) then there is good reason to believe something is mechanically restricting the stroke of the valve at one end of its travel. If it is determined that flow does not stop through the valve when in the indicated "closed" position, the obstruction probably is between the disc and the seat, or in the power unit chamber below the diaphragm. If the flow stops, the obstruction is likely in the cover chamber above the diaphragm or possibly above the disc retainer. Refer to the sectional view under Principle of Operation.

If operation of the valve a few times does not dislodge the foreign object obstructing the diaphragm assembly (stem) movement then the valve must be disassembled and the problem located and corrected. See disassembly instructions.

STEM TRAVEL

(fully open to fully closed)

VALVE SIZE		TRAVEL	
INCHES	MM	INCHES	MM
1	25	0.3	8
1 1/4	32	0.4	10
1 1/2	40	0.4	10
2	50	0.6	15
2 1/2	65	0.7	18
3	80	0.8	20
4	100	1.1	23
6	150	1.7	43
8	200	2.3	58
10	250	2.8	71
12	300	3.4	86
14	350	3.9	99
16	400	4.5	114

100-03 Powercheck Valve 1" - 3" Sizes

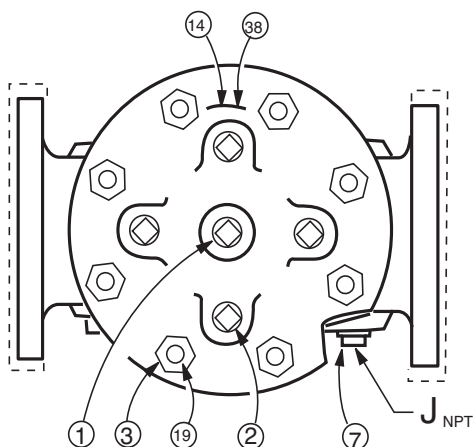
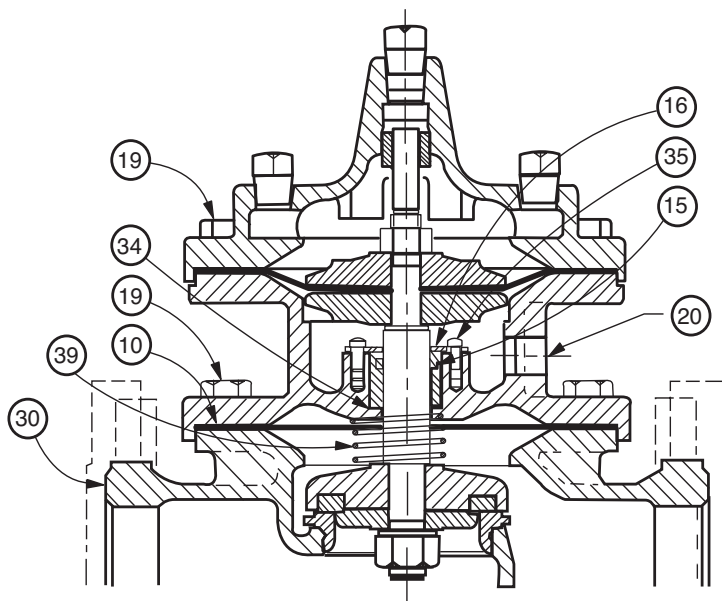

Cover View

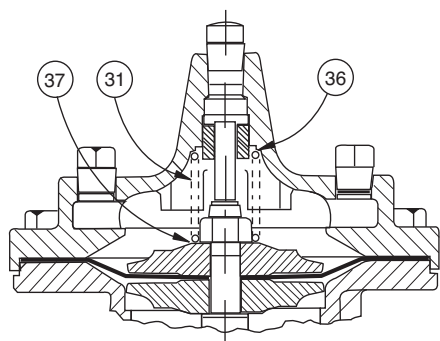

Model 100-03KH

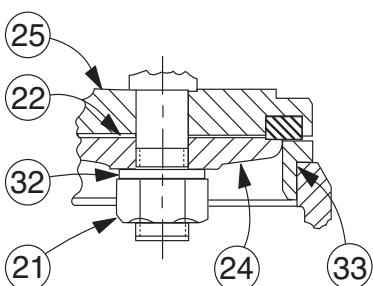

1" - 3"
Seat & Disc Details

ITEM NO.	PART DESCRIPTION	Qty
1	Center Cover Plug	1
2	Cover Plug	A/R
3	Hex Nut (4"-16" only)	A/R
4	Cover Bearing	1
5	Cover	1
6	Pipe Cap (16" only)	1
7	Body Plug	A/R
8	Hex Bolt (16" only)	8
9*	O-Ring (16" only)	1
10*	Gasket (1" - 3" only)	1
11	Upper Stem Nut	1
12	Diaphragm Washer	2
13*	Diaphragm	1
14	Nameplate	1
15*	Stem O-Ring	1
16	Bearing Retainer (1" -3" only)	1
16	Bearing Ring Retainer (4" - 16" only)	1
17	Powerunit Body	1
18*	Bearing O-Ring (4" - 16" only)	1
19	Hex Bolt (1" - 3" only)	A/R
19	Stud (4" - 16" only)	A/R
20	Powerunit Body	1
21	Lower Stem Nut	1
22	Spacer Washer	A/R
23	Screw, Flat Hd (6" - 16" Only)	A/R
24	Disc Guide	1
25	Disc Retainer	1
26*	Disc	1
27	Upper Stem	1
28	Screw, Flat Hd (8" - 16" only)	A/R
29	Seat	1
30	Body	1
31	Spring (100PCKH / 100CAKH only)	1
32	Lockwasher	1
33*	Seat O-Ring	1
34*	Gasket, Bearing (1" - 3" only)	1
35	Screw FIL. Hd (1"-2 1/2" Bolt HX Hd (3"))	4
36	Upper Spring Washer (100PCKCH / 100PCKCH)	1
37	Lower Spring Washer (100PCKCH / 100PCKCH)	1
38	Drive Screw	2
39	Lower Spring (1" - 10" only)	1
40	Lower Stem	1
41	Cover Bearing Housing (16" only)	1
*Recommended Spare Parts		

100-03 Powercheck Valve 4" - 16" Sizes

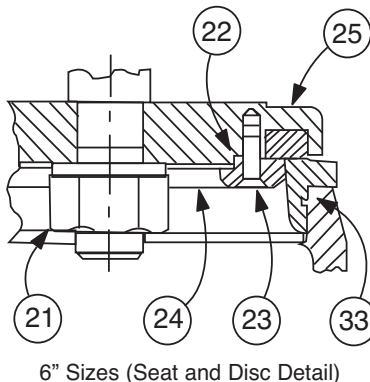
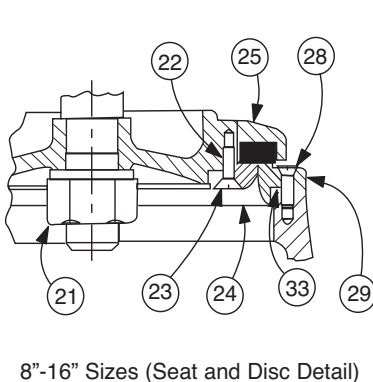
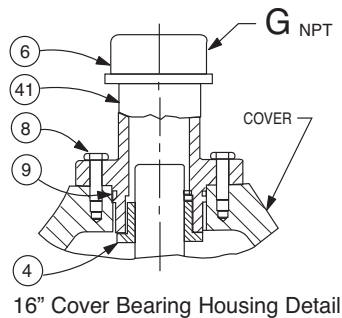
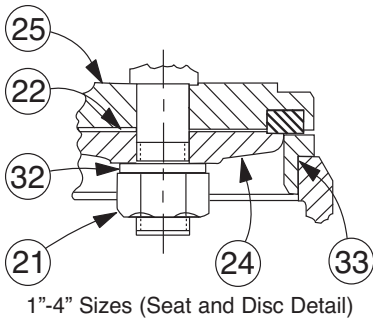
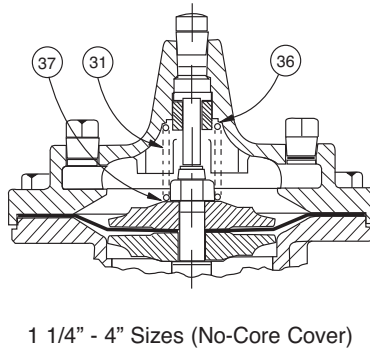
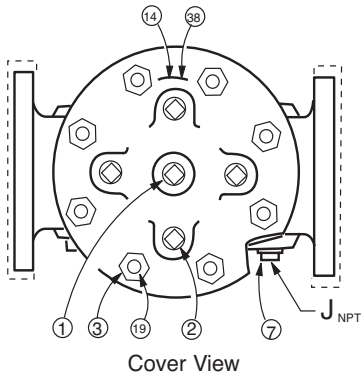
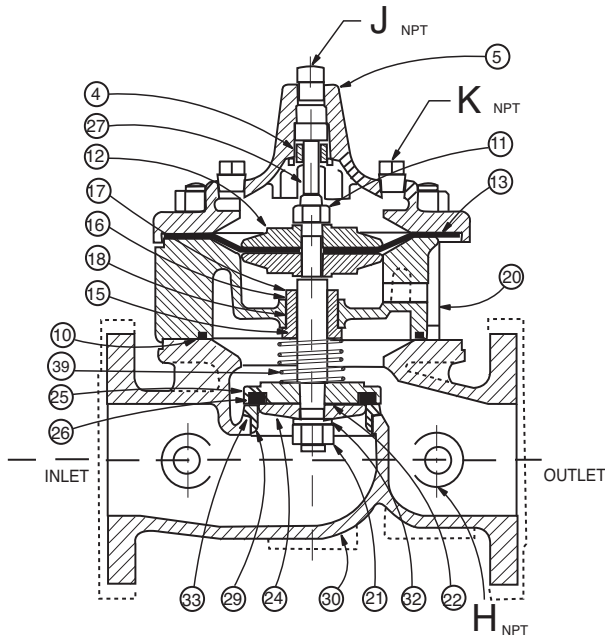

ITEM NO.	PART DESCRIPTION	Qty
1	Center Cover Plug	1
2	Cover Plug	A/R
3	Hex Nut (4" - 16" only)	A/R
4	Cover Bearing	1
5	Cover	1
6	Pipe Cap (16" only)	1
7	Body Plug	A/R
8	Hex Bolt (16" only)	8
9*	O-Ring (16" only)	1
10*	Gasket (1" - 3" only)	1
11	Upper Stem Nut	1
12	Diaphragm Washer	2
13*	Diaphragm	1
14	Nameplate	1
15*	Stem O-Ring	1
16	Bearing Retainer (1" - 3" only)	1
	Bearing Ring Retainer (4" - 16" only)	1
17	Powerunit Body	1
18*	Bearing O-Ring (4" - 16" only)	1
19	Hex Bolt (1" - 3" only)	A/R
	Stud (4" - 16" only)	A/R
20	Powerunit Body	1
21	Lower Stem Nut	1
22	Spacer Washer	A/R
23	Screw, Flat Hd (6" - 16" Only)	A/R
24	Disc Guide	1
25	Disc Retainer	1
26*	Disc	1
27	Upper Stem	1
28	Screw, Flat Hd (8" - 16" only)	A/R
29	Seat	1
30	Body	1
31	Spring (100PCKH / 100CAKH only)	1
32	Lockwasher	1
33*	Seat O-Ring	1
34*	Gasket, Bearing (1" - 3" only)	1
35	Screw FIL. Hd (1"-2 1/2" Bolt HX Hd (3"))	4
36	Upper Spring Washer (100PCKCH / 100CAKCH)	1
37	Lower Spring Washer (100PCKCH / 100CAKCH)	1
38	Drive Screw	2
39	Lower Spring (1" - 10" only)	1
40	Lower Stem	1
41	Cover Bearing Housing (16" only)	1
*Recommended Spare Parts		

Functional Data

Model 100-03

Valve Size		Inches	2½	3	4	6	8	10	12	14	16
		mm.	65	80	100	150	200	250	300	350	400
C_V Factor	Globe Pattern	Gal./Min. (gpm.)	85	115	200	440	770	1245	1725	2300	2940
		Litres/Sec. (l/s.)	20	28	48	106	185	299	414	552	706
	Angle Pattern	Gal./Min. (gpm.)	101	139	240	541	990	1575	2500*	3060*	4200*
		Litres/Sec. (l/s.)	24	33	58	130	238	378	600	734	1008
Equivalent Length of Pipe	Globe Pattern	Feet (ft.)	53	85	116	211	291	347	467	422	503
		Meters (m.)	16	26	35	64	89	106	142	129	154
	Angle Pattern	Feet (ft.)	37	58	80	139	176	217	222*	238*	247*
		Meters (m.)	12	18	25	43	54	66	68	73	75
K Factor	Globe Pattern	4.6	6.0	5.9	6.2	6.1	5.8	6.1	5.0	5.2	
	Angle Pattern	3.3	4.1	4.1	4.1	3.7	3.6	2.9	2.8	2.6	
Liquid Displaced from Cover Chamber When Valve Opens		Fl. Oz	—	—	—	—	—	—	—	—	—
		U.S. Gal.	.04	.08	.17	.53	1.26	2.51	4.0	6.5	9.6
		ml	163	303	643	—	—	—	—	—	—
		Litres	—	—	—	2.0	4.8	9.5	15.1	24.6	36.2

*Estimated

C_V Factor

Formulas for computing C_V Factor, Flow (Q) and Pressure Drop (ΔP):

$$C_V = \frac{Q}{\sqrt{\Delta P}} \quad Q = C_V \sqrt{\Delta P} \quad \Delta P = \left(\frac{Q}{C_V} \right)^2$$

K Factor (Resistance Coefficient)

The Value of K is calculated from the formula: $K = \frac{894d^4}{C_V^2}$
(U.S. system units)

Equivalent Length of Pipe

Equivalent lengths of pipe (L) are determined from the formula: $L = \frac{Kd}{12f}$
(U.S. system units)

Fluid Velocity

Fluid velocity can be calculated from the following formula: $V = \frac{.4085 Q}{d^2}$
(U.S. system units)

Where:

C_V = U.S. (gpm) @ 1 psi differential at 60° F water
or
= (l/s) @ 1 bar (14.5 PSIG) differential
at 15° C water

d = inside pipe diameter of Schedule 40 Steel Pipe (inches)

f = friction factor for clean, new Schedule 40 pipe
(dimensionless) (from Cameron Hydraulic Data,
18th Edition, P 3-119)

K = Resistance Coefficient (calculated)

L = Equivalent Length of Pipe (feet)

Q = Flow Rate in U.S. (gpm) or (l/s)

V = Fluid Velocity (feet per second) or (meters per second)

ΔP = Pressure Drop in (psi) or (bar)

Model 100-03 Flow Chart (Based on normal flow through a wide open valve)

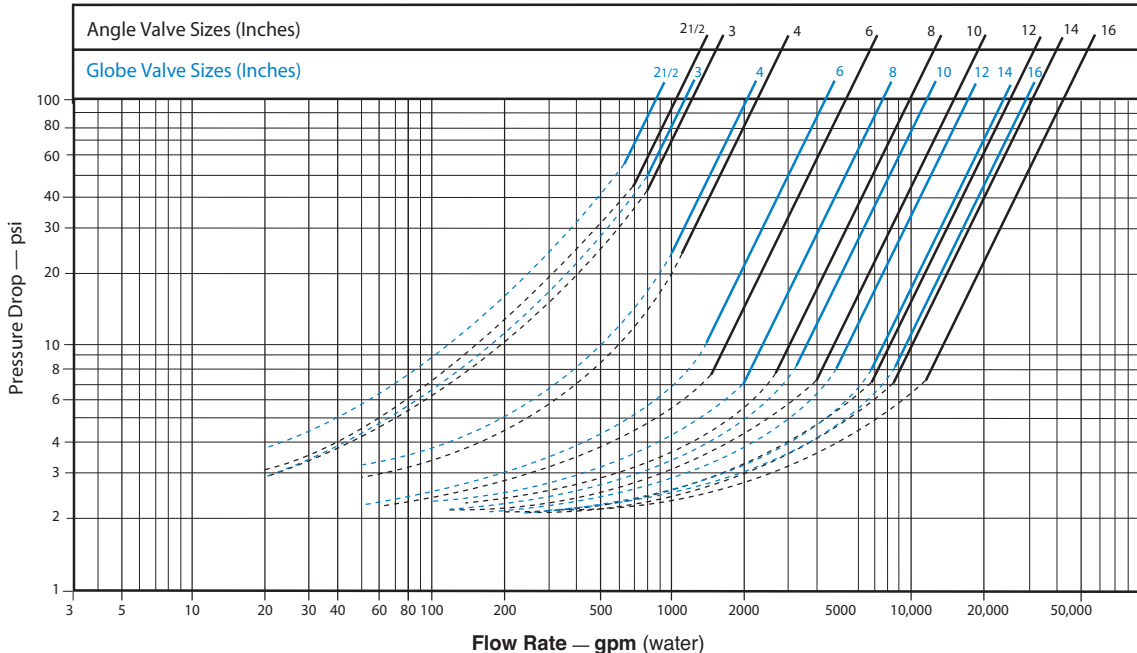

Dimensions

100-03 (Globe)

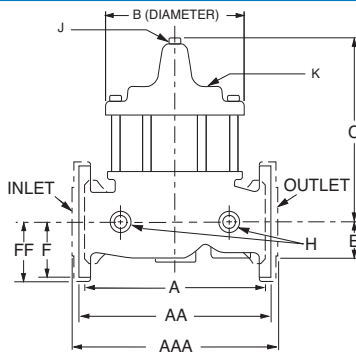

Model 100-03

100-03 (Angle)

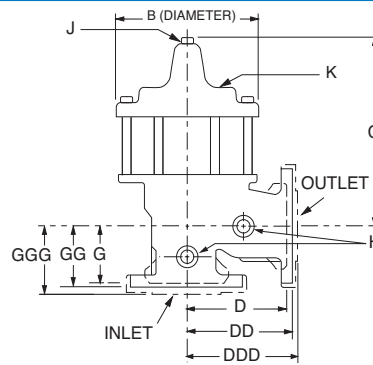

Valve Size (Inches)	2 ½	3	4	6	8	10	12	14	16
A Threaded	11.00	12.50	—	—	—	—	—	—	—
AA 150 ANSI	11.00	12.00	15.00	20.00	25.38	29.75	34.00	39.00	41.38
AAA 300 ANSI	11.62	13.25	15.62	21.00	26.38	31.12	35.50	40.50	43.50
B Dia.	8.00	9.12	11.50	15.75	20.00	23.62	28.00	32.75	35.50
C Max.	10.31	11.19	14.25	18.44	21.81	23.38	29.31	32.12	35.00
D Threaded	5.50	6.25	—	—	—	—	—	—	—
DD 150 ANSI	5.50	6.00	7.50	10.00	12.69	14.88	17.00	19.50	20.69
DDD 300 ANSI	5.81	6.63	7.81	10.50	13.19	15.56	17.75	20.25	21.75
E	1.69	2.06	3.19	4.31	5.31	9.25	10.75	12.62	15.50
F 150 ANSI	3.50	3.75	4.50	5.50	6.75	8.00	9.50	10.50	11.75
FF 300 ANSI	3.75	4.13	5.00	6.25	7.50	8.75	10.25	11.50	12.75
G Threaded	4.00	4.50	—	—	—	—	—	—	—
GG 150 ANSI	4.00	4.00	5.00	6.00	8.00	8.62	13.75	14.88	15.69
GGG 300 ANSI	4.31	4.38	5.31	6.50	8.50	9.31	14.50	15.62	16.50
H NPT Body Tapping	½	½	¾	¾	1	1	1	1	1
J NPT Cover Center Plug	½	½	¾	¾	1	1	1¼	1½	2
K NPT Cover Tapping	½	½	¾	¾	1	1	1	1	1
Valve Stem Internal Thread UNF	10-32	¼-28	¼-28	¾-24	¾-24	¾-24	¾-24	¾-24	½-20
Stem Travel	0.7	0.8	1.1	1.7	2.3	2.8	3.4	4.0	4.5
Approx. Ship Wt. Lbs.	65	95	190	320	650	940	1675	2460	3100

Valve Size (mm)	65	80	100	150	200	250	300	350	400
A Threaded	279	318	—	—	—	—	—	—	—
AA 150 ANSI	279	305	381	508	645	756	864	991	1051
AAA 300 ANSI	295	337	397	533	670	790	902	1029	1105
B Dia.	203	232	292	400	508	600	711	832	902
C Max.	262	284	362	468	554	594	744	816	889
D Threaded	140	159	—	—	—	—	—	—	—
DD 150 ANSI	140	152	191	254	322	378	432	495	526
DDD 300 ANSI	148	168	198	267	335	395	451	514	552
E	43	52	81	109	135	235	273	321	394
F 150 ANSI	89	95	114	140	171	203	241	267	298
FF 300 ANSI	95	105	127	159	191	222	260	292	324
G Threaded	102	114	—	—	—	—	—	—	—
GG 150 ANSI	102	102	127	152	203	219	349	378	399
GGG 300 ANSI	110	111	135	165	216	236	368	397	419
H NPT Body Tapping	½	½	¾	¾	1	1	1	1	1
J NPT Cover Center Plug	½	½	¾	¾	1	1	1¼	1½	2
K NPT Cover Tapping	½	½	¾	¾	1	1	1	1	1
Valve Stem Internal Thread UNF	10-32	¼-28	¼-28	¾-24	¾-24	¾-24	¾-24	¾-24	½-20
Stem Travel	18	20	28	43	58	71	86	102	114
Approx. Ship Wt. Kgs.	30	43	86	145	295	426	760	1116	1406

Cla-Val Control Valves operate with maximum efficiency when mounted in horizontal piping with the main valve cover UP, however, other positions are acceptable. Due to component size and weight of 8 inch and larger valves, installation with cover UP is advisable. We recommend isolation valves be installed on inlet and outlet for maintenance. Adequate space above and around the valve for service personnel should be considered essential. A regular maintenance program should be established based on the specific application data. However, we recommend a thorough inspection be done at least once a year. Consult factory for specific recommendations.



Model CV FLOW CONTROL

DESCRIPTION

The CV Control is an adjustable restriction which acts as a needle valve when flow is in the direction of the stem. When flow is in the reverse direction, the port area opens fully to allow unrestricted flow. When installed in the control system of a Cla-Val automatic valve, it can be arranged to function as either an opening or closing speed control.

OPERATION

The CV Flow Control permits full flow from port A to B, and restricted flow in the reverse direction. Flow from port A to B lifts the disc from seat, permitting full flow. Flow in the reverse direction seats the disc, causing fluid to pass through the clearance between the stem and the disc. This clearance can be increased, thereby increasing the restricted flow, by screwing the stem out, or counter-clockwise. Turning the stem in, or clockwise reduces the clearance between the stem and the disc, thereby reducing the restricted flow.

INSTALLATION

Install the CV Flow Control as shown in the valve schematic. All connections must be tight to prevent leakage.

DISASSEMBLY

Follow the sequence of the item numbers assigned to the parts in the cross sectional illustration for recommended order of disassembly.

Use a scribe, or similar sharp-pointed tool to remove O-ring from the stem.

INSPECTION

Inspect all threads for damage or evidence of cross-threading. Check mating surface of seat and valve disc for excessive scoring or embedded foreign particles. Check spring for visible distortion, cracks and breaks. Inspect all parts for damage, corrosion and cleanliness.

CLEANING

After disassembly and inspection, cleaning of the parts can begin. Water service usually will produce mineral or lime deposits on metal parts in contact with water. These deposits can be cleaned by dipping the parts in a 5-percent muriatic acid solution just long enough for deposits to dissolve. This will remove most of the common types of deposits. **CAUTION: Use extreme care when handling acid.** If the deposit is not removed by acid, then a fine grit (400) wet or dry sandpaper can be used with water. Rinse parts in water before handling. An appropriate solvent can clean parts used in fueling service. Dry with compressed air or a clean, lint-free cloth. Protect from damage and dust until reassembled.

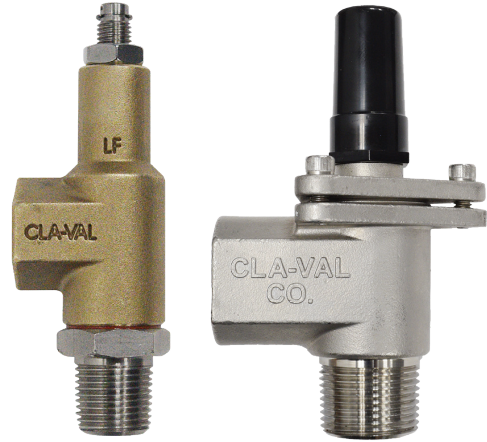

REPAIR AND REPLACEMENT

Minor nicks and scratches may be polished out using a fine grade of emery or crocus cloth; replace parts if scratches cannot be removed.

Replace O-ring packing and gasket each time CV Flow Control is overhauled.

Replace all parts which are defective. Replace any parts which create the slightest doubt that they will not afford completely satisfactory operation. Use Inspection steps as a guide.

REASSEMBLY

Reassembly is the reverse of disassembly; no special tools are required.

TEST PROCEDURE

No testing of the flow Control is required prior to reassembly to the pilot control system on Cla-Val Main Valve.





3/8" CV Flow Control

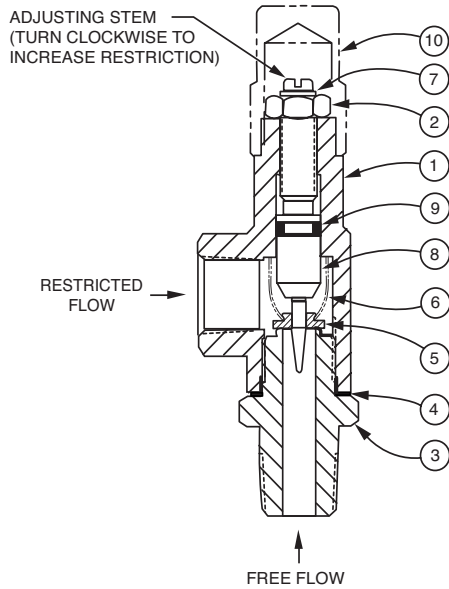

Item No.	Description	QTY
1	Housing	1
2	Nut, Jam	1
3	Seat	1
4	Gasket	1
5	Disc	1
6	Spring	1
7	Ring, Retaining	1
8	Stem	1
9	O-Ring	1
10	Cap (SS only)	1

1/2", 3/4", and 1" CV Flow Control

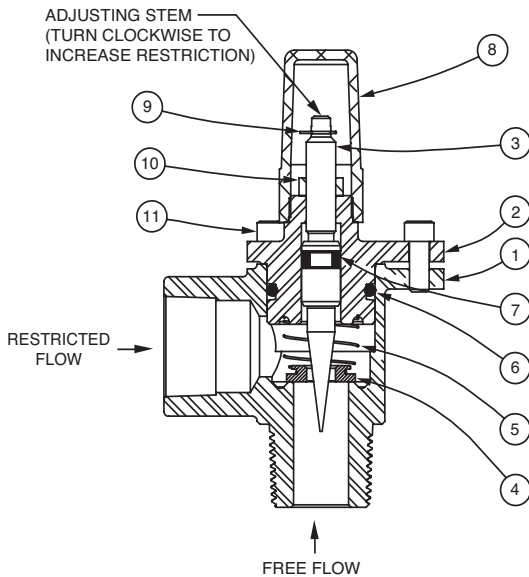

Item No.	Description	QTY
1	Body	1
2	Cover	1
3	Stem	1
4	Disc	1
5	Spring	1
6	O-Ring	1
7	O-Ring	1
8	Cap	1
9	Ring, Retaining	1
10	Nut, Jam	1
11	Socket Head Cap Screw	3

When Ordering, Please Specify

1. All Nameplate/Stamped data
2. Item Number
3. Description
4. Material





CSM-11

Solenoid Control

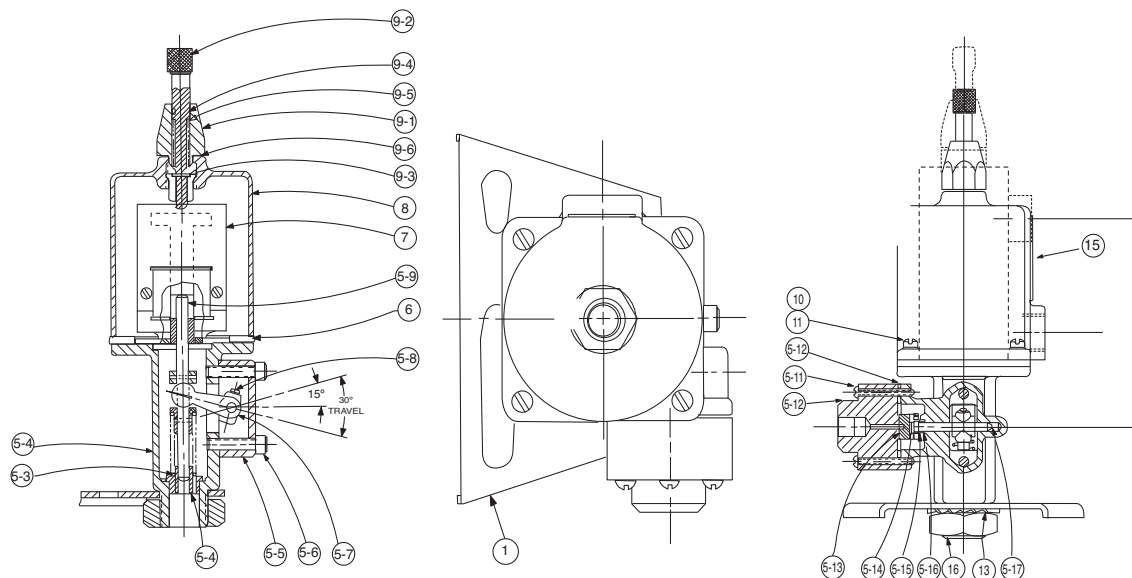

Item	Description	Item	Description
1	Mounting Bracket	7	Solenoid Assy. (See table other side)
5	Mechanical Parts Assy.	8	Cover
5-2	Housing	9	Manual Operator Assy.
5-3	Spring	9-1	Housing, Manual Operator
5-4	Guide	9-2	Plunger
5-5	Side Housing	9-3	Pin, groove-3/8"
5-6	Cap Screw 1/4"	9-4	"O"- Ring
5-7	Lever Arm	9-5	Spring, Manual Operator
5-8	Lever Screw	9-6	Gasket, Manual Operator
5-9	Stem Assy. (Solenoid)	10	Machine Screw Fil. Hd. 10/32 x 5/8 (4 reqd)
5-10	Distributor Gasket		Lockwasher
5-11	Machine Screw, RDH (6/32 x 1 1/4 - 6 reqd.)	11	Machine Screw Fil. Hd.
5-12	Distributor (CSM11-A2-2)	12	
5-13	Disc Assy.		Lockwasher
5-14	Spring (Disc Assy.)	13	Lockwasher
5-15	Thrust Washer	14	Coil only: (See table other side)
5-16	"O"- Ring	15	Nameplate
5-17	Stem Assy. (Pilot)	16	Hex Nut, Jam 1-14 UNS
6	Spacer Gasket		

When ordering parts, please specify:

- All Nameplate Data
- Part Description
- Item Number
- Part Material

Recommended Spare Pilot valve sub-assembly (Part of item 5) for model CSM11-A2-2, Standard materials, P/N 18053K

•Recommend Factory repair or replace pilot valve when worn.

CSMII CONTROL ASSEMBLY						SOLENOID ASSEMBLY & COILS	
VOLTAGE	CSMII-A2-2		CSMII-N2-4	CSMII-CZ2-4	CSMII-CQ2-4	SOLENOID PART No.	COIL PART No.
	STANDARD	SEA-WATER SERVICE	STANDARD	STANDARD	STANDARD		
	STOCK No.	STOCK No.	STOCK No.	STOCK No.	STOCK No.		
24/60 Hz	10023-01J	—	10031-01B	10039-01E	10038-01G	87573-01A	73342J
115/60 Hz	10023-02G	10046-01K	10031-02K	10039-02C	10038-02E	—	—
120/60 Hz	10023-02G	10046-01K	10031-02K	10039-02C	10038-02E	87573-02J	73343G
208/60 Hz	10023-03E	—	10031-03H	10039-03A	10038-03C	87573-03G	73344E
230/60 Hz	10023-04C	—	10031-04F	10039-04J	—	—	—
240/60 Hz	10023-04C	—	10031-04F	10039-04J	10038-04A	87573-04E	73345B
440/60 Hz	10023-09B	—	10031-09E	10039-09H	10038-09K	87573-09D	82542C
460/60 Hz	10023-05K	—	10031-05C	10039-05F	—	—	—
480/60 Hz	10023-05K	—	10031-05C	10039-05F	10038-05H	87573-05B	73346K
110/50 Hz	10023-06H	—	10031-06A	10039-06D	10038-06K	87573-06K	73347H
220/50 Hz	10023-07F	—	10031-07J	10039-07B	10038-07D	87573-07H	73348F
240/50 Hz	10023-08D	—	10031-08G	10039-08K	10038-08B	87573-08F	73349D

The solenoid is rated for continuous duty. It can be held energized continuously in normal ambient temperatures without overheating. Solenoid overheating is often due to over voltage conditions. AC voltage solenoids should not be used with less than 85% of rated voltage.

Solenoid Protection

If a solenoid is mechanically blocked in the energized position the coil soon burns out. Protect it with a "slow blow" fuse with an ampere rating of 1.5 times the solenoid "holding" current shown. Solenoid ratings are based on 115 VAC where holding current is 0.6 amp and solenoid VA rating is 69 volt amperes. Current for other voltages is inversely proportional to voltage.

Examples: A.) Given 115 VAC supply to the solenoid, then 1.5 times .6 = .9 Amp. Select one amp slow blow fuse. B.) Given 24 VAC supply to the solenoid, then 1.5 times 2.88 = 4.32 Amp. Select 4.5 Amp slow blow fuse. C.) Given 240 VAC supply to the solenoid, then 1.5 times 0.288 = 0.432 Amp. Select 0.5 Amp slow blow fuse.

Volts	Amperes		Coil Resistance
	Holding	Inrush	Ohms
(AC 60 Hz)			
24	2.88	25.4	0.5
120	.575	5.1	14.1
208	.330	2.93	40
240	.288	2.54	58
440	.156	1.38	174
480	.143	1.27	233
Volts	Amperes		Coil Resistance
(AC 50 Hz)	Holding	Inrush	Ohms
110	.48	4.6	15.7
220	.24	2.3	66
240	.22	2.1	88



— MODELS — **X105L**
X105L2

Limit Switch Assemblies

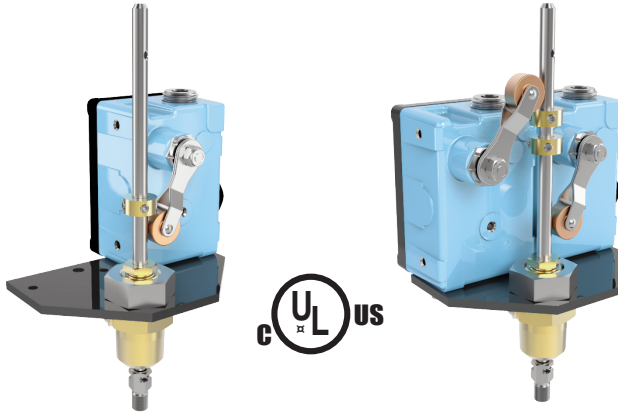

- **UL/ULC Listed**
- **Positive Action**
- **Rugged and Dependable**
- **Weather Proof or Explosion Proof**
- **Easy To Adjust**

The Cla-Val Model X105L/X105L2 Limit Switch Assembly is a rugged, dependable and positive acting switch assembly actuated by the opening or closing of a Cla-Val control valve on which it is mounted. The single pole, double throw micro switch can be connected either to open or to close an electrical circuit when actuated. By loosening the allen screw on the actuating collar and raising or lowering the collar on the stem, the X105L is easily adjusted to signal that the valve has fully reached the desired position (open or closed).

Installation

Single Pole Double Throw Switch

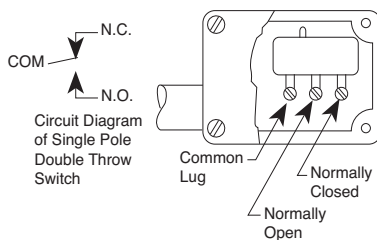

Double Pole Double Throw Switch

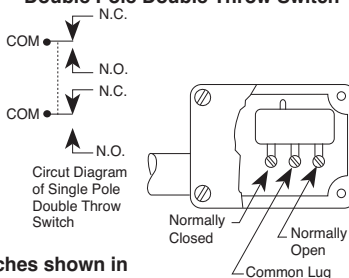

Switches shown in unactivated position.

1. Remove plug in top of valve cover.
2. Screw actuating stem into main valve stem.
3. Slip adapter down over stem and screw into place on valve cover.
4. Attach micro switch housing and bracket to adapter with jam nut.
5. Bring electrical supply circuit into unit through the 1/2" tapping in micro switch housing.
6. Adjust switch collars. (Set collar to trip switch after valve is positioned fully open or fully closed)

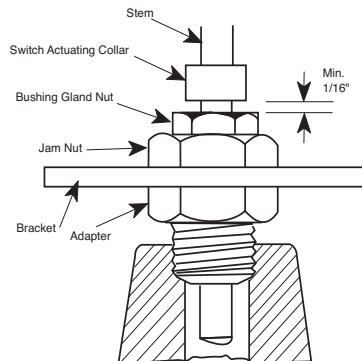

Actuating Collar Adjustment Minimum Setting

When adjusting actuating collar for proper switch action, a clearance of at least 1/16" (1/8" for 48" valve) must be provided between the collar and the bushing gland nut when valve is in the fully closed position.

Purchase Specifications

The assembly shall be bracket-mounted to exterior of an adapter attached to the center of the main valve cover. A stainless steel actuating stem with a swivel adapter shall be fastened directly to the main valve stem and move vertically through an adapter and gland with two O-ring seals as the valve moves. An adjustable collar located on the actuating stem shall actuate the sensor arm of a switch when valve has fully reached the open or closed (specify) position. The rotary-type position sensor arm shall actuate SPDT or DPDT type (specify) micro-switches mounted inside protective housing either weather-tight or explosion-proof NEMA rated (specify).

Provisions shall be made for bleeding air from valve cover through a small bleed screw and washer located on one wrench flat of adapter. All assemblies shall be capable of accommodating up to three switches. Standard materials in contact with operating fluid are brass, stainless steel, Monel and Buna-N.

A conduit hub opening in the switch enclosure shall be provided for attaching protective weatherproof conduit for the electrical switch wires (wiring and conduit supplied by others). A sealing plug shall be provided to protect conduit opening during shipping or storage.

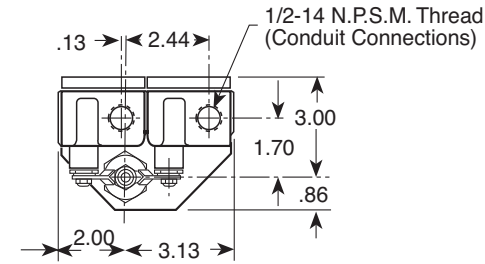

Fig. 1
Valve Size
1 1/4" Thru 8"
X105L2W
X105L2X

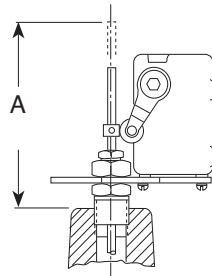

Fig. 2
Valve Size
1 1/4" Thru 14"
X105LCW
X105LCX

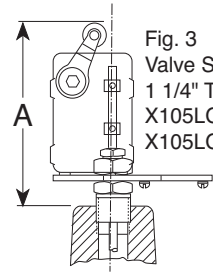

Fig. 3
Valve Size
1 1/4" Thru 8"
X105LOW
X105LOX

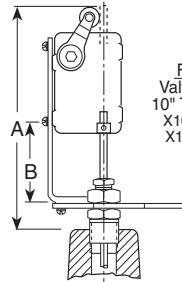

Fig. 4
Valve Size
10" Thru 14"
X105LOW
X105LOX

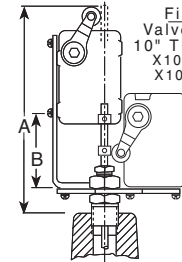
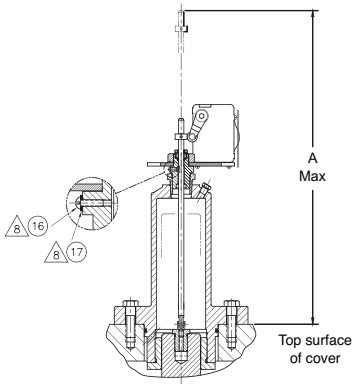
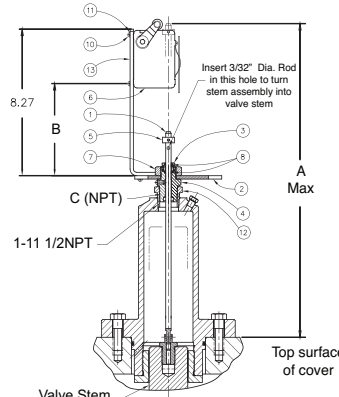

Fig. 5
Valve Size
10" Thru 14"
X105L2W
X105L2X



20" & 24" Size
X105LCW & X105LCX



20" & 24" Size
X105LOW

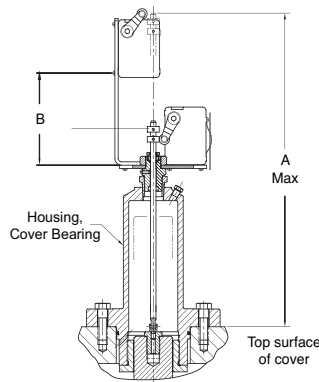

16" Thru 48" Size
X105L2W

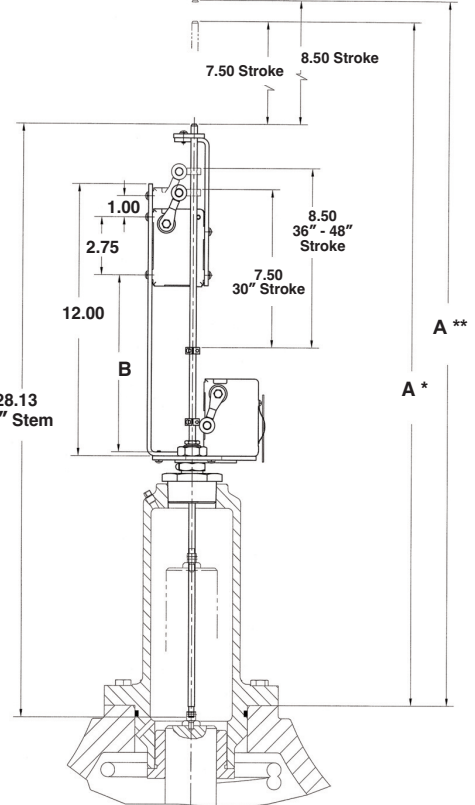

A* - 30" • A** - 36", 42" & 48" Size

X105 Series Dimensions (In Inches)

BasicValve 100-01	1 1/4	1 1/2	2	2 1/2	3	4	6	8	10	12	14	16	18	20	24	30	36*	42*	48*
Dimension "A"	10.19	10.19	7.16	7.16	7.34	7.00	6.69	6.91	9.88	9.59	9.16	10.78	10.78	18.23	19.10	35.07	36.07	36.07	36.07
Dimension "B"							1.69	1.69	2.44	2.94	2.94	2.94	2.94	4.32	5.19	8.40	8.40	8.40	8.40
C (NPT)	1/4	1/4	1/2	1/2	1/2	3/4	3/4	1	1	1 1/4	1 1/2	2	2	3/4	3/4	2	2	2	2
BasicValve 100-20					3	4	6	8	10	12	14	16	18	20	24	30	36*	42*	48*
Dimension "A"					7.16	7.34	7.00	6.69	6.91	9.88	9.59	9.59	10.78	10.78	10.78	11.30	35.07	36.07	36.07
Dimension "B"								1.69	1.69	2.44	2.94	2.94	2.94	2.94	2.94	5.19	8.40	8.40	8.40
C (NPT)					1/2	1/2	3/4	3/4	1	1	1 1/4	1 1/4	2	2	2	1	2	2	2



X105L

Limit Switch Assembly

Parts list shown is for sizes 16" and smaller.
Please consult factory for parts on sizes 18",
20", 24", 30", 36", 42" and 48".

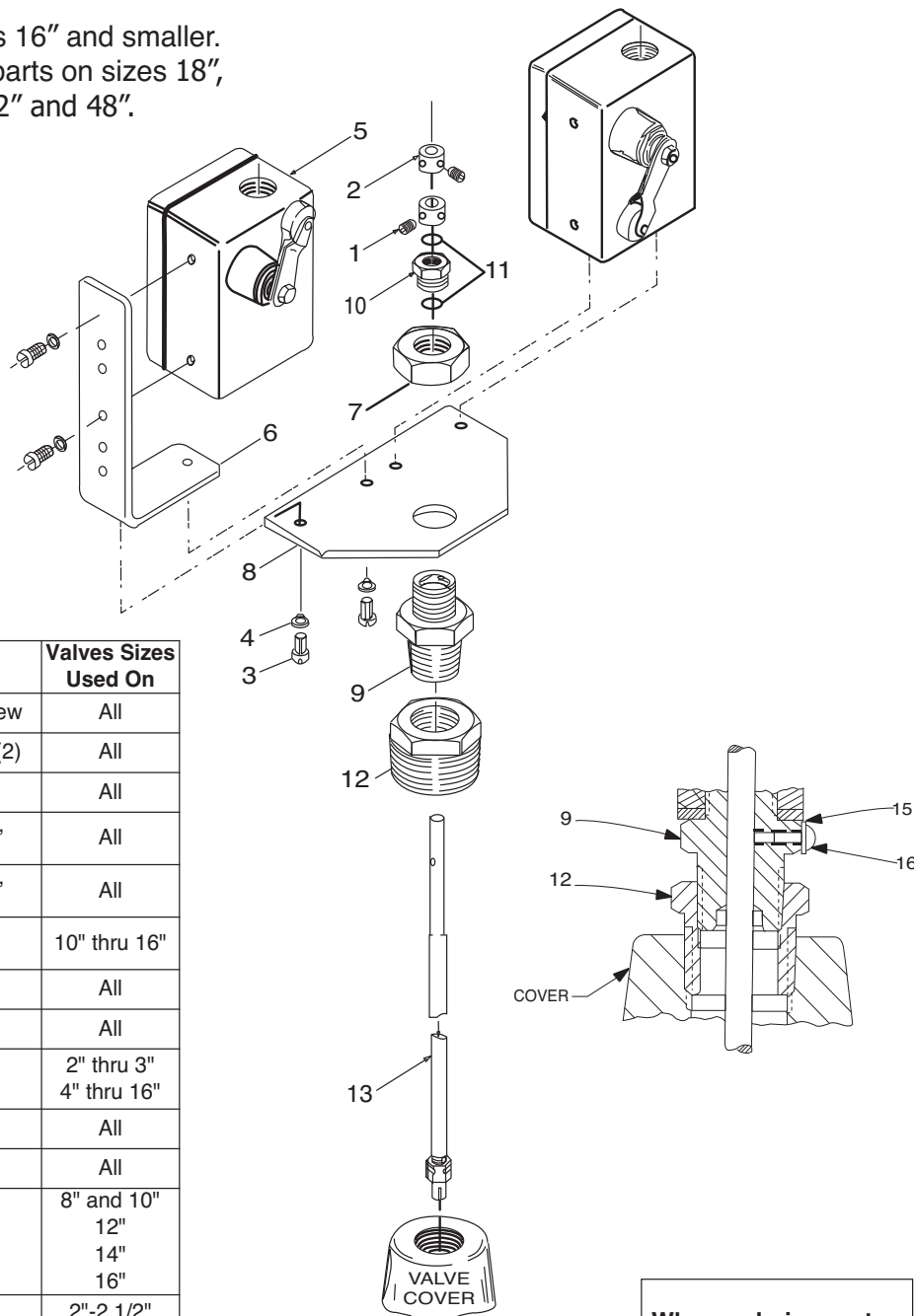

Item	Part Number	Description	Valves Sizes Used On
1-2	20441701E	Collar W/Set Screw	All
3	67578-21B	Screw, Machine (2)	All
4	67584-23F	Washer, Lock (2)	All
5	34637K	Switch Assembly, Weather Proof	All
	34633J	Switch Assembly, Explosion Proof	All
6	64310G	Bracket Switch Mounting	10" thru 16"
7	67815-06J	Nut, Jam	All
8	63674G	Plate, Mounting	All
9	2838201J	Adapter	2" thru 3"
	2838202G	Adapter	4" thru 16"
10	63398C	Bushing, Gland	All
11	00951E	O-Ring (2)	All
12	6764417K	Bushing	8" and 10"
	6764418H	Bushing	12"
	6764419F	Bushing	14"
	6764491J	Bell Reducer	16"
13	8970101F	Stem, Actuating	2"-2 1/2"
	8970102D	Stem, Actuating	3"-4"
	8970103B	Stem, Actuating	6"-8"
	8970104K	Stem, Actuating	10"-12"-14"
	8970105G	Stem, Actuating	16"
15	6551201H	Fiber Washer	All
16	6824421K	Screw 8-32 x 3/8	All

When ordering parts, please specify:

- Item Number
- Description
- Part Number

Typical Applications

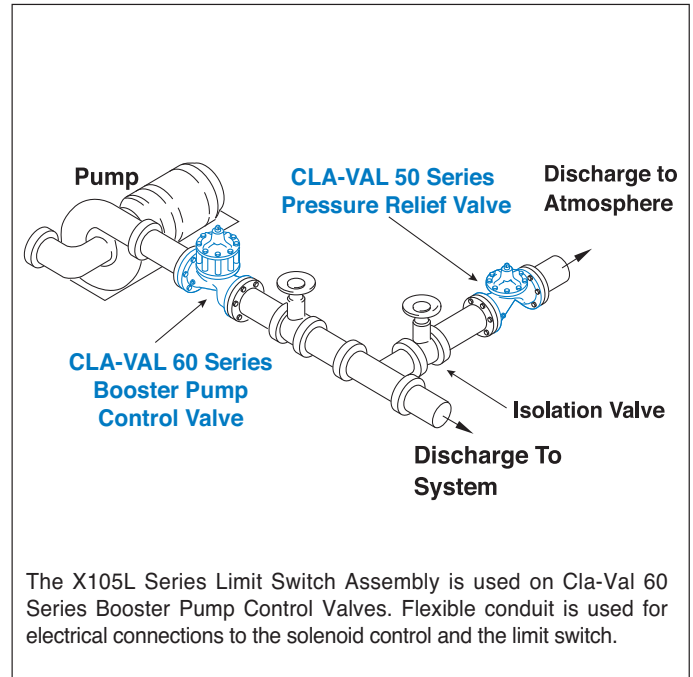
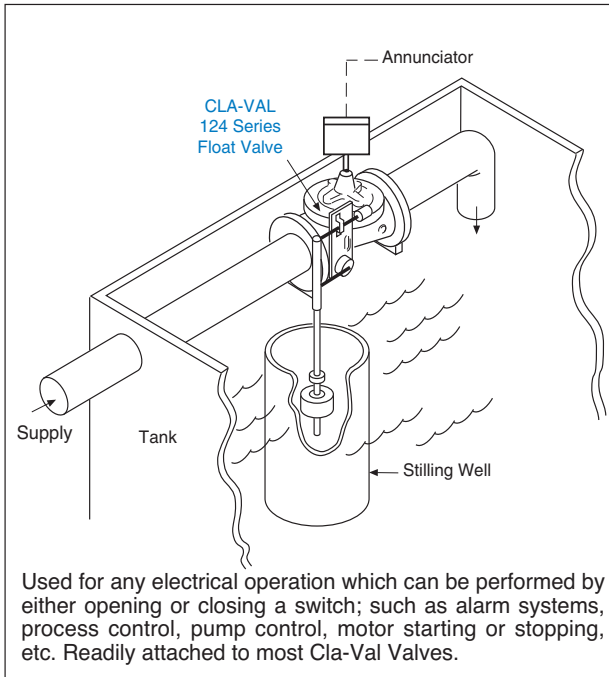

Specifications

Materials: Aluminum switch housing
Steel bracket and brass adapter
Stainless steel stem

Electrical: 1/2" Conduit connection

Switch Type: SPDT UL, File No. E12252,
CSA Certified, File No. LR57325
Weather proof
NEMA 1,3,4, and13

Switch Rating: UL/CSA rating: L96
15 amp. 125, 250, or 480 volts AC
1/2 amp. 125 volts DC
1/4 amp. 250 volts DC

Switch Options: DPDT switches available on request
UL/CSA Rating: L59, 10 amps

Explosion proof micro switches are
NEMA 1,7, and 9
UL Listed, File No. E14274 and CSA
Certified, File No. LR57324: Class I,
Group C and D and Class II, Group
E, F and G.

When Ordering, Please Specify

1. Valve Size and Basic Valve Model Number
2. Catalog Number from Table Below
3. All Valve Name Plate Data
4. Select Single or Double Pole Switch
5. Explosion Proof or Weather Proof Type Enclosure
6. Amperes and Voltage, AC or DC
7. Actuating Position (Valve Open or Closed)

CATALOG NO.	ACTUATION POSITION	SWITCH ENCLOSURE
X105LCW	Valve Closed	Weather Proof
X105LCX	Valve Closed	Explosion Proof
X105LOW	Valve Open	Weather Proof
X105LOX	Valve Open	Explosion Proof
X105L2W	Dual	Weather Proof
X105L2X	Dual	Explosion Proof



CLA-VAL

1701 Placentia Avenue • Costa Mesa, CA 92627

800-942-6326 • Fax: 949-548-5441 • Web Site: cla-val.com • E-mail: info@cla-val.com

CLA-VAL CANADA

4687 Christie Drive
Beamsville, Ontario
Canada L0R 1B4
Phone: 905-563-4963
E-mail sales@cla-val.ca

CLA-VAL EUROPE

Chemin des Mésanges 1
CH-1032 Romanel/
Lausanne, Switzerland
Phone: 41-21-643-15-55
E-mail: cla-val@cla-val.ch

CLA-VAL UK

Dainton House, Goods Station Road
Tunbridge Wells
Kent TN1 2 DH England
Phone: 44-1892-514-400
E-mail: info@cla-val.co.uk

CLA-VAL FRANCE

Porte du Grand Lyon 1
ZAC du Champ du Pérignon
France - 01700 Neyron
Phone: 33-4-72-25-92-93
E-mail: cla-val@cla-val.fr

CLA-VAL PACIFIC

45 Kennaway Road
Woolston, Christchurch, 8023
New Zealand
Phone: 64-39644860
www.cla-valpacific.com
E-mail: info@cla-valpacific.com



Model X105L LIMIT SWITCH ASSEMBLY

PARTS LIST

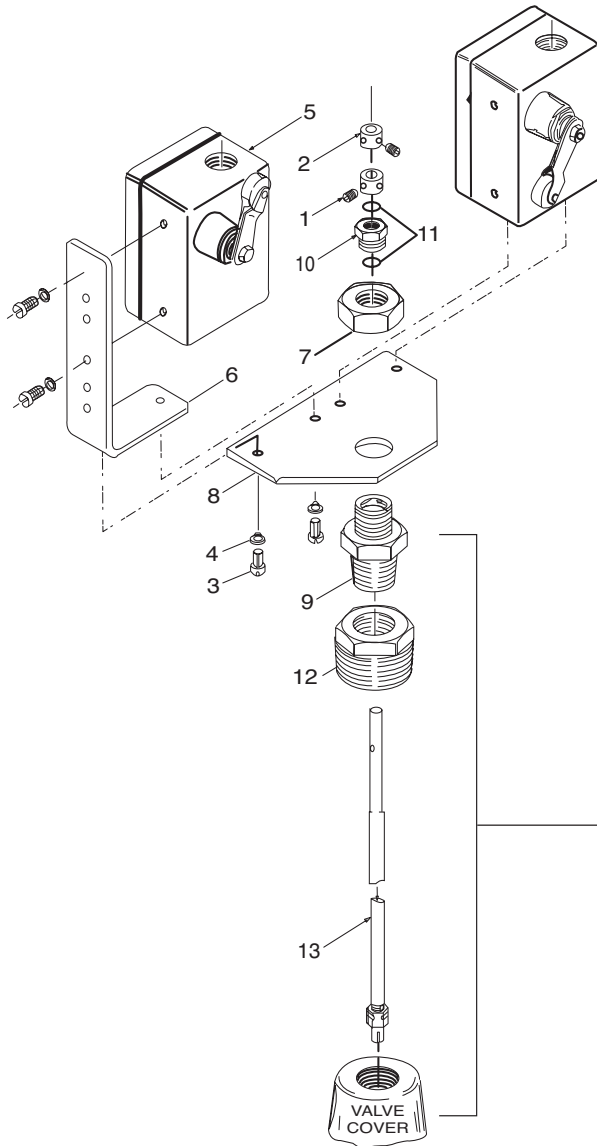

Item No.	Description	Valve Sizes Used On
1-2	Collar with Set Screw	All
3	Screw, Machine (2)	All
4	Washer, Lock (2)	All
5	Switch Assembly, Weather Proof Switch Assembly, Explosion Proof	All
6	Bracket, Switch Mounting	10" - 16"
7	Nut, Jam	All
8	Plate, Mounting	All
9	Adapter Assembly (incl: 15 & 16) Adapter Assembly (incl: 15 & 16)	2" - 3" 4" - 16"
10	Bushing, Gland	All
11	O-Ring (2)	All
12	Bushing, Bell Reducer	8" - 10", 12", 14", & 16"
13	Stem, Actuating	2" - 2-1/2", 3", 4", 6", 7", 8", & 10" - 16"
15	Fiber Washer	All
16	Screw 8-32 x 3/8	All

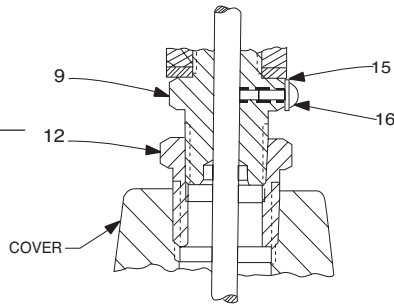

When Ordering, Please Specify

1. All Nameplate data
2. Item Number
3. Description
4. Material



Flow Control

Model CVS-1



- No Lubrication
- Corrosion Resistant
- One Moving Part
- Replaceable Teflon Coated Seal
- Fast Acting, Non-Sticking
- Easy Maintenance

The CVS-1 Shuttle Valve is precision engineered for lasting dependable service. The CVS-1 combines instantaneous action with one moving part designed for smooth positive operation with minimum wear. The flow pattern interconnects the highest pressure from two separate pressure zones (ports "A" or "B") to a common port "C". The two pressure zones, ports A or B can never flow to one another.

The design incorporates precision sealing required for low pressure or high pressure operation. The seal is teflon coated to prevent sticking under the most adverse conditions of exposure or prolonged actuation in one position. The CVS-1 Shuttle Valve incorporates all the required features for lasting dependable service.

Specifications

Size	3/8"
End Detail	3/8" NPT — Three Female Connections
Pressure Rating	400 psi Max.
Shifting Differential	10" Water Column Differential
CV Factor	"A" to "C" 3.5 "B" to "C" 3.1
Temperature Range	Water to 140°F
Materials	Body Cast Bronze ASTM B-62 Internal Trim Delrin Rubber Parts Static Seal Buna-N® Synthetic Rubber Shuttle Seal Buna-N® Synthetic Rubber Teflon Coated

Dimensions

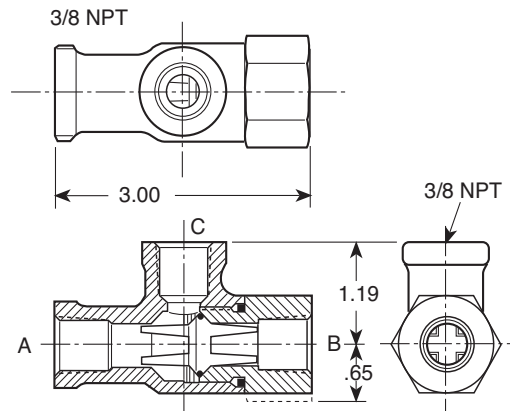

Principle of Operation

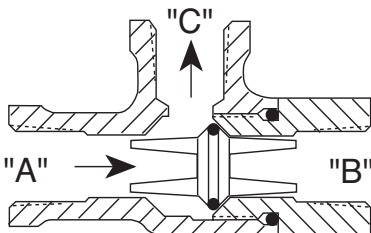

Flow Direction "A" to "C"

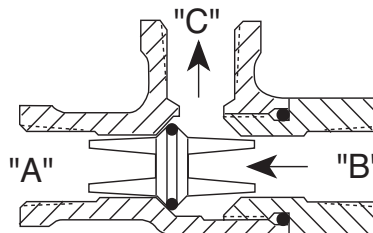

Flow Direction "B" to "C"

When Ordering, Please Specify

1. Catalog Number
2. Minimum-maximum line pressure
3. Fluid to be handled
4. Temperature
5. Materials



Model X46

PRESSURE REDUCING CONTROL

- Self Scrubbing Cleaning Action
- Straight Type or Angle Type

The Cla-Val Model X46 Strainer is designed to prevent passage of foreign particles larger than 0.015". It is especially effective against such contaminant as algae, mud, scale, wood pulp, moss, and root fibers. There is a model for every Cla-Val valve.

The X46 Flow Clean strainer operates on a velocity principle utilizing the circular "air foil" section to make it self cleaning. Impingement of particles is on the "leading edge" only. The low pressure area on the downstream side of the screen prevents foreign particles from clogging the screen. There is also a scouring action, due to eddy currents, which keeps most of the screen area clean.

INSTALLATION

The strainer is designed for use in conjunction with a Cla-Val Main Valve, but can be installed in any piping system where there is a moving fluid stream to keep it clean. When it is used with the Cla-Val Valve, it is threaded into the upstream body port provided for it on the side of the valve. It projects through the side of the Main Valve into the flow stream. All liquid shunted to the pilot control system and to the cover chamber of the Main Valve passes through the Model X46 Flow Clean Strainer.

INSPECTION

Inspect internal and external threads for damage or evidence of cross-threading. Check inner and outer screens for clogging, embedded foreign particles, breaks, cracks, corrosion, fatigue, and other signs of damage.

DISASSEMBLY

Do not attempt to remove the screens from the strainer housing.

CLEANING

After inspection, cleaning of the Model X46 can begin. Water service usually will produce mineral or lime deposits on metal parts in contact with water. These deposits can be cleaned by dipping Model X46 in a 5-percent muriatic acid solution just long enough for deposit to dissolve. This will remove most of the common types of deposits.

CAUTION: use extreme care when handling acid. If the deposit is not removed by acid, then a fine grit (400) wet or dry sandpaper can be used with water. Rinse parts in water before handling. An appropriate solvent can clean parts used in fueling service. Dry with compressed air or a clean, lint-free cloth.

Protect from damage and dust until reassembled.

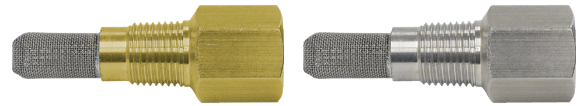

Model X46A Straight

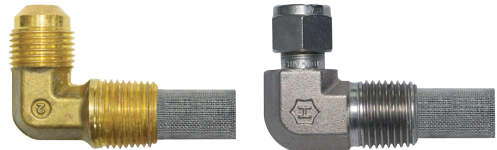

Model X46B Angle

REPLACEMENT

If there is any sign of damage, or if there is the slightest doubt that the Model X46 Flow Clean Strainer may not afford completely satisfactory operation, replace it. Use Inspection steps as a guide. Neither inner screen, outer screen, nor housing is furnished as a replacement part. Replace Model X46 Flow Clean Strainer as a complete unit.

When ordering replacement Flow-Clean Strainers, it is important to determine pipe size of the tapped hole into which the strainer will be inserted (refer to column A or F), and the size of the external connection (refer to column B or G).



Dimensions (in Inches)

X46 Straight Type A (In Inches)						
A (NPT)	C (NPT)	D	E	F	G	I
1/8	1/8	1-3/4	3/4	1/2	1/2	1/4
1/4	1/4	2-1/4	1	3/4	3/4	3/8
3/8	3/8	2-1/2	1	7/8	7/8	1/2
3/8	1/2	2-1/2	1-1/4	1/2	7/8	3/4
1/2	1/2	3	1-1/4	1	1-1/8	3/4
3/8	3/4	3-3/8	2	1/2	1	7/8
3/4	3/4	4	2	1	1-1/2	7/8
3/8	1	4-1/4	2-3/4	1/2	1-3/8	7/8
1	1	4-1/2	2-3/4	1-1/4	1-3/4	7/8
1/2	1	4-1/4	2-3/4	1/2	1-3/8	7/8

X46 Angle Type B (In Inches)					
B (NPT)	C (SAE)	D	E	H	I
1/8	1/4	1-3/8	5/8	7/8	1/4
1/4	1/4	1-3/4	3/4	1	3/8
3/8	1/4	2	7/8	1	1/2
3/8	3/8	1-7/8	7/8	1	1/2
1/2	3/8	2-3/8	1	1-1/4	5/8

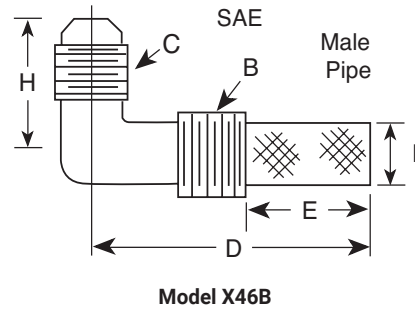
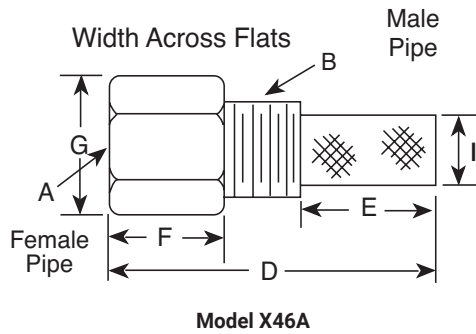

When Ordering, Please Specify

1. Catalog number X46
2. Straight or Angel Type
3. Size inserted into and size connection
4. Materials

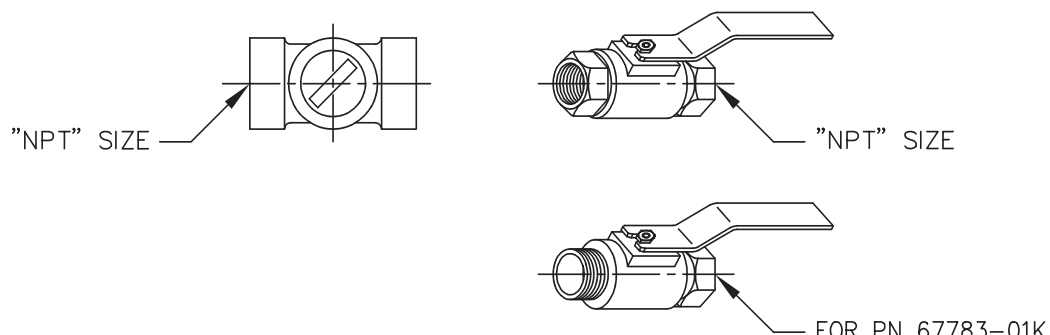

AK	07-10-08	AK	08-14-08	PC	10-1-2008	BB ADDED PN'S 67783-62B (NED 62200) BC ADDED PN'S 67783-63K (NED 62218) BD ADDED PN 67783-64H (NED 62446)		CATALOG NO.	DRAWING NO. 67783	REV BD				
	TYPE OF VALVE AND MAIN FEATURES							CK2 COCK/BALL VALVE		DESIGN				
								DRAWN	MGR	4-02-80	CHK'D	KD	4-03-80	APV'D
SCALE: NONE														
														
CLA-VAL PART NO. AND MATERIAL														
BRONZE WITH HANDLE	STEEL WITH HANDLE	IRON WITH HANDLE	316 SST WITH HANDLE	316 SST W/ LOCKING HANDLE	BRONZE WITH HANDLE	MONEL WITH HANDLE	MONEL W/ LOCKING HANDLE	SIZE "NPT"						
67783-01K*	-09C	-17F	-25J SUPSD BY-26G		-41F SUPSD BY-01K			1/8"						
-02H	-10A	-18D	-26G	-51E SUPSD BY-26G -52C	-42D SUPSD BY-02H		-55F	1/4"						
-03F * -59H***	-11J	-19B	-27E	-46E SUPSD BY-27E -53A	-45G -57B**	-48A SUPSD BY-49J	-63K	3/8"						
-04D -60F***	-12G	-20K	-28C	-54J	-43B SUPSD BY-04D	-49J	-62B	1/2"						
-05A -61D***	-13E	-21H	-29A	-64H	-44K SUPSD BY-05A	-56D		3/4"						
-06J	-14C	-22F	-30J			-58K		1"						
-07G	-15K	-23D	-31G					1 1/4"						
-08E	-16H	-24B	-32E					1 1/2"						
-50G			-47C					2"						
<p>* SEE ENGINEERING APPROVED VENDORS TABLE (SHEET 2 OF 2).</p> <p>** HAMMOND VALVE 8501 ONLY.</p> <p>*** WILKINS CK2 (SEE SHEET 2 OF 2)</p>														

"THIS DRAWING IS THE PROPERTY OF CLA-VAL CO. AND SAME AND COPIES MADE THEREOF, IF ANY, SHALL BE RETURNED TO IT UPON DEMAND. DELIVERY AND DISCLOSURE HEREOF ARE SOLELY UPON CONDITION THAT THE SAME SHALL NOT BE USED, COPIED OR REPRODUCED, NOR SHALL THE SUBJECT HEREOF BE DISCLOSED IN ANY MANNER TO ANYONE FOR ANY PURPOSE, EXCEPT AS HEREIN AUTHORIZED, WITHOUT PRIOR WRITTEN APPROVAL OF CLA-VAL CO. THIS DRAWING IS SUBMITTED CONFIDENTIALLY AND MAY NOT BE USED IN THE MANUFACTURE OF ANY MATERIAL OR PRODUCT OTHER THAN SUCH MATERIALS AND PRODUCTS FURNISHED TO CLA-VAL CO. WHETHER OR NOT THE EQUIPMENT OR INFORMATION SHOWN HEREON IS PATENTED OR OTHERWISE PROTECTED, FULL TITLE AND COPYRIGHTS, IF ANY, IN AND TO THIS DRAWING AND/OR INFORMATION DELIVERED OR SUBMITTED ARE FULLY RESERVED CLA-VAL CO."



X43 Strainer

ITEM	DESCRIPTION	MATERIAL
1	Pipe Plug	Stainless Steel
2	Strainer Plug	Stainless Steel
3	Gasket	Fiber
4	Screen	Stainless Steel
5	Body	Stainless Steel

No parts available. Replacement assembly only.

Standard 60 mesh pilot system strainer for fluid service.

Size	Stock Number
3/8 x 3/8	8850604D

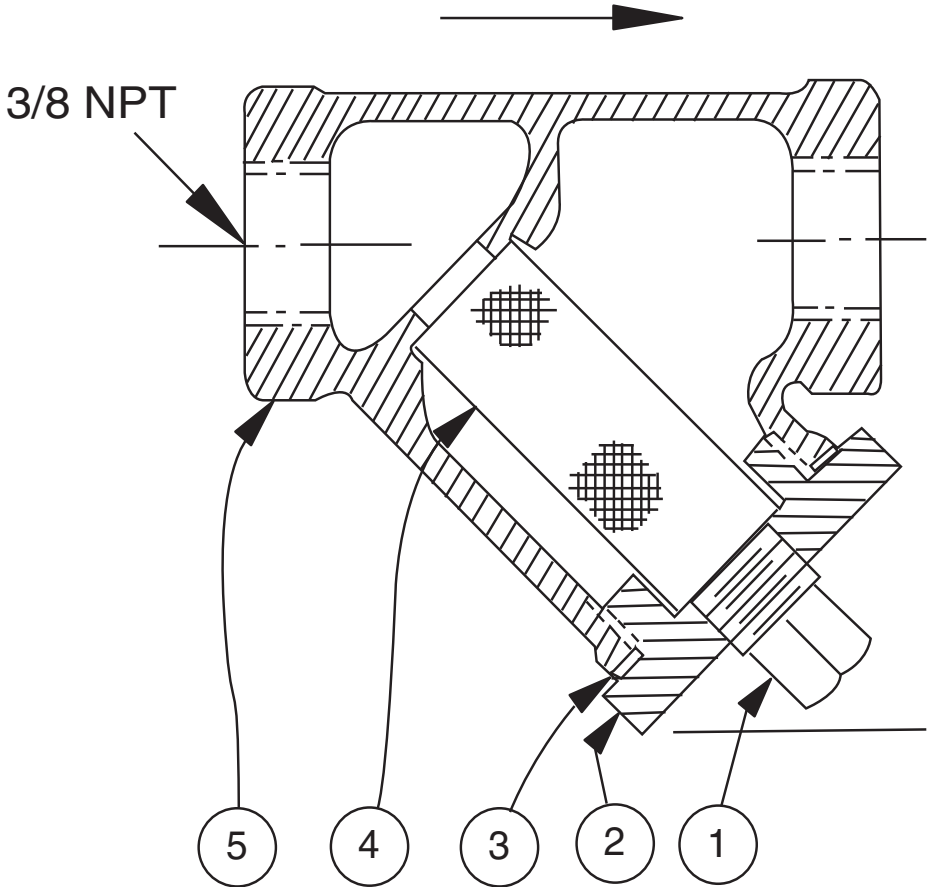



Cla-Val Product ID

HOW TO ORDER

PROPER IDENTIFICATION

For ordering repair kits, replacement parts, or for inquiries concerning valve operation, it is important to properly identify Cla-Val products already in service by including all nameplate data with your inquiry. Pertinent product data includes valve function, size, material, pressure rating, end details, type of pilot controls used and control adjustment ranges.

IDENTIFICATION PLATES

For product identification, cast-in body markings are supplemented by identification plates as illustrated on this page. The plates, depending on type and size of product, are mounted in the most practical position. **It is extremely important that these identification plates are not painted over, removed, or in any other way rendered illegible.**



This brass plate appears on altitude valves only and is found on top of the outlet flange.

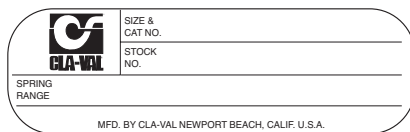

This tag is affixed to the cover of the pilot control valve. The adjustment range appears in the spring range section.

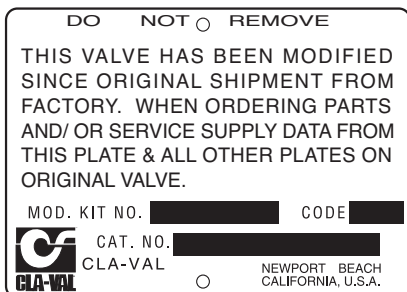

This aluminum plate is included in pilot system modification kits and is to be wired to the new pilot control system after installation.

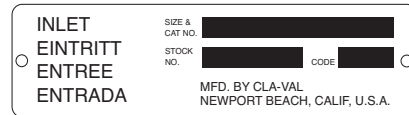

This brass plate appears on valves sized 2 1/2" and larger and is located on the top of the inlet flange.

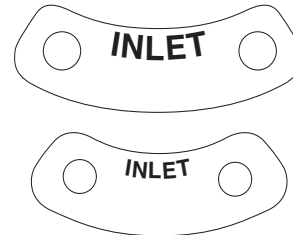

These two brass plates appear on 3/8", 1/2", and 3/4" size valves and are located on the valve cover.

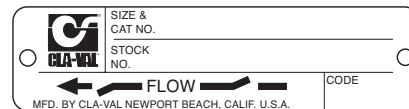

These two brass plates appear on threaded valves 1" through 3" size or flanged valves 1" through 2". It is located on only one side of the valve body.

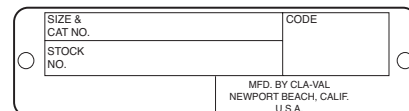

This brass plate is used to identify pilot control valves. The adjustment range is stamped into the plate.

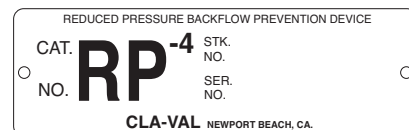

This brass plate is used on our backflow prevention assemblies. It is located on the side of the Number Two check (2" through 10"). The serial number of the assembly is also stamped on the top of the inlet flange of the Number One check.

How to Order

Because of the vast number of possible configurations and combinations available, many valves and controls are not shown in published product and price lists. For ordering information, price and availability on product that are not listed, please contact your local Cla-Val office or our factory office located at:

P. O. Box 1325
Newport Beach, California 92659-0325
(949) 722-4800
FAX (949) 548-5441



When Ordering, Please Specify

- | | | | | |
|---------------------------|--------------------------------------|------------------------|----------------------------|----------------------|
| 1. Model Number | 3. Adjustment range (as application) | 4. Valve Size | 6. Body and Trim Materials | 7. Optional Features |
| 2. Globe or Angle Pattern | | 5. Threaded or Flanged | | 8. Pressure Class |

Unless Otherwise Specified

- Globe or angle pattern are the same price
- Ductile iron body and bronze trim are standard
- X46 Flow Clean Strainer or X43 "Y" Strainer are included
- CK2 Isolation Valves are included in price on 4" and larger valve sizes (6" and larger on 600 Series)

Limited Warranty

Automatic valves and controls as manufactured by Cla-Val are warranted for three years from date of shipment against manufacturing defects in material and workmanship that develop in the service for which they are designed, provided the products are installed and used in accordance with all applicable instructions and limitations issued by Cla-Val. Electronic components manufactured by Cla-Val are warranted for one year from the date of shipment.

We will repair or replace defective material, free of charge, that is returned to our factory, transportation charges prepaid, if upon inspection, the material is found to have been defective at time of

original shipment. This warranty is expressly conditioned on the purchaser's providing written notification to Cla-Val immediate upon discovery of the defect.

Components used by Cla-Val but manufactured by others, are warranted only to the extent of that manufacturer's guarantee.

This warranty shall not apply if the product has been altered or repaired by others, Cla-Val shall make no allowance or credit for such repairs or alterations unless authorized in writing by Cla-Val.

Disclaimer of Warranties and Limitations of Liability

The foregoing warranty is exclusive and in lieu of all other warranties and representations, whether expressed, implied, oral or written, including but not limited to any implied warranties or merchantability or fitness for a particular purpose. All such other warranties and representations are hereby canceled.

Cla-Val shall not be liable for any incidental or consequential loss, damage or expense arising directly or indirectly from the use of the

product. Cla-Val shall not be liable for any damages or charges for labor or expense in making repairs or adjustments to the product. Cla-Val shall not be liable for any damages or charges sustained in the adaptation or use of its engineering data and services. No representative of Cla-Val may change any of the foregoing or assume any additional liability or responsibility in connection with the product. The liability of Cla-Val is limited to material replacements F.O.B. Newport Beach, California.

Terms of Sale

ACCEPTANCE OF ORDERS

All orders are subject to acceptance by our main office at Newport Beach, California.

CREDIT TERMS

Credit terms are net thirty (30) days from date of invoice.

PURCHASE ORDER FORMS

Orders submitted on customer's own purchase order forms will be accepted only with the express understanding that no statements, clauses, or conditions contained in said order form will be binding on the Seller if they in any way modify the Seller's own terms and conditions of sales.

PRODUCT CHANGES

The right is reserved to make changes in pattern, design or materials when deemed necessary, without prior notice.

PRICES

All prices are F.O.B. Newport Beach, California unless expressly stated otherwise on our acknowledgment of the order. Prices are subject to change without notice. The prices at which any order is accepted are subject to adjustment to the Seller's price in effect at the time of shipment. Prices do not include sales, excise, municipal, state or any other Government taxes. Minimum order charge \$100.00.

RESPONSIBILITY

We will not be responsible for delays resulting from strikes, accidents, negligence of carriers, or other causes beyond our control. Also, we will not be liable for any unauthorized product alterations or charges accruing there from.

RISK

All goods are shipped at the risk of the purchaser after they have been delivered by us to the carrier. Claims for error, shortages, etc., must be made upon receipt of goods.

EXPORT SHIPMENTS

Export shipments are subject to an additional charge for export packing.

RETURNED GOODS

1. Customers must obtain written approval from Cla-Val prior to returning any material.
2. Cla-Val reserves the right to refuse the return of any products.
3. Products more than six (6) months old cannot be returned for credit.
4. Specially produced, non-standard models cannot be returned for credit.
5. Rubber goods such as diaphragms, discs, o-rings, etc., cannot be returned for credit, unless as part of an unopened vacuum sealed repair kit which is less than six months old.
6. Goods authorized for return are subject to a 35% (\$100 minimum) restocking charge and a service charge for inspection, reconditioning, replacement of rubber parts, retesting, repainting and repackaging as required.
7. Authorized returned goods must be packaged and shipped prepaid to Cla-Val, 1701 Placentia Avenue, Costa Mesa, California 92627.





Model Repair Kits

Model 100-01 Hytrol Main Valve

BUNA-N MATERIAL				
	RUBBER KIT STOCK #	REPAIR KIT STOCK #	REBUILD ASSEMBLY STOCK #	STUD & NUT KIT STOCK #
3/8"	9169801K		21176614B	21176633J
1/2"	9169802H	21176602F	21176615A	21176634H
3/4"	9169802H	21176602F	21176615A	21176634H
1" Non-Guided	9169803F	21176601G	21176616K	21176636F
1"	9169804D	21176603E	21176617J	21176636F
1 1/4"	9169804D	21176603E	21176617J	21176636F
1 1/2"	9169804D	21176603E	21176617J	21176636F
2"	9169805A	21176608K	21176618H	21176637E
2 1/2"	9169811J	21176609J	21176619G	21176638D
3"	9169812G	21176604D	21176620D	21176639C
4"	9169813E	21176605C	21176621C	21176640K
6"	9169815K	21176606B	21176622B	21176641J
8"	9817901D	21176607A	21176623A	21176642H
10"	9817902B	21176610F	21176654C	21176643G
12"	9817903K	21176611E	21176625J	21176644F
14"	9817904H	21176612D	21176626H	21176645E
16"	9817905E	21176613C	21176627G	21176645E

Model 100-20 Hytrol Main Valve

BUNA-N MATERIAL				
	RUBBER KIT STOCK #	REPAIR KIT STOCK #	REBUILD ASSEMBLY STOCK #	STUD & NUT KIT STOCK #
3"	9169805A	21176608K	21176618H	21176637E
4"	9169812G	21176604D	21176620D	21176639C
6"	9169813E	21176605C	21176621C	21176640K
8"	9169815K	21176606B	21176622B	21176641J
10"	9817901D	21176607A	21176623A	21176642H
12"	9817902B	21176610F	21176624K	21176643G
14"	9817903K	21176611E	21176625J	21176644F
16"	9817903K	21176611E	21176625J	21176644F

Model 100-30 Hytrol Main Valve

BUNA-N MATERIAL		
	RUBBER KIT STOCK #	REBUILD ASSEMBLY STOCK #
2 1/2"	21112704H	21235401C
3"	21112702K	21235402B
4"	21112703J	21235403A
6"	27496886J	21235404K
8"	21112701A	21235405J
10"	CF	21235406H

- Rubber Kit Includes:** Diaphragm, Disc, Spacer Washers. **Model 100-30 also includes:** Stem O-Ring, Seal, Bearing O-Ring.
- Repair Kit Includes:** Diaphragm, Disc, Spacer Washers, Epoxy Coated Disc Retainer, Epoxy Coated Diaphragm Washer, Protective Washer
- Rebuild Assembly Includes:** Diaphragm, Disc, Spacer Washers, Epoxy Coated Disc Retainer, Epoxy Coated Diaphragm Washer, Protective Washer, Stainless Steel Bolts & Washers (6" & Below), Stainless Steel Studs, Nuts, & Washers (8" & Above), Stem, Stem Nut, Disc Guide, Standard Cover Spring, Cover Washer. **Model 100-30 also includes:** Upper and Lower Stem and Stem Nut, Stem O-Ring, Seal, Lower Spring, PU Bearing, Bearing O-Ring, Bearing Retainer Ring.
- Stud & Nut Kit Includes:** Stainless Steel Bolts & Washers (6" & Below), Stainless Steel Studs, Nuts, & Washers (8" & Above)



Repair Kits for 100-02/100-21 Powertrol and 100-03/100-22 Powercheck Main Valves

For: Powertrol and Powercheck Main Valves—150 Pressure Class Only

Includes: Diaphragm, Disc (or Disc Assembly) and O-rings and full set of spare Spacer Washers.

Valve Size	Kit Stock Number		Valve Size	Kit Stock Number	
	100-02			100-02 & 100-03	100-21 & 100-22
3/8"	9169901H		2 1/2"	9169910J	N/A
1/2" & 3/4"	9169902F		3"	9169911G	9169905J
1"	9169903D		4"	9169912E	9169911G
1 1/4" & 1 1/2"	9169904B		6"	9169913C	9169912E
2"	9169905J		8"	9169950E	9169913C
			10"	9169939H	9169950E
			12"	9169937B	9169939H

Consult factory for larger sizes

Repair Kits for 100-04/100-23 Hy-Check Main Valves

For: Hy-Check Main Valves—150 Pressure Class Only

Includes: Diaphragm, Disc and O-Rings and full set of spare Spacer Washers.

Valve Size	Kit Stock Number		Valve Size	Kit Stock Number	
	100-04	100-23		100-04	100-23
4"	20210901B	N/A	12"	20210905H	20210904J
6"	20210902A	20210901B	14"	20210906G	N/A
8"	20210903K	20210902A	16"	20210907F	20210905H
10"	20210904J	20210903K	20"	N/A	20210907F
			24"	N/A	20210907F

Consult factory for larger sizes

Repair Kits for Pilot Control Valves (In Standard Materials Only)

Includes: Diaphragm, Disc (or Disc Assembly), O-Rings, Gaskets or spare Screws as appropriate.

BUNA-N® (Standard Material)				VITON (For KB Controls)	
Pilot Control	Kit Stock Number	Pilot Control	Kit Stock Number	Pilot Control	Kit Stock Number
CDB	9170006C	CFM-7A	1263901K	CDB-KB	9170012A
CDB-30	9170023H	CFM-9	12223E	CRA-KB	N/A
CDB-31	9170024F	CRA (w/bucking spring)	9170001D	CRD-KB (w/bucking spring)	9170008J
CDB-7	9170017K	CRD (w/bucking spring)	9170002B	CRL-KB	9170013J
CDH-2	18225D	CRD (no bucking spring)	9170003K	CDHS-2BKB	9170010E
CDHS-2	44607A	CRD-18	20275401K	CDHS-2FKB	9170011C
CDHS-2B	9170004H	CRD-22	98923G	CDHS-18KB (no bucking spring)	9170009G
CDHS-2F	9170005E	CRL (55F, 55L)	9170007A	102C-KB	1726202D
CDHS-3C-A2	24657K	CRL60/55L-60	9170033G		
CDHS-8A	2666901A	CRL60/55L60 1"	9170042H		
CDHS-18	9170003K	CRL-4A	43413E		
CDS-4	9170014G	CRL-5 (55B)	65755B		
CDS-5	14200A	CRL-5A (55G)	20666E		
CDS-6	20119301A	CRL-18	20309801C		
CDS-6A	20349401C	Universal CRL	9170041K		
CDS-7	20349402B	CV	9170019F		
CDS-7DO	20349403A	X105L (O-ring)	00951E		
CFCM-M1	1222301C	102B-1	1502201F	Buna-N®	
CFM-2	12223E	102C-2	1726201F	CRD Disc Ret. (Solid)	C5256H
CFM-7	1263901K	102C-3	1726201F	CRD Disc Ret. (Spring)	C5255K

Repair Assemblies (In Standard Materials Only)

Control	Description	Stock Number
CF1-C1	Pilot Assembly Only	89541H
CF1-CI	Complete Float Control less Ball and Rod	89016A
CFC2-C1	Disc, Distributor and Seals	2674701E
CSM 11-A2-2	Mechanical Parts Assembly	97544B
CSM 11-A2-2	Pilot Assembly Only	18053K
33A 1"	Complete Internal Assembly and Seal	2036030B
33A 2"	Complete Internal Assembly and Seal	2040830J

When ordering, please give complete nameplate data of the valve and/or control being repaired. MINIMUM ORDER CHARGE APPLIES