

CLA-VAL

AUTOMATIC CONTROL VALVES

60-32/660-32

Place this manual with personnel responsible
for maintenance of this valve

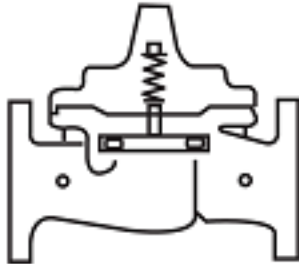

Installation

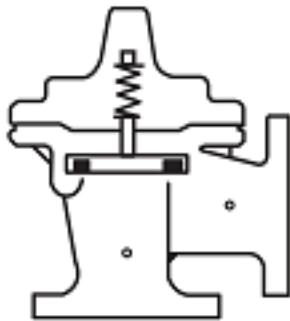

Operation

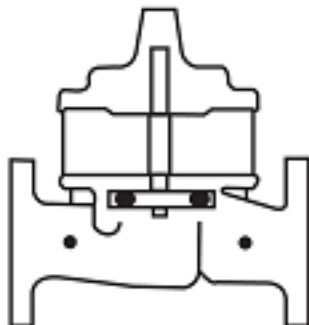

Maintenance



CLA-VAL • 1701 Placentia Avenue • Costa Mesa, CA 92627 • (949) 722-4800 • info@cla-val.com
CLA-VAL CANADA LTD. • 4687 Christie Drive • Beamsville, Ontario, LOR 1B4 Canada • (905) 563-4963

www.cla-val.com • info@cla-val.com



Recommended Inspections

Cla-Val recommends that an inspection be performed on our products annually. The inspection should include both a visual and functional test of the main valve/component and the pilot system. The inspection ensures that no damage or premature wear occurred due to velocity, pressure, or foreign matter within the fluid that may have exceeded the valve's design. Please consult the maintenance manual for specific information on the model. Manuals are available for download at Cla-Val.com, as well as contact information for a company representative.

Accurate record-keeping is a best practice for any preventative maintenance program, and Cla-Val strongly recommends this action through an asset management program. Cla-Val provides a free asset management tool, Link2Valves [Link2Valves - Cla-Val \(cla-val.com\)](http://Link2Valves - Cla-Val (cla-val.com)), to assist in preventative maintenance record-keeping and scheduling.

Hy-Check Valve

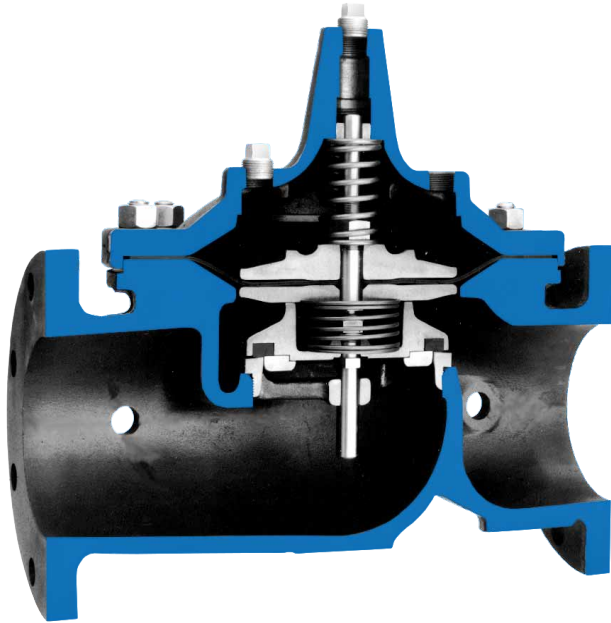

- Built-in Automatic Check Valve
- Drip Tight, Positive Seating
- Globe or Angle Pattern
- Service Without Removal From Line
- Every valve factory-tested

The Cla-Val Model 100-04 Hy-Check Valve is a hydraulically operated diaphragm valve with a built-in check feature to prevent return flow. Available in globe or angle pattern, it consists of a body, cover and diaphragm assembly. The diaphragm assembly which is guided top and bottom by a precision machined stem is the only moving part.

A synthetic rubber disc retained on three and one half sides forms a drip-tight seal with the renewable seat when operating pressure is applied above the non-wicking diaphragm. When pressure above the diaphragm is relieved, the valve opens wide. The rate of closing or opening can be controlled by modulating the flow into or out of the cover chamber. When a pressure reversal occurs the split stem will immediately allow the disc retainer assembly to check closed **regardless of the position of the diaphragm.**

The Model 100-04 is used on system applications such as remote control, pressure regulation, solenoid control, etc.; wherever a positive check feature is necessary to prevent reverse flow. Its packless construction and simplicity of design minimizes maintenance and assures a long dependable service life.

Principle of Operation

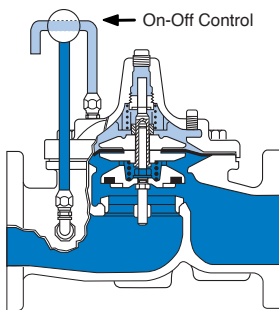

Full Open Operation

When pressure in the cover chamber is relieved to a zone of lower pressure, the line pressure at the valve inlet opens the valve, allowing full flow.

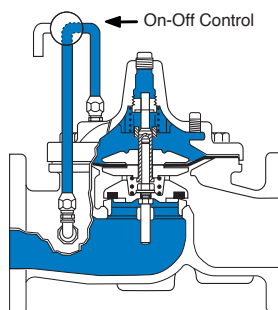

Tight Closing Operation

When pressure from the valve inlet is applied to the cover chamber, the valve closes drip-tight.

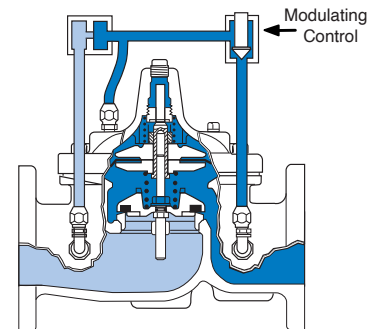

Check Action

When a static condition or pressure reversal occurs, the split stem design allows the valve to instantly check closed. Return flow is prevented regardless of the diaphragm's position.

Note: For optimum operation of built-in check feature, installation with stem vertically up is recommended.

Specifications

Model 100-04

Available Sizes

Pattern	Flanged
Globe	2" - 16" 50 - 400 mm
Angle	3" - 16" 80 - 400 mm

Operating Temp. Range

Fluids
-40° to 180° F -40° to 82° C

Pressure Ratings (Recommended Maximum Pressure - psi)

Valve Body & Cover		Pressure Class			
		Flanged		Threaded	
Grade	Material	ANSI Standards*	150 Class	300 Class	End‡ Details
ASTM A536	Ductile Iron	B16.42	250	400	400
ASTM A216-WCB	Cast Steel	B16.5	285	400	400
UNS 87850	Bronze	B16.24	225	400	400

Note: * ANSI standards are for flange dimensions only.
Flanged valves are available faced but not drilled.
‡ End Details machined to ANSI B2.1 specifications.

Valves for higher pressure are available; consult factory for details

Materials

Component	Standard Material Combinations		
Body & Cover	Ductile Iron	Cast Steel	Bronze
Available Sizes (inches)	2" - 16"	2" - 16"	2" - 16"
Available Sizes (mm)	50 - 400 mm	50 - 400 mm	50 - 400 mm
Disc Retainer & Diaphragm Washer	Cast Iron	Cast Steel	Bronze
Trim: Disc Guide, Seat & Cover Bearing	Bronze is Standard Stainless Steel is optional		
Disc	Buna-N® Rubber		
Diaphragm	Nylon Reinforced Buna-N® Rubber		
Stem, Nut & Spring	Stainless Steel		
For material options not listed, consult factory. Cla-Val manufactures valves in more than 50 different alloys.			

Options

Epoxy Coating - suffix KC

The NSF/ANSI 61 fusion bonded epoxy coating option is for use with cast iron, ductile iron or steel valves. This coating is resistant to various water conditions, certain acids, chemicals, solvents and alkalis. epoxy coatings are applied in accordance with AWWA coating specifications C116-03. Do not use with temperatures above 175° F / 80° C.

Viton® Rubber Parts - suffix KB

Optional diaphragm, disc and o-ring fabricated with Viton® synthetic rubber. Viton® is well suited for use with mineral acids, salt solutions, chlorinated hydrocarbons, and petroleum oils; and is primarily used in high temperature applications up to 250°F/120°C. Do not use with epoxy coating above 175°F/80° C.

For assistance in selecting appropriate valve options or valves manufactured with special design requirements, please contact our Regional Sales Office or Factory.

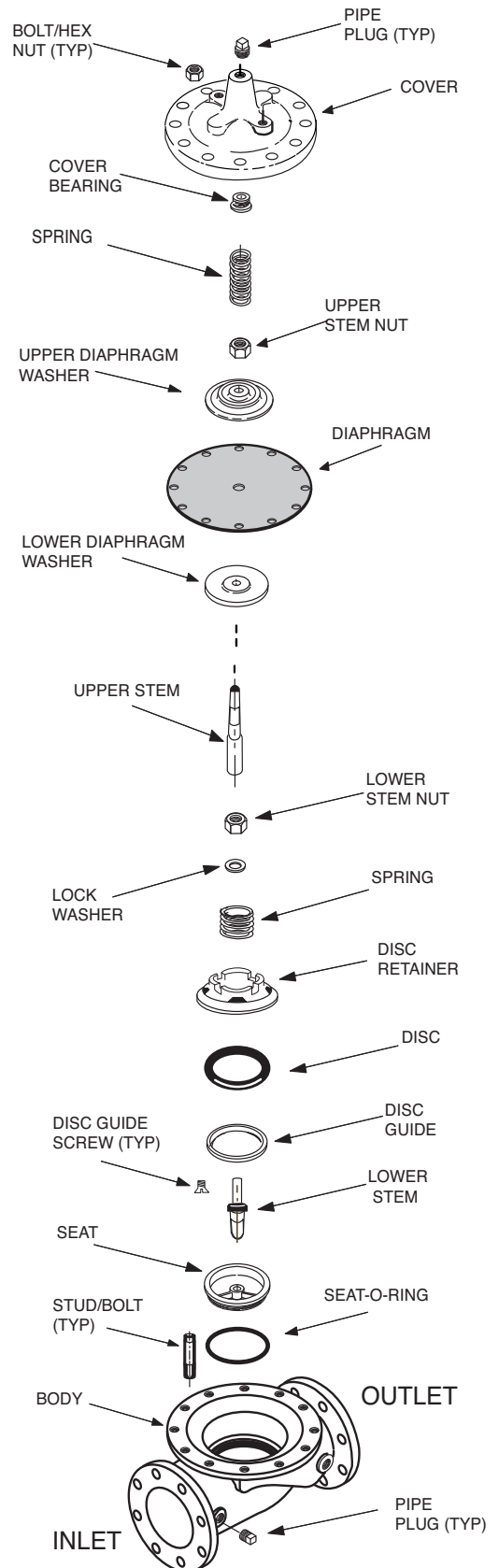

Valve Size		Inches	2	3	4	6	8	10	12	14	16
		mm.	50	80	100	150	200	250	300	350	400
C _V Factor	Globe Pattern	Gal./Min. (gpm.)	54	115	200	440	770	1245	1725	2300	3130
		Litres/Sec. (l/s.)	13	27.6	48	105.6	184.8	299	414	553	752
	Angle Pattern	Gal./Min. (gpm.)	61	139	240	541	990	1575	2500*	3060*	4200*
		Litres/Sec. (l/s.)	14.6	33.4	58	130	238	378	601	735	1009
Equivalent Length of Pipe	Globe Pattern	Feet (ft.)	51	85	116	211	291	347	467	422	503
		Meters (m.)	15.5	25.9	35.3	64.2	88.6	105.8	142.4	128.6	153.6
	Angle Pattern	Feet (ft.)	40	58	80	139	176	217	222*	238*	247*
		Meters (m.)	12.1	17.8	24.5	42.5	53.6	66.1	67.8	72.7	75.2
K Factor	Globe Pattern		5.6	6.0	5.9	6.2	6.1	5.8	6.1	5.0	4.6
	Angle Pattern		4.4	4.1	4.1	4.1	3.7	3.6	2.9	2.8	2.6
Liquid Displaced from Cover Chamber When Valve Opens		Fl. Oz	—	—	—	—	—	—	—	—	—
		U.S. Gal.	0.3	.08	.17	.53	1.26	2.51	4.0	6.5	9.6
		ml	121	303	643	—	—	—	—	—	—
		Litres	—	—	—	2.0	4.8	9.5	15.1	24.6	36.2

*Estimated

C_V Factor

Formulas for computing C_V Factor, Flow (Q) and Pressure Drop (ΔP):

$$C_V = \frac{Q}{\sqrt{\Delta P}} \quad Q = C_V \sqrt{\Delta P} \quad \Delta P = \left(\frac{Q}{C_V}\right)^2$$

K Factor (Resistance Coefficient)

The Value of K is calculated from the formula: $K = \frac{894d^4}{C_V^2}$ (U.S. system units)

Equivalent Length of Pipe

Equivalent lengths of pipe (L) are determined from the formula: $L = \frac{Kd}{12f}$ (U.S. system units)

Fluid Velocity

Fluid velocity can be calculated from the following formula: $V = \frac{.4085 Q}{d^2}$ (U.S. system units)

Where:

C_V = U.S. (gpm) @ 1 psi differential at 60° F water
or

C_V-l/s = (l/s) @ 1 bar (14.5 PSIG) differential at 15° C water

d = inside pipe diameter of Schedule 40 Steel Pipe (inches)

f = friction factor for clean, new Schedule 40 pipe (dimensionless) (from Cameron Hydraulic Data, 18th Edition, P 3-119)

K = Resistance Coefficient (calculated)

L = Equivalent Length of Pipe (feet)

Q = Flow Rate in U.S. (gpm) or (l/s)

V = Fluid Velocity (feet per second) or (meters per second)

ΔP = Pressure Drop in (psi) or (bar)

Model 100-04 Flow Chart (Based on normal flow through a wide open valve)

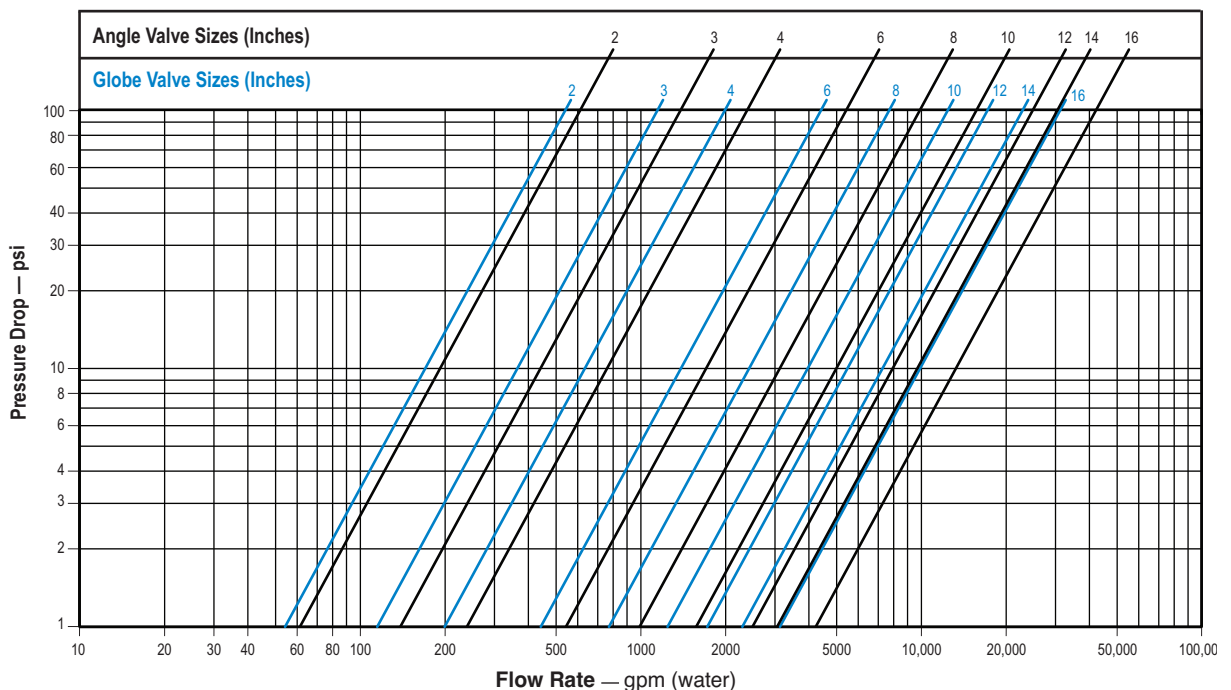

Cla-Val 100-04 Hy-Check Main Valve Dimensions

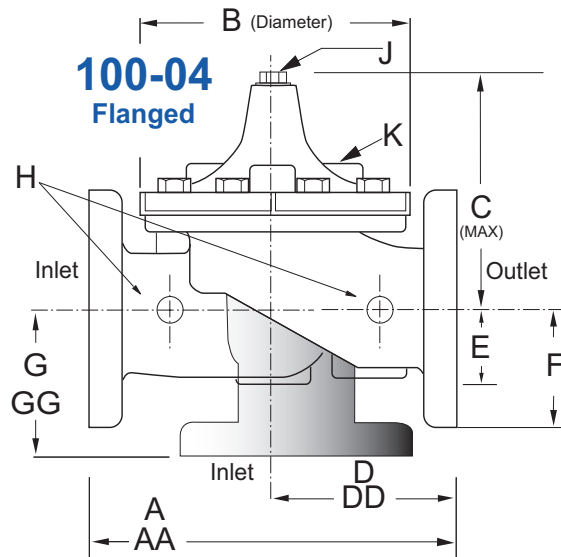

Valve Size (Inches)	2	3	4	6	8	10	12	14	16
A 150 ANSI	9.38	12.00	15.00	20.00	25.38	29.75	34.00	39.00	41.38
AA 300 ANSI	10.00	13.25	15.62	21.00	26.38	31.12	35.50	40.50	43.50
B Diameter	6.62	9.12	11.50	15.75	20.00	23.62	28.00	32.75	35.50
C Maximum	6.50	8.19	10.62	13.38	16.00	17.12	20.88	24.19	25.00
D 150 ANSI	4.75	6.00	7.50	10.00	12.69	14.88	17.00	19.50	20.69
DD 300 ANSI	5.00	6.38	7.81	10.50	13.19	15.56	17.75	20.25	21.75
E	1.50	2.56	3.19	4.31	5.31	9.25	10.75	12.62	15.50
F 150 ANSI	2.50	3.75	4.50	5.50	6.75	8.00	9.50	10.50	11.75
FF 300 ANSI	3.25	4.13	5.00	6.25	7.50	8.75	10.25	11.50	12.75
G 150 ANSI	3.25	4.00	5.00	6.00	8.00	8.62	13.75	14.88	15.69
GG 300 ANSI	3.25	4.38	5.31	6.50	8.50	9.31	14.50	15.62	16.50
H NPT Body Tapping	0.38	0.50	0.75	0.75	1.00	1.00	1.00	1.00	1.00
J NPT Cover Center Plug	0.50	0.50	0.75	0.75	1.00	1.00	1.25	1.50	2.00
K NPT Cover Tapping	0.38	0.50	0.75	0.75	1.00	1.00	1.00	1.00	1.00
Stem Travel	0.60	.080	1.10	1.70	2.30	2.80	3.40	4.00	4.50
Approx. Ship Weight (lbs)	35	70	140	285	500	780	1165	1500	2265

Valve Size (mm)	50	80	100	150	200	250	300	350	400
A 150 ANSI	238	305	381	508	645	756	864	991	1051
AA 300 ANSI	254	337	397	533	670	790	902	1029	1105
B Diameter	168	232	292	400	508	600	711	832	902
C Maximum	165	208	270	340	406	435	530	614	635
D 150 ANSI	121	152	191	254	322	378	432	495	526
DD 300 ANSI	127	162	200	267	335	395	451	514	552
E	38	65	81	109	135	235	273	321	394
F 150 ANSI	76	95	114	140	171	203	241	267	298
FF 300 ANSI	83	105	127	159	191	222	260	292	324
G 150 ANSI	83	102	127	152	203	219	349	378	399
GG 300 ANSI	89	111	135	165	216	236	368	397	419
H NPT Body Tapping	0.38	0.50	0.75	0.75	1.00	1.00	1.00	1.00	1.00
J NPT Cover Center Plug	0.50	0.50	0.75	0.75	1.00	1.00	1.25	1.50	2.00
K NPT Cover Tapping	0.38	0.50	0.75	0.75	1.00	1.00	1.00	1.00	1.00
Stem Travel	15	20	28	43	58	71	86	102	114
Approx. Ship Weight (kgs)	16	32	64	129	227	354	528	726	1027

Service

Cla-Val Control Valves operate with maximum efficiency when mounted in horizontal piping with the main valve cover UP, however, other positions are acceptable. Due to component size and weight of 8 inch and larger valves, installation with cover UP is advisable. We recommend isolation valves be installed on inlet and outlet for maintenance. Adequate space above and around the valve for service personnel should be considered essential. A regular maintenance program should be established based on the specific application data. However, we recommend a thorough inspection be done at least once a year. Consult factory for specific recommendations.



—MODEL— **CRL-60**

Pressure Relief Control

DESCRIPTION

The CRL-60 Pressure Relief Control is a direct acting, spring loaded, diaphragm type relief valve. It may be used as a self-contained valve or as a pilot control for a Cla-Val Main valve. It opens and closes within very close pressure limits.

INSTALLATION

The CRL-60 Pressure Relief Control may be installed in any position.

The control body (1) has one inlet and one outlet port. Body (1) also has smaller side ports; one on inlet, one on outlet, each with pipe plugs (23) installed. These smaller side ports are used for control connections or gauge applications. The body (1) also has one center side port, used as the sensing line port. A flow arrow is marked on the body casting.

OPERATION

The CRL-60 Pressure Relief Control is normally held closed by the force of the compression spring above the diaphragm; control pressure is applied under the diaphragm.

When the controlling pressure exceeds the spring setting, the disc is lifted off its seat, permitting flow through the control.

When controlling pressure drops below spring setting, the spring returns the control to its normally closed position.

ADJUSTMENT PROCEDURE

The CRL-60 Pressure Relief Control can be adjusted to provide a relief setting at any point within the range found on the nameplate.

Pressure adjustment is made by turning the adjustment screw (11) to vary the spring pressure on the diaphragm. Turning the adjustment screw clockwise increases the pressure required to open the valve. Counterclockwise decreases the pressure required to open the valve.

When pressure adjustments are complete the jam nut (10) should be tightened and the protective cap (12) replaced. If there is a problem of tampering, lock wire holes have been provided in cap and cover. Wire the cap to cover and secure with lead seal.

DISASSEMBLY

The CRL-60 Pressure Relief Control does not need to be removed from the line for disassembly. Make sure that pressure shut down is accompanied prior to disassembly. If the CRL-60 is removed from the line for disassembly be sure to use a soft jawed vise to hold body during work.

Refer to Parts List Drawing for Item Numbers.

1. Remove cap (12), loosen jam nut (10) and turn adjusting screw counterclockwise until spring tension is relieved.
2. Remove the eight screws (15) holding the cover (9). Keep the cover and eight screws together and place on a suitable work surface. See NOTE under REASSEMBLY.
3. Remove the cover (9) from body (1). The spring (8) and two spring guides (7).
4. Remove plug (22) from body (1). Using screwdriver, hold stem assembly (4) to remove nut (13).
5. Slide off the belleville washer (14), upper diaphragm washer (18), diaphragm (17) and lower diaphragm washer (19).
6. Remove stem guide (21) from body (1). Remove stem assembly (4). Inspect, replace stem assembly and/or O-rings (5), (6) and (20) if necessary. Use soft jawed pliers or vise to hold stem. The polished surface of stem must not be scored or scratched.
7. The seat (3) need not be removed unless it is damaged. If removal is necessary use proper size socket wrench and turn counterclockwise.

INSPECTION

Inspect all parts for damage, or evidence of cross threading. Check diaphragm for tears. Check stem assembly (4) for abrasions or other damage. Check all metal parts for damage, corrosion or excessive wear.

REPAIR AND REPLACEMENT

Minor nicks and scratches may be polished out using 400 grit wet or dry sandpaper fine emery or crocus cloth. Replace all O-rings and any damaged parts.

When ordering replacement parts, be sure to specify parts list item number and all nameplate data.

REASSEMBLY

In general, reassembly is the reverse of disassembly. However, the following steps should be observed:

1. Lubricate the O-Ring (5) and (6) with a small amount of a good grade of waterproof grease, (Dow Corning 44 medium grade or equal). Use grease sparingly when installing O-ring (20) into guide stem (21).
2. Install stem assembly (4) into guide stem (21). Use a rotating motion with minimum pressure to let stem pass through O-ring. Do Not Cut O-Ring.
3. Install O-ring (6) at top of stem assembly (4). Install guide stem (21) and stem assembly (4) into body (1). Use socket to tighten securely. Place lower diaphragm washer (19) on the stem assembly with the serrated side up. Position diaphragm (17), upper diaphragm washer (18), with serration down, and belleville washer (14) with concave side down.
4. Install nut (13) and tighten securely.
5. Continue reassembly as outlined in disassembly steps 1 through 3.

SYMPTOM	PROBABLE CAUSE	REMEDY
Fails to open.	Controlling pressure too low.	Back off adjusting screw until valve opens.
Fails to open with spring compression removed.	Mechanical obstruction, corrosion, scale build-up on stem.	Disassemble, locate, and remove obstruction, scale.
Leakage from cover vent hole when controlling pressure is applied.	Diaphragm Damage	Disassembly replace damaged diaphragm.
	Loose diaphragm assembly.	Tighten upper diaphragm washer.
Fails to close.	No spring compression.	Re-set pressure adjustment.
Fails to close with spring compressed.	Mechanical obstruction.	Disassemble, locate and remove obstruction.



CRL-60

1/2" & 3/4" PRESSURE RELIEF CONTROL

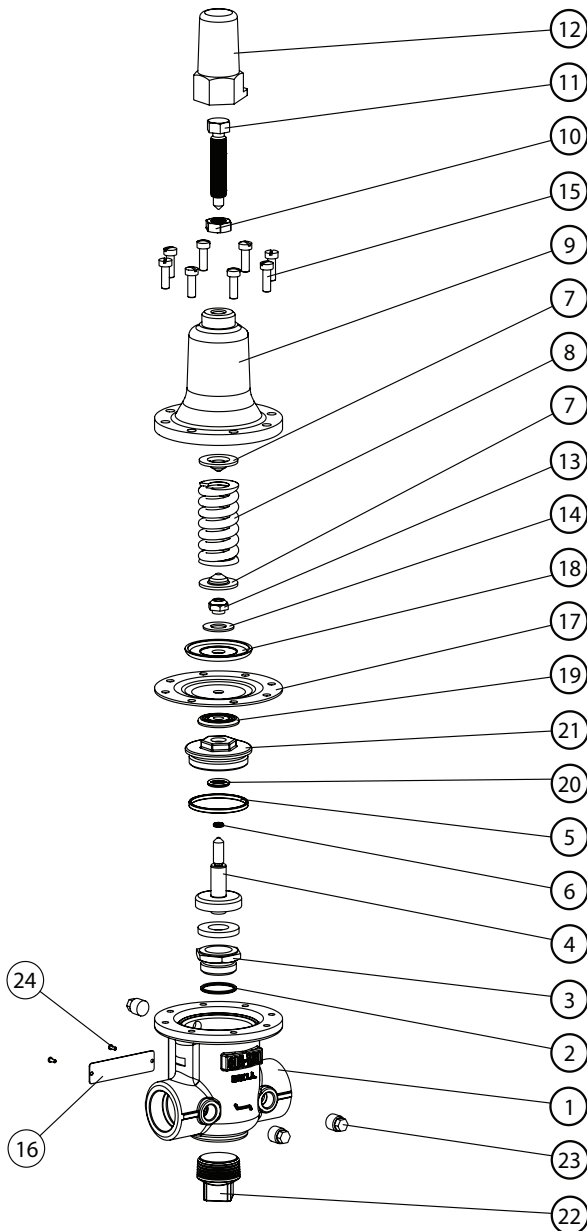

Item	Description	Quantity
------	-------------	----------

1	BODY	1
* 2	O-RING	1
3	SEAT 1/2" & 3/4"	1
* 4	STEM ASSEMBLY	1
* 5	O-RING	1
* 6	O-RING	1
7	Guide Spring	2
8	SPRING	1
9	COVER	1
10	Hexnut .375--16 UNC	1
11	Adjusting Screw	1
12	Cap	1
13	NUT, STEM	1
14	BELLEVILLE WASHER FLAT	1
15	FIL HD SCREW #10--32 UNF	8
16	NAMEPLATE	1
* 17	DIAPHRAGM	1
18	Washer Diaphragm Upper	1
19	DIAPHRAGM WASHER	1
* 20	O-RING	1
21	GUIDE STEM	1
22	3/4" NPT PIPE PLUG	1
23	1/8" NPT PIPE PLUG	3
24	DRIVE SCREW	2

* SUGGESTED REPAIR PARTS REPAIR KIT;
1/2" & 3/4".....P/N 9170033G

Size	Spring	Part Number
1/2"	0 - 75 PSI	20840401A
1/2"	20 - 105 PSI	20840408D
1/2"	20 - 200 PSI	20840402K
1/2"	†100 - 300 PSI	20861201J
3/4"	0 - 75 PSI	20840403J
3/4"	20 - 200 PSI	20840404H
3/4"	†100 - 300 PSI	20861202H
1"	20 - 75 PSI	20944105K
1"	20 - 400 PSI	20944106J
1"	100 - 300 PSI	20944107H
for 250 - 600 PSI, Consult Factory		

†The 100-300 PSI spring requires a larger cover than the other CRL-60 springs.

CRL-60 Spring Range PSI	APPROX. INCREASE FOR EACH CLOCKWISE TURN OF ADJUSTING SCREW
0 to 75	8.5 PSI
20 to 75	6.0 PSI
20 to 105	12.5 PSI
20 to 200	28.0 PSI
40 to 200	18.0 PSI
100 to 300	18.0 PSI

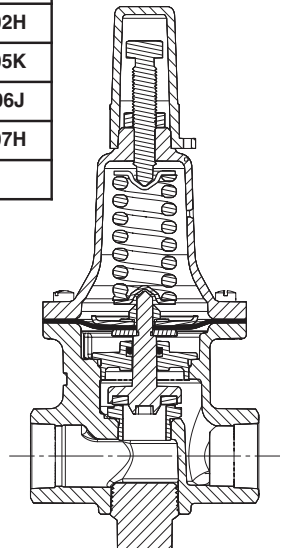

When ordering parts please specify:

1. All Nameplate Data
2. Item Part Number
3. Item Description



Model CRL

PRESSURE RELIEF CONTROL

DESCRIPTION

The CRL Pressure Relief Control is a direct acting, spring loaded, diaphragm type relief valve. It may be used as a self-contained valve or as a pilot control for a Cla-Val Main valve. It opens and closes within very close pressure limits.

OPERATION

The CRL Pressure Relief Control is normally held closed by the force of the compression spring above the diaphragm; control pressure is applied under the diaphragm. When the controlling pressure exceeds the spring setting, the disc is lifted off its seat, permitting flow through the control. When controlling pressure drops below spring setting, the spring returns the control to its normally closed position.

INSTALLATION

The CRL Pressure Relief Control may be installed in any position. The control body (7) has one inlet and one outlet port with a side pipe plug (24) at each port. These plugs are used for control connections or gauge applications. The inlet in the power unit body (6) is the sensing line port. A flow arrow is marked on the body casting.

ADJUSTMENT PROCEDURE

The CRL Pressure Relief Control can be adjusted to provide a relief setting at any point within the range found on the nameplate. Pressure adjustment is made by turning the adjustment screw (9) to vary the spring pressure on the diaphragm. Turning the adjustment screw clockwise increases the pressure required to open the valve. Counterclockwise decreases the pressure required to open the valve. When pressure adjustments are complete the jam nut (10) should be tightened and the protective cap (1) replaced. If there is a problem of tampering, lock wire holes have been provided in cap and cover. Wire the cap to cover and secure with lead seal.

MAINTENANCE

Disassembly

The CRL Pressure Relief Control does not need to be removed from the line for disassembly. Make sure that pressure shut down is accompanied prior to disassembly. If the CRL is removed from the line for disassembly be sure to use a soft jawed vise to hold body during work. Refer to Parts List Drawing for Item Numbers.

1. Remove cap (1), loosen jam nut (10) and turn adjusting screw counterclockwise until spring tension is relieved.

2. Remove the eight screws (4) holding the cover (3) and powerunit body (6). Hold the cover and powerunit together and place on a suitable work surface. See NOTE under REASSEMBLY.

3. Remove the cover (3) from powerunit body (6). The spring (12) and two spring guides (11).

4. Remove nut (13) from stem (19) and slide off the belleville washer (14), the upper diaphragm washer (15) and the diaphragm (16).

5. Pull the stem (19) with the disc retainer assembly (21) through the bottom of powerunit. The lower diaphragm washer (17) will slide off of stem top.

6. Remove jam nut (23) and disc retainer assembly (21) from stem. Use soft jawed pliers or vise to hold stem. The polished surface of stem must not be scored or scratched.

7. The seat (22) need not be removed unless it is damaged. If removal is necessary use proper size socket wrench and turn counterclockwise. Note: Some models have an integral seat in the body (7).

Inspection

Inspect all parts for damage, or evidence of cross threading. Check diaphragm and disc retainer assembly for tears, abrasions or other damage. Check all metal parts for damage, corrosion or excessive wear.

Repair and Replacement

Minor nicks and scratches may be polished out using 400 grit wet or dry sandpaper fine emery or crocus cloth. Replace all O-rings and any damaged parts. When ordering replacement parts, be sure to specify parts list item number and all nameplate data.

Reassembly

In general, reassembly is the reverse of disassembly. However, the following steps should be observed:

1. Lubricate the O-Ring (18) with a small amount of a good grade of waterproof grease, (Dow Corning 44 medium grade or equal). Use grease sparingly and install O-ring in powerunit body (6).

2. Install stem (19) in powerunit body (6). Use a rotating motion with minimum pressure to let stem pass through O-ring. Do Not Cut O-Ring.

3. Install O-ring (5) at top of stem (19). Place lower diaphragm washer (17) on the stem with the serrated side up. Position diaphragm (16), upper diaphragm washer (15), with serration down, and belleville washer (14) with concave side down.

4. Position powerunit body (6) as shown on parts list drawing (top view).

5. Continue reassembly as outlined in disassembly steps 1 through 3.

Note:

Item (4) Screw will have a quantity of 8 for the 0-75 and 20-200psi design and a quantity of 4 for the 100-300psi design. Item (25) Screw is used on the 100-300psi design only. Install item (25), before item (4) for preload of item (12) spring.

Service Suggestions		
Symptom	Possible Cause	Solutions
Fails to open	Controlling pressure too low.	Back off adjusting screw until valve opens.
Fails to open with spring compression removed.	Mechanical obstruction, corrosion, scale build-up on stem.	Disassemble, locate, and remove obstruction, scale.
Leakage from cover vent hole when controlling pressure is applied.	Damaged diaphragm	Disassembly replace damaged diaphragm.
	Loose diaphragm assembly.	Tighten upper diaphragm washer.
Fails to close.	No spring compression.	Re-set pressure adjustment.
Fails to close with spring compressed.	Mechanical obstruction.	Disassemble, locate and remove obstruction.





— MODEL — **X47A**
Ejector



DESCRIPTION

The Cla-Val Model X47A Ejector is a compact, precision fitting, incorporating a primary and a secondary jet, designed to create a low-pressure area at the suction port.

OPERATION

The X47A Ejector is designed for use in a pilot control system on a Cla-Val Main Valve. Pressure is applied to the inlet port (A). As the fluid passes through the center portion of the X47A Ejector, the high velocity entrains particles of fluid from suction port (B), which results in a reduced pressure at this port.

In actual operation, the pressure port (A) is connected to the upstream side of the Main Valve; the discharge port (C) is connected to the Pilot Control; and the suction port (B) is connected to the cover chamber of the Main Valve.

Fluid line pressure enters at the inlet port (A). When the Pilot Control is closed, no flow occurs through the X47A Ejector, and full line pressure is directed into the Main Valve cover chamber, closing the Main Valve tight. As the Pilot Control opens, and flow through the X47A Ejector begins, pressure at the suction port (B) decreases until the Main Valve is permitted to open. Further changes in the flow rate resulting from opening and closing of the Pilot Control produce corresponding changes in the flow through the Main Valve.

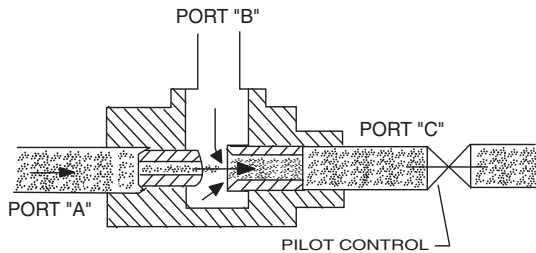

PILOT CONTROL OPEN

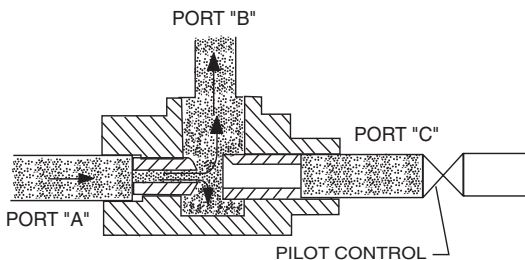

PILOT CONTROL CLOSED

DISASSEMBLY

Do not attempt to remove primary or secondary jets from X47A Ejector housing.

INSPECTION

Inspect port threads for damage or evidence of cross-threading. Check primary and secondary jets for clogging or embedded foreign particles. Check for breaks, cracks, fatigue, and other signs of damage.

CLEANING

After inspection, cleaning of the X47A can begin. Water service usually will produce mineral or lime deposits on metal parts in contact with water. These deposits can be cleaned by dipping the X47A in a 5-percent muriatic acid solution just long enough for deposits to dissolve. This will remove most of the common types of deposits. **Caution: use extreme care when handling acid.** If the deposit is not removed by acid, then a fine grit (400) or dry sandpaper can be used with water. Rinse parts in water before handling. An appropriate solvent can clean parts used in fueling service. Dry with compressed air or a clean, lint-free cloth. Protect from damage and dust until reassembled.

REPLACEMENT

If there is any sign of damage, or if there is the slightest doubt that the X47A Ejector may not afford completely satisfactory operation, replace it. Use Inspection steps as a guide. Neither the primary jet, secondary jet, or bare housing is furnished as a replacement part. Replace X47A Ejector as a complete unit.

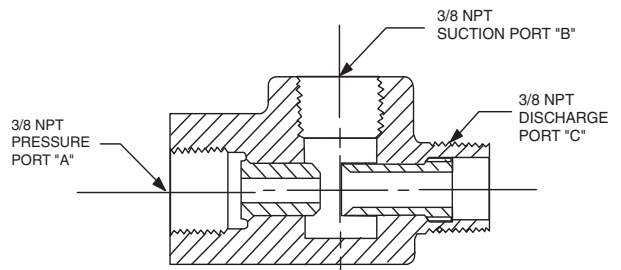

NOTE: OBTAIN AS COMPLETE ASSEMBLY ONLY. SPECIFY NUMBER STAMPED ON SIDE OF EJECTOR WHEN RE-ORDERING.



X47A

3/8" Ejector

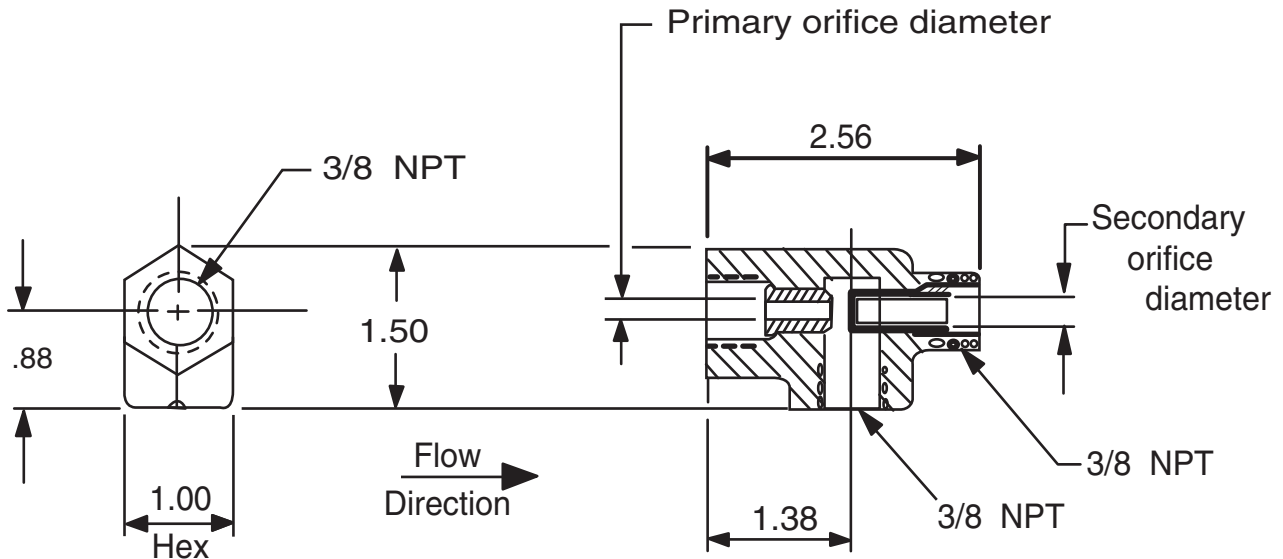

NOTE: Sold as complete assembly. No replacement parts available.

When ordering parts, please specify:

- Number Stamped on Side
- Description (X47A 3/8" Ejector)
- Orifice Dimensions
- Materials

BRONZE HOUSING - 303 S.S. INSERTS

CLA-VAL X47A STK. NO.	ORIFICE DIAMETER	
	PRIMARY	SECONDARY
C4311B	1/16	3/32
C4312K	1/8	3/16
C4089D	3/16	9/32

303 S.S. HOUSING - 303 S.S. INSERTS

CLA-VAL X47A STK. NO.	ORIFICE DIAMETER	
	PRIMARY	SECONDARY
32899H	1/16	3/32
C6168D	3/16	9/32
65274D	5/32	9/32



Model 100-01

3/8" - 1" HYTROL VALVE

PARTS LIST

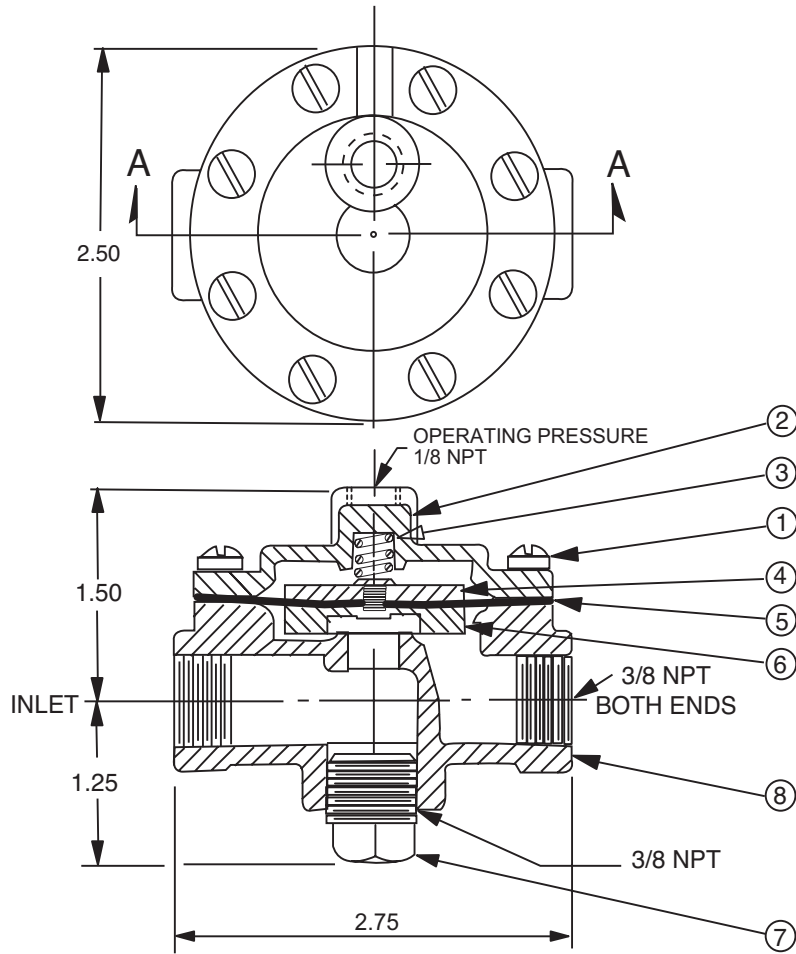

SECTION AA

100-01 3/8" HYTROL VALVE

When Ordering, Please Specify

1. All Nameplate data
2. Item Number
3. Description
4. Material

Item No.	Description
1	Cover Screw (8 Required)
2	Cover
3	Spring
4	Diaphragm Washer
*5	Diaphragm
*6	Disc Retainer Assembly
7	Body Plug (3/8 NPT)
8	Body

* Recommended Spare Parts





Model 100-01 1/2" - 3/4" - 1" HYTROL VALVE

100-01 3/4" & 1/2" Hytrol Valve

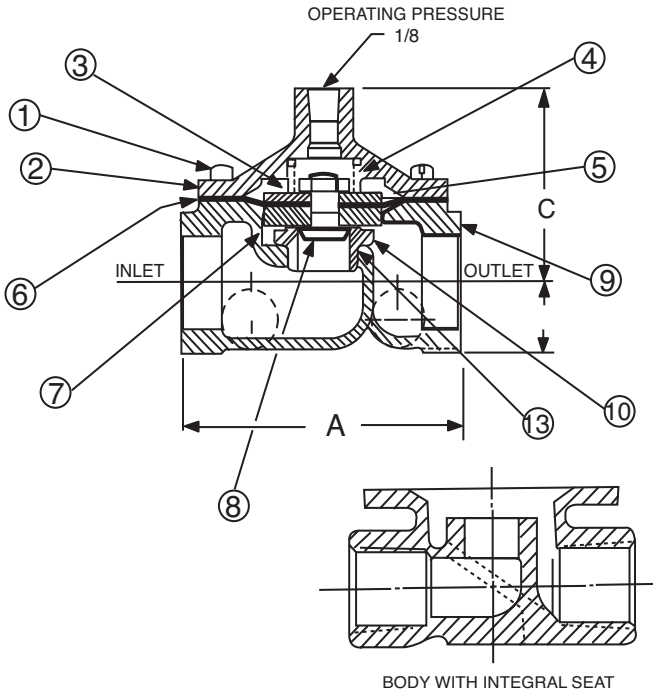

Item No.	Description
1	Cover Screw
2	Cover
3	Spring
4	Stem Nut
5	Diaphragm Washer
*6	Diaphragm
*7	Disc Retainer Assembly
8	Disc Guide & Stem
9	Body
10	Seat
11	Nameplate
12	Body Plug HEX HD
13	O-Ring Seat (for old style body only)

* Recommended Spare Parts

	1/2	3/4
A	3-1/2	3-1/2
C (Maximum)	2-3/8	2-3/8
D	25/32	29/32

100-01 1" Hytrol Valve

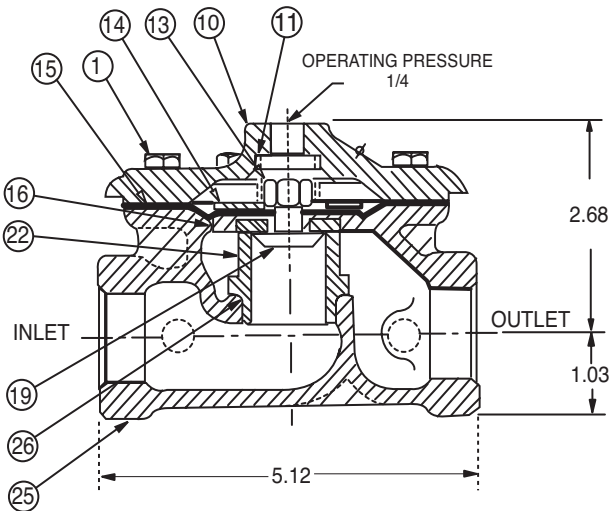

Item No.	Description
1	Cover Screw
2	Nameplate
3	Nameplate Screw
10	Cover
11	Spring
13	Stem Nut
14	Diaphragm Washer
15	Diaphragm
16	Disc Retainer Assembly
19	Disc Guide
22	Seat
24	Body Plug
25	Body
26	O-Ring Seat

* Recommended Spare Parts

When Ordering, Please Specify

1. All Nameplate data
2. Item Number
3. Description
4. Material



INSTALLATION AND MAINTENANCE INSTRUCTIONS

3-WAY SOLENOID VALVES, NORMALLY OPEN NORMALLY CLOSED AND UNIVERSAL CONSTRUCTION

**BULLETIN
8320**

ASCO
FORM NO. V5291R2

DESCRIPTION

Bulletin 8320 is a small 3-way solenoid operated valve with all three pipe connections located in the body. The bodies are of brass or stainless steel construction. Standard valves have General Purpose, Nema Type 1 Solenoid Enclosures. Valves that are equipped with a solenoid enclosure which is designed to meet Nema Type 4-Water tight, Nema Type 7 (C or D) Hazardous Locations - Class I, Group C or D, and Nema Type 9 (E, F or G) Hazardous Locations - Class II, Group E, F or G are shown on separate sheets of Installation and Maintenance Instructions, Form Numbers V-5391 and V-5381.

MANUAL OPERATORS (OPTIONAL)

Valves with suffix "MO" or "MS" in catalog number are provided with a Manual Operator which allows manual operation when desired or during an interruption of electrical power.

OPERATION

Normally Closed: Applies pressure when solenoid is energized; exhausts pressure when solenoid is de-energized

Normally Open: Applies pressure when solenoid is de-energized; exhausts pressure when solenoid is energized.

Universal: For normally closed or normally open operation, selection or diversion of pressure can be applied at port 1 (A), 2 (B), or 3 (C).

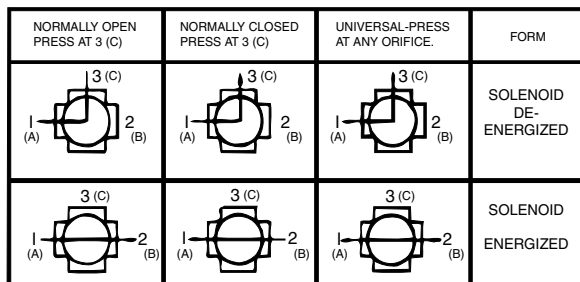

NOTE: Port Markings 1, 2, and 3 correspond directly to A, B and C.

INSTALLATION

Check Nameplate for correct Catalog Number, pressure, voltage and service.

POSITIONING

Valve may be mounted in any position

PIPING

Connect piping to valve according to markings on valve body. Refer to Flow Diagram provided. Apply pipe compound sparingly to male pipe threads only; if applied to valve threads, it may enter valve and cause operational difficulty. Pipe strain should be avoided by proper support and alignment of piping. When tightening pipe, do not use valve as lever.

IMPORTANT: For protection of the solenoid valve, install a strainer or filter suitable for the service involved in the inlet side as close to the valve as possible. Periodic cleaning is required depending on the service conditions.

WIRING

Wiring must comply with local and National Electrical Codes. For valves equipped with an explosion-proof, watertight solenoid enclosure, the electrical fittings must be approved for use in the approved hazardous locations. Housings for all solenoids are made with connections for 1/2 inch conduit. The general purpose enclosure may be rotated to facilitate wiring by removing the retaining cap.

NOTE

Alternating Current (A-C) and Direct Current (D-C) solenoids are built differently. To convert from one to other, it is necessary to change the complete solenoid, including the core assembly.

SOLENOID TEMPERATURE

Standard catalog valves are supplied with coils designed for continuous duty service. When the solenoid is energized for a long period, the solenoid enclosure becomes hot and can be touched with the bare hand for only an instant. This safe operating temperature. Any excessive heating will be indicated by the smoke and odor of burning coil insulation.

MAINTENANCE

WARNING: Turn off electrical power and line pressure to valve before making repairs. It is not necessary to remove valve from pipe line for repairs.

CLEANING

A periodic cleaning of all valves is desirable. The time between cleanings will vary, depending on the media and service conditions. In general, if the voltage to the coils is correct, sluggish valve operation or excessive leakage will indicate that cleaning is required.

IMPROPER OPERATION

1. **Faulty Control Circuit:** Check the electrical system by energizing the solenoid. A metallic click signifies the solenoid is operating. Absence of the click indicate loss of power supply. Check for loose or blown-out fuses, open-circuited or grounded coil, broken lead wires or splice.
2. **Burned-out Coil:** Check for open-circuited coil. Replace coil, if necessary.
3. **Low Voltage:** Check voltage across coil leads. Voltage must be at least 85% of nameplate ratings.
4. **Incorrect Pressure:** Check valve pressure. Pressure to valve must be within the range specified on nameplate.
5. **Excessive Leakage:** Disassemble valve and clean all parts. Replace parts that are worn or damaged with a complete Spare Parts Kit for best results.

COIL REPLACEMENT (REF. FIG. 2)

Turn off electrical power, disconnect coil lead wires and proceed as follows:

1. Remove retaining cap, nameplate and cover.
2. Slip yoke containing coil, sleeves and insulating washers off the solenoid base sub-assembly. Insulating washers are omitted when molded coil is used. In some D.C. Constructions, a single flux plate over the coil replaces yoke, sleeves and insulating washers.
3. Reassemble in reverse order of disassembly.

VALVE DISASSEMBLY AND REASSEMBLY (REF. FIG. 2)

Turn off electrical power supply and de-pressurize valve.

1. Remove retaining cap and slip entire solenoid off solenoid base subassembly or plugnut/core tube sub-assembly.
2. Unscrew bonnet or solenoid base sub-assembly. Remove core assembly, core spring and body gasket.
3. Remove end cap, body gasket, disc spring, disc holder, disc or disc holder assembly.
4. All parts are now accessible for cleaning or replacement. Replace worn or damaged parts with a complete Spare Parts Kit for best results.
5. Reassemble in reverse order of disassembly paying careful attention to exploded view provided.

ORDERING INFORMATION FOR SPARE PARTS KITS

When Ordering Spare Parts Kits or Coils
Specify Valve Catalog Number,
Serial Number and Voltage

Spare Parts Kits and Coils are available for ASCO valves. Parts marked with

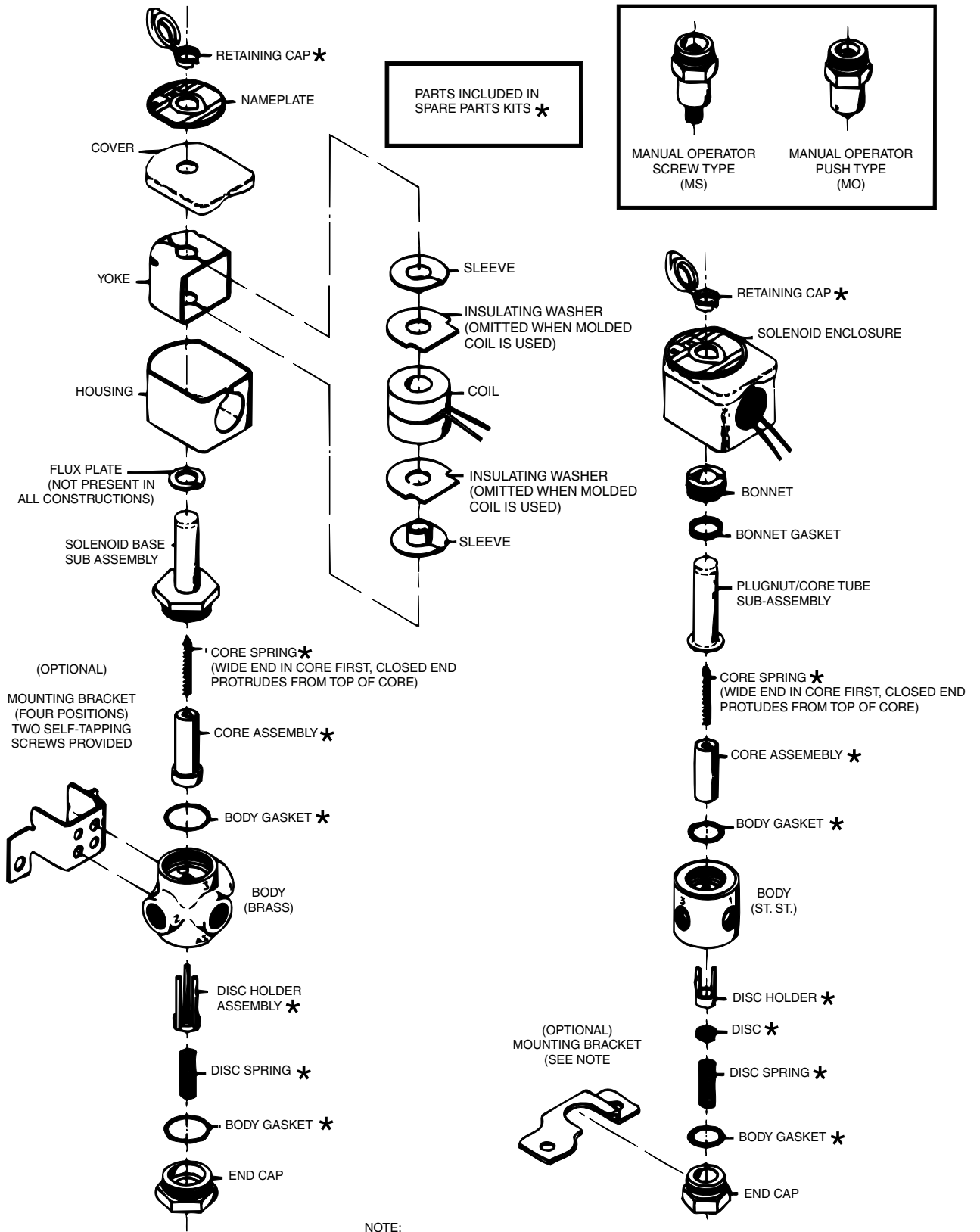

NOTE:
1. FOR MOUNTING, A FLAT SURFACE MUST BE PROVIDED ACROSS THE ENTIRE LENGTH OF THE BRACKET. THE VALVE BODY BECOMES SECURE TO BRACKET, WHEN BRACKET IS TIGHTENED IN TO POSITION. IF THE VALVE HAS A MANUAL OPERATOR, A HOLE MUST BE MADE THROUGH THE MOUNTING SURFACE FOR THE OPERATOR STEM.

INSTALLATION AND MAINTENANCE INSTRUCTIONS

OPEN-FLAME, GENERAL PURPOSE, WATERTIGHT/EXPLOSIONPROOF SOLENOIDS

**BULLETIN
8016G**

ASCO
FORM NO. V6583R5

-SERVICE NOTICE-

ASCO® solenoid valves with design change letter "G" in the catalog number (example: 8210G 1) have an epoxy encapsulated ASCO® Red Hat II. solenoid. This solenoid replaces some of the solenoids with metal enclosures and open-frame constructions. Follow these installation and maintenance instructions if your valve or operator uses this solenoid.

DESCRIPTION

Catalog numbers 8016G1 and 8016G2 are epoxy encapsulated pull-type solenoids. The green solenoid with lead wires and 1/2" conduit connection is designed to meet Enclosure Type 1 -General Purpose, Type 2-Dripproof, Types 3 and 3S-Raintight, and Types 4 and 4X-Watertight. The black solenoid on catalog numbers prefixed "EF" is designed to meet Enclosure Types 3 and 3S-Raintight, Types 4 and 4X-Watertight, Types 6 and 6P-Submersible, type 7 (A, B, C, & D) Explosionproof Class 1, Division 1, Groups A, B, C, & D and Type 9 (E, F, & G)-Dust-Ignitionproof Class 11, Division 1, Groups E, F, & G. The Class 11, Groups F & G Dust Locations designation is not applicable for solenoids or solenoid valves used for steam service or when a class "H" solenoid is used. See Temperature Limitations section for solenoid identification and nameplate/retainer for service. When installed just as a solenoid and not attached to an ASCO valve, the core has a .250-28 UNF-2B tapped hole, 0.38 minimum full thread.

Series 8016G solenoids are available in:

- **Open-Frame Construction**
The green solenoid may be supplied with 1/4" spade, screw, or DIN terminals (Refer to Figure 4).
- **Panel Mounted Construction**
These solenoids are specifically designed to be panel mounted by the customer through a panel having a .062 to .093 maximum wall thickness. (Refer to Figure 3 and section on Installation of Panel Mounted Solenoid).

Optional Features For Type 1—General Purpose Construction Only

- **Junction Box**
This junction box construction meets Enclosure Types 2,3,3S,4, and 4X. Only solenoids with 1/4" spade or screw terminals may have a junction box. The junction box provides a 1/2" conduit connection, grounding and spade or screw terminal Connections within the junction box (See Figure 5).
- **DIN Plug Connector Kit No. K236 - 034**
Use this kit only for solenoids with DIN terminals. The DIN plug connector kit provides a two pole with grounding contact DIN Type 43650 construction (See Figure 6).

OPERATION

When the solenoid is energized, the core is drawn into the solenoid base sub-assembly. **IMPORTANT:** When the solenoid is de-energized, the initial return force for the core, Whether developed by spring, pressure, or weight, must exert a minimum force to overcome residual magnetism created by the solenoid. Minimum return force for AC construction is 11 ounces, and 4 ounces for DC construction.

INSTALLATION

Check nameplate for correct catalog number, service, and wattage. Check front of solenoid for voltage and frequency.

WARNING: To prevent the possibility of electrical shock from the accessibility of live parts, install the open-frame solenoid in an enclosure.

FOR BLACK ENCLOSURE TYPES 7 AND 9 ONLY

CAUTION: To prevent fire or explosion, do not install solenoid and/or valve where ignition temperature is less than 165° C. On valves used for steam service or when a class "H" solenoid is used, do not install in hazardous atmosphere where ignition temperature is less than 180° C. See nameplate/retainer for service. **NOTE:** These solenoids have an internal non-resettable thermal fuse to limit solenoid temperature in the event that extraordinary conditions occur which could cause excessive temperatures. These conditions include high input voltage, a jammed core, excessive ambient temperature or shorted solenoid, etc. This unique feature is a standard feature only in solenoids with black explosionproof/dust-ignitionproof enclosures (types 7&9).

IMPORTANT: To protect the solenoid valve or operator, install a strainer or filter, suitable for the service involved in the inlet side as close to the valve or operator as possible. Clean periodically depending on service condition & See ASCO Series 8600, 8601, and 8602 for strainers.

Temperature Limitations

For maximum valve ambient temperatures, refer to chart. The temperature limitations listed, only indicate maximum application temperatures for field wiring rated at 90°C. Check catalog number prefix and watt rating on nameplate to determine maximum ambient temperature. See valve installation and maintenance instructions for maximum fluid temperature. **NOTE:** For steam service, refer to Wiring section, Junction Box for temperature rating of supply wires.

Temperature Limitations For Series 8016G Solenoids for use Valves Rated at 6.1, 8.1,9.1,10.6 or 11.1 Watts			
Watts Rating	Catalog Number Coil prefix	Class of Insulation	Maximum ambient Temp. °F
6.1, 8.1, 9.1, & 11.1	None, FB, KF, KP, SF, SP, SC, & SD	F	125
6.1, 8.1, 9.1, & 11.1	HB, HT, KB, KH, SS, ST, SU, & ST	H	140
10.6	None, KF, SF, & SC	F	104
10.6	HT, KH, SU, & ST	H	104

Minimum ambient temperature -40° F (-40° C); Positioning

Positioning

This solenoid is designed to perform properly when mounted in any position. However, for optimum life and performance, the solenoid should be mounted vertically and upright to reduce the possibility of foreign matter accumulating in the solenoid base sub-assembly area.

Wiring

Wiring must comply with local codes and the National Electrical Code. All solenoids supplied with lead wires are provided with a grounding wire which is green or green with yellow stripes and a 1/2" conduit connection. To facilitate wiring, the solenoid may be rotated 360°. For the watertight and explosionproof solenoid, electrical fittings must be approved for use in the approved hazardous locations.

Additional Wiring Instructions For Optional Features:

- **Open-Frame solenoid with 1/4" spade terminals**
For solenoids supplied with screw terminal connections use #12-18 AWG stranded copper wire rated at 90°C or greater. Torque terminal block screws to 10 ± 2 in-lbs (1.0 + 1.2 Nm). A tapped hole is provided in the solenoid for grounding, use a #Y10-32 machine screw. Torque grounding screw to 15 -20

in-lbs (1,7 - 2,3 Nm). On solenoids with screw terminals, the socket head screw holding the terminal block to the solenoid is the grounding screw. Torque the screw to 15 - 20 in-lbs (1,7 - 2,3 Nm). with a 5/32" hex key wrench.

• Junction Box

The junction box is used with spade or screw terminal solenoids only and is provided with a grounding screw and a 1/2" conduit connection. Connect #12-18AWG standard copper wire only to the screw terminals. Within the junction box use field wire that is rated 90°C or greater for connections. For steam service use 105°C rated wire up to 50 psi or use 125°C rated wire above 50 psi. After electrical hookup, replace cover gasket, cover, and screws. Tighten screws evenly in a crisscross manner.

• DIN Plug Connector Kit No. KC236-034

1. The open—frame solenoid is provided with DIN terminals to accommodate the DIN plug connector kit.
2. Remove center screw from plug connector. Using a small screwdriver, pry terminal block from connector cover.
3. Use #12-18 AWG stranded copper wire rated at 90°C or greater for connections. Strip wire leads back approximately 1/4" for installation in socket terminals. The use of wire-end sleeves is also recommended for these socket terminals. Maximum length of wire-end sleeves to be approximately 1/4". Tinning of the ends of the lead wires is not recommended.
4. Thread wire through gland nut, gland gasket, washer, and connector cover.

NOTE: Connector cover may be rotated in 90° increments from position shown for alternate positioning of cable entry.

5. Check DIN connector terminal block for electrical markings. Then make electrical hookup to terminal block according to markings on it. Snap terminal block into connector cover and install center screw.
6. Position connector gasket on solenoid and install plug connector. Torque center screw to 5 ± 1 in-lbs ($0,6 \pm 1,1$ Nm).

NOTE: Alternating current (AC) and direct current (DC) solenoids are built differently. To convert from one to the other, it may be necessary to change the complete solenoid including the core and solenoid base sub-assembly, not just the solenoid. Consult ASCO.

Installation of Solenoid

Solenoids may be assembled as a complete unit. Tightening is accomplished by means of a hex flange at the base of the solenoid. The 3/4" bonnet construction (Figure 1) must be disassembled for installation and installed with a special wrench adapter.

Installation of Panel Mounted Solenoid (See Figure 3)

Disassemble solenoid following instruction under Solenoid Replacement then proceed

3/4" Valve Bonnet Construction

1. Install retainer(convex side to solenoid) in 1.312 diameter mounting hole in customer panel.
2. Then position spring washer over plugnut/core tube sub-assembly.
3. Install plugnut/core tube sub-assembly through retainer in customer panel. Then replace solenoid, nameplate/retainer and red cap.

15/16" Valve Bonnet Construction

1. Install solenoid base sub-assembly through 0.69 diameter mounting hole in customer panel.
2. Position spring washer on opposite side of panel over solenoid base sub-assembly then replace.

Solenoid Temperature

Standard solenoids are designed for continuous duty service. When the solenoid is energized for a long period, the solenoid becomes hot and can be touched by hand only for an instant. This is a safe operating temperature.

MAINTENANCE

WARNING: To prevent the possibility of personal injury or property damage, turn off electrical power, depressurize solenoid operator and/or valve, and vent fluid to a safe area before servicing.

Cleaning

All solenoid operators and valves should be cleaned periodically. The time between cleaning will vary depending on medium and service conditions. In general, if the voltage to the solenoid is correct, sluggish valve operation, excessive noise or leakage will indicate that cleaning is required. Clean strainer or filter when cleaning the valve,

Preventive Maintenance

- Keep the medium flowing through the solenoid operator or valve as free from dirt and foreign material as possible.
- While in service, the solenoid operator or valve should be operated at least once a month to insure proper opening and closing.
- Depending on the medium and service conditions, periodic inspection of internal valve parts for damage or excessive wear is recommended. Thoroughly clean all parts. Replace any worn or damaged parts.

Causes of Improper Operation

- **Faulty Control Circuit:** Check the electrical system by energizing the solenoid. A metallic click signifies that the solenoid is operating. Absence of the click indicates loss of power supply. Check for loose or blown fuses, open-circuited or grounded solenoid, broken lead wires or splice connections.

- **Burned-Out Solenoid:** Check for open-circuited solenoid. Replace if necessary. Check supply voltage; it must be the same as specified on nameplate/retainer and marked on the solenoid. Check ambient temperature and check that the core is not jammed.

- **Low Voltage:** Check voltage across the solenoid leads. Voltage must be at least 85% of rated voltage.

Solenoid Replacement

1. On solenoids with lead wires disconnect conduit, coil leads, and grounding wire.

NOTE: Any optional parts attached to the old solenoid must be reinstalled on the new solenoid.

2. Disassemble solenoids with optional features as follows:

• Spade or Screw Terminals

Remove terminal connections, grounding screw, grounding wire, and terminal block (screw terminal type only).

NOTE: For screw terminals, the socket head screw holding the terminal block serves as a grounding screw.

• Junction Box

Remove conduit and socket head screw (use 5/32" hex key wrench) from center of junction box. Disconnect junction box from solenoid.

• DIN Plug Connector

Remove center screw from DIN plug connector. Disconnect DIN plug connector from adapter. Remove socket head screw (use 5/32" hex key wrench), DIN terminal adapter, and gasket from solenoid.

3. Snap off red cap from top of solenoid base sub-assembly.
4. Push down on solenoid. Then using a suitable screwdriver, insert blade in slot provided between solenoid and nameplate/retainer. Pry up slightly and push to remove. Then remove solenoid from solenoid base sub-assembly.
5. Reassemble using exploded views for parts identification and placement

Disassembly and Reassembly of Solenoids

1. Remove solenoid, see Solenoid Replacement.
2. Remove finger washer or spring washer from solenoid base sub-assembly.
3. Unscrew solenoid base sub-assembly.

NOTE: Some solenoid constructions have a plugnut/core tube sub-assembly, bonnet gasket and bonnet in place of the solenoid base sub-assembly. To remove bonnet use special wrench adapter supplied in ASCO Rebuild Kit. For wrench adapter only, order ASCO Wrench Kit No.K218 - 948.

4. The core is now accessible for cleaning or replacement.
5. If the solenoid is part of a valve, refer to basic valve installation and maintenance instructions for further disassembly.
6. Reassemble using exploded views for identification and placement of parts.

ORDERING INFORMATION FOR ASCO SOLENOIDS

When Ordering Solenoids for ASCO Solenoid Operators or Valves, order the number stamped on the solenoid. Also specify voltage and frequency.

Torque Chart

Part Name	Torque Value in inch-Pounds	Torque Value in Newton-Meters
solenoid base sub-assembly	175 ± 25	19.8 ± 2.8
valve bonnet (3/4" bonnet constructions)	90 ± 10	10.2 ± 1.1
bonnet screw (3/8" or 1/2" NPT pipe size)	25	2.8
bonnet screw (3/4" NPT pipe size)	40	4.5

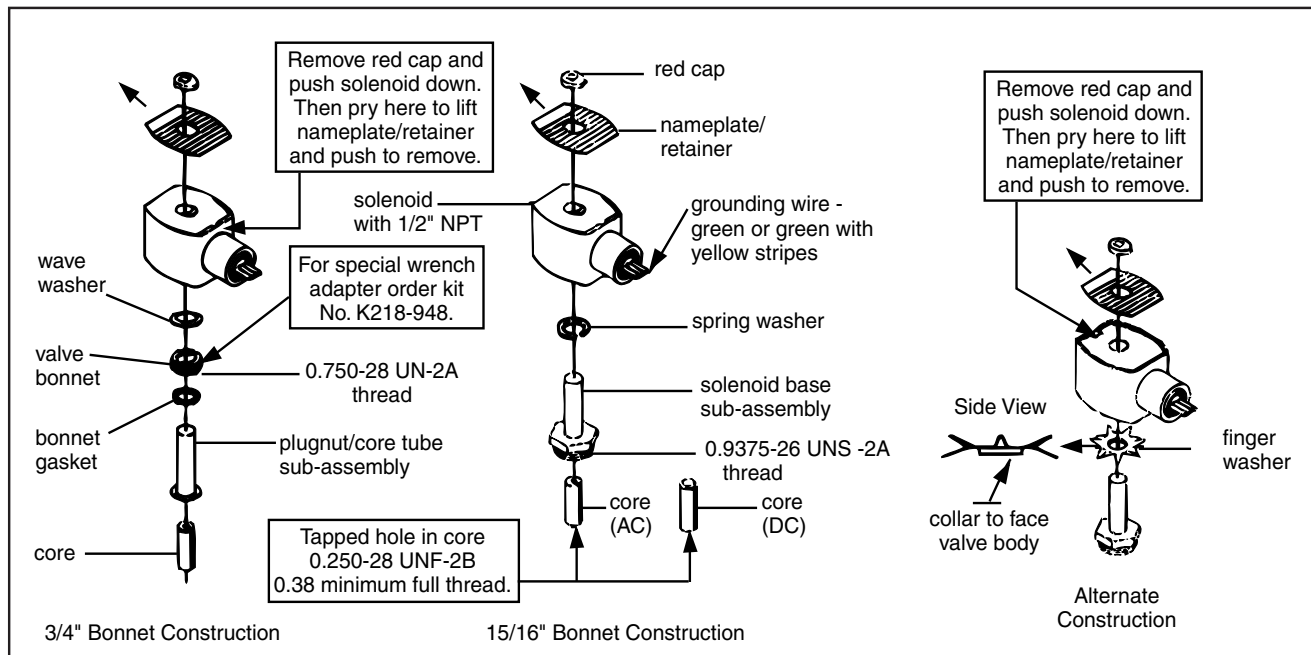

Figure 1. Series 8016G solenoids

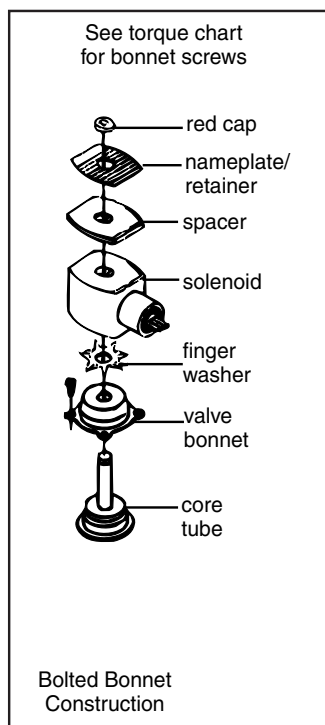

Figure 2. Series 8016G solenoid

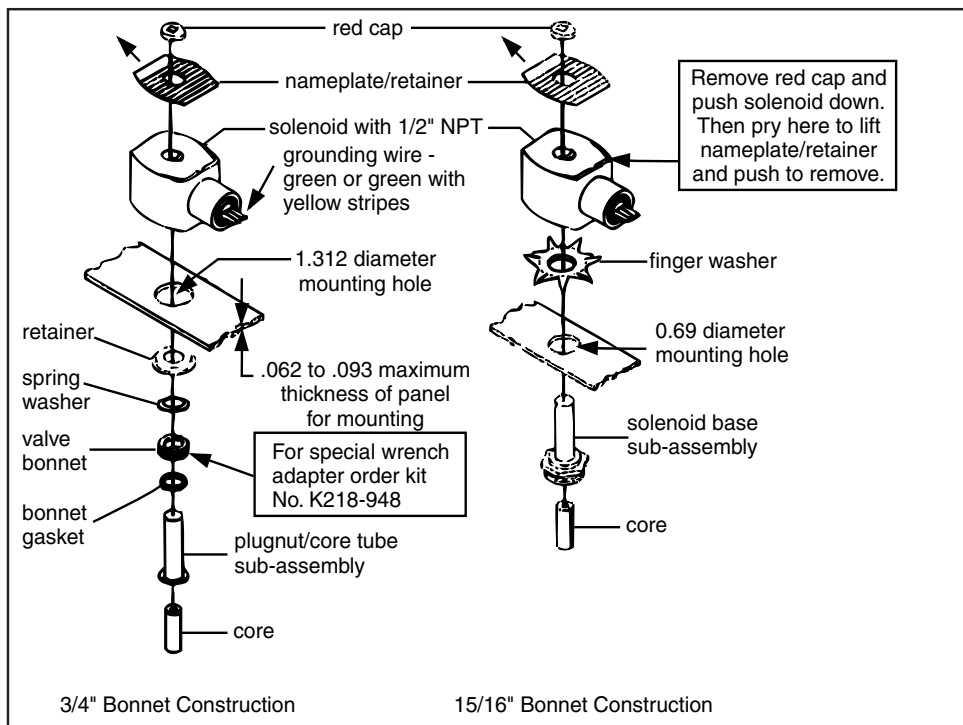

Figure 3. Series 8016G panel mounted solenoids

Torque Chart

Part Name	Torque Value in inch-Pounds	Torque Value in Newton-Meters
terminal block screws	10 ± 2	1,1 ± 0,2
socket head screw	15 - 20	1,7 - 2,3
center screw	5 ± 1	0,6 ± 0,1

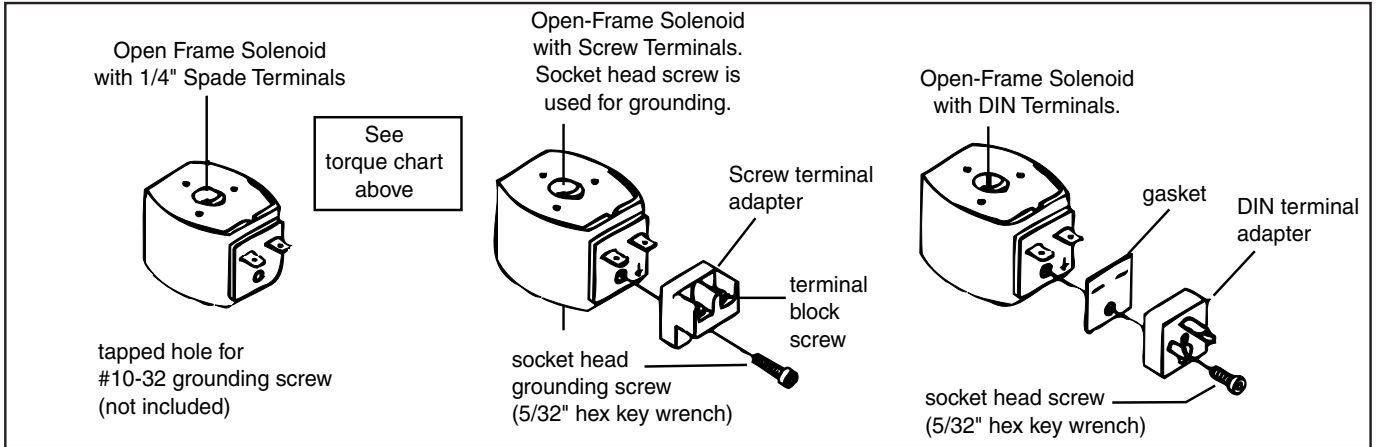

Figure 4. Open - frame solenoids

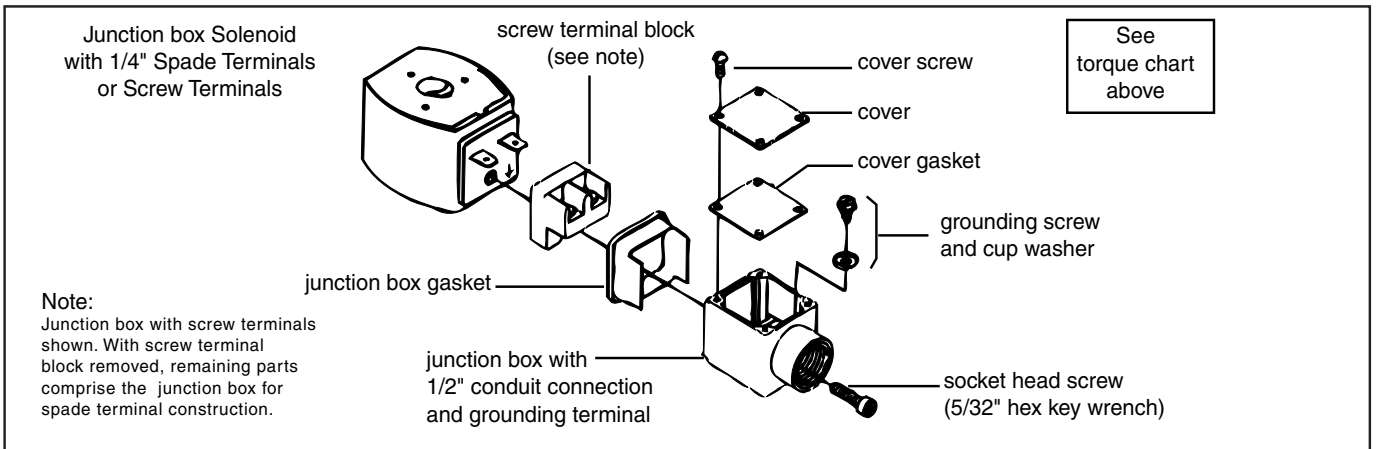
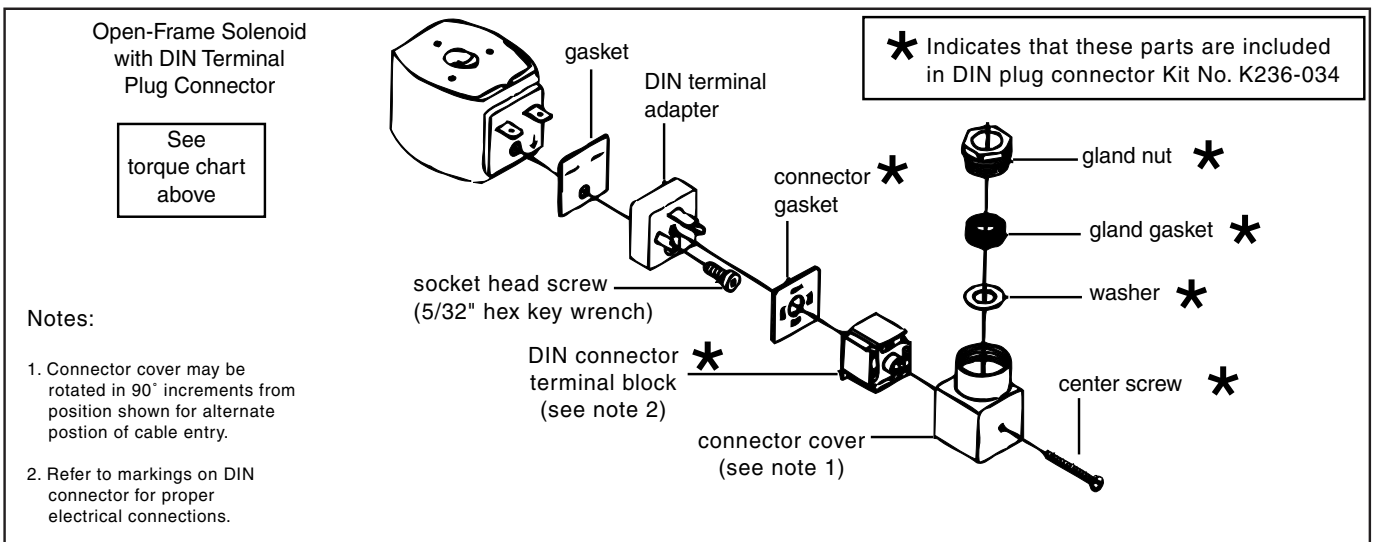

Figure 5. Open - frame solenoids





— MODELS — **X105L**
X105L2

Limit Switch Assemblies

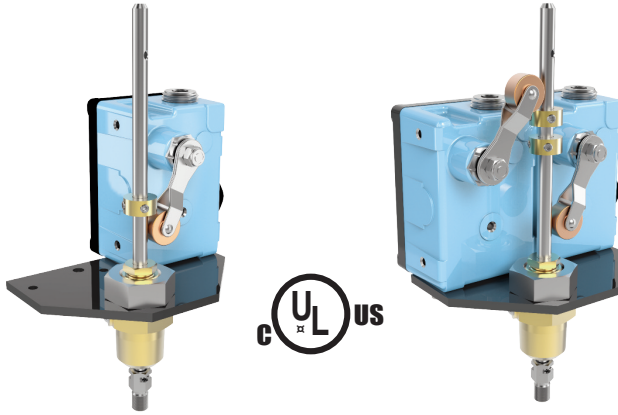

- **UL/ULC Listed**
- **Positive Action**
- **Rugged and Dependable**
- **Weather Proof or Explosion Proof**
- **Easy To Adjust**

The Cla-Val Model X105L/X105L2 Limit Switch Assembly is a rugged, dependable and positive acting switch assembly actuated by the opening or closing of a Cla-Val control valve on which it is mounted. The single pole, double throw micro switch can be connected either to open or to close an electrical circuit when actuated. By loosening the allen screw on the actuating collar and raising or lowering the collar on the stem, the X105L is easily adjusted to signal that the valve has fully reached the desired position (open or closed).

Installation

Single Pole Double Throw Switch

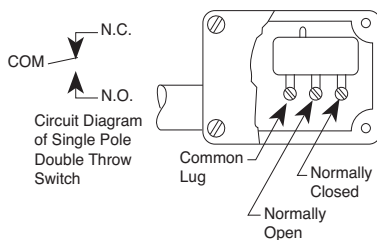

Double Pole Double Throw Switch

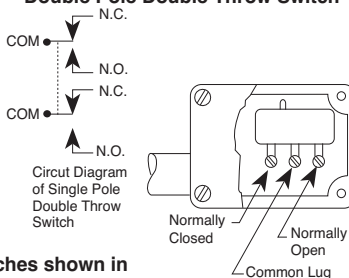

Switches shown in unactivated position.

1. Remove plug in top of valve cover.
2. Screw actuating stem into main valve stem.
3. Slip adapter down over stem and screw into place on valve cover.
4. Attach micro switch housing and bracket to adapter with jam nut.
5. Bring electrical supply circuit into unit through the 1/2" tapping in micro switch housing.
6. Adjust switch collars. (Set collar to trip switch after valve is positioned fully open or fully closed)

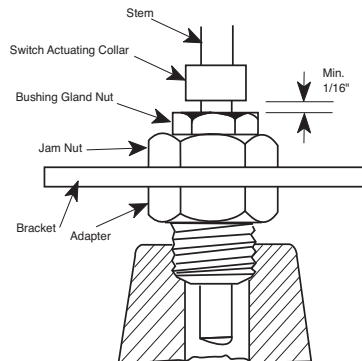

Actuating Collar Adjustment Minimum Setting

When adjusting actuating collar for proper switch action, a clearance of at least 1/16" (1/8" for 48" valve) must be provided between the collar and the bushing gland nut when valve is in the fully closed position.

Purchase Specifications

The assembly shall be bracket-mounted to exterior of an adapter attached to the center of the main valve cover. A stainless steel actuating stem with a swivel adapter shall be fastened directly to the main valve stem and move vertically through an adapter and gland with two O-ring seals as the valve moves. An adjustable collar located on the actuating stem shall actuate the sensor arm of a switch when valve has fully reached the open or closed (specify) position. The rotary-type position sensor arm shall actuate SPDT or DPDT type (specify) micro-switches mounted inside protective housing either weather-tight or explosion-proof NEMA rated (specify).

Provisions shall be made for bleeding air from valve cover through a small bleed screw and washer located on one wrench flat of adapter. All assemblies shall be capable of accommodating up to three switches. Standard materials in contact with operating fluid are brass, stainless steel, Monel and Buna-N.

A conduit hub opening in the switch enclosure shall be provided for attaching protective weatherproof conduit for the electrical switch wires (wiring and conduit supplied by others). A sealing plug shall be provided to protect conduit opening during shipping or storage.

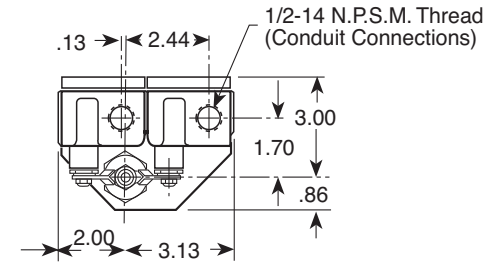

Fig. 1
Valve Size
1 1/4" Thru 8"
X105L2W
X105L2X

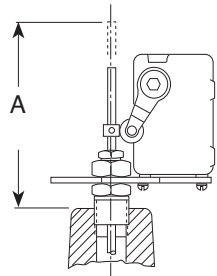

Fig. 2
Valve Size
1 1/4" Thru 14"
X105LCW
X105LCX

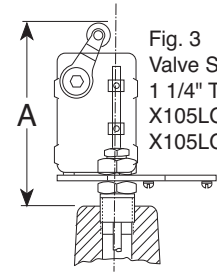

Fig. 3
Valve Size
1 1/4" Thru 8"
X105LOW
X105LOX

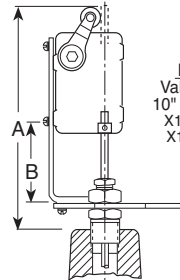

Fig. 4
Valve Size
10" Thru 14"
X105LOW
X105LOX

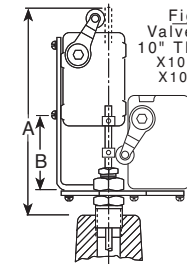
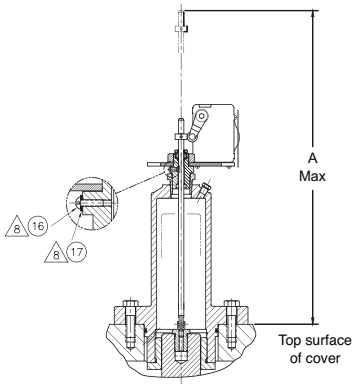
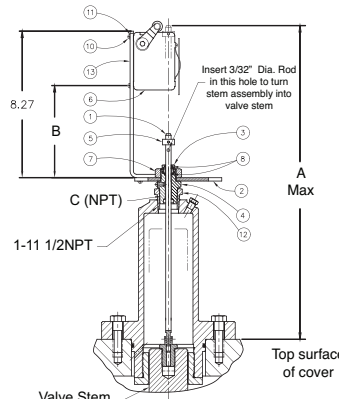

Fig. 5
Valve Size
10" Thru 14"
X105L2W
X105L2X



20" & 24" Size
X105LCW & X105LCX



20" & 24" Size
X105LOW

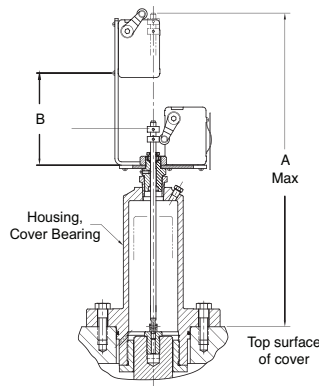

16" Thru 48" Size
X105L2W

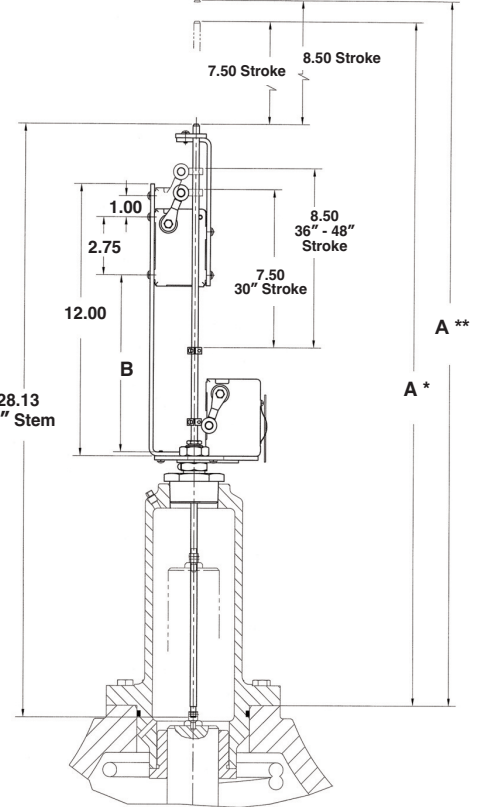

A* - 30" • A** - 36", 42" & 48" Size

X105 Series Dimensions (In Inches)

BasicValve 100-01	1 1/4	1 1/2	2	2 1/2	3	4	6	8	10	12	14	16	18	20	24	30	36*	42*	48*
Dimension "A"	10.19	10.19	7.16	7.16	7.34	7.00	6.69	6.91	9.88	9.59	9.16	10.78	10.78	18.23	19.10	35.07	36.07	36.07	36.07
Dimension "B"							1.69	1.69	2.44	2.94	2.94	2.94	2.94	4.32	5.19	8.40	8.40	8.40	8.40
C (NPT)	1/4	1/4	1/2	1/2	1/2	3/4	3/4	1	1	1 1/4	1 1/2	2	2	3/4	3/4	2	2	2	2
BasicValve 100-20					3	4	6	8	10	12	14	16	18	20	24	30	36*	42*	48*
Dimension "A"					7.16	7.34	7.00	6.69	6.91	9.88	9.59	9.59	10.78	10.78	10.78	11.30	35.07	36.07	36.07
Dimension "B"								1.69	1.69	2.44	2.94	2.94	2.94	2.94	2.94	5.19	8.40	8.40	8.40
C (NPT)					1/2	1/2	3/4	3/4	1	1	1 1/4	1 1/4	2	2	2	1	2	2	2



X105L

Limit Switch Assembly

Parts list shown is for sizes 16" and smaller.
Please consult factory for parts on sizes 18",
20", 24", 30", 36", 42" and 48".

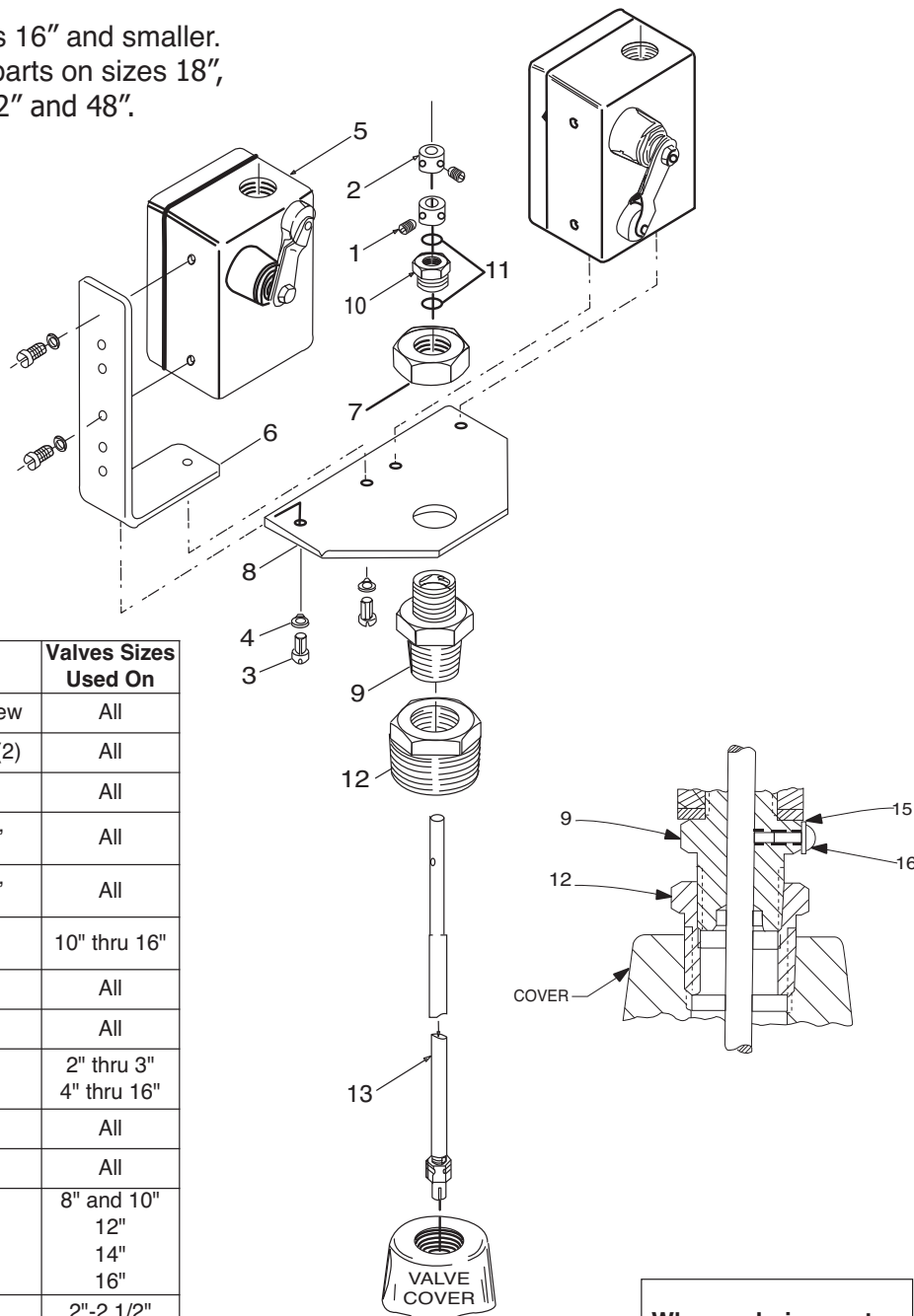

Item	Part Number	Description	Valves Sizes Used On
1-2	20441701E	Collar W/Set Screw	All
3	67578-21B	Screw, Machine (2)	All
4	67584-23F	Washer, Lock (2)	All
5	34637K	Switch Assembly, Weather Proof	All
	34633J	Switch Assembly, Explosion Proof	All
6	64310G	Bracket Switch Mounting	10" thru 16"
7	67815-06J	Nut, Jam	All
8	63674G	Plate, Mounting	All
9	2838201J	Adapter	2" thru 3"
	2838202G	Adapter	4" thru 16"
10	63398C	Bushing, Gland	All
11	00951E	O-Ring (2)	All
12	6764417K	Bushing	8" and 10"
	6764418H	Bushing	12"
	6764419F	Bushing	14"
	6764491J	Bell Reducer	16"
13	8970101F	Stem, Actuating	2"-2 1/2"
	8970102D	Stem, Actuating	3"-4"
	8970103B	Stem, Actuating	6"-8"
	8970104K	Stem, Actuating	10"-12"-14"
	8970105G	Stem, Actuating	16"
15	6551201H	Fiber Washer	All
16	6824421K	Screw 8-32 x 3/8	All

When ordering parts, please specify:

- Item Number
- Description
- Part Number

Typical Applications

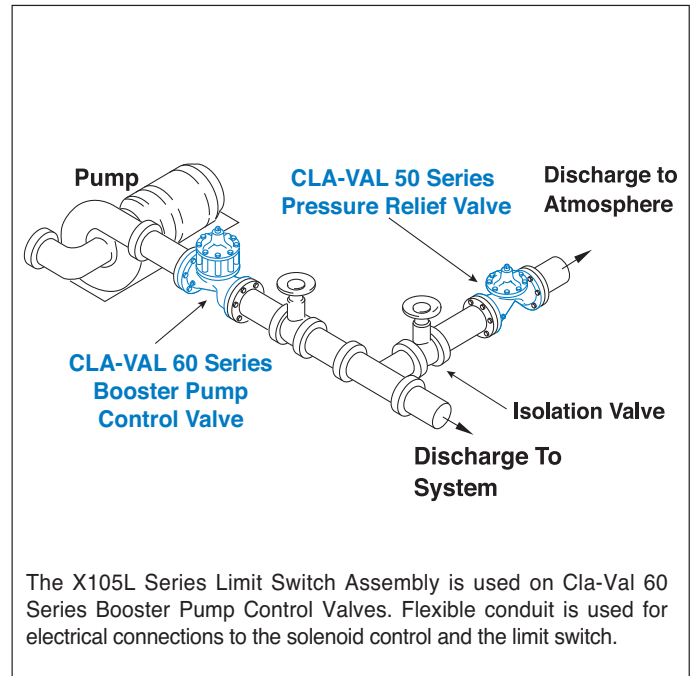
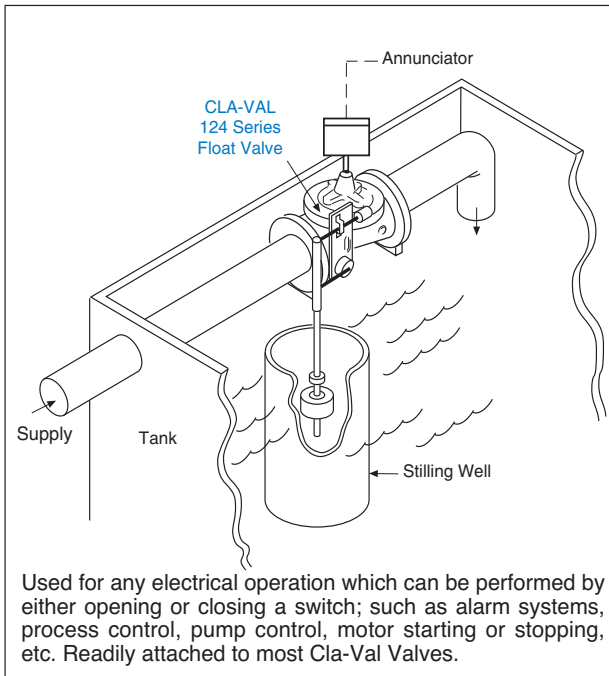

Specifications

Materials: Aluminum switch housing
Steel bracket and brass adapter
Stainless steel stem

Electrical: 1/2" Conduit connection

Switch Type: SPDT UL, File No. E12252,
CSA Certified, File No. LR57325
Weather proof
NEMA 1,3,4, and13

Switch Rating: UL/CSA rating: L96
15 amp. 125, 250, or 480 volts AC
1/2 amp. 125 volts DC
1/4 amp. 250 volts DC

Switch Options: DPDT switches available on request
UL/CSA Rating: L59, 10 amps

Explosion proof micro switches are
NEMA 1,7, and 9
UL Listed, File No. E14274 and CSA
Certified, File No. LR57324: Class I,
Group C and D and Class II, Group
E, F and G.

When Ordering, Please Specify

1. Valve Size and Basic Valve Model Number
2. Catalog Number from Table Below
3. All Valve Name Plate Data
4. Select Single or Double Pole Switch
5. Explosion Proof or Weather Proof Type Enclosure
6. Amperes and Voltage, AC or DC
7. Actuating Position (Valve Open or Closed)

CATALOG NO.	ACTUATION POSITION	SWITCH ENCLOSURE
X105LCW	Valve Closed	Weather Proof
X105LCX	Valve Closed	Explosion Proof
X105LOW	Valve Open	Weather Proof
X105LOX	Valve Open	Explosion Proof
X105L2W	Dual	Weather Proof
X105L2X	Dual	Explosion Proof



CLA-VAL

1701 Placentia Avenue • Costa Mesa, CA 92627

800-942-6326 • Fax: 949-548-5441 • Web Site: cla-val.com • E-mail: info@cla-val.com

CLA-VAL CANADA

4687 Christie Drive
Beamsville, Ontario
Canada L0R 1B4
Phone: 905-563-4963
E-mail sales@cla-val.ca

CLA-VAL EUROPE

Chemin des Mésanges 1
CH-1032 Romanel/
Lausanne, Switzerland
Phone: 41-21-643-15-55
E-mail: cla-val@cla-val.ch

CLA-VAL UK

Dainton House, Goods Station Road
Tunbridge Wells
Kent TN1 2 DH England
Phone: 44-1892-514-400
E-mail: info@cla-val.co.uk

CLA-VAL FRANCE

Porte du Grand Lyon 1
ZAC du Champ du Pérignon
France - 01700 Neyron
Phone: 33-4-72-25-92-93
E-mail: cla-val@cla-val.fr

CLA-VAL PACIFIC

45 Kennaway Road
Woolston, Christchurch, 8023
New Zealand
Phone: 64-39644860
www.cla-valpacific.com
E-mail: info@cla-valpacific.com



Model X105L LIMIT SWITCH ASSEMBLY

PARTS LIST

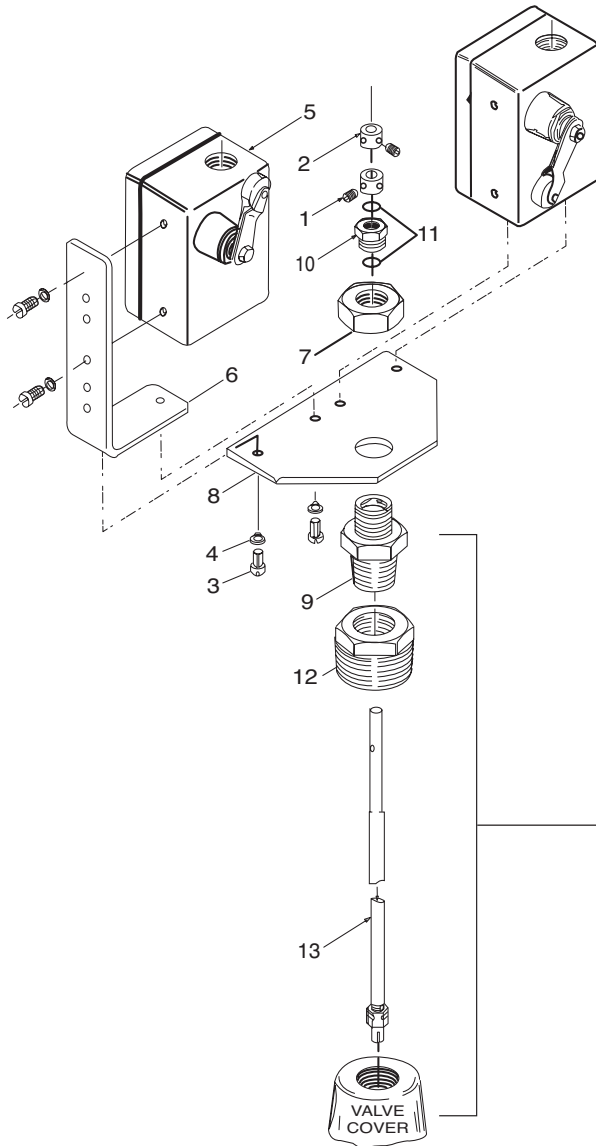

Item No.	Description	Valve Sizes Used On
1-2	Collar with Set Screw	All
3	Screw, Machine (2)	All
4	Washer, Lock (2)	All
5	Switch Assembly, Weather Proof Switch Assembly, Explosion Proof	All
6	Bracket, Switch Mounting	10" - 16"
7	Nut, Jam	All
8	Plate, Mounting	All
9	Adapter Assembly (incl: 15 & 16) Adapter Assembly (incl: 15 & 16)	2" - 3" 4" - 16"
10	Bushing, Gland	All
11	O-Ring (2)	All
12	Bushing, Bell Reducer	8" - 10", 12", 14", & 16"
13	Stem, Actuating	2" - 2-1/2", 3", 4", 6", 7", 8", & 10" - 16"
15	Fiber Washer	All
16	Screw 8-32 x 3/8	All

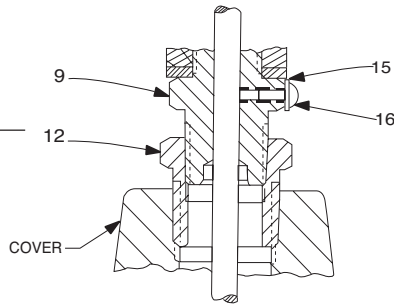

When Ordering, Please Specify

1. All Nameplate data
2. Item Number
3. Description
4. Material



AK	07-10-08	BB	ADDED PN'S 67783-62B (NED 62200)
AK	08-14-08	BC	ADDED PN'S 67783-63K (NED 62218)
PC	10-1-2008	BD	ADDED PN 67783-64H (NED 62446)
CAD REVISION RECORD - DO NOT REVISE MANUALLY		BY	DATE
LTR	DESCRIPTION		
A-AY	SEE REVISION FILE		
BA	ADDED PN'S 67783-59H, 67783-60F & 67783-61D (ECO 20434)	AK	03-14-06

 CLA-VAL CO. NEWPORT BEACH, CALIFORNIA	CATALOG NO.	DRAWING NO.	REV
		67783	BD
TYPE OF VALVE AND MAIN FEATURES		DESIGN	
<p style="text-align: center; font-size: 24pt;">CK2 COCK/BALL VALVE</p>		DRAWN	MGR 4-02-80
		CHK'D	KD 4-03-80
		APV'D	CH 4-07-80

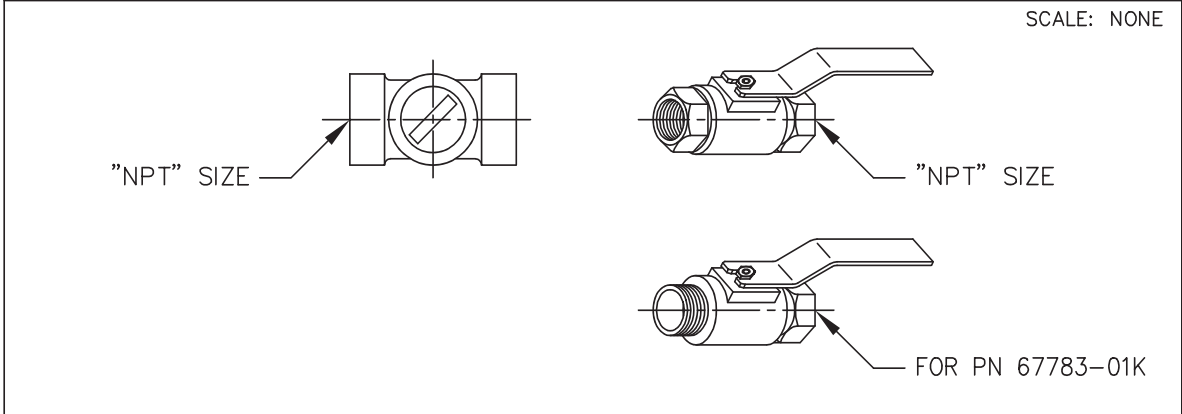

CLA-VAL PART NO. AND MATERIAL								
BRONZE WITH HANDLE	STEEL WITH HANDLE	IRON WITH HANDLE	316 SST WITH HANDLE	316 SST W/ LOCKING HANDLE	BRONZE WITH HANDLE	MONEL WITH HANDLE	MONEL W/ LOCKING HANDLE	SIZE "NPT"
67783-01K*	-09C	-17F	-25J SUPSD BY-26G		-41F SUPSD BY-01K			1/8"
-02H	-10A	-18D	-26G	-51E SUPSD BY-26G -52C	-42D SUPSD BY-02H	-55F		1/4"
-03F * -59H***	-11J	-19B	-27E	-46E SUPSD BY-27E -53A	-45G -57B**	-48A SUPSD BY-49J	-63K	3/8"
-04D -60F***	-12G	-20K	-28C	-54J	-43B SUPSD BY-04D	-49J	-62B	1/2"
-05A -61D***	-13E	-21H	-29A	-64H	-44K SUPSD BY-05A	-56D		3/4"
-06J	-14C	-22F	-30J			-58K		1"
-07G	-15K	-23D	-31G					1 1/4"
-08E	-16H	-24B	-32E					1 1/2"
-50G			-47C					2"

- * SEE ENGINEERING APPROVED VENDORS TABLE (SHEET 2 OF 2).
- ** HAMMOND VALVE 8501 ONLY.
- *** WILKINS CK2 (SEE SHEET 2 OF 2)

"THIS DRAWING IS THE PROPERTY OF CLA-VAL CO. AND SAME AND COPIES MADE THEREOF, IF ANY, SHALL BE RETURNED TO IT UPON DEMAND. DELIVERY AND DISCLOSURE HEREOF ARE SOLELY UPON CONDITION THAT THE SAME SHALL NOT BE USED, COPIED OR REPRODUCED, NOR SHALL THE SUBJECT HEREOF BE DISCLOSED IN ANY MANNER TO ANYONE FOR ANY PURPOSE, EXCEPT AS HEREIN AUTHORIZED, WITHOUT PRIOR WRITTEN APPROVAL OF CLA-VAL CO. THIS DRAWING IS SUBMITTED CONFIDENTIALLY AND MAY NOT BE USED IN THE MANUFACTURE OF ANY MATERIAL OR PRODUCT OTHER THAN SUCH MATERIALS AND PRODUCTS FURNISHED TO CLA-VAL CO. WHETHER OR NOT THE EQUIPMENT OR INFORMATION SHOWN HEREON IS PATENTED OR OTHERWISE PROTECTED, FULL TITLE AND COPYRIGHTS, IF ANY, IN AND TO THIS DRAWING AND/OR INFORMATION DELIVERED OR SUBMITTED ARE FULLY RESERVED CLA-VAL CO."



Model CV FLOW CONTROL

DESCRIPTION

The CV Control is an adjustable restriction which acts as a needle valve when flow is in the direction of the stem. When flow is in the reverse direction, the port area opens fully to allow unrestricted flow. When installed in the control system of a Cla-Val automatic valve, it can be arranged to function as either an opening or closing speed control.

OPERATION

The CV Flow Control permits full flow from port A to B, and restricted flow in the reverse direction. Flow from port A to B lifts the disc from seat, permitting full flow. Flow in the reverse direction seats the disc, causing fluid to pass through the clearance between the stem and the disc. This clearance can be increased, thereby increasing the restricted flow, by screwing the stem out, or counter-clockwise. Turning the stem in, or clockwise reduces the clearance between the stem and the disc, thereby reducing the restricted flow.

INSTALLATION

Install the CV Flow Control as shown in the valve schematic. All connections must be tight to prevent leakage.

DISASSEMBLY

Follow the sequence of the item numbers assigned to the parts in the cross sectional illustration for recommended order of disassembly.

Use a scribe, or similar sharp-pointed tool to remove O-ring from the stem.

INSPECTION

Inspect all threads for damage or evidence of cross-threading. Check mating surface of seat and valve disc for excessive scoring or embedded foreign particles. Check spring for visible distortion, cracks and breaks. Inspect all parts for damage, corrosion and cleanliness.

CLEANING

After disassembly and inspection, cleaning of the parts can begin. Water service usually will produce mineral or lime deposits on metal parts in contact with water. These deposits can be cleaned by dipping the parts in a 5-percent muriatic acid solution just long enough for deposits to dissolve. This will remove most of the common types of deposits. **CAUTION: Use extreme care when handling acid.** If the deposit is not removed by acid, then a fine grit (400) wet or dry sandpaper can be used with water. Rinse parts in water before handling. An appropriate solvent can clean parts used in fueling service. Dry with compressed air or a clean, lint-free cloth. Protect from damage and dust until reassembled.

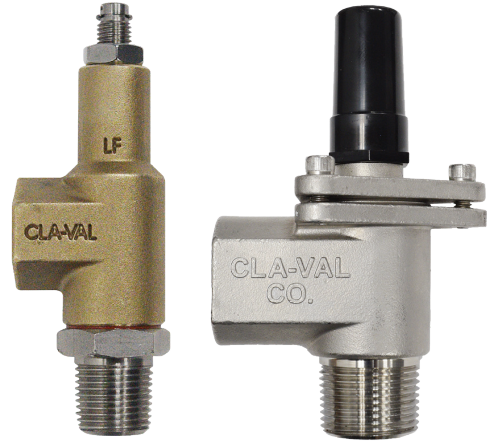

REPAIR AND REPLACEMENT

Minor nicks and scratches may be polished out using a fine grade of emery or crocus cloth; replace parts if scratches cannot be removed.

Replace O-ring packing and gasket each time CV Flow Control is overhauled.

Replace all parts which are defective. Replace any parts which create the slightest doubt that they will not afford completely satisfactory operation. Use Inspection steps as a guide.

REASSEMBLY

Reassembly is the reverse of disassembly; no special tools are required.

TEST PROCEDURE

No testing of the flow Control is required prior to reassembly to the pilot control system on Cla-Val Main Valve.





3/8" CV Flow Control

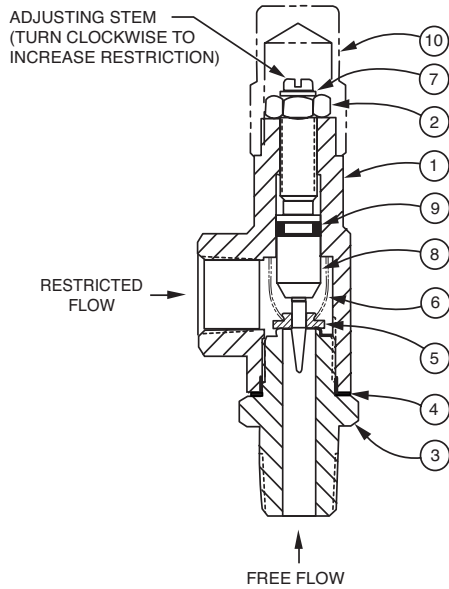

Item No.	Description	QTY
1	Housing	1
2	Nut, Jam	1
3	Seat	1
4	Gasket	1
5	Disc	1
6	Spring	1
7	Ring, Retaining	1
8	Stem	1
9	O-Ring	1
10	Cap (SS only)	1

1/2", 3/4", and 1" CV Flow Control

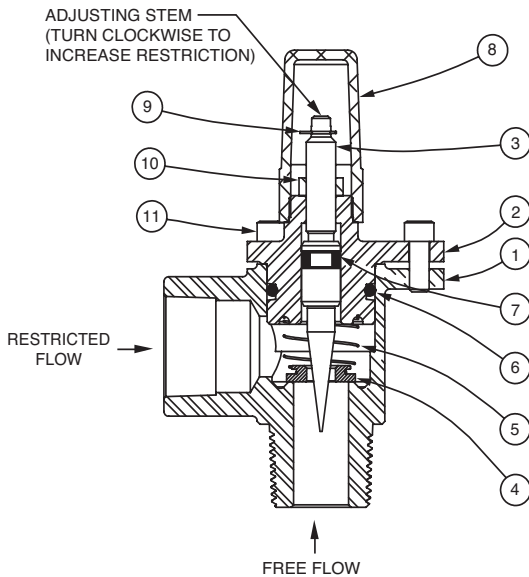

Item No.	Description	QTY
1	Body	1
2	Cover	1
3	Stem	1
4	Disc	1
5	Spring	1
6	O-Ring	1
7	O-Ring	1
8	Cap	1
9	Ring, Retaining	1
10	Nut, Jam	1
11	Socket Head Cap Screw	3

When Ordering, Please Specify

1. All Nameplate/Stamped data
2. Item Number
3. Description
4. Material





Model CV FLOW CONTROL



- Corrosion Resistant
- Easy Adjustments
- Automatic Operation
- No Lubrication
- Operates In Any Position
- Easy Maintenance

The CV Control is an adjustable restriction which acts as a needle valve when flow is in the direction of the stem. When flow is in the reverse direction, the port area opens fully to allow unrestricted flow. When installed in the control system of a Cla-Val automatic valve, it can be arranged to function as either an opening or closing speed control.

Specifications

Size

3/8", 1/2", 3/4", & 1"

End Detail

One connection male &
One connection female

Pressure Rating

400 psi Max.

Temperature Range

250°F Max.

Materials

Housing:
Bronze ASTM B61: 3/8" only
Stainless Steel 316: 3/8", 1/2",
3/4", & 1"

Trim: Stainless Steel

Other Materials available:
All Stainless Steel
Bronze & Monel

Principle of Operation

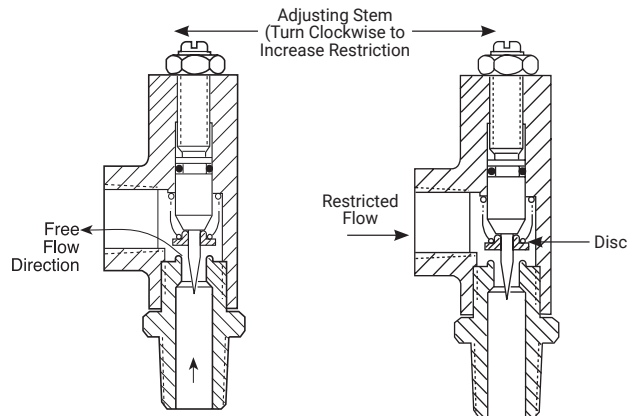

Free Flow, is against the direction of the needle. The disc is forced off its seat by line pressure allowing full capacity flow through the control

Restricted Flow, is in the direction of the needle. This disc is forced against its seat by line pressure. Flow is metered through the control by the fine taper of the needle and the small openings in the disc.

Dimensions (In Inches)

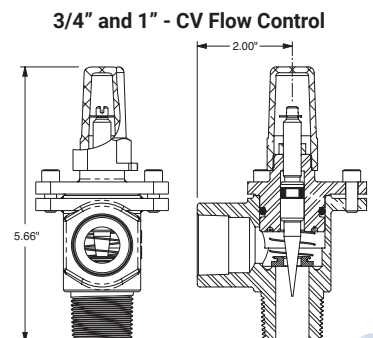
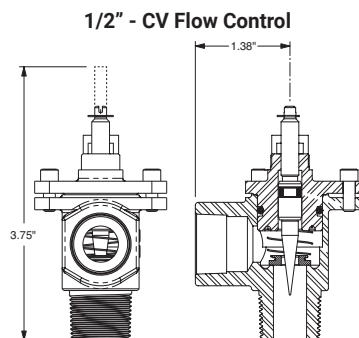
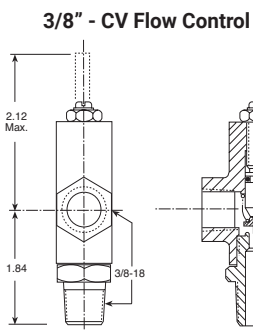



— MODEL — **CDC-1**
Check Valve
 Sizes 3/8", 1/2", 3/4" and 1"

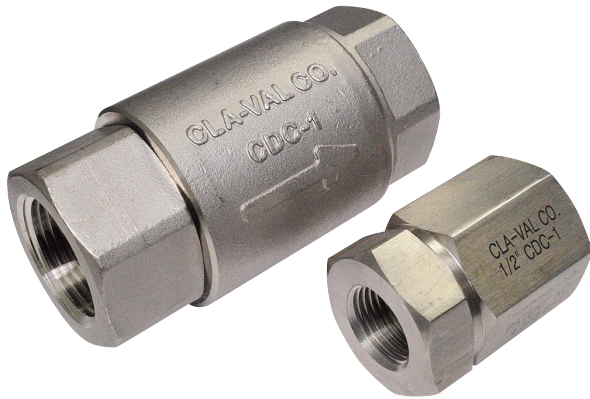

- Meets Low Lead Requirements
- Patented Seal Design Allows for Drip Tight Shut-off at Low DP
- No Spring Required due to Patented Seal Design
- Delrin® Disc with Flow Profile Designed to Minimize Head Loss
- Delrin® Disc Resists Corrosion and/or Mineral Build-up
- Drip Tight Seating at both Low and High Operating Pressures
- Temperature Range: 10°F to 210°F
- EPR, NBR and Fluorocarbon Seal Options

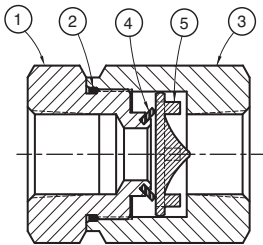

CDC-1 - 3/8" and 1/2"		
Item	Description	Quantity
1	Retainer, Seal	1
*2	O-Ring	1
3	Retainer, Valve	1
*4	Seal, Valve Ring	1
*5	Plate, Valve	1

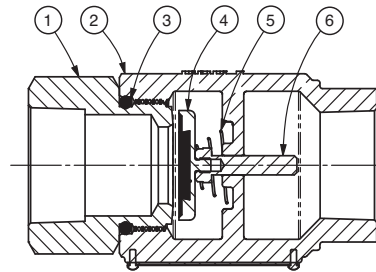

CDC-1 - 3/4" and 1"		
Item	Description	Quantity
1	Seat, Valve	1
2	Body, Valve	1
*3	O-Ring	1
*4	Disc Retainer Assembly	1
*5	Spring	1
*6	Stem, Valve	1

* Included in Repair Kit

Dimensions

Size (NPT)	A	B	C
3/8"	2.06	1.06	0.38 (3/8) - 18.0 NPT
1/2"	2.12	1.38	0.50 (1/2) - 14.0 NPT
3/4"	4.06	2.26	0.75 (3/4) - 14.0 NPT
1"	4.06	2.19	1.00 (1) - 11.5 NPT

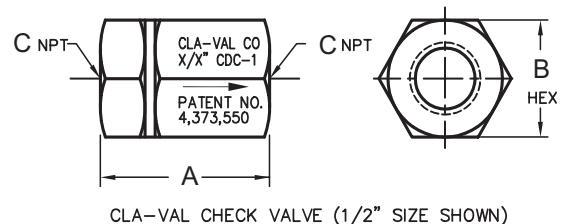



Model X46

PRESSURE REDUCING CONTROL

- Self Scrubbing Cleaning Action
- Straight Type or Angle Type

The Cla-Val Model X46 Strainer is designed to prevent passage of foreign particles larger than 0.015". It is especially effective against such contaminant as algae, mud, scale, wood pulp, moss, and root fibers. There is a model for every Cla-Val valve.

The X46 Flow Clean strainer operates on a velocity principle utilizing the circular "air foil" section to make it self cleaning. Impingement of particles is on the "leading edge" only. The low pressure area on the downstream side of the screen prevents foreign particles from clogging the screen. There is also a scouring action, due to eddy currents, which keeps most of the screen area clean.

INSTALLATION

The strainer is designed for use in conjunction with a Cla-Val Main Valve, but can be installed in any piping system where there is a moving fluid stream to keep it clean. When it is used with the Cla-Val Valve, it is threaded into the upstream body port provided for it on the side of the valve. It projects through the side of the Main Valve into the flow stream. All liquid shunted to the pilot control system and to the cover chamber of the Main Valve passes through the Model X46 Flow Clean Strainer.

INSPECTION

Inspect internal and external threads for damage or evidence of cross-threading. Check inner and outer screens for clogging, embedded foreign particles, breaks, cracks, corrosion, fatigue, and other signs of damage.

DISASSEMBLY

Do not attempt to remove the screens from the strainer housing.

CLEANING

After inspection, cleaning of the Model X46 can begin. Water service usually will produce mineral or lime deposits on metal parts in contact with water. These deposits can be cleaned by dipping Model X46 in a 5-percent muriatic acid solution just long enough for deposit to dissolve. This will remove most of the common types of deposits.

CAUTION: use extreme care when handling acid. If the deposit is not removed by acid, then a fine grit (400) wet or dry sandpaper can be used with water. Rinse parts in water before handling. An appropriate solvent can clean parts used in fueling service. Dry with compressed air or a clean, lint-free cloth.

Protect from damage and dust until reassembled.

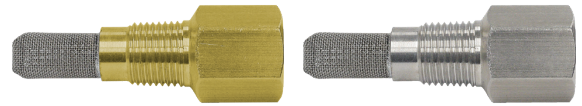

Model X46A Straight

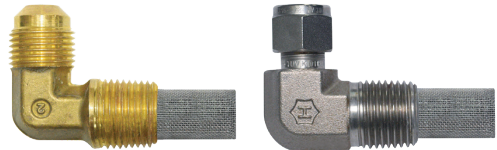

Model X46B Angle

REPLACEMENT

If there is any sign of damage, or if there is the slightest doubt that the Model X46 Flow Clean Strainer may not afford completely satisfactory operation, replace it. Use Inspection steps as a guide. Neither inner screen, outer screen, nor housing is furnished as a replacement part. Replace Model X46 Flow Clean Strainer as a complete unit.

When ordering replacement Flow-Clean Strainers, it is important to determine pipe size of the tapped hole into which the strainer will be inserted (refer to column A or F), and the size of the external connection (refer to column B or G).



Dimensions (in Inches)

X46 Straight Type A (In Inches)						
A (NPT)	C (NPT)	D	E	F	G	I
1/8	1/8	1-3/4	3/4	1/2	1/2	1/4
1/4	1/4	2-1/4	1	3/4	3/4	3/8
3/8	3/8	2-1/2	1	7/8	7/8	1/2
3/8	1/2	2-1/2	1-1/4	1/2	7/8	3/4
1/2	1/2	3	1-1/4	1	1-1/8	3/4
3/8	3/4	3-3/8	2	1/2	1	7/8
3/4	3/4	4	2	1	1-1/2	7/8
3/8	1	4-1/4	2-3/4	1/2	1-3/8	7/8
1	1	4-1/2	2-3/4	1-1/4	1-3/4	7/8
1/2	1	4-1/4	2-3/4	1/2	1-3/8	7/8

X46 Angle Type B (In Inches)					
B (NPT)	C (SAE)	D	E	H	I
1/8	1/4	1-3/8	5/8	7/8	1/4
1/4	1/4	1-3/4	3/4	1	3/8
3/8	1/4	2	7/8	1	1/2
3/8	3/8	1-7/8	7/8	1	1/2
1/2	3/8	2-3/8	1	1-1/4	5/8

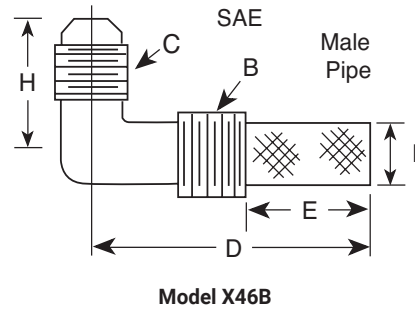
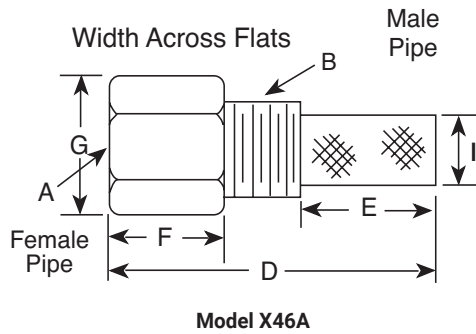

When Ordering, Please Specify

1. Catalog number X46
2. Straight or Angel Type
3. Size inserted into and size connection
4. Materials





X43 Strainer

ITEM	DESCRIPTION	MATERIAL
1	Pipe Plug	Stainless Steel
2	Strainer Plug	Stainless Steel
3	Gasket	Fiber
4	Screen	Stainless Steel
5	Body	Stainless Steel

No parts available. Replacement assembly only.

Standard 60 mesh pilot system strainer for fluid service.

Size	Stock Number
3/8 x 3/8	8850604D

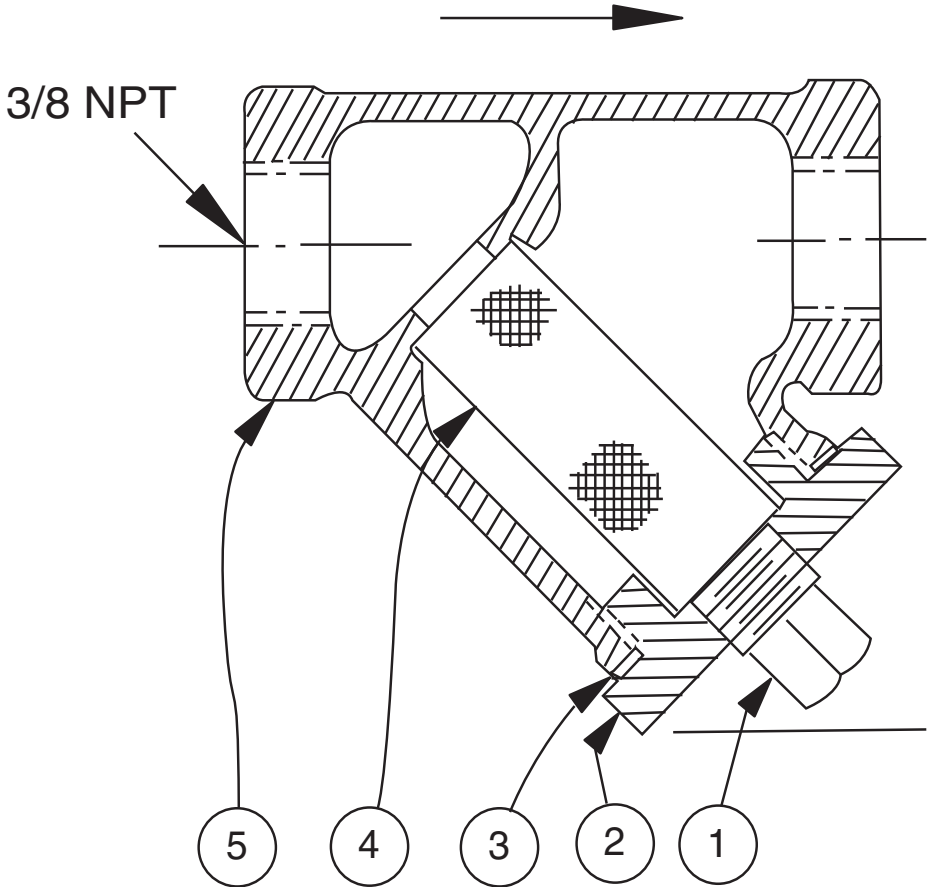



Cla-Val Product ID

HOW TO ORDER

PROPER IDENTIFICATION

For ordering repair kits, replacement parts, or for inquiries concerning valve operation, it is important to properly identify Cla-Val products already in service by including all nameplate data with your inquiry. Pertinent product data includes valve function, size, material, pressure rating, end details, type of pilot controls used and control adjustment ranges.

IDENTIFICATION PLATES

For product identification, cast-in body markings are supplemented by identification plates as illustrated on this page. The plates, depending on type and size of product, are mounted in the most practical position. **It is extremely important that these identification plates are not painted over, removed, or in any other way rendered illegible.**



This brass plate appears on altitude valves only and is found on top of the outlet flange.

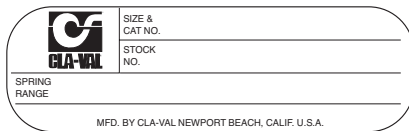

This tag is affixed to the cover of the pilot control valve. The adjustment range appears in the spring range section.

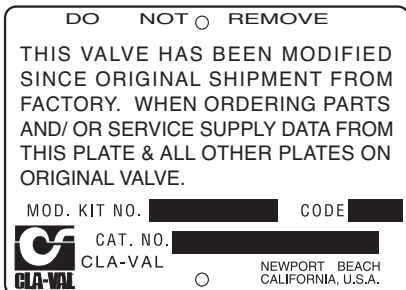

This aluminum plate is included in pilot system modification kits and is to be wired to the new pilot control system after installation.

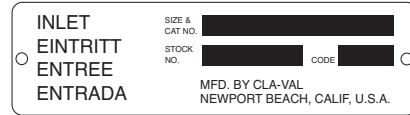

This brass plate appears on valves sized 2 1/2" and larger and is located on the top of the inlet flange.

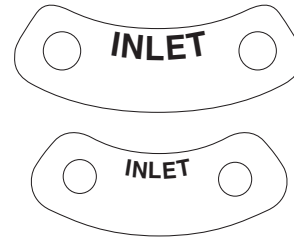

These two brass plates appear on 3/8", 1/2", and 3/4" size valves and are located on the valve cover.

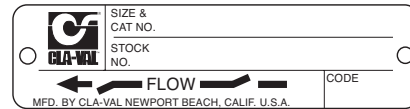

These two brass plates appear on threaded valves 1" through 3" size or flanged valves 1" through 2". It is located on only one side of the valve body.

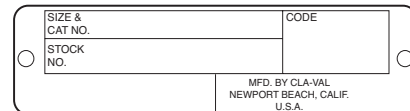

This brass plate is used to identify pilot control valves. The adjustment range is stamped into the plate.

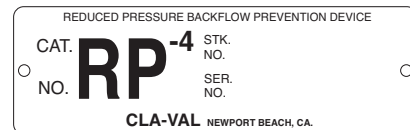

This brass plate is used on our backflow prevention assemblies. It is located on the side of the Number Two check (2" through 10"). The serial number of the assembly is also stamped on the top of the inlet flange of the Number One check.

How to Order

Because of the vast number of possible configurations and combinations available, many valves and controls are not shown in published product and price lists. For ordering information, price and availability on product that are not listed, please contact your local Cla-Val office or our factory office located at:

P. O. Box 1325
 Newport Beach, California 92659-0325
 (949) 722-4800
 FAX (949) 548-5441



When Ordering, Please Specify

- | | | | | |
|---------------------------|--------------------------------------|------------------------|----------------------------|----------------------|
| 1. Model Number | 3. Adjustment range (as application) | 4. Valve Size | 6. Body and Trim Materials | 7. Optional Features |
| 2. Globe or Angle Pattern | | 5. Threaded or Flanged | | 8. Pressure Class |

Unless Otherwise Specified

- Globe or angle pattern are the same price
- Ductile iron body and bronze trim are standard
- X46 Flow Clean Strainer or X43 "Y" Strainer are included
- CK2 Isolation Valves are included in price on 4" and larger valve sizes (6" and larger on 600 Series)

Limited Warranty

Automatic valves and controls as manufactured by Cla-Val are warranted for three years from date of shipment against manufacturing defects in material and workmanship that develop in the service for which they are designed, provided the products are installed and used in accordance with all applicable instructions and limitations issued by Cla-Val. Electronic components manufactured by Cla-Val are warranted for one year from the date of shipment.

We will repair or replace defective material, free of charge, that is returned to our factory, transportation charges prepaid, if upon inspection, the material is found to have been defective at time of

original shipment. This warranty is expressly conditioned on the purchaser's providing written notification to Cla-Val immediate upon discovery of the defect.

Components used by Cla-Val but manufactured by others, are warranted only to the extent of that manufacturer's guarantee.

This warranty shall not apply if the product has been altered or repaired by others, Cla-Val shall make no allowance or credit for such repairs or alterations unless authorized in writing by Cla-Val.

Disclaimer of Warranties and Limitations of Liability

The foregoing warranty is exclusive and in lieu of all other warranties and representations, whether expressed, implied, oral or written, including but not limited to any implied warranties or merchantability or fitness for a particular purpose. All such other warranties and representations are hereby canceled.

Cla-Val shall not be liable for any incidental or consequential loss, damage or expense arising directly or indirectly from the use of the

product. Cla-Val shall not be liable for any damages or charges for labor or expense in making repairs or adjustments to the product. Cla-Val shall not be liable for any damages or charges sustained in the adaptation or use of its engineering data and services. No representative of Cla-Val may change any of the foregoing or assume any additional liability or responsibility in connection with the product. The liability of Cla-Val is limited to material replacements F.O.B. Newport Beach, California.

Terms of Sale

ACCEPTANCE OF ORDERS

All orders are subject to acceptance by our main office at Newport Beach, California.

CREDIT TERMS

Credit terms are net thirty (30) days from date of invoice.

PURCHASE ORDER FORMS

Orders submitted on customer's own purchase order forms will be accepted only with the express understanding that no statements, clauses, or conditions contained in said order form will be binding on the Seller if they in any way modify the Seller's own terms and conditions of sales.

PRODUCT CHANGES

The right is reserved to make changes in pattern, design or materials when deemed necessary, without prior notice.

PRICES

All prices are F.O.B. Newport Beach, California unless expressly stated otherwise on our acknowledgment of the order. Prices are subject to change without notice. The prices at which any order is accepted are subject to adjustment to the Seller's price in effect at the time of shipment. Prices do not include sales, excise, municipal, state or any other Government taxes. Minimum order charge \$100.00.

RESPONSIBILITY

We will not be responsible for delays resulting from strikes, accidents, negligence of carriers, or other causes beyond our control. Also, we will not be liable for any unauthorized product alterations or charges accruing there from.

RISK

All goods are shipped at the risk of the purchaser after they have been delivered by us to the carrier. Claims for error, shortages, etc., must be made upon receipt of goods.

EXPORT SHIPMENTS

Export shipments are subject to an additional charge for export packing.

RETURNED GOODS

1. Customers must obtain written approval from Cla-Val prior to returning any material.
2. Cla-Val reserves the right to refuse the return of any products.
3. Products more than six (6) months old cannot be returned for credit.
4. Specially produced, non-standard models cannot be returned for credit.
5. Rubber goods such as diaphragms, discs, o-rings, etc., cannot be returned for credit, unless as part of an unopened vacuum sealed repair kit which is less than six months old.
6. Goods authorized for return are subject to a 35% (\$100 minimum) restocking charge and a service charge for inspection, reconditioning, replacement of rubber parts, retesting, repainting and repackaging as required.
7. Authorized returned goods must be packaged and shipped prepaid to Cla-Val, 1701 Placentia Avenue, Costa Mesa, California 92627.





Model Repair Kits

Model 100-01 Hytrol Main Valve

BUNA-N MATERIAL				
	RUBBER KIT STOCK #	REPAIR KIT STOCK #	REBUILD ASSEMBLY STOCK #	STUD & NUT KIT STOCK #
3/8"	9169801K		21176614B	21176633J
1/2"	9169802H	21176602F	21176615A	21176634H
3/4"	9169802H	21176602F	21176615A	21176634H
1" Non-Guided	9169803F	21176601G	21176616K	21176636F
1"	9169804D	21176603E	21176617J	21176636F
1 1/4"	9169804D	21176603E	21176617J	21176636F
1 1/2"	9169804D	21176603E	21176617J	21176636F
2"	9169805A	21176608K	21176618H	21176637E
2 1/2"	9169811J	21176609J	21176619G	21176638D
3"	9169812G	21176604D	21176620D	21176639C
4"	9169813E	21176605C	21176621C	21176640K
6"	9169815K	21176606B	21176622B	21176641J
8"	9817901D	21176607A	21176623A	21176642H
10"	9817902B	21176610F	21176654C	21176643G
12"	9817903K	21176611E	21176625J	21176644F
14"	9817904H	21176612D	21176626H	21176645E
16"	9817905E	21176613C	21176627G	21176645E

Model 100-20 Hytrol Main Valve

BUNA-N MATERIAL				
	RUBBER KIT STOCK #	REPAIR KIT STOCK #	REBUILD ASSEMBLY STOCK #	STUD & NUT KIT STOCK #
3"	9169805A	21176608K	21176618H	21176637E
4"	9169812G	21176604D	21176620D	21176639C
6"	9169813E	21176605C	21176621C	21176640K
8"	9169815K	21176606B	21176622B	21176641J
10"	9817901D	21176607A	21176623A	21176642H
12"	9817902B	21176610F	21176624K	21176643G
14"	9817903K	21176611E	21176625J	21176644F
16"	9817903K	21176611E	21176625J	21176644F

Model 100-30 Hytrol Main Valve

BUNA-N MATERIAL		
	RUBBER KIT STOCK #	REBUILD ASSEMBLY STOCK #
2 1/2"	21112704H	21235401C
3"	21112702K	21235402B
4"	21112703J	21235403A
6"	27496886J	21235404K
8"	21112701A	21235405J
10"	CF	21235406H

- Rubber Kit Includes:** Diaphragm, Disc, Spacer Washers. **Model 100-30 also includes:** Stem O-Ring, Seal, Bearing O-Ring.
- Repair Kit Includes:** Diaphragm, Disc, Spacer Washers, Epoxy Coated Disc Retainer, Epoxy Coated Diaphragm Washer, Protective Washer
- Rebuild Assembly Includes:** Diaphragm, Disc, Spacer Washers, Epoxy Coated Disc Retainer, Epoxy Coated Diaphragm Washer, Protective Washer, Stainless Steel Bolts & Washers (6" & Below), Stainless Steel Studs, Nuts, & Washers (8" & Above), Stem, Stem Nut, Disc Guide, Standard Cover Spring, Cover Washer. **Model 100-30 also includes:** Upper and Lower Stem and Stem Nut, Stem O-Ring, Seal, Lower Spring, PU Bearing, Bearing O-Ring, Bearing Retainer Ring.
- Stud & Nut Kit Includes:** Stainless Steel Bolts & Washers (6" & Below), Stainless Steel Studs, Nuts, & Washers (8" & Above)



Repair Kits for 100-02/100-21 Powertrol and 100-03/100-22 Powercheck Main Valves

For: Powertrol and Powercheck Main Valves—150 Pressure Class Only

Includes: Diaphragm, Disc (or Disc Assembly) and O-rings and full set of spare Spacer Washers.

Valve Size	Kit Stock Number		Valve Size	Kit Stock Number	
	100-02			100-02 & 100-03	100-21 & 100-22
3/8"	9169901H		2 1/2"	9169910J	N/A
1/2" & 3/4"	9169902F		3"	9169911G	9169905J
1"	9169903D		4"	9169912E	9169911G
1 1/4" & 1 1/2"	9169904B		6"	9169913C	9169912E
2"	9169905J		8"	9169950E	9169913C
			10"	9169939H	9169950E
			12"	9169937B	9169939H

Consult factory for larger sizes

Repair Kits for 100-04/100-23 Hy-Check Main Valves

For: Hy-Check Main Valves—150 Pressure Class Only

Includes: Diaphragm, Disc and O-Rings and full set of spare Spacer Washers.

Valve Size	Kit Stock Number		Valve Size	Kit Stock Number	
	100-04	100-23		100-04	100-23
4"	20210901B	N/A	12"	20210905H	20210904J
6"	20210902A	20210901B	14"	20210906G	N/A
8"	20210903K	20210902A	16"	20210907F	20210905H
10"	20210904J	20210903K	20"	N/A	20210907F
			24"	N/A	20210907F

Consult factory for larger sizes

Repair Kits for Pilot Control Valves (In Standard Materials Only)

Includes: Diaphragm, Disc (or Disc Assembly), O-Rings, Gaskets or spare Screws as appropriate.

BUNA-N® (Standard Material)				VITON (For KB Controls)	
Pilot Control	Kit Stock Number	Pilot Control	Kit Stock Number	Pilot Control	Kit Stock Number
CDB	9170006C	CFM-7A	1263901K	CDB-KB	9170012A
CDB-30	9170023H	CFM-9	12223E	CRA-KB	N/A
CDB-31	9170024F	CRA (w/bucking spring)	9170001D	CRD-KB (w/bucking spring)	9170008J
CDB-7	9170017K	CRD (w/bucking spring)	9170002B	CRL-KB	9170013J
CDH-2	18225D	CRD (no bucking spring)	9170003K	CDHS-2BKB	9170010E
CDHS-2	44607A	CRD-18	20275401K	CDHS-2FKB	9170011C
CDHS-2B	9170004H	CRD-22	98923G	CDHS-18KB (no bucking spring)	9170009G
CDHS-2F	9170005E	CRL (55F, 55L)	9170007A	102C-KB	1726202D
CDHS-3C-A2	24657K	CRL60/55L-60	9170033G		
CDHS-8A	2666901A	CRL60/55L60 1"	9170042H		
CDHS-18	9170003K	CRL-4A	43413E		
CDS-4	9170014G	CRL-5 (55B)	65755B		
CDS-5	14200A	CRL-5A (55G)	20666E		
CDS-6	20119301A	CRL-18	20309801C		
CDS-6A	20349401C	Universal CRL	9170041K		
CDS-7	20349402B	CV	9170019F		
CDS-7DO	20349403A	X105L (O-ring)	00951E		
CFCM-M1	1222301C	102B-1	1502201F	Buna-N®	
CFM-2	12223E	102C-2	1726201F	CRD Disc Ret. (Solid)	C5256H
CFM-7	1263901K	102C-3	1726201F	CRD Disc Ret. (Spring)	C5255K

Repair Assemblies (In Standard Materials Only)

Control	Description	Stock Number
CF1-C1	Pilot Assembly Only	89541H
CF1-CI	Complete Float Control less Ball and Rod	89016A
CFC2-C1	Disc, Distributor and Seals	2674701E
CSM 11-A2-2	Mechanical Parts Assembly	97544B
CSM 11-A2-2	Pilot Assembly Only	18053K
33A 1"	Complete Internal Assembly and Seal	2036030B
33A 2"	Complete Internal Assembly and Seal	2040830J

When ordering, please give complete nameplate data of the valve and/or control being repaired. MINIMUM ORDER CHARGE APPLIES