

---

# CLA-VAL

**AUTOMATIC CONTROL VALVES**

---

**750-01**

Place this manual with personnel responsible  
for maintenance of this valve

---



## *Installation*

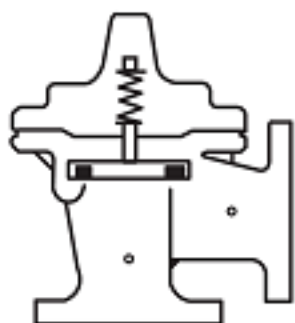

## *Operation*

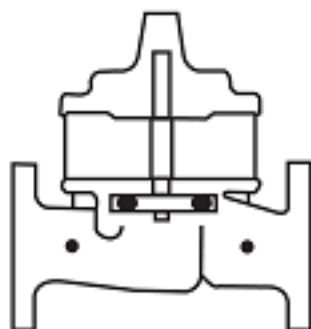

## *Maintenance*





## Recommended Inspections

Cla-Val recommends that an inspection be performed on our products annually. The inspection should include both a visual and functional test of the main valve/component and the pilot system. The inspection ensures that no damage or premature wear occurred due to velocity, pressure, or foreign matter within the fluid that may have exceeded the valve's design. Please consult the maintenance manual for specific information on the model. Manuals are available for download at [Cla-Val.com](http://Cla-Val.com), as well as contact information for a company representative.

Accurate record-keeping is a best practice for any preventative maintenance program, and Cla-Val strongly recommends this action through an asset management program. Cla-Val provides a free asset management tool, Link2Valves [Link2Valves - Cla-Val \(cla-val.com\)](http://Link2Valves - Cla-Val (cla-val.com)), to assist in preventative maintenance record-keeping and scheduling.

- Compact Design, Proven Reliable
- Light Weight Materials
- High Pressure Rating Availability
- Easy Installation and Maintenance



The Cla-Val Model 100-42 Roll Seal valve is a hydraulically operated valve used to control liquid flow by means of a flexible control element: the liner.

The basic valve consists of only two parts: a one piece, investment cast body and an elastomeric liner. The valve body is constructed with internal ribs and slots forming a grillwork which surrounds the liner to provide support. A normally closed type valve is formed by the installed liner which covers the grillwork and seats against the raised seating surface in the valve body.

Upstream pressure actuates the valve to produce valve opening by rolling the liner off the seating surface and the slotted grillwork.

The valve is actuated by upstream pressure as the loading pressure (pressure supplied to the control chamber) is varied by an external pilot control system.

A typical pilot control system used to operate the Model 100-42 valve consists of a restriction and a suitable pilot connected to the valve.

## Principle of Operation

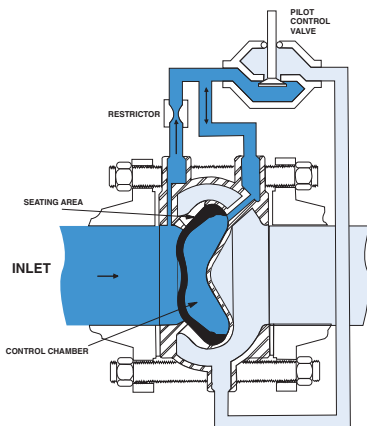

### Model 100-42 Valve in Closed Position

Upstream pressure is introduced to the control chamber (the chamber formed behind the liner) of the Cla-Val Model 100-42 Roll Seal valve through the control piping and restrictor. When the pilot is closed, full inlet pressure is supplied to the control chamber, thus balancing the force developed by inlet pressure acting on the upstream face on the liner. Under these conditions, the liner remains in the fully closed position. Since the operating pressure in the control chamber is greater than the outlet pressure, an additional closing force is developed across the liner, pressing the liner against the surrounding slotted grillwork area and seating surface.

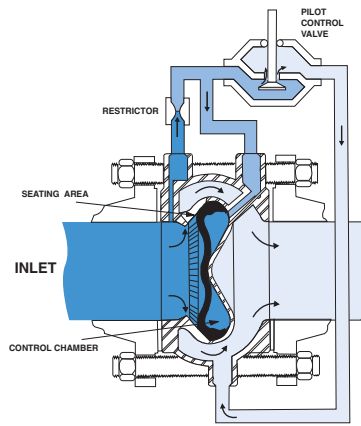

### Model 100-42 Valve in Partially Open Position

As loading pressure is lowered slightly below inlet pressure, the central portion of the liner is forced to invert and come to rest against the tip of the control chamber cavity. Reducing the loading pressure further (but still higher than outlet pressure) causes the liner to drape over the cone shaped portion of the control chamber cavity. This action causes the outer section of the liner to roll off the seating surface and a portion of the grillwork to partially open the valve.

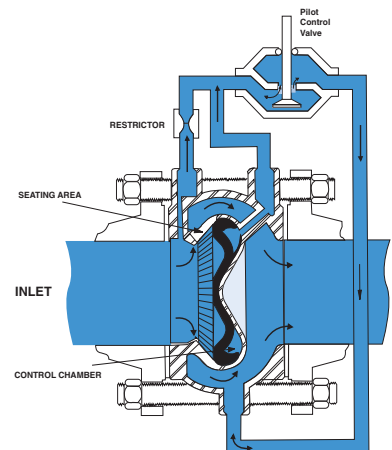

### Model 100-42 Valve in Fully Open Position

The valve is fully opened when loading pressure is sufficiently reduced to allow the liner to roll back completely and expose the full slot area. Restoring loading pressure reverses the liner rolling action to return the liner to the fully closed position.

## Design Specification

|                            |  |
|----------------------------|--|
| Sizes:                     | 2 - 6 inch/50 - 150 mm wafer style<br>6 - 12 inch/150 - 300 mm flanged   |
| End Detail Wafer:          | Fits ANSI B16.5 class 125, 150, 250, and 300 flanges   |
| End Detail Flanged:        | ANSI B16.5 class 150 (fits class 125) or ANSI B16.5 class 300 (fits class 250)                                   |
| Operating Pressure:        | 720 psi maximum  |
| Maximum Differential:      | 150 psid continuous, 225 psid intermittent*  |
| Reverse Pressure:          | 125 psid maximum   |
| Temperature Range:         | 32 to 160 degrees F*   |
| Flange Operating Pressure: | Class 125-175 psi maximum<br>Class 150-275 psi maximum<br>Class 250-300 psi maximum<br>Class 300-720 psi maximum |

\*Standard natural rubber 65 durometer in water service.  
Temperature range depends on liner material. Higher differential pressure ratings available.

For other than standard ANSI flanges consult factory

**Din drilling available on all sizes**

## Performance Specification

|                        |                                     |
|------------------------|-------------------------------------|
| Capacity:              | See Technical Data Sheet            |
| C <sub>f</sub> Factor: | 0.9                                 |
| Cavitation:            | See Technical Data Sheet            |
| Rangeability:          | 500:1                               |
| Bearing Friction:      | No friction from slip-type bearings |

## Material Specification

|                    |  |
|--------------------|--|
| Body:              | 316L Stainless Steel   |
| Flanges: (Slip on) | Carbon Steel/Clear Cad. Plated   |
| Bolt Kit:          | Carbon Steel/Zinc Plated   |
| Liner:             | Natural Rubber, 65 duro (standard)<br>Viton, EPDM, Nitrile, Silicone (available) |
| Liner Retainer:    | 316 Stainless Steel  |

## Optional Materials

Escaloy 45D  
Duplex Stainless Steel  
Super Duplex Stainless Steel  
Nickel Aluminum Bronze  
Titanium

## Dimensions (100-42 Main Valve)

| Valve Size (Inches)                           | 2    | 3    | 4    | 6     | 8     | 10    | 12    |
|---|------|------|------|-------|-------|-------|-------|
| A   | 2.88 | 3.56 | 4.13 | 5.25  | —     | —     | —     |
| B   | —    | —    | —    | 10.88 | 14.38 | 18.00 | 21.63 |
| BB  | 4.38 | 5.88 | 7.38 | 9.81  | —     | —     | —     |
| C   | —    | —    | —    | 9.00  | 11.00 | 13.00 | 15.25 |
| CC  | 2.50 | 3.25 | 4.00 | 5.50  | —     | —     | —     |
| D 150 ANSI                                    | —    | —    | —    | 11.00 | 13.50 | 16.00 | 19.00 |
| D 300 ANSI                                    | —    | —    | —    | 12.50 | 15.00 | 17.50 | 20.50 |
| E Ports NPT                                   | —    | —    | —    | 0.38  | 0.38  | 0.50  | 0.50  |
| Approx. Wt. Lbs. (150 lbs.)                   | 4    | 7.5  | 14   | 58    | 115   | 190   | 290   |
| Approx. Wt. Lbs. (150 lbs.) with Studs & Nuts | 6    | 10   | 22   | —     | —     | —     | —     |
| Approx. Wt. Lbs. (300 lbs.)                   | 4    | 7.5  | 14   | 87    | 155   | 250   | 375   |
| Approx. Wt. Lbs. (300 lbs.) with Studs & Nuts | 11   | 14   | 26   | —     | —     | —     | —     |
| Max. Continuous Flow (gpm)                    | 224  | 469  | 794  | 1787  | 3177  | 4964  | 7148  |

| Valve Size (mm)                              | 50   | 80  | 100 | 150  | 200  | 250  | 300  |
|--|------|-----|-----|------|------|------|------|
| A  | 73   | 90  | 105 | 133  | —    | —    | —    |
| B  | —    | —   | —   | 276  | 356  | 457  | 549  |
| BB   | 111  | 149 | 187 | 249  | —    | —    | —    |
| C  | —    | —   | —   | 229  | 279  | 330  | 387  |
| CC   | 64   | 83  | 102 | 140  | —    | —    | —    |
| D 150 ANSI                                   | —    | —   | —   | 279  | 343  | 406  | 483  |
| D 300 ANSI                                   | —    | —   | —   | 318  | 381  | 445  | 521  |
| E Ports NPT                                  | —    | —   | —   | 0.38 | 0.38 | 0.50 | 0.50 |
| Approx. Wt. Kg. (150 lbs.)                   | 1.81 | 4   | 6   | 30   | 54   | 89   | 152  |
| Approx. Wt. Kg. (150 lbs.) with Studs & Nuts | 3    | 5   | 10  | —    | —    | —    | —    |
| Approx. Wt. Kg. (300 lbs.)                   | 1.81 | 4   | 6   | 42   | 73   | 117  | 191  |
| Approx. Wt. Kg. (300 lbs.) with Studs & Nuts | 5    | 6   | 12  | —    | —    | —    | —    |
| Max. Continuous Flow (l/s)                   | 14   | 30  | 50  | 113  | 200  | 301  | 451  |

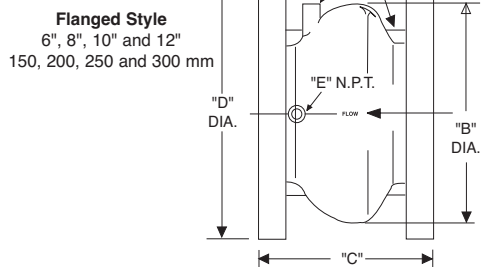
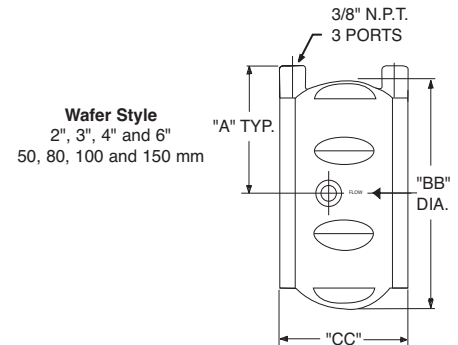

## When Ordering Please Specify:

- Catalog No. 100-42
- Valve Size
- Fluid Being Handled
- Fluid Temperature Range
- Inlet Pressure Range
- Outlet Pressure Range
- Maximum Differential Pressure
- Minimum Differential Pressure
- Maximum Flow Rate



## CLA-VAL

1701 Placentia Avenue • Costa Mesa, CA 92627  
800-942-6326 • Fax: 949-548-5441 • Web Site: [cla-val.com](http://cla-val.com) • E-mail: [info@cla-val.com](mailto:info@cla-val.com)

**CLA-VAL CANADA**  
4687 Christie Drive  
Beamsville, Ontario  
Canada L0R 1B4  
Phone: 905-563-4963  
E-mail [sales@cla-val.ca](mailto:sales@cla-val.ca)

**CLA-VAL EUROPE**  
Chemin des Mésanges 1  
CH-1032 Romanel/  
Lausanne, Switzerland  
Phone: 41-21-643-15-55  
E-mail: [cla-val@cla-val.ch](mailto:cla-val@cla-val.ch)

**CLA-VAL UK**  
Dainton House, Goods Station Road  
Tunbridge Wells  
Kent TN1 2 DH England  
Phone: 44-1892-514-400  
E-mail: [info@cla-val.co.uk](mailto:info@cla-val.co.uk)

**CLA-VAL FRANCE**  
Porte du Grand Lyon 1  
ZAC du Champ du Périer  
France - 01700 Neyron  
Phone: 33-4-72-25-92-93  
E-mail: [cla-val@cla-val.fr](mailto:cla-val@cla-val.fr)

**CLA-VAL PACIFIC**  
45 Kennaway Road  
Woolston, Christchurch, 8023  
New Zealand  
Phone: 64-39644860  
[www.cla-valpacific.com](http://www.cla-valpacific.com)  
E-mail: [info@cla-valpacific.com](mailto:info@cla-valpacific.com)



— SERIES — **100-42**

# 700 Series Roll Seal

## DESCRIPTION

The Cla-Val Model 100-42 Roll Seal valve is a hydraulically operated valve used to control liquid flow by means of a flexible control element, the liner.

The basic valve consists of only two parts: a one piece, investment cast body and an elastomeric liner. The valve body is constructed with internal ribs and slots forming a grillwork which surrounds the liner to provide support. A normally closed type valve is formed by the installed liner which covers the grillwork and seats against the raised seating surface in the valve body.

Upstream pressure actuates the valve to produce valve opening by rolling the liner off the seating surface and the slotted grillwork.

The valve is actuated by upstream pressure as the loading pressure (pressure supplied to the control chamber) is varied by an external pilot control system.

A typical pilot control system used to operate the Model 100-42 valve consists of a restriction and a suitable pilot connected to the valve.



## PRINCIPLE OF OPERATION

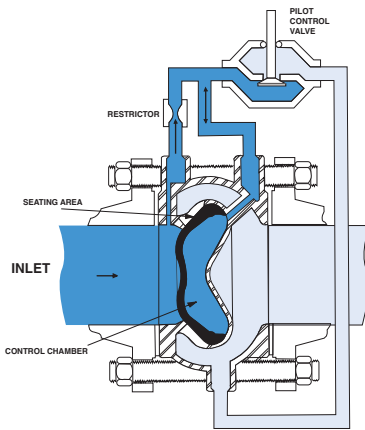

**Model 100-42 Valve  
in Closed Position**

Upstream pressure is introduced to the control chamber (the chamber formed behind the liner) through the control piping and restrictor. When the pilot is closed, full inlet pressure is supplied to the control chamber, thus balancing the force developed by inlet pressure acting on the upstream face on the liner. Under these conditions, the liner remains in the fully closed position.

Since the operating pressure in the control chamber is greater than the outlet pressure, an additional closing force is developed across the liner, pressing the liner against the surrounding slotted grillwork area and seating surface.

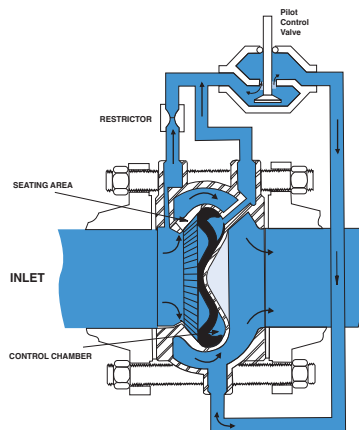

**Model 100-42 Valve  
in Partially Open Position**

As loading pressure is lowered slightly below inlet pressure, the central portion of the liner is forced to invert and come to rest against the tip of the control chamber cavity. Reducing the loading pressure further (but still higher than outlet pressure) causes the liner to drape over the cone shaped portion of the control chamber cavity. This action causes the outer section of the liner to roll off the seating surface and a portion of the grillwork to partially open the valve.

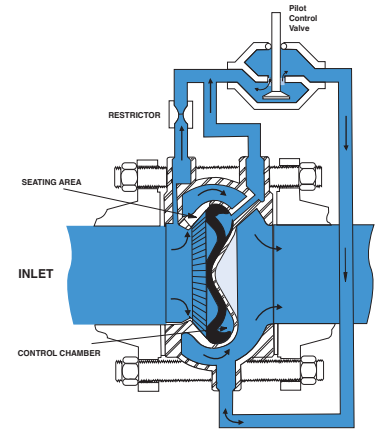

**Model 100-42 Valve  
in Fully Open Position**

The valve is fully opened when loading pressure is sufficiently reduced to allow the liner to roll back completely and expose the full slot area. Restoring loading pressure reverses the liner rolling action to return the liner to the fully closed position.

---

---

## INSTALLATION

The Cla-Val Model 100-42 Roll Seal valve in 2", 3", and 4" sizes are designed to mount between standard pipe flanges (ANSI 125, 150, 250, and 300 series) as a wafer type valve. The outer portion of the valve body is constructed with fluted (recessed) sections to provide clearance for the class 125 and 150 flange bolt pattern while the basic outside diameter of the body centers within the class 250 and 300 flange bolt pattern.

The Model 100-42 valve in 6" through 12" sizes are constructed with separable "slip-on" style flanges. Furnished standard in either class 150 or 300 raised face type, the flanges are removable and interchangeable. The class 150 flange may be bolted up to class 125 pipeline flanges and the class 300 flange may be mated against a class 250 flange.

Locate pilot system port connections at the top of valve in pipeline to allow easy air venting. A line size strainer is recommended, mounted on the valve inlet.

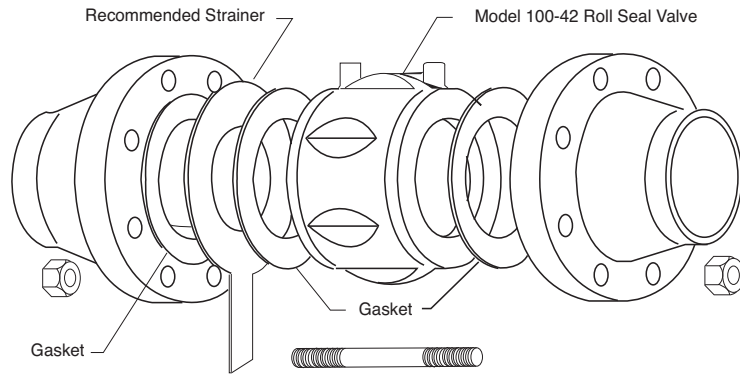

---

## PROCEDURE

1. The valve should be given a visual inspection before installation to be sure no foreign materials have collected inside the valve during shipment or storage.
  2. Pipelines should be flushed out before the valve is installed in the system. New systems, especially, should be cleaned as contaminants such as welding beads, scale, rocks, etc. are commonly contained within the pipeline.
  3. The valve should be installed in a location allowing sufficient working space around the valve to provide easy access for maintenance and removal for servicing.
  4. For 2", 3", and 4" sizes only. Insert the lower half pattern of stud bolts through the bolt holes of the upstream and downstream pipeline flanges.
  - 4a. For 2" & 3" valves only. The 125 and 150 series flanges use a different number of bolts than the 250 and 300 series flanges. Hence, the wafer valve body configuration is inherently self centering regardless of the flange used.
  - 4b. For the 4" valve, ANSI pipe flanges use an 8 bolt pattern regardless of pressure ratings, although the 250 and 300 series use larger bolts on a larger bolt circle. The 4" valve can be centered in the larger 250 and 300 class flanges by rotating the valve body into full radial contact with the bolt studs prior to tightening.
  5. If an inline basket type strainer is to be included in the installation, insert the strainer into the upstream pipe, making sure a gasket is placed between the strainer and the upstream flange.
  6. Install the valve between the flanges being sure to include the appropriate flange gaskets between each end of the valve and the mating pipe flange.
- Note: The valve must be installed with the flow arrow on side of body pointing to the downstream piping section. Cla-Val 700 Series valves may be installed in any position in either vertical or horizontal installations without any effect on valve operation.
7. Insert the remaining stud bolts and nuts and tighten evenly using a diagonal cross-over type pattern.

### Liner Retainer Removal 2"-12" Sizes

The 2" and 3" liner retainer is secured to the valve with an Allen screw. Loosen the Allen screw, pull the locking pin back towards center of retainer, and remove the retainer from valve.

To install, insert the retainer, (do not block inlet feed hole), push locking pin into position and tighten Allen screw.

The 4"-12" liner retainers are secured with a snap ring. Remove the snap ring and retainer.

To install, insert retainer and install snap ring into the groove of valve. Be sure snap ring is completely inserted into groove.

### Liner Removal 2"-12" Sizes

The tool used for removal should be free of sharp edges to prevent damage to the liner, the valve body seat or control chamber surfaces. A motorcycle tire iron or similar tool works well.

1. Insert the tool between the liner and the valve body as deeply as possible.
2. Using the seat edge as a fulcrum, rock the end of the tool away from the valve in a manner to pull the liner bead out of the body. Grasp the liner and remove from the valve body.

### Liner Installation 2", 3", 4" Sizes

Thoroughly clean out the interior of the valve body control chamber cavity.

Liberal apply glycerine inside the control chamber cavity and around the seal bead area of the liner.

**DO NOT USE ANY HYDROCARBON OR SILICONE BASED LUBRICANTS ON LINERS AS THESE COMPOUNDS CAN SEVERELY ATTACK THE LINER MATERIAL.**

3. Fold the liner as shown and install into the valve body control chamber as deeply as possible.
4. Continuing to force the liner into the control chamber cavity, again fold the liner as shown to insert the liner seal bead section under the valve body seat surface.
5. Work the folded section of the liner into place by pushing against the folded area to slide the seal bead down the conical face of the control chamber.

### Liner Seating Instructions 2", 3", 4" Sizes

After installing the liner, it must be seated over the manifold ring in the valve body. The objective of this seating procedure is to place the inside lip of the liner over the outside lip of the manifold ring.

6. 4" valve with liner installed.
7. Pinch, pull and knead the liner 360° around to seat the liner on the manifold ring.
8. Using a dull tool or hammer handle, pry the outer part of the liner towards the center to help "seat" the liner.
9. Now push the liner down into the valve, holding your hand on the depressed liner, seal off the loading port with your finger.
10. Remove your hand from liner and continue holding your finger over the loading port. If liner is seated, it will be held in the open position as long as your finger is over the loading port. When you release your finger, the liner will pop up. If not seated, repeat with Step 7.

Install liner retainer into body.



1



2

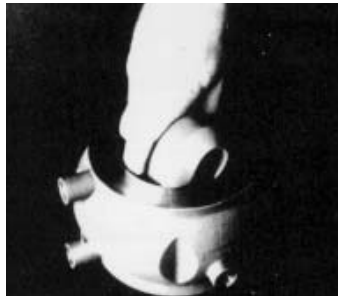

3



4



5



6



7



8



9



10

## Liner Installation

### 6", 8", 10", 12" sizes

1. Tools required: Bottle of drugstore glycerine, 30" crowbar, double headed plastic hammer with 14" handle, rubber mallet and large flat blade screwdriver.
2. Liberally wipe glycerine on the inside of the valve and on the outer edge of the liner. Fold liner in half and insert into valve body.
3. Push liner in as far as possible forcing it out side ways.
4. Place the crowbar at the upper 25% point of the liner. Take your other hand and push on nose of liner to bend the liner over the crowbar. The less material folded over, the easier it will go into the valve. If too much is folded over, it will be difficult to complete liner installation.
5. Continue bending liner nose down into the valve. Use your hands and/or hammer handle to continue forcing it down into valve. It is important to keep the "V" of the bend near the 25% point. If it goes over the center, The liner won't go in, and it will be necessary to start over at Step 3.
6. Use the hammer to force the liner down and out into the valve body.
7. Use the hammer handle for the final insertion. Sometimes it is helpful to beat on the liner with the hammer for the final step.
8. To seat the liner on the manifold ring use the hammer handle to push down on the liner near bore of valve inlet and pry handle and liner towards the center. Continue this prying action for 360° around the liner for proper seating.
9. To test for liner seating, push down on the center of liner and close the loading port shut-off cock, or block it with your hand. When you release your hand from the liner, it should remain in the down position until the loading port is opened.
10. If liner appears seated, open loading port cock and liner should pop-up to the closed position. Repeat Steps 6-10 if liner is not seated.

When the liner is fully seated, the inside diameter of the liner will be seated over the outside diameter of the manifold ring. The manifold ring is a raised circular ridge at the bottom of the open cavity which provides for even distribution of the fluid coming in and going out the loading port.

**Install liner retainer into body.**

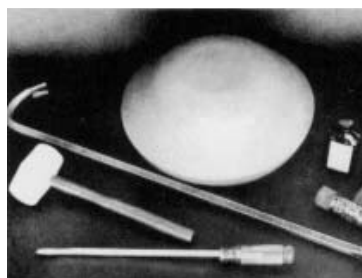

1

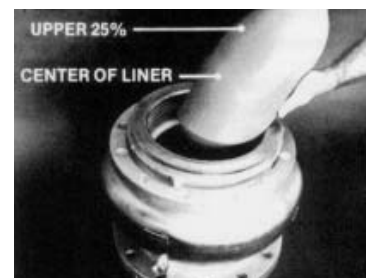

2



3



4



5



6



7



8



9



10

---

---

## PLACING VALVE INTO OPERATION **Important Procedure for All Installations:**

In most instances, the 700 Series Cla-Val Control valves will be shipped complete with a pilot control system mounted on the Model 100-42 valve. Consult the appropriate start up and operation instructions for the pilot control used before pressurizing the system.

IT IS IMPORTANT THAT THE PRESSURIZATION AND DEPRESSURIZATION OF ALL INSTALLATIONS BE CARRIED OUT IN A MANNER TO PREVENT IMPOSING A REVERSE PRESSURE CONDITION ON THE CLA-VAL MODEL 100-42 VALVE. PRESSURIZATION OF THE SYSTEM SHOULD BE ACCOMPLISHED BY PRESSURIZING THE INLET SIDE FIRST.

DEPRESSURIZATION OF THE SYSTEM SHOULD BE ACCOMPLISHED BY DEPRESSURIZING THE OUTLET SIDE FIRST. FAILURE TO FOLLOW THIS PROCEDURE COULD RESULT IN DISLODGE- MENT AND/OR DESTRUCTION OF THE RUBBER LINER.

---

## START-UP INSTRUCTIONS

### Pressure Reducing 790 Series Valves

The following instructions are for valves equipped with a Model CRD Pressure Reducing Pilot Control.

1. Remove the adjustment cap and back off adjustment screw setting (turn counterclockwise) of the CRD Pressure Reducing Pilot Control to fully relieve all loading on the range spring.
2. Slowly open the **upstream** main line block valve to pressurize the **inlet** section of the valve.
3. Bleed any entrapped air from the control chamber of the valve and tubing sections by loosening fittings at the highest points. Retighten fittings. Install gauge on downstream port of CRD.
4. Slowly increase tension on the range spring, by means of the adjustment screw (turn clockwise) until the desired downstream pressure is attained. Use a gauge.
5. Open the downstream main line block valve.
6. If required, reset the pilot adjustment screw setting to obtain the downstream pressure desired.
7. Tighten the adjustment screw lock nut and replace the adjustment cap.

### Back Pressure Control 750 Series Valves

The following instructions are for valves equipped with a Model CRL Back Pressure Pilot Control.

1. Remove the adjustment cap and increase tension on the range spring, by means of the adjustment screw (turn clockwise) until maximum spring load is attained.
2. Slowly open the **upstream** main line block valve to pressurize the **inlet** section of the valve.
3. Bleed any entrapped air from the control chamber of the valve and tubing sections by loosening fittings at the highest points. Retighten fittings.
4. Open the downstream main line block valve.
5. Gradually decrease tension on the range spring by means of the adjustment screw (turn counterclockwise) until upstream pressure decreases to the desired setpoint.
6. Tighten the adjustment screw lock nut and replace the adjustment cap.

### Relief Valve Applications 750 Series Valves

The following instructions are for valves equipped with a Model CRL Pressure Relief Pilot Control.

- Due to the nature of intended use, the system being protected with the relief valve will most likely not be able to furnish the pressure source needed to establish the proper setpoint of the pilot control. Due to this fact, in most instances, the relief valve setting procedures will either have to be carried out at other locations or an auxiliary pressure source will have to be supplied at the site in order to carry out the following procedure.
1. Remove the adjustment cap and increase tension on the range spring by means of the adjustment screw (turn clockwise) until maximum spring load is attained.
  2. Slowly introduce **inlet** pressure to the valve at the desired setpoint value. Bleed all air.
  3. Gradually decrease tension on the range spring by means of the adjustment screw (turn counterclockwise) until flow is initiated through the valve.
  4. Reduce system pressure back to normal value. Tighten the adjustment screw lock nut and replace the adjustment cap. The valve is now ready for service.

## Taking Valve Out of Service

The following procedure should be followed when taking the Model 100-42 valve out of service.

1. Close the upstream main line block valve first. Then close the downstream main line block valve.
  2. Vent the **downstream** section to fully relieve pressure in the outlet section of the valve.
  3. Vent the **upstream** section to fully relieve pressure in the inlet section and control chamber of the Model 100-42 valve.
  4. If the valve liner is to be inspected or replaced, remove the valve from the main line.
- 
-

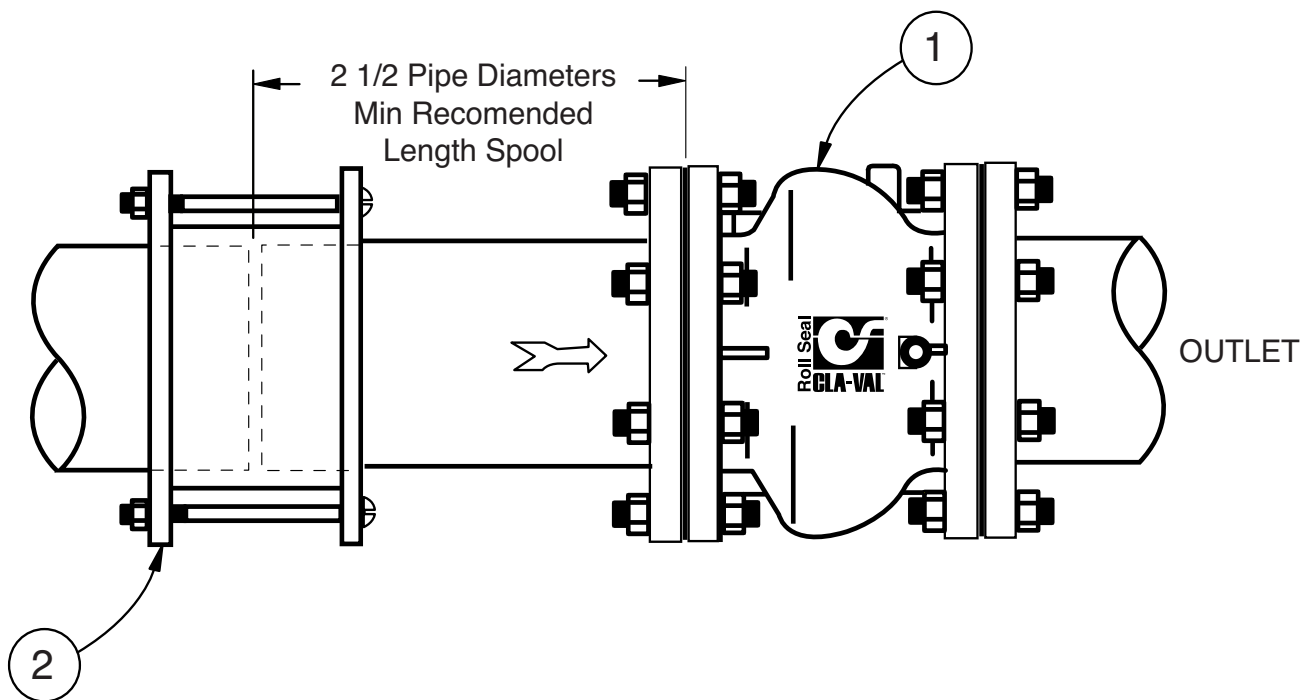

Recommended Pipe layout  
6" - 12" Flange style 100-42

- 2 Pipe Coupling (Rubber Gasket Type)
- 1 100-42 Main Valve, Flange X Flange

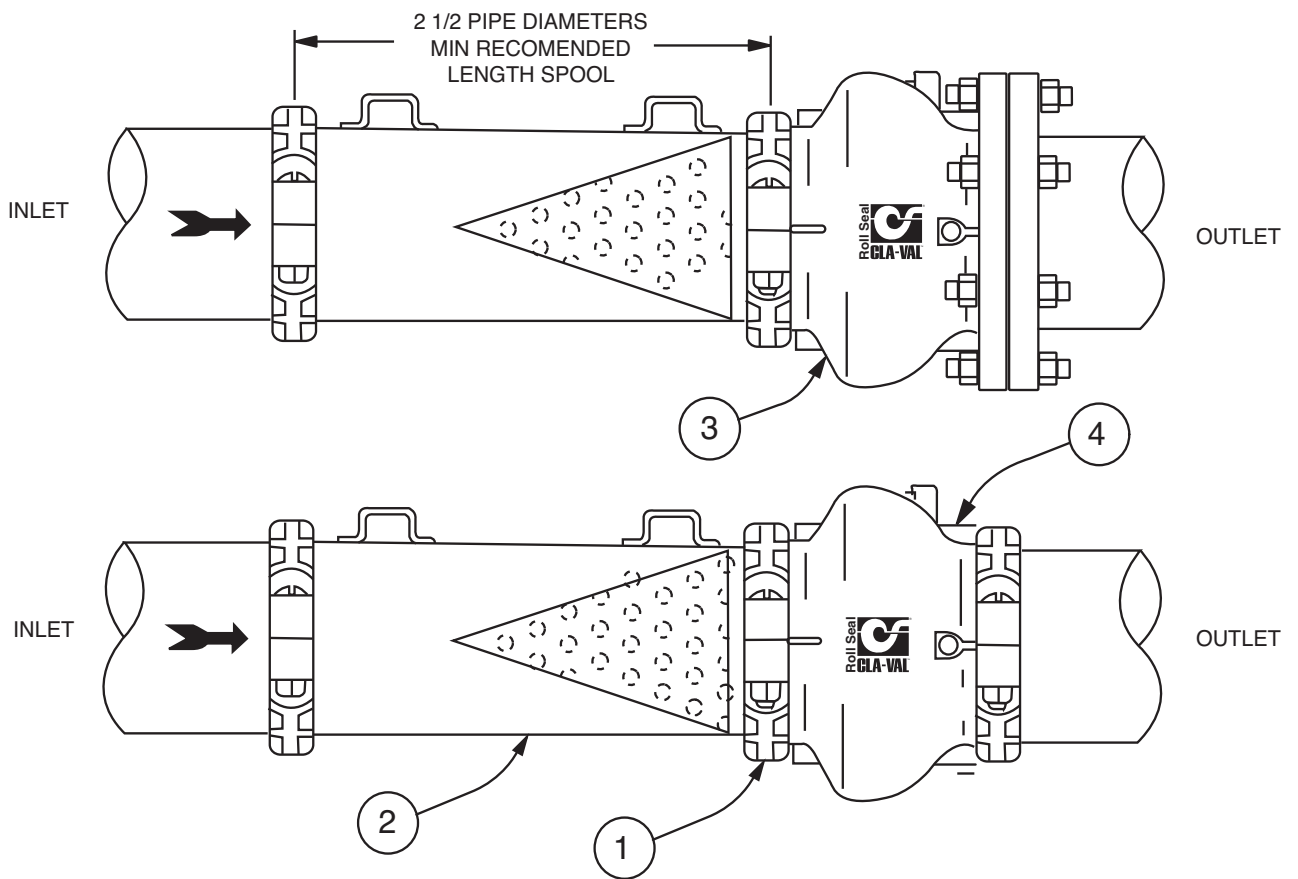

Recommended Pipe layout  
6" - 12" Grooved style 100-42

- 1 COUPLER FOR GROOVED PIPE
- 2 SPOOL STRAINER ASSEMBLY (WITH CONE)
- 3 100-42 MAIN VALVE, GROOVE X FLANGE
- 4 100-42 MAIN VALVE, GROOVE X GROOVE

**When ordering  
please specify:**

- All nameplate data
- Description
- Part Numbers
- Item Number
- Material

| Item No. | Description          | No. Req'd | Material (Standard)      |
|----------|----------------------|-----------|--------------------------|
| 1        | Body                 | 1         | 316L Stainless Steel "L" |
| 2*       | Liner                | 1         | Natural Rubber           |
| 3        | Nameplate            | 1         | Aluminum                 |
| 4        | Drive Screw          | 2         | 18-8 Stainless Steel     |
| 5        | Liner Retainer       | 1         | 316L Stainless Steel     |
| 6        | Retaining Ring       | 1         | 316L Stainless Steel     |
| 7        | Slip-on Flange       | 2         | Steel-Cad. Pl.           |
| 8        | Flange Retainer Ring | 2         | Steel-Cad. Pl.           |

\*Recommended Spare Part

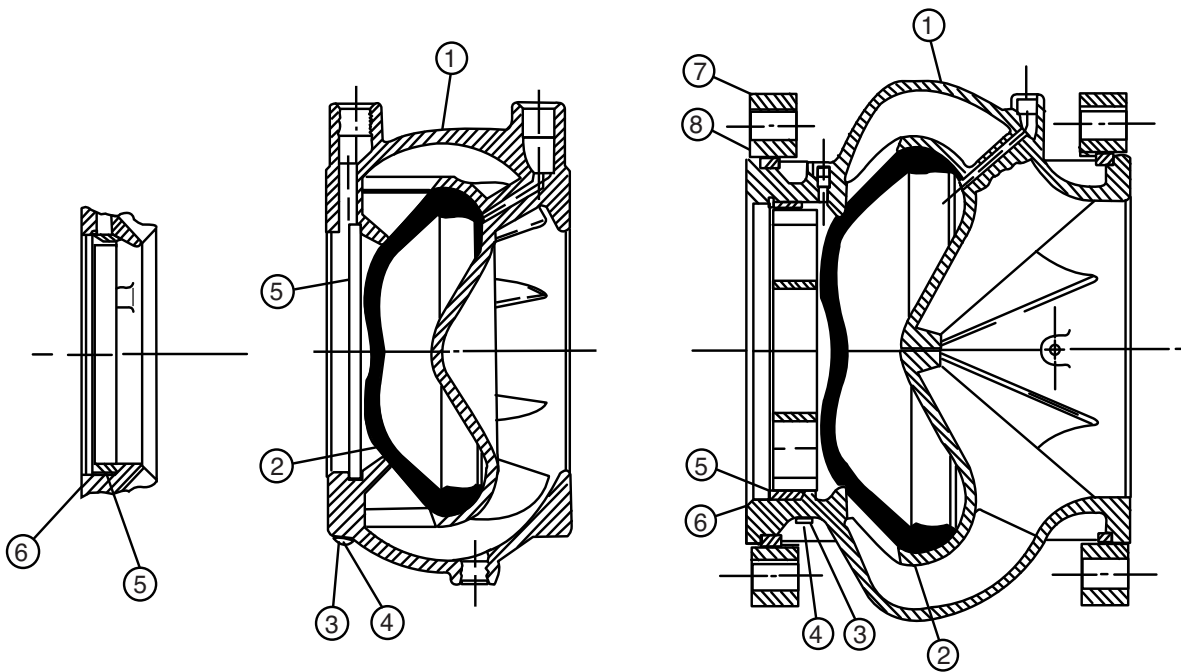

4" Wafer Style Valve

2-3" Wafer Style Valve

6"-12" Flanged Valve



# Model X42N-2 STRAINER AND NEEDLE VALVE ASSEMBLY

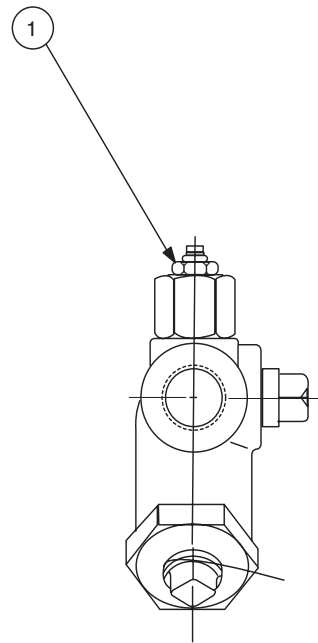
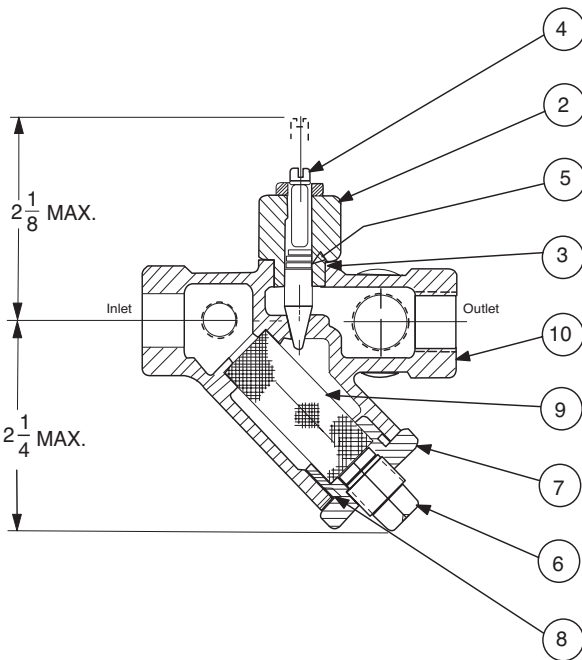
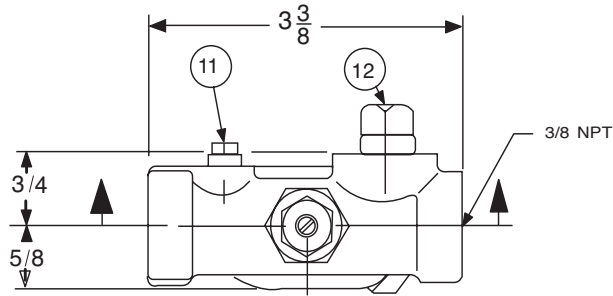

### When Ordering, Please Specify

1. All Nameplate data
2. Item Number
3. Description
4. Material

| Size        | Stock Number |
|-------------|--------------|
| 3/8" x 3/8" | 68372C       |

| Item No. | Description     | Material |
|----------|-----------------|----------|
| 1        | Jam Nut, Hex    | Sil Brz  |
| 2        | Bonnet          | S.S.     |
| 3        | O-Ring, Bonnet  | Syn Rub  |
| 4        | Stem            | S.S.     |
| 5        | O-Ring, Stem    | Syn Rub  |
| 6        | Plug, Pipe 1/4" | Bre.     |
| 7        | Strainer Plug   | 303      |
| 8        | O-Ring, Plug    | NBR      |
| 9        | Screen          | Monel    |
| 10       | Body            | Rd Brs   |
| 11       | Plug, Pipe 1/8" | Brass    |
| 12       | Plug, Pipe 3/8" | Brass    |





# Model CRL

## PRESSURE RELIEF CONTROL

### DESCRIPTION

The CRL Pressure Relief Control is a direct acting, spring loaded, diaphragm type relief valve. It may be used as a self-contained valve or as a pilot control for a Cla-Val Main valve. It opens and closes within very close pressure limits.

### OPERATION

The CRL Pressure Relief Control is normally held closed by the force of the compression spring above the diaphragm; control pressure is applied under the diaphragm. When the controlling pressure exceeds the spring setting, the disc is lifted off its seat, permitting flow through the control. When controlling pressure drops below spring setting, the spring returns the control to its normally closed position.

### INSTALLATION

The CRL Pressure Relief Control may be installed in any position. The control body (7) has one inlet and one outlet port with a side pipe plug (24) at each port. These plugs are used for control connections or gauge applications. The inlet in the power unit body (6) is the sensing line port. A flow arrow is marked on the body casting.

### ADJUSTMENT PROCEDURE

The CRL Pressure Relief Control can be adjusted to provide a relief setting at any point within the range found on the nameplate. Pressure adjustment is made by turning the adjustment screw (9) to vary the spring pressure on the diaphragm. Turning the adjustment screw clockwise increases the pressure required to open the valve. Counterclockwise decreases the pressure required to open the valve. When pressure adjustments are complete the jam nut (10) should be tightened and the protective cap (1) replaced. If there is a problem of tampering, lock wire holes have been provided in cap and cover. Wire the cap to cover and secure with lead seal.

### MAINTENANCE

#### Disassembly

The CRL Pressure Relief Control does not need to be removed from the line for disassembly. Make sure that pressure shut down is accompanied prior to disassembly. If the CRL is removed from the line for disassembly be sure to use a soft jawed vise to hold body during work. Refer to Parts List Drawing for Item Numbers.

1. Remove cap (1), loosen jam nut (10) and turn adjusting screw counterclockwise until spring tension is relieved.

2. Remove the eight screws (4) holding the cover (3) and powerunit body (6). Hold the cover and powerunit together and place on a suitable work surface. See NOTE under REASSEMBLY.

3. Remove the cover (3) from powerunit body (6). The spring (12) and two spring guides (11).

4. Remove nut (13) from stem (19) and slide off the belleville washer (14), the upper diaphragm washer (15) and the diaphragm (16).

5. Pull the stem (19) with the disc retainer assembly (21) through the bottom of powerunit. The lower diaphragm washer (17) will slide off of stem top.

6. Remove jam nut (23) and disc retainer assembly (21) from stem. Use soft jawed pliers or vise to hold stem. The polished surface of stem must not be scored or scratched.

7. The seat (22) need not be removed unless it is damaged. If removal is necessary use proper size socket wrench and turn counterclockwise. Note: Some models have an integral seat in the body (7).

#### Inspection

Inspect all parts for damage, or evidence of cross threading. Check diaphragm and disc retainer assembly for tears, abrasions or other damage. Check all metal parts for damage, corrosion or excessive wear.

#### Repair and Replacement

Minor nicks and scratches may be polished out using 400 grit wet or dry sandpaper fine emery or crocus cloth. Replace all O-rings and any damaged parts. When ordering replacement parts, be sure to specify parts list item number and all nameplate data.

#### Reassembly

In general, reassembly is the reverse of disassembly. However, the following steps should be observed:

1. Lubricate the O-Ring (18) with a small amount of a good grade of waterproof grease, (Dow Corning 44 medium grade or equal). Use grease sparingly and install O-ring in powerunit body (6).

2. Install stem (19) in powerunit body (6). Use a rotating motion with minimum pressure to let stem pass through O-ring. Do Not Cut O-Ring.

3. Install O-ring (5) at top of stem (19). Place lower diaphragm washer (17) on the stem with the serrated side up. Position diaphragm (16), upper diaphragm washer (15), with serration down, and belleville washer (14) with concave side down.

4. Position powerunit body (6) as shown on parts list drawing (top view).

5. Continue reassembly as outlined in disassembly steps 1 through 3.

#### Note:

Item (4) Screw will have a quantity of 8 for the 0-75 and 20-200psi design and a quantity of 4 for the 100-300psi design. Item (25) Screw is used on the 100-300psi design only. Install item (25), before item (4) for preload of item (12) spring.

| Service Suggestions  |  |   |
|--|--|---|
| Symptom  | Possible Cause   | Solutions   |
| Fails to open  | Controlling pressure too low.                              | Back off adjusting screw until valve opens.         |
| Fails to open with spring compression removed.                     | Mechanical obstruction, corrosion, scale build-up on stem. | Disassemble, locate, and remove obstruction, scale. |
| Leakage from cover vent hole when controlling pressure is applied. | Damaged diaphragm  | Disassembly replace damaged diaphragm.              |
|  | Loose diaphragm assembly.                                  | Tighten upper diaphragm washer.                     |
| Fails to close.  | No spring compression.                                     | Re-set pressure adjustment.                         |
| Fails to close with spring compressed.                             | Mechanical obstruction.                                    | Disassemble, locate and remove obstruction.         |



|   |   |                  |                     |                           |                             |   |                         |            |
|---|---|------------------|---------------------|---------------------------|-----------------------------|---|-------------------------|------------|
| AK  | 07-10-08  | AK               | 08-14-08            | PC                        | 10-1-2008                   |   |                         |            |
|   | <b>CLA-VAL CO.</b> NEWPORT BEACH, CALIFORNIA                      |                  | CATALOG NO.         |                           | DRAWING NO.<br><b>67783</b> | REV<br><b>BD</b>  |                         |            |
|   | TYPE OF VALVE AND MAIN FEATURES<br><br><b>CK2 COCK/BALL VALVE</b> |                  |                     |                           |                             | DESIGN<br>DRAWN MGR 4-02-80<br>CHK'D KD 4-03-80<br>APV'D CH 4-07-80 |                         |            |
| SCALE: NONE   |   |                  |                     |                           |                             |   |                         |            |
|   |   |                  |                     |                           |                             |   |                         |            |
| CLA-VAL PART NO. AND MATERIAL   |   |                  |                     |                           |                             |   |                         |            |
| BRONZE WITH HANDLE  | STEEL WITH HANDLE   | IRON WITH HANDLE | 316 SST WITH HANDLE | 316 SST W/ LOCKING HANDLE | BRONZE WITH HANDLE          | MONEL WITH HANDLE   | MONEL W/ LOCKING HANDLE | SIZE "NPT" |
| 67783-01K*  | -09C  | -17F             | -25J SUPSD BY-26G   |                           | -41F SUPSD BY-01K           |   |                         | 1/8"       |
| -02H  | -10A  | -18D             | -26G                | -51E SUPSD BY-26G<br>-52C | -42D SUPSD BY-02H           | -55F  |                         | 1/4"       |
| -03F *<br>-59H***   | -11J  | -19B             | -27E                | -46E SUPSD BY-27E<br>-53A | -45G<br>-57B**              | -48A SUPSD BY-49J   | -63K                    | 3/8"       |
| -04D<br>-60F***   | -12G  | -20K             | -28C                | -54J                      | -43B SUPSD BY-04D           | -49J  | -62B                    | 1/2"       |
| -05A<br>-61D***   | -13E  | -21H             | -29A                | -64H                      | -44K SUPSD BY-05A           | -56D  |                         | 3/4"       |
| -06J  | -14C  | -22F             | -30J                |                           |                             | -58K  |                         | 1"         |
| -07G  | -15K  | -23D             | -31G                |                           |                             |   |                         | 1 1/4"     |
| -08E  | -16H  | -24B             | -32E                |                           |                             |   |                         | 1 1/2"     |
| -50G  |   |                  | -47C                |                           |                             |   |                         | 2"         |
| * SEE ENGINEERING APPROVED VENDORS TABLE (SHEET 2 OF 2).<br>** HAMMOND VALVE 8501 ONLY.<br>*** WILKINS CK2 (SEE SHEET 2 OF 2) |   |                  |                     |                           |                             |   |                         |            |

"THIS DRAWING IS THE PROPERTY OF CLA-VAL CO. AND SAME AND COPIES MADE THEREOF, IF ANY, SHALL BE RETURNED TO IT UPON DEMAND. DELIVERY AND DISCLOSURE HEREOF ARE SOLELY UPON CONDITION THAT THE SAME SHALL NOT BE USED, COPIED OR REPRODUCED, NOR SHALL THE SUBJECT HEREOF BE DISCLOSED IN ANY MANNER TO ANYONE FOR ANY PURPOSE, EXCEPT AS HEREIN AUTHORIZED, WITHOUT PRIOR WRITTEN APPROVAL OF CLA-VAL CO. THIS DRAWING IS SUBMITTED CONFIDENTIALLY AND MAY NOT BE USED IN THE MANUFACTURE OF ANY MATERIAL OR PRODUCT OTHER THAN SUCH MATERIALS AND PRODUCTS FURNISHED TO CLA-VAL CO. WHETHER OR NOT THE EQUIPMENT OR INFORMATION SHOWN HEREON IS PATENTED OR OTHERWISE PROTECTED, FULL TITLE AND COPYRIGHTS, IF ANY, IN AND TO THIS DRAWING AND/OR INFORMATION DELIVERED OR SUBMITTED ARE FULLY RESERVED CLA-VAL CO."



# Model CV FLOW CONTROL

## DESCRIPTION

The CV Control is an adjustable restriction which acts as a needle valve when flow is in the direction of the stem. When flow is in the reverse direction, the port area opens fully to allow unrestricted flow. When installed in the control system of a Cla-Val automatic valve, it can be arranged to function as either an opening or closing speed control.

## OPERATION

The CV Flow Control permits full flow from port A to B, and restricted flow in the reverse direction. Flow from port A to B lifts the disc from seat, permitting full flow. Flow in the reverse direction seats the disc, causing fluid to pass through the clearance between the stem and the disc. This clearance can be increased, thereby increasing the restricted flow, by screwing the stem out, or counter-clockwise. Turning the stem in, or clockwise reduces the clearance between the stem and the disc, thereby reducing the restricted flow.

## INSTALLATION

Install the CV Flow Control as shown in the valve schematic. All connections must be tight to prevent leakage.

## DISASSEMBLY

Follow the sequence of the item numbers assigned to the parts in the cross sectional illustration for recommended order of disassembly.

Use a scribe, or similar sharp-pointed tool to remove O-ring from the stem.

## INSPECTION

Inspect all threads for damage or evidence of cross-threading. Check mating surface of seat and valve disc for excessive scoring or embedded foreign particles. Check spring for visible distortion, cracks and breaks. Inspect all parts for damage, corrosion and cleanliness.

## CLEANING

After disassembly and inspection, cleaning of the parts can begin. Water service usually will produce mineral or lime deposits on metal parts in contact with water. These deposits can be cleaned by dipping the parts in a 5-percent muriatic acid solution just long enough for deposits to dissolve. This will remove most of the common types of deposits. **CAUTION: Use extreme care when handling acid.** If the deposit is not removed by acid, then a fine grit (400) wet or dry sandpaper can be used with water. Rinse parts in water before handling. An appropriate solvent can clean parts used in fueling service. Dry with compressed air or a clean, lint-free cloth. Protect from damage and dust until reassembled.

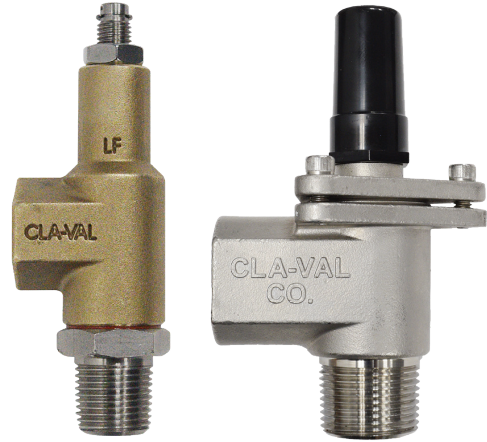

## REPAIR AND REPLACEMENT

Minor nicks and scratches may be polished out using a fine grade of emery or crocus cloth; replace parts if scratches cannot be removed.

Replace O-ring packing and gasket each time CV Flow Control is overhauled.

Replace all parts which are defective. Replace any parts which create the slightest doubt that they will not afford completely satisfactory operation. Use Inspection steps as a guide.

## REASSEMBLY

Reassembly is the reverse of disassembly; no special tools are required.

## TEST PROCEDURE

No testing of the flow Control is required prior to reassembly to the pilot control system on Cla-Val Main Valve.





### 3/8" CV Flow Control

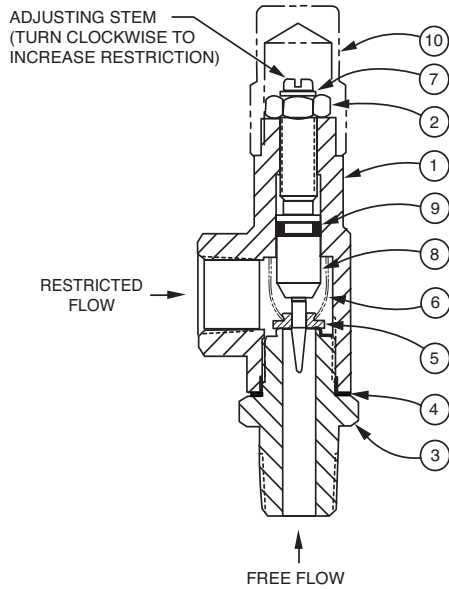

| Item No. | Description     | QTY |
|----------|-----------------|-----|
| 1        | Housing         | 1   |
| 2        | Nut, Jam        | 1   |
| 3        | Seat            | 1   |
| 4        | Gasket          | 1   |
| 5        | Disc            | 1   |
| 6        | Spring          | 1   |
| 7        | Ring, Retaining | 1   |
| 8        | Stem            | 1   |
| 9        | O-Ring          | 1   |
| 10       | Cap (SS only)   | 1   |

### 1/2", 3/4", and 1" CV Flow Control

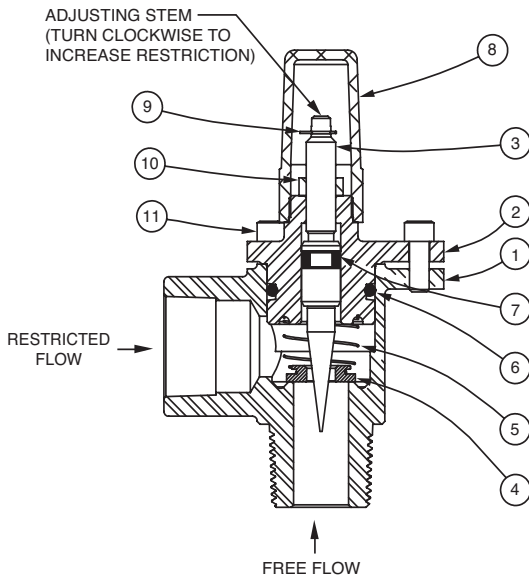

| Item No. | Description           | QTY |
|----------|-----------------------|-----|
| 1        | Body                  | 1   |
| 2        | Cover                 | 1   |
| 3        | Stem                  | 1   |
| 4        | Disc                  | 1   |
| 5        | Spring                | 1   |
| 6        | O-Ring                | 1   |
| 7        | O-Ring                | 1   |
| 8        | Cap                   | 1   |
| 9        | Ring, Retaining       | 1   |
| 10       | Nut, Jam              | 1   |
| 11       | Socket Head Cap Screw | 3   |

### When Ordering, Please Specify

1. All Nameplate/Stamped data
2. Item Number
3. Description
4. Material





# Cla-Val Product ID

## HOW TO ORDER

### PROPER IDENTIFICATION

For ordering repair kits, replacement parts, or for inquiries concerning valve operation, it is important to properly identify Cla-Val products already in service by including all nameplate data with your inquiry. Pertinent product data includes valve function, size, material, pressure rating, end details, type of pilot controls used and control adjustment ranges.

### IDENTIFICATION PLATES

For product identification, cast-in body markings are supplemented by identification plates as illustrated on this page. The plates, depending on type and size of product, are mounted in the most practical position. **It is extremely important that these identification plates are not painted over, removed, or in any other way rendered illegible.**



This brass plate appears on altitude valves only and is found on top of the outlet flange.

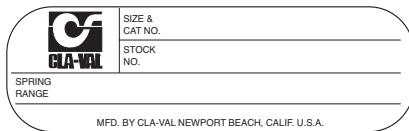

This tag is affixed to the cover of the pilot control valve. The adjustment range appears in the spring range section.

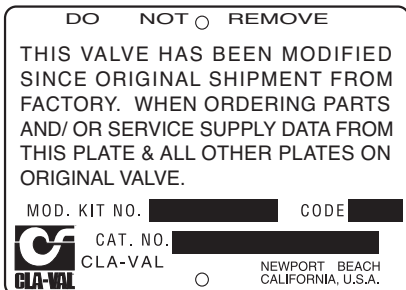

This aluminum plate is included in pilot system modification kits and is to be wired to the new pilot control system after installation.

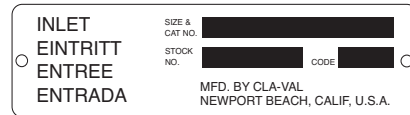

This brass plate appears on valves sized 2 1/2" and larger and is located on the top of the inlet flange.

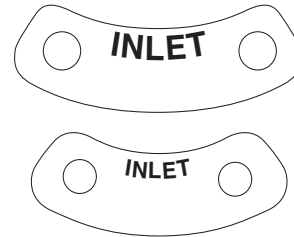

These two brass plates appear on 3/8", 1/2", and 3/4" size valves and are located on the valve cover.

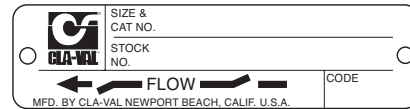

These two brass plates appear on threaded valves 1" through 3" size or flanged valves 1" through 2". It is located on only one side of the valve body.

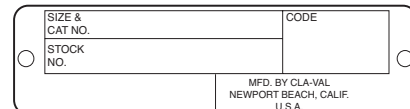

This brass plate is used to identify pilot control valves. The adjustment range is stamped into the plate.

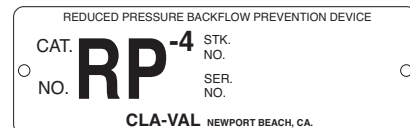

This brass plate is used on our backflow prevention assemblies. It is located on the side of the Number Two check (2" through 10"). The serial number of the assembly is also stamped on the top of the inlet flange of the Number One check.

### How to Order

Because of the vast number of possible configurations and combinations available, many valves and controls are not shown in published product and price lists. For ordering information, price and availability on product that are not listed, please contact your local Cla-Val office or our factory office located at:

P. O. Box 1325  
Newport Beach, California 92659-0325  
(949) 722-4800  
FAX (949) 548-5441



## When Ordering, Please Specify

- |                           |                                      |                        |                            |                      |
|---------------------------|--------------------------------------|------------------------|----------------------------|----------------------|
| 1. Model Number           | 3. Adjustment range (as application) | 4. Valve Size          | 6. Body and Trim Materials | 7. Optional Features |
| 2. Globe or Angle Pattern |                                      | 5. Threaded or Flanged |                            | 8. Pressure Class    |

## Unless Otherwise Specified

- Globe or angle pattern are the same price
- Ductile iron body and bronze trim are standard
- X46 Flow Clean Strainer or X43 "Y" Strainer are included
- CK2 Isolation Valves are included in price on 4" and larger valve sizes (6" and larger on 600 Series)

## Limited Warranty

Automatic valves and controls as manufactured by Cla-Val are warranted for three years from date of shipment against manufacturing defects in material and workmanship that develop in the service for which they are designed, provided the products are installed and used in accordance with all applicable instructions and limitations issued by Cla-Val. Electronic components manufactured by Cla-Val are warranted for one year from the date of shipment.

We will repair or replace defective material, free of charge, that is returned to our factory, transportation charges prepaid, if upon inspection, the material is found to have been defective at time of

original shipment. This warranty is expressly conditioned on the purchaser's providing written notification to Cla-Val immediate upon discovery of the defect.

Components used by Cla-Val but manufactured by others, are warranted only to the extent of that manufacturer's guarantee.

This warranty shall not apply if the product has been altered or repaired by others, Cla-Val shall make no allowance or credit for such repairs or alterations unless authorized in writing by Cla-Val.

## Disclaimer of Warranties and Limitations of Liability

The foregoing warranty is exclusive and in lieu of all other warranties and representations, whether expressed, implied, oral or written, including but not limited to any implied warranties or merchantability or fitness for a particular purpose. All such other warranties and representations are hereby canceled.

Cla-Val shall not be liable for any incidental or consequential loss, damage or expense arising directly or indirectly from the use of the

product. Cla-Val shall not be liable for any damages or charges for labor or expense in making repairs or adjustments to the product. Cla-Val shall not be liable for any damages or charges sustained in the adaptation or use of its engineering data and services. No representative of Cla-Val may change any of the foregoing or assume any additional liability or responsibility in connection with the product. The liability of Cla-Val is limited to material replacements F.O.B. Newport Beach, California.

## Terms of Sale

### ACCEPTANCE OF ORDERS

All orders are subject to acceptance by our main office at Newport Beach, California.

### CREDIT TERMS

Credit terms are net thirty (30) days from date of invoice.

### PURCHASE ORDER FORMS

Orders submitted on customer's own purchase order forms will be accepted only with the express understanding that no statements, clauses, or conditions contained in said order form will be binding on the Seller if they in any way modify the Seller's own terms and conditions of sales.

### PRODUCT CHANGES

The right is reserved to make changes in pattern, design or materials when deemed necessary, without prior notice.

### PRICES

All prices are F.O.B. Newport Beach, California unless expressly stated otherwise on our acknowledgment of the order. Prices are subject to change without notice. The prices at which any order is accepted are subject to adjustment to the Seller's price in effect at the time of shipment. Prices do not include sales, excise, municipal, state or any other Government taxes. Minimum order charge \$100.00.

### RESPONSIBILITY

We will not be responsible for delays resulting from strikes, accidents, negligence of carriers, or other causes beyond our control. Also, we will not be liable for any unauthorized product alterations or charges accruing there from.

### RISK

All goods are shipped at the risk of the purchaser after they have been delivered by us to the carrier. Claims for error, shortages, etc., must be made upon receipt of goods.

### EXPORT SHIPMENTS

Export shipments are subject to an additional charge for export packing.

### RETURNED GOODS

1. Customers must obtain written approval from Cla-Val prior to returning any material.
2. Cla-Val reserves the right to refuse the return of any products.
3. Products more than six (6) months old cannot be returned for credit.
4. Specially produced, non-standard models cannot be returned for credit.
5. Rubber goods such as diaphragms, discs, o-rings, etc., cannot be returned for credit, unless as part of an unopened vacuum sealed repair kit which is less than six months old.
6. Goods authorized for return are subject to a 35% (\$100 minimum) restocking charge and a service charge for inspection, reconditioning, replacement of rubber parts, retesting, repainting and repackaging as required.
7. Authorized returned goods must be packaged and shipped prepaid to Cla-Val, 1701 Placentia Avenue, Costa Mesa, California 92627.

